



***GE Healthcare***

*gehealthcare.com*

# **Technical Publication**

**Direction 5649141-8EN**

**Revision 3**

**GE Healthcare**

**Medical Diagnostic Radiography XR 6000 Pre-  
Installation Manual**

Copyright © 2021-2022 by General Electric Company, Inc. All  
Rights Reserved



This page is intentionally left blank.

# ***LEGAL NOTES***

## **TRADEMARKS**

All other products and their name brands are trademarks of their respective holders.

## **COPYRIGHTS**

All Material, Copyright © 2021-2022 by General Electric Company, Inc. All rights reserved. The material presented and contained herein may not be reproduced in any form or manner, without the written permission of General Electric Company, Inc.

This page is intentionally left blank.

# LANGUAGE POLICY

<p>PARALAJMËR- IM (SQ-AL)</p>	<p>Ky manual është i disponueshëm në disa gjuhë.</p> <ul style="list-style-type: none"> <li>Nëse një ofrues shërbimi klientësh kërkon një gjuhë të ndryshme nga ato që mundësohen në Portalin e dokumentacionit të klientit, është përgjegjësia e klientit që të ofrojë shërbime përkthimi.</li> <li>Mos u përipiqi të kryeni shërbime në pajisje, pa lexuar dhe kuptuar paraprakisht manualin e shërbimit.</li> <li>Mosrespektimi i këtij paralajmërimi mund të çojë në lëndim të ofruesit të shërbimit, operatorit ose pacientit si pasojë e goditjes elektrike, mekanike ose një rreziku tjetër.</li> </ul>
<p>تحذير (AR-SA)</p>	<p>هذا الدليل متوفر بعدة لغات</p> <ul style="list-style-type: none"> <li>إذا كان مقدم الخدمة التابع للعميل يطلب لغة غير تلك المتوفرة في بوابة توثيق العميل، فإنه يقع على عاتق العميل مسؤولية تقديم خدمات الترجمة</li> <li>لا تحاول صيانة الجهاز ما لم تتم استشارة دليل الخدمة هذا وفهمه</li> <li>قد يؤدي عدم مراعاة هذا التحذير إلى إصابة مقدم الخدمة أو المشغل أو المريض من جراء الصدمات الكهربائية أو المخاطر الميكانيكية أو غيرها من المخاطر</li> </ul>
<p>ПРЕДУПРЕЖДЕНИЕ (BG)</p>	<p>Това ръководство е налично на няколко езика.</p> <ul style="list-style-type: none"> <li>Ако доставчикът на услуги на даден клиент изисква език, който е различен от осигурените в портала с документация за клиенти, отговорност на клиента е да предостави преводачески услуги.</li> <li>Не се опитвайте да обслужвате оборудването, освен ако не сте се консултирали с това сервизно ръководство и сте го разбрали.</li> <li>Несъблюдаването на това предупреждение може да доведе до нараняване на предоставящия услугите, оператора или пациента вследствие на токов удар, механична или други опасности.</li> </ul>
<p>警告 (ZH-CN)</p>	<p>本手册有多种语言版本。</p> <ul style="list-style-type: none"> <li>如果客户的服务提供商要求使用 Customer Documentation Portal (客户文档门户) 未提供的其他语言，则客户有责任提供相应的翻译服务。</li> <li>请勿尝试检修设备，除非已明确参考并理解本检修手册。</li> <li>不遵循此警告可能会导致检修服务提供者、操作员或患者受到触电、机械或其他危害的损伤。</li> </ul>
<p>警告 (ZH-HK)</p>	<p>本手冊備有多個語言版本。</p> <ul style="list-style-type: none"> <li>若客戶的服務提供者所需語言版本不在 Customer Documentation Portal (客戶文件入口網站) 所列語言之中，客戶需自行負責提供翻譯服務。</li> <li>除非已查閱並理解本檢修手冊，否則，請勿嘗試檢修設備。</li> <li>不遵循此警告可能會導致服務提供者、操作員或患者因為觸電、機械或其他危險而受傷。</li> </ul>

<p><b>警告</b> (ZH-TW)</p>	<p>本手冊備有多個語言版本。</p> <ul style="list-style-type: none"> <li>• 若客戶的服務提供者所需語言版本不在 Customer Documentation Portal ( 客戶文件入口網站 ) 所列語言之中，客戶需自行負責提供翻譯服務。</li> <li>• 除非已查閱並理解本檢修手冊，否則，請勿嘗試檢修設備。</li> <li>• 不遵循此警告可能會導致服務提供者、操作員或患者因為觸電、機械或其他危險而受傷。</li> </ul>
<p><b>UPOZORENJE</b> (HR)</p>	<p>Ovaj je priručnik dostupan na nekoliko jezika.</p> <ul style="list-style-type: none"> <li>• Ako serviser klijenta zahtijeva jezik koji nije jedan od jezika dostupnih na portalu s korisničkom dokumentacijom (Customer Documentation Portal), odgovornost je klijenta pružiti uslugu prevođenja.</li> <li>• Nemojte pokušavati servisirati opremu ako niste proučili i razumjeli ovaj servisni priručnik.</li> <li>• Nepoštovanje ovog upozorenja može izazvati ozljede servisera, rukovatelja ili pacijenta kao posljedicu strujnog udara, mehaničkih ili drugih opasnosti.</li> </ul>
<p><b>VÝSTRAHA</b> (CS)</p>	<p>Tato příručka je k dispozici v několika jazycích.</p> <ul style="list-style-type: none"> <li>• Pokud zákazníkův poskytovatel služeb vyžaduje jiný jazyk než jazyky, které jsou k dispozici na portálu s uživatelskou dokumentací, je odpovědností zákazníka poskytnout překladatelské služby.</li> <li>• Nepokoušejte se provádět servis zařízení, aniž byste prostudovali tuto servisní příručku a porozuměli jí.</li> <li>• Nedodržení tohoto varování může vést ke zranění poskytovatele služeb, obsluhy nebo pacienta, způsobenému úrazem elektrickým proudem či mechanickým nebo jiným nebezpečím.</li> </ul>
<p><b>ADVARSEL</b> (DA)</p>	<p>Denne vejledning fås på flere sprog.</p> <ul style="list-style-type: none"> <li>• Hvis en kundes tjenesteudbyder kræver et andet sprog end dem, der er til rådighed i Kundedokumentationsportalen, er det kundens ansvar at levere oversættelsestjenester.</li> <li>• Undgå at forsøge at udføre service på udstyret, medmindre du har læst og forstået denne servicevejledning.</li> <li>• Hvis du undlader at overholde denne advarsel, kan det føre til skader på servicemedarbejderen, operatøren eller patienten på grund af elektrisk stød, mekaniske eller andre farer.</li> </ul>
<p><b>WAARSCHUWING</b> (NL)</p>	<p>Deze handleiding is in verschillende talen beschikbaar.</p> <ul style="list-style-type: none"> <li>• Als de serviceprovider van een klant een andere taal vereist dan de talen die beschikbaar worden gesteld in het Customer Documentation Portal (Klantdocumentatieportaal), is het de verantwoordelijkheid van de klant om vertaalservices te leveren.</li> <li>• Probeer geen service op de apparatuur uit te voeren zonder de servicehandleiding te hebben gelezen en begrepen.</li> <li>• Het negeren van deze waarschuwing kan leiden tot letsel bij de serviceprovider, de operator of de patiënt door elektrische schokken, mechanische of andere gevaren.</li> </ul>
<p><b>WARNING</b> (EN)</p>	<p>This manual is available in several languages.</p> <ul style="list-style-type: none"> <li>• If a customer's service provider requires a language other than those provided in the Customer Documentation Portal, it is the customer's responsibility to provide translation services.</li> <li>• Do not attempt to service the equipment unless this service manual has been consulted and is understood.</li> <li>• Failure to heed this warning may result in injury to the service provider, operator or patient from electric shock, mechanical or other hazards.</li> </ul>

HOIATUS (ET)	<p>Käesolev juhend on saadaval mitmes keeles.</p> <ul style="list-style-type: none"> <li>• Kui kliendi teenusepakkuja vajab juhendit mõnes muus keeles, mida pole kliendidokumentatsiooni portaalis, on kliendi kohustuseks tõlketeenuste osutamine.</li> <li>• Ärge hakake seda seadet hooldama enne, kui olete käesolevat hooldusjuhendit lugenud ja selle siisu mõistnud.</li> <li>• Selle hoiatuse eiramine võib põhjustada hooldusteenuse pakkujale, operaatorile või patsiendile elektrilöögist, mehhaanilistest või muudest ohtudest tulenevaid vigastusi.</li> </ul>
VAROITUS (FI)	<p>Käesolev juhend on saadaval mitmes keeles.</p> <ul style="list-style-type: none"> <li>• Kui kliendi teenusepakkuja vajab juhendit mõnes muus keeles, mida pole kliendidokumentatsiooni portaalis, on kliendi kohustuseks tõlketeenuste osutamine.</li> <li>• Ärge hakake seda seadet hooldama enne, kui olete käesolevat hooldusjuhendit lugenud ja selle siisu mõistnud.</li> <li>• Selle hoiatuse eiramine võib põhjustada hooldusteenuse pakkujale, operaatorile või patsiendile elektrilöögist, mehhaanilistest või muudest ohtudest tulenevaid vigastusi.</li> </ul>
ATTENTION (FR)	<p>Ce manuel est disponible en plusieurs langues.</p> <ul style="list-style-type: none"> <li>• Si le prestataire de services d'un client nécessite que le manuel soit rédigé dans une autre langue que celles fournies sur le Portail de Documentation Client, il incombe au client de le faire traduire.</li> <li>• Ne pas essayer d'assurer la maintenance de l'équipement sans avoir au préalable consulté et compris les informations contenues dans ce manuel.</li> <li>• Le non-respect de cet avertissement peut entraîner chez le technicien, l'opérateur ou le patient des blessures dues à des dangers électriques, mécaniques ou autres.</li> </ul>
WARNUNG (DE)	<p>Dieses Handbuch ist in mehreren Sprachen erhältlich.</p> <ul style="list-style-type: none"> <li>• Wenn ein Dienstleister des Kunden dieses in einer anderen Sprache als der im Kundendokumentationsportal verfügbaren benötigt, liegt es in der Verantwortung des Kunden, Übersetzungsdienstleistungen zu erbringen.</li> <li>• Wartungsarbeiten am Gerät dürfen nur durchgeführt werden, nachdem dieses Wartungshandbuch gelesen und verstanden wurde.</li> <li>• Andernfalls besteht Verletzungsgefahr für den Dienstleister, Bediener oder Patienten durch Stromschlag, mechanische Gefahren oder andere Gefahren.</li> </ul>
ΠΡΟΕΙΔΟΠΟΙΗΣΗ (EL)	<p>Αυτό το εγχειρίδιο διατίθεται σε διάφορες γλώσσες.</p> <ul style="list-style-type: none"> <li>• Εάν ο πάροχος υπηρεσιών συντήρησης ενός πελάτη χρειάζεται διαφορετική γλώσσα από αυτές που διατίθενται στο Customer Documentation Portal (Πύλη τεκμηριώσεων πελάτη), ο πελάτης είναι υπεύθυνος για την παροχή υπηρεσιών μετάφρασης.</li> <li>• Μην επιχειρήσετε να εκτελέσετε συντήρηση του εξοπλισμού, εάν δεν έχετε διαβάσει και κατανοήσει το παρόν εγχειρίδιο συντήρησης.</li> <li>• Εάν δεν τηρήσετε αυτήν την προειδοποίηση, μπορεί να προκληθεί τραυματισμός του παρόχου υπηρεσιών συντήρησης, του χειριστή ή του ασθενούς λόγω ηλεκτροπληξίας, μηχανικής βλάβης ή άλλου κινδύνου.</li> </ul>
אזהרה (HE)	<p>מדריך זה זמין במספר שפות</p> <ul style="list-style-type: none"> <li>• פורטל תיעוד -Customer Documentation Portal אם ספק שירות של לקוח זקוק לשפה שאינה מסופקת בללקוחות), באחריות הלקוח לספק את שירותי התרגום</li> <li>• אסור לנסות להעניק שירות לציוד לפני עיון במדריך שירות זה והבנת התוכן שלו</li> <li>• פעולה שלא בהתאם לאזהרה זו עלולה לגרום לפציעה של ספק השירות, המפעיל או המטופל כתוצאה מהתחשמלות, סיכונים מכניים או סיכונים אחרים</li> </ul>

<p>FIGYELMEZ- TETÉS (HU)</p>	<p>Ez a kézikönyv több nyelven is rendelkezésre áll.</p> <ul style="list-style-type: none"> <li>• Ha az ügyfél szervizszolgáltatója azoktól eltérő nyelvű kézikönyvet szeretne, mint amelyeket az Ügyféldokumentációs portálon biztosítunk, akkor az ügyfél feladata, hogy gondoskodjon a megfelelő fordításról.</li> <li>• Ne próbálkozzon a berendezés szervizelésével anélkül, hogy a jelen szervizkézikönyvet elolvasta és megértette volna.</li> <li>• Ennek a figyelmeztetésnek a figyelmen kívül hagyása áramütés, mechanikai vagy egyéb veszélyek következtében a szervizszolgáltató, a kezelő vagy a páciens sérülését okozhatja.</li> </ul>
<p>ADVÖRUN (IS)</p>	<p>Þessi handbók er fánleg á mörgum tungumálum.</p> <ul style="list-style-type: none"> <li>• Ef þjónustuaðili viðskiptavinar þarfnast annars tungumáls en þessara tungumála er það á ábyrgð viðskiptavinarins að veita þýðingarþjónustu.</li> <li>• Ekki reyna að þjónusta búnaðinn fyrr en búið er að lesa og skilja þessa þjónustuhandbók.</li> <li>• Sé ekki farið eftir þessari viðvörðun getur það valdið meiðslum á þjónustuaðila, notanda eða sjúklingi af völdum raflösts, vélrænna áverka eða annarar hættu.</li> </ul>
<p>PERINGATAN (IN)</p>	<p>Manual ini tersedia dalam beberapa bahasa.</p> <ul style="list-style-type: none"> <li>• Jika penyedia layanan pelanggan membutuhkan bahasa selain dari yang disediakan dalam Portal Dokumentasi Pelanggan, merupakan tanggung jawab pelanggan untuk menyediakan layanan penerjemahan.</li> <li>• Jangan berupaya untuk melakukan servis pada peralatan sebelum menyimak manual servis dan memahami isinya.</li> <li>• Jika peringatan ini tidak ditaati, ini dapat menyebabkan cedera penyedia layanan, operator, atau pasien, akibat sengatan listrik, bahaya mekanis, atau bahaya lainnya.</li> </ul>
<p>AVVERTENZA (IT)</p>	<p>Il presente manuale è disponibile in varie lingue.</p> <ul style="list-style-type: none"> <li>• Qualora un fornitore di servizi del cliente richieda una lingua diversa da quelle fornite nel Portale con la documentazione per il cliente, sarà responsabilità del cliente fornire il servizio di traduzione corrispondente.</li> <li>• Non tentare di riparare l'apparecchiatura se non si è prima consultato e compreso il presente manuale di servizio.</li> <li>• Il mancato rispetto di questa avvertenza può provocare lesioni per il fornitore dei servizi, per l'operatore o per il paziente, a causa di scosse elettriche, meccaniche o altri pericoli.</li> </ul>
<p>警告 (JA)</p>	<p>本マニュアルは多言語で提供されています。</p> <ul style="list-style-type: none"> <li>• お客様のサービスプロバイダが、お客様ドキュメントポータルページで使用されていない言語を必要とする場合は、お客様の責任で翻訳サービスを提供してください。</li> <li>• 機器の保守を行う場合は、必ず本サービスマニュアルを読み理解した上で行ってください。</li> <li>• この警告に従わない場合は、サービスプロバイダー、オペレータ、または患者が、感電、機械的異常、またはその他の有害要因によって負傷する恐れがあります。</li> </ul>
<p>경고 (KO)</p>	<p>이 설명서는 여러 언어로 제공됩니다.</p> <ul style="list-style-type: none"> <li>• 고객의 서비스 제공자가 고객 문서 포털에 제공된 언어가 아닌 다른 언어를 요구하는 경우 번역 서비스를 제공하는 것은 고객의 책임입니다.</li> <li>• 이 서비스 설명서를 참고했고 이해하지 않는 한은 해당 장비를 수리하려고 시도하지 마십시오.</li> <li>• 이 경고를 지키지 않으면 감전, 기계상의 위험 또는 다른 위험으로부터 서비스 제공자, 사용자 또는 환자가 다칠 수 있습니다.</li> </ul>

BRĪDINĀJUMS (LV)	<p>Šī rokasgrāmata ir pieejama vairākās valodās.</p> <ul style="list-style-type: none"> <li>• Ja klientu apkalpošanas speciālistam ir nepieciešama cita valoda, kas nav piedāvāta klientu dokumentācijas portālā, klienta pienākums ir nodrošināt tulkošanas pakalpojumus.</li> <li>• Nemēģiniet veikt aprikojuma apkopi, kamēr nav izlasīta un izprasta apkopes rokasgrāmata.</li> <li>• Ja šis brīdinājums netiek ņemts vērā, pakalpojumu sniedzējs, operators vai pacients var tikt savainots elektriskās strāvas trieciena, mehāniskas vai citas bīstamības rezultātā.</li> </ul>
ĪSPĒJIMAS (LT)	<p>Šis vadovas yra išverstas į keletą kalbų.</p> <ul style="list-style-type: none"> <li>• Jei kliento paslaugų teikėjui reikalingas vertimas į kitą kalbą, kurios nėra kliento dokumentacijos portale, už vertimo paslaugų suteikimą atsako klientas.</li> <li>• Neatlikite įrangos techninės priežiūros, kol neperžiūrėjote ir neišsiaiškinote šio techninės priežiūros vadovo.</li> <li>• Nepaisant šio įspėjimo dėl elektros smūgio, mechaninio arba kitokio pavojaus gali būti sužalotas paslaugų teikėjas, operatorius arba pacientas.</li> </ul>
TWISSIJA (MT)	<p>Dan il-manwal huwa disponibbli f'diversi lingwi.</p> <ul style="list-style-type: none"> <li>• Jekk fornitur tas-servizz ta' klient ikun jeħtieg lingwa għajr daww ipprovduti fil-Portal tad-Dokumentazzjoni tal-Klijent, hija r-responsabbiltà tal-klijent li jipprovidi servizzi ta' traduzzjoni.</li> <li>• Tippruvax tagħmel service fuq it-tagħmir sakemm ma jkunx għie kkonsultat u mifhum dan il-manwal għas-service.</li> <li>• Jekk wieħed jonqos milli josserva din it-twissija, dan jista' jwassal f'korriment lill-fornitur tas-servizz, lill-operatur jew lill-pazjent minn xokk elettriku, mekkaniku, jew perikli oħra.</li> </ul>
ADVARSEL (NO)	<p>Denne håndboken er tilgjengelig på flere språk.</p> <ul style="list-style-type: none"> <li>• Hvis en kundes tjenesteleverandør krever et annet språk enn de som finnes i dokumentasjonsportalen for kunder, er det kundens ansvar å levere en oversettelsestjeneste.</li> <li>• Ikke prøv å utfør service på utstyret med mindre man har konsultert og forstått servicehåndboken.</li> <li>• Om denne advarselen ikke følges kan det føre til skade på tjenesteleverandør, operatør eller pasient fra elektrisk støt, mekanisk eller annen fare.</li> </ul>
OSTRZEŻENIE (PL)	<p>Niniejszy podręcznik jest dostępny w kilku językach.</p> <ul style="list-style-type: none"> <li>• Jeżeli serwisant klienta wymaga języka, który nie został udostępniony w portalu dokumentacji klienta, obowiązkiem klienta jest zapewnienie usług tłumaczeniowych.</li> <li>• Nie podejmować prób serwisowania urządzenia bez uprzedniego zapoznania się z niniejszym podręcznikiem serwisowym i zrozumienia jego treści.</li> <li>• Nieprzestrzeżenie tego ostrzeżenia może spowodować obrażenia u serwisanta, operatora lub pacjenta, spowodowane porażeniem prądem, zagrożeniami mechanicznymi lub innymi.</li> </ul>
ATENÇÃO (PT-BR)	<p>Este manual está disponível em vários idiomas.</p> <ul style="list-style-type: none"> <li>• Se o prestador de serviços de um cliente necessitar de um idioma diferente dos fornecidos no Portal da Documentação do Cliente, o fornecimento dos serviços de tradução é de responsabilidade do cliente.</li> <li>• Não tente realizar manutenção do equipamento a menos que o manual de serviço tenha sido consultado e seja entendido.</li> <li>• O não cumprimento deste aviso resultará em lesões ao provedor de serviço, operador ou paciente de choque elétrico, mecânico ou outros riscos.</li> </ul>

ATENÇÃO (PT-PT)	<p>Este manual está disponível em vários idiomas.</p> <ul style="list-style-type: none"><li>• Se o fornecedor de serviços de um cliente necessitar de um idioma diferente dos fornecidos no Portal de Documentação do Cliente, é da responsabilidade do cliente assegurar os serviços de tradução.</li><li>• Não experimente reparar o equipamento sem primeiro consultar, e compreender, o presente manual de assistência.</li><li>• O incumprimento deste aviso pode resultar em ferimentos para o técnico de reparação, o operador ou o paciente decorrentes de perigos de eletrocussão, mecânicos ou outros.</li></ul>
ATENȚIE (RO)	<p>Acest manual este disponibil în mai multe limbi.</p> <ul style="list-style-type: none"><li>• Dacă furnizorul de servicii al unui client necesită o limbă diferită de cele furnizate în Customer Documentation Portal (Portalul cu documentație pentru clienți), este responsabilitatea clientului să furnizeze servicii de traducere.</li><li>• Nu încercați să efectuați întreținerea echipamentului decât dacă ați consultat și ați înțeles acest manual de service.</li><li>• Nerespectarea acestei avertizări poate duce la rănirea furnizorului de servicii, a operatorului sau a pacientului din cauza șocurilor electrice, mecanice sau a altor pericole.</li></ul>
ПРЕДУПРЕЖДЕНИЕ (RU)	<p>Это руководство доступно на нескольких языках.</p> <ul style="list-style-type: none"><li>• Если поставщику услуг заказчика требуется языковая версия, отличная от предложенных на портале документации для заказчиков, перевод руководства на необходимый язык осуществляется стороной заказчика.</li><li>• Не начинайте эксплуатацию оборудования без предварительного надлежащего ознакомления с этим руководством.</li><li>• Если вы проигнорируете это предупреждение, поставщик услуг, оператор или пациент могут получить механические травмы, травмы вследствие поражения электрическим током или другие увечья.</li></ul>
UPOZORENJE (SR)	<p>Ovaj priručnik je dostupan na nekoliko jezika.</p> <ul style="list-style-type: none"><li>• Ako korisnikov serviser zahteva neki drugi jezik osim onih koji su dostupni na portalu sa korisničkom dokumentacijom (Customer Documentation Portal), klijent mora da obezbedi prevod.</li><li>• Nemojte pokušavati da servisirate opremu ako niste proučili i razumeli ovaj priručnik za servisiranje.</li><li>• Nepoštovanje ovog upozorenja može da izazove povrede serviseru, operatera ili pacijenta kao posledicu strujnog udara, mehaničkih ili drugih opasnosti.</li></ul>
UPOZORNENIE (SK)	<p>Táto príručka je k dispozícii v niekoľkých jazykoch.</p> <ul style="list-style-type: none"><li>• Ak poskytovateľ služieb daného zákazníka požaduje jazyk odlišný od jazykov dostupných na portáli s dokumentáciou pre zákazníkov, za prekladateľské služby zodpovedá zákazník.</li><li>• Nepokúšajte sa vykonávať servis na zariadení, pokiaľ ste si neprečítali a nepochopili pokyny v servisnej príručke.</li><li>• Nedodržanie tohto varovania môže byť príčinou úrazu poskytovateľa servisu, obsluhy alebo pacienta v dôsledku zásahu elektrickým prúdom alebo v dôsledku mechanických alebo iných nebezpečenstiev.</li></ul>

<p>OPOZORILO (SL)</p>	<p>Ta priročnik je na voljo v več jezikih.</p> <ul style="list-style-type: none"> <li>• Če ponudnik storitev stranke potrebuje priročnik v jeziku, ki ni na voljo na portalu z dokumentacijo stranke, mora stranka zagotoviti prevod.</li> <li>• Opreme ne poskušajte servisirati, če niste prebrali in razumeli tega servisnega priročnika.</li> <li>• V primeru neupoštevanja tega opozorila lahko pride do telesnih poškodb ponudnika storitev, upravljavca ali pacienta zaradi električnega udara, mehanskih ali drugih nevarnosti.</li> </ul>
<p>ADVERTENCIA (ES)</p>	<p>Este manual se encuentra disponible en varios idiomas.</p> <ul style="list-style-type: none"> <li>• Si el proveedor de servicios de un cliente requiere un idioma distinto de los proporcionados en el Customer Documentation Portal (Portal de documentación para clientes), es responsabilidad del cliente proporcionar los servicios de traducción.</li> <li>• No intente realizar el mantenimiento del sistema a menos que haya consultado y comprendido este manual de servicio.</li> <li>• El incumplimiento de esta advertencia puede causar lesiones al suministrador de servicios, el operador o el paciente debido a descarga eléctrica, mecánica u otros riesgos.</li> </ul>
<p>VARNING (SV)</p>	<p>Denna manual är tillgänglig på flera språk.</p> <ul style="list-style-type: none"> <li>• Om en kunds tjänsteleverantör behöver ett annat språk än de som tillgängliggjorts på portalen för kunddokumentation är det kundens ansvar att erbjuda översättningstjänster.</li> <li>• Försök inte att reparera utrustningen utan att först rådfråga och förstå denna servicehandbok.</li> <li>• Om denna varning inte beaktas kan det leda till skada för tjänsteleverantör, operatör eller patient genom elektrisk stöt, mekaniska eller andra faror.</li> </ul>
<p>DİKKAT (TR)</p>	<p>Bu kılavuz birden fazla dilde sunulmaktadır.</p> <ul style="list-style-type: none"> <li>• Bir müşterinin servis sağlayıcısı Müşteri Belgeleri Portalı'nda sağlananlardan farklı bir dil talep ederse çeviri hizmeti müşterinin sorumluluğundadır.</li> <li>• Bu servis kılavuzuna başvurmadan ve içeriğini anlamadan ekipman üzerinde servis işlemi yapmayı denemeyin.</li> <li>• Bu uyarıya uyulmaması; elektrik çarpması, mekanik tehlikeler veya başka tehlikelerden ötürü servis sağlayıcı, operatör veya hastanın yaralanmasıyla sonuçlanabilir.</li> </ul>
<p>ПОПЕРЕДЖЕННЯ (UK)</p>	<p>Цей посібник доступний кількома мовами.</p> <ul style="list-style-type: none"> <li>• Якщо постачальник послуг замовника використовує мову, яку не вказано на порталі з документацією для замовників, послуги з перекладу має забезпечити замовник.</li> <li>• Не починайте роботу з обладнанням без попереднього належного ознайомлення з посібником із використання.</li> <li>• Якщо ви проігноруєте це попередження, постачальник послуг, оператор або пацієнт можуть зазнати механічних травм, ураження електричним струмом або інших тілесних ушкоджень.</li> </ul>
<p>CẢNH BÁO (VI)</p>	<p>Tài liệu hướng dẫn này có sẵn ở một số ngôn ngữ.</p> <ul style="list-style-type: none"> <li>• Nếu nhà cung cấp dịch vụ của khách hàng yêu cầu ngôn ngữ khác với ngôn ngữ được cung cấp trong Cổng Thông Tin Tài Liệu Khách Hàng, khách hàng có trách nhiệm cung cấp dịch vụ dịch thuật.</li> <li>• Không cố bảo dưỡng thiết bị trừ khi đã tham khảo và hiểu rõ hướng dẫn sử dụng này.</li> <li>• Việc không chú ý đến cảnh báo này có thể dẫn đến thương tích cho nhà cung cấp dịch vụ, người vận hành hoặc bệnh nhân do điện giật, nguy hiểm cơ học hoặc các mối nguy hiểm khác.</li> </ul>

## DAMAGE IN TRANSPORTATION

All packages should be closely examined at time of delivery. If damage is apparent write "Damage In Shipment" on ALL copies of the freight or express bill BEFORE delivery is accepted or "signed for" by a GE representative or hospital receiving agent. Whether noted or concealed, damage MUST be reported to the carrier immediately upon discovery, or in any event, within 14 days after receipt, and the contents and containers held for inspection by the carrier. A transportation company will not pay a claim for damage if an inspection is not requested within this 14 day period. Call GEHC Global Parts 1-800-548-3366 and select option 8, immediately after damage is found. At this time be ready to supply name of carrier, delivery date, consignee name, freight or express bill number, item damaged and extent of damage.

Complete instructions regarding claim procedure are found in Section S of the Policy And Procedures Bulletins.

14 July 1993

## CERTIFIED ELECTRICAL CONTRACTOR STATEMENT

All electrical Installations that are preliminary to positioning of the equipment at the site prepared for the equipment shall be performed by licensed electrical contractors. In addition, electrical feeds into the Power Distribution Unit shall be performed by licensed electrical contractors. Other connections between pieces of electrical equipment, calibrations and testing shall be performed by qualified GE Healthcare personnel. The products involved (and the accompanying electrical installations) are highly sophisticated, and special engineering competence is required. In performing all electrical work on these products, GE will use its own specially trained field engineers. All of GE's electrical work on these products will comply with the requirements of the applicable electrical codes.

The purchaser of GE equipment shall only utilize qualified personnel (i.e., GE's field engineers, personnel of third-party service companies with equivalent training, or licensed electricians) to perform electrical servicing on the equipment.

## IMPORTANT...X-RAY PROTECTION

X-ray equipment, if not properly used, may cause injury. Accordingly, the instructions herein contained should be thoroughly read and understood by everyone who will use the equipment before you attempt to place this equipment in operation. The General Electric Company, Healthcare Group, will be glad to assist and cooperate in placing this equipment in use.

Although this apparatus incorporates a high degree of protection against x-radiation other than the useful beam, no practical design of equipment can provide complete protection. Nor can any practical design compel the operator to take adequate precautions to prevent the possibility of any persons carelessly exposing themselves or others to radiation.

It is important that anyone having anything to do with x-radiation be properly trained and fully acquainted with the recommendations of the National Council on Radiation Protection and Measurements as published in NCRP Reports available from NCRP Publications, 7910 Woodmont Avenue, Room 1016, Bethesda, Maryland 20814, and of the International Commission on Radiation Protection, and of any other local authorities, and take adequate steps to protect against

injury.

The equipment is sold with the understanding that the General Electric Company, Healthcare Group, its agents, and representatives have no responsibility for injury or damage which may result from improper use of the equipment.

Various protective materials and devices are available. It is urged that such materials or devices be used.

## **OMISSIONS & ERRORS**

Customers, please contact your GE Sales or Service representatives.

GE personnel, please use the GEHC Complaint Record Process to report all omissions, errors, and defects in this publication.

This page is intentionally left blank.

# Table of Contents

LEGAL NOTES.....	3
LANGUAGE POLICY.....	5
DAMAGE IN TRANSPORTATION.....	12
CERTIFIED ELECTRICAL CONTRACTOR STATEMENT.....	12
IMPORTANT...X-RAY PROTECTION.....	12
OMISSIONS & ERRORS.....	13
Table of Contents.....	15
Chapter 1 - Introduction.....	17
Section 1.0 Objective and Scope of this Manual.....	17
Section 2.0 Avoiding Unnecessary Expenses and Delays.....	17
Section 3.0 An Overview of the Pre-Installation Process.....	17
Section 4.0 Responsibility of Purchaser/Customer.....	18
Section 5.0 Contract Changes.....	18
Section 6.0 Responsibilities of the Purchaser.....	19
Section 7.0 What You Will Receive (System Components).....	19
Chapter 2 - Room Requirements.....	23
Section 1.0 Environmental Requirements.....	23
1.1 Relative Humidity and Temperature.....	23
1.2 Altitude and Atmospheric Pressure.....	24
1.3 Heat Output.....	24
1.4 Acoustic Output.....	26
1.5 Radiation Protection.....	26
Section 2.0 Structural Requirements.....	26
2.1 Door Size Requirements.....	26
2.2 Floor Requirements.....	26
Chapter 3 - Planning Electrical Connections.....	33
Section 1.0 Routing Cables.....	33
1.1 General.....	33
1.2 Conduit.....	33
1.3 Electrical Ducts.....	33
1.4 Power Distribution.....	36
Section 2.0 Master Interconnect System (MIS).....	36
Chapter 4 - System Facility Power & Grounds.....	37
Section 1.0 Introduction.....	37
1.1 Power Quality.....	37
1.2 Electrical Requirements.....	38
Section 2.0 Electrical Grounds.....	44
2.1 System and Facility Grounds.....	44
2.2 Recommended Ground Wire Sizes.....	44
2.3 Final Checks, Before System Installation Can Begin.....	44
Chapter 5 - Product Characteristics.....	47
Section 1.0 Overview.....	47
Section 2.0 System Components Dimensions and Weights.....	47
2.1 Dimensions.....	47
2.2 Dimensioned Figures and Drawings.....	48
Section 3.0 Positioning and Mounting Equipment.....	60

3.1	Floor Loading and Recommended Mounting Methods .....	60
Chapter 6 -	Room Layout .....	61
Section 1.0	Radiation Production.....	61
Section 2.0	Clinical Access.....	61
Section 3.0	Peripheral Equipment.....	61
Section 4.0	Room Layout Drawings.....	62
Section 5.0	Room layout with degraded function.....	63
5.1	Room layout without tube arm 180 degree rotation function .....	63
5.2	Room layout with tube arm 180 degree rotation function .....	64
Chapter 7 -	Planning Aids .....	65
Section 1.0	Shipping Dimensions and Weights .....	65
Section 2.0	Installation Tools and Materials Required .....	66
2.1	Tools and Materials Checklist .....	66
Section 3.0	Preparing the Delivery Route .....	67
Section 4.0	Pre-Installation Checklist .....	68
Chapter 8 -	System Cable Information .....	71
Section 1.0	Introduction.....	71
Section 2.0	Cable Information.....	72
2.1	Cable Lengths and Characteristics .....	72
Appendix A -	Electromagnetic Compatibility (EMC) .....	75
Section 1.0	Compliance Statement .....	75
Section 2.0	Compatibility Tables .....	76
2.1	Electromagnetic Emission.....	76
2.2	Electromagnetic Immunity .....	77
Section 3.0	Use Recommendations .....	79
Section 4.0	Installation Recommendations.....	80
4.1	Cable Shielding & Grounding.....	80
4.2	Subsystem & Accessories Power Supply Distribution .....	80
4.3	Stacked Components & Equipment .....	80
4.4	Low Frequency Magnetic Field .....	80
4.5	Electrostatic Discharge Environment & Recommendations.....	80
Appendix B -	Revision History .....	81

# ***Chapter 1 - Introduction***

## **Section 1.0 Objective and Scope of this Manual**

This document is intended as a guide and informational resource for planning and properly preparing a location for the installation of a system.

## **Section 2.0 Avoiding Unnecessary Expenses and Delays**

To avoid unnecessary expenses and delays, use the “Pre-Installation” checklist located in [Chapter 7](#) to determine if you are ready for the installation to begin. Once you believe that your room/location is ready for installation to begin, complete the “Pre-Installation” checklist. The checklist is an important tool that helps verify that nothing has been missed. The checklist summarizes the preparations and allows you to record a permanent record of the activities that have taken place.

## **Section 3.0 An Overview of the Pre-Installation Process**

Pre-installation is a co-operative effort between the customer/purchaser and GE Healthcare (GEHC). Complete the checklists contained in this manual. They are an important part of the pre-installation process. The checklists summarize the required preparations and verify the completion of the pre-installation procedures.

[Figure 1-1](#) outlines the information in this document and its place in the pre-installation process.

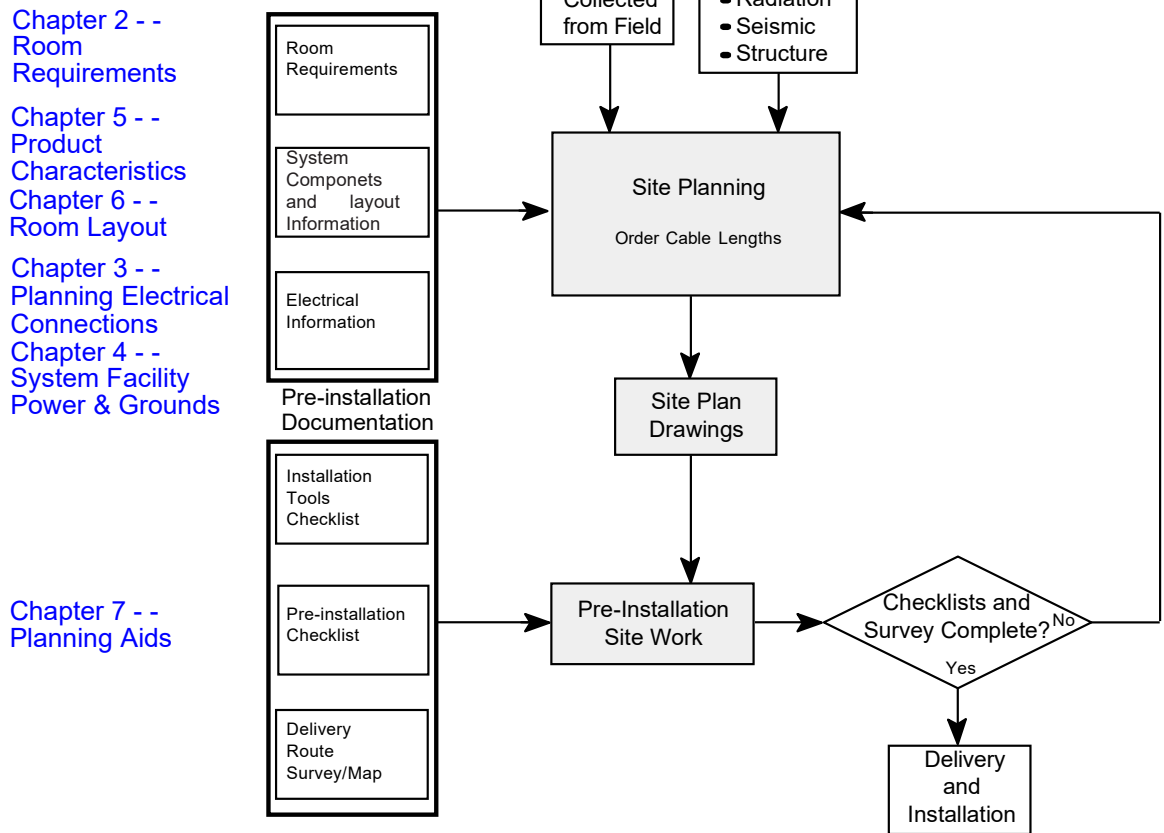

Figure 1-1 Pre-Installation Overtable

## Section 4.0 Responsibility of Purchaser/Customer

To ensure that the installation of the system meets the purchaser or Customer expectations, it is important to determine who will take responsibility for various items in the course of the system installation process. To aid you in determining these responsibilities, review the following checklists with the customer and assign responsibilities as appropriate:

- Tools and Equipment Checklist (see [Chapter 7-2.1 Tools and Materials Checklist](#))
- Pre-Installation Checklist (see [Chapter 7-Section 4.0Pre-Installation Checklist](#))

## Section 5.0 Contract Changes

Be sure to inform the customer that the cost of any alterations or modifications not specified in the sales contract are the responsibility of the customer.

## Section 6.0 Responsibilities of the Purchaser

The purchaser is responsible for completion of “Pre-Installation”. This includes the procurement and installation of all required materials and services to get the room ready for installation of the product. This responsibility includes providing:

- A clean and safe work environment for installation of the product (finished floor, ceiling, walls, and proper room lighting).
- A location suitable for the installation of the product. See [Chapter 2 - - Room Requirements](#).
  - Suitable support structures in the floor, walls, or ceiling necessary for the mounting of the product and/or its components.
  - Installation of conduit, ducts and/or raceways necessary to route cables safely. See [Chapter 4 - - System Facility Power & Grounds](#) and [Chapter 5 - - Product Characteristics](#)
  - Electrical power and grounds of specified quality and reliability. See [Chapter 4 - - System Facility Power & Grounds](#).
    - \* Electrical power of the required voltage, including an emergency-off safety switch in the room. Power and ground cables to the PDU.
    - \* Properly installed and sized junction boxes, including covers and fittings at locations required and called out in architectural drawings.
- A location suitable for operation of the product. See [Chapter 6 - - Room Layout](#).
- Installation of non-electric services.

## Section 7.0 What You Will Receive (System Components)

The system may consist of the following main components (See [Figure 1-2](#) and [Table 1-1](#)):

- Table - Standard/Basic
- Wall Stand - Standard/Basic
- Control room collector
- Generator
- PDU
- X-Ray Tube - 32KW/50KW
- Collimator - XS-1A/GE



1

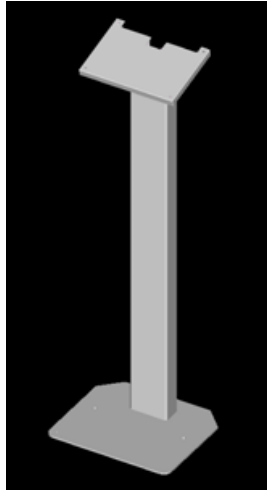

2



3/4/5

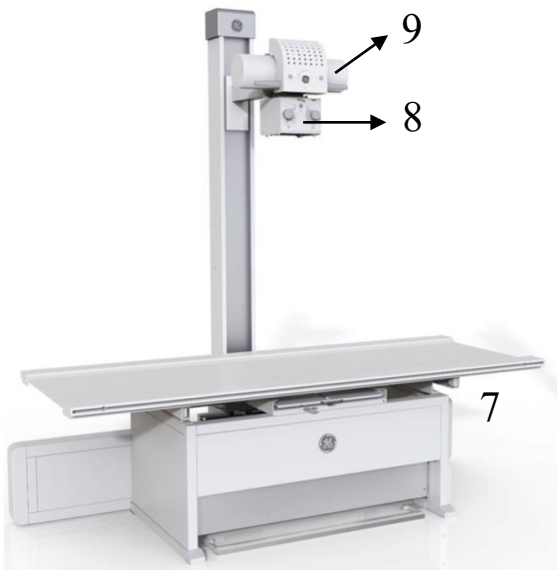

7

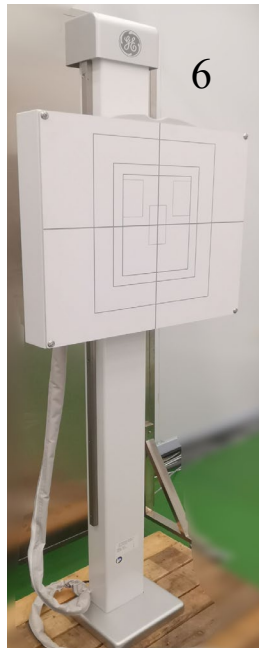

6

Figure 1-2 System Component Identification

<b>Item</b>	<b>Component</b>	<b>Part Number</b>
1	Console	5392595-ROHS
2	Console Stand (optional)	5395321
3	Generator (Jedi 50 R1T with AEC)	2212259-2
5	PDU	5543166
6	SGW-2 Gen3 Standard Wall Stand	5395310-3
7	SGT-2 Gen3 Standard Integrated Table	5395277-3
8	XS-1A Manual Collimator	5392365-ROHS
9	Tube 5331186 (50kw)	5331186

**Table 1-1 XR 6000 System Component Identification**

Note: If console stand is not choosed and purchased, please request the purchaser to provide other type of pedestal.

This page is intentionally left blank.

# Chapter 2 - Room Requirements

## Section 1.0 Environmental Requirements

### 1.1 Relative Humidity and Temperature

Product or Component	Relative Humidity ( 无冷凝 )				Temperature			
	In-Use		Storage		In-Use		Storage	
	Min	Max	Min	Max	Min	Max	Min	Max
Integrated Table	30%	80%	20%	90%	+10° C	40° C	-20° C	+70° C
Wall Stand	30%	80%	20%	90%	+10° C	40° C	-20° C	+70° C
Generator	30%	80%	10%	90%	+10° C	40° C	-20° C	+70° C
PDU	30%	80%	20%	90%	+10° C	40° C	-20° C	+70° C
Console	30%	80%	20%	90%	+10° C	40° C	-20° C	+70° C
Tube	30%	80%	20%	90%	+10° C	40° C	-20° C	+70° C

**Table 2-1 Environmental Requirements (Relative Humidity and Temperature)**

**Limits for rates of change**

<u>In-Use</u>	<u>Storage</u>
< 10° C/hour	< 20° C/hour
< 30% /hour	< 30% /hour

Note: STORAGE values only refer to equipment that is still in shipping containers. If the equipment is partially or completely installed, refer to IN-USE values.

## 1.2 Altitude and Atmospheric Pressure

Product or Component	Altitude				Atmospheric Pressure			
	In-Use		Storage		In-Use		Storage	
	Min	Max	Min	Max	Min	Max	Min	Max
Integrated Table	-100 m (-328 ft.)	3000 m (9842 ft.)	-100 m (-328 ft.)	15000 m (49212 ft.)	10 psi (69 kPa)	15.4 psi (106 kPa)	7 psi (48 kPa)	15.4 psi (106 kPa)
Wall Stand	-100 m (-328 ft.)	3000 m (9842 ft.)	-100 m (-328 ft.)	15000 m (49212 ft.)	10 psi (69 kPa)	15.4 psi (106 kPa)	7 psi (48 kPa)	15.4 psi (106 kPa)
Generator	-100 m (-328 ft.)	3000 m (9842 ft.)	-100 m (-328 ft.)	15000 m (49212 ft.)	10 psi (70 kPa)	15.4 psi (106 kPa)	7 psi (50 kPa)	15.4 psi (106 kPa)
PDU	-100 m (-328 ft.)	3000 m (9842 ft.)	-100 m (-328 ft.)	15000 m (49212 ft.)	10 psi (69 kPa)	15.4 psi (106 kPa)	7 psi (48 kPa)	15.4 psi (106 kPa)
Console	-100 m (-328 ft.)	3000 m (9842 ft.)	-100 m (-328 ft.)	15000 m (49212 ft.)	10 psi (70 kPa)	15.4 psi (106 kPa)	7 psi (50 kPa)	15.4 psi (106 kPa)
Tube	-100 m (-328 ft.)	3000 m (9842 ft.)	-100 m (-328 ft.)	15000 m (49212 ft.)	10 psi (70 kPa)	15.4 psi (106 kPa)	7 psi (50 kPa)	15.4 psi (106 kPa)

Table 2-2 Environmental Requirements (Altitude and Atmospheric Pressure)

**Limits for rates of change:**

<u>In-Use</u>	<u>Storage</u>
< 1.8 hPA / hour	< 76 hPA / hour

Note: STORAGE values only refer to equipment that is still in shipping containers. If the equipment is partially or completely installed, refer to IN-USE values.

## 1.3 Heat Output

Continuous power consumption and peak power consumption of this system:

- 6kW Continuous output
- 75kW Peak output

PRODUCT OR COMPONENT	HEAT OUTPUT MAX	HEAT OUTPUT Idle
Generator	891.36	261
PDU	500	145
Console	20	6
X-ray Tube	1089.44	319
<b>Total System Output</b>	<b>2500.80</b>	<b>731</b>

Table 2-3 Heat Outputs by Components

## 1.4 Acoustic Output

COMPONENT	SOUND OUTPUT (dBA)	
	IN-USE (measured 1m from any point in system)	STAND-BY (measured 1m from any point in system)
System	< 65	< 55

Table 2-4 Acoustic Output

## 1.5 Radiation Protection

Because X-ray equipment produces radiation, special precautions may need to be taken or special site modifications may be required. The General Electric Company does not make recommendations regarding radiation protection. It is the purchasers responsibility to consult a radiation physicist for advice on radiation protection in X-ray rooms.

## Section 2.0 Structural Requirements

### 2.1 Door Size Requirements

Minimum door sizes also apply to hallway and elevator. [Chapter 5 - - Product Characteristics](#), for additional details.

**Door Height:** The minimum door height to accommodate the WallStand is 150 cm.

**Door Width:**

- The minimum door width to accommodate the Table is: 100 cm.
- The minimum door width is calculated based on a straight-in approach requiring a 2.5 m wide corridor. Minimum widths will change based on narrower corridors.

### 2.2 Floor Requirements

The preferred method of installing the table and Basic wall stand is to use the provided floor anchors.

#### 2.2.1 Floor Requirements when using provided Floor Anchors

**CAUTION**

**Potential for Injury and/or Equipment Damage:**

**Anchors must be a minimum of 75mm from any concrete edge including ducts and cracks. In addition, the general condition of the concrete in the immediate mounting area should be inspected to ensure that anchors will be set in good quality concrete.**

### 2.2.1.1 Table

The Table Assembly is placed on the floor, which must accept the weight and the weight/area defined in [Chapter 5, Section 3.1 - Floor Loading and Recommended Mounting Methods](#).

- The weight of the complete stand table is 355kg.
- The ground surface must be approximately level.
- The Table system must be attached to the floor.

The floor bearing the system must be concrete and the thickness to be determined by a Structural Engineer to properly support the equipment loads. The supplied anchors require a minimum embedment of 55 mm into the concrete. If the floor thickness is less than 75 mm, it is recommended that the unit be secured using a through-bolt method with a reinforcement plate on the back side. For additional details, see [Chapter 5, Section 3.1 - Floor Loading and Recommended Mounting Methods](#).

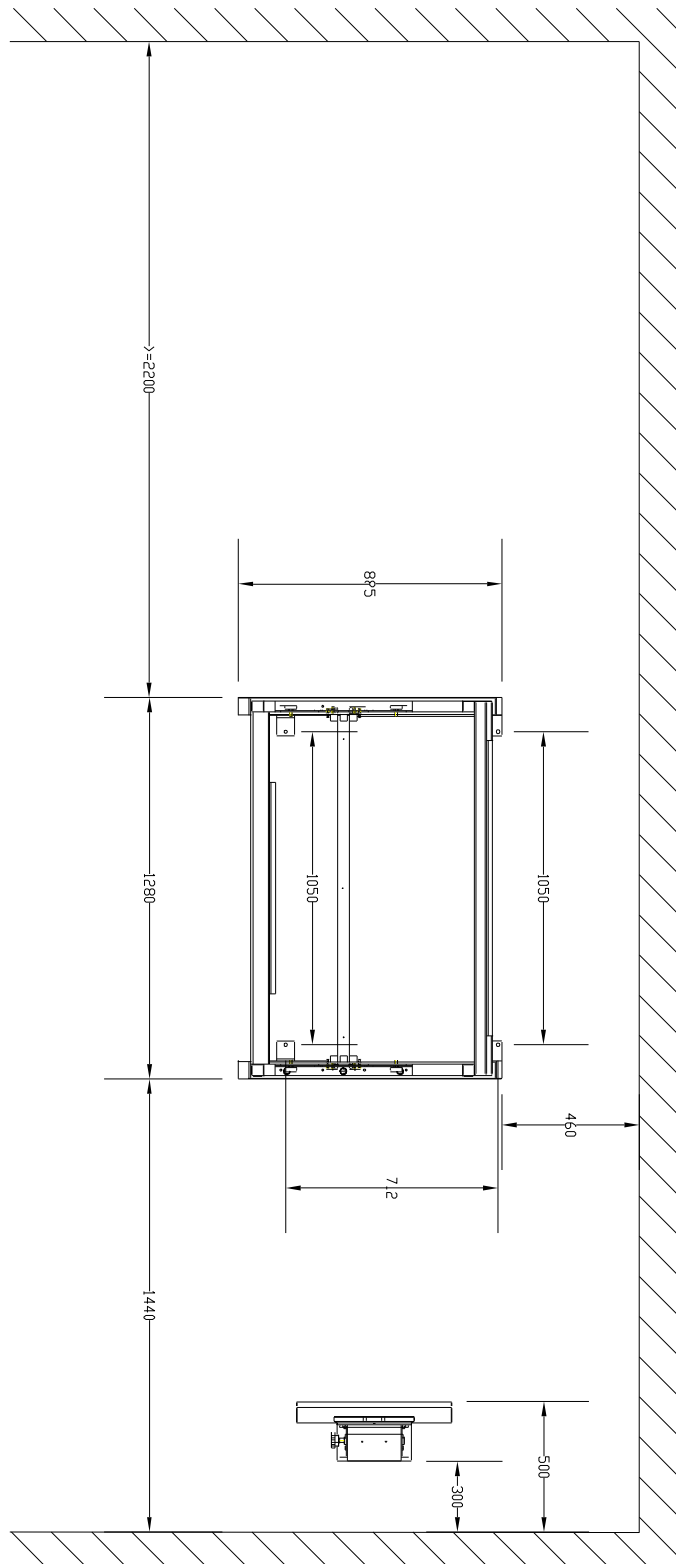

Figure 2-1 Floor Mounting - Table Assembly (Basic)

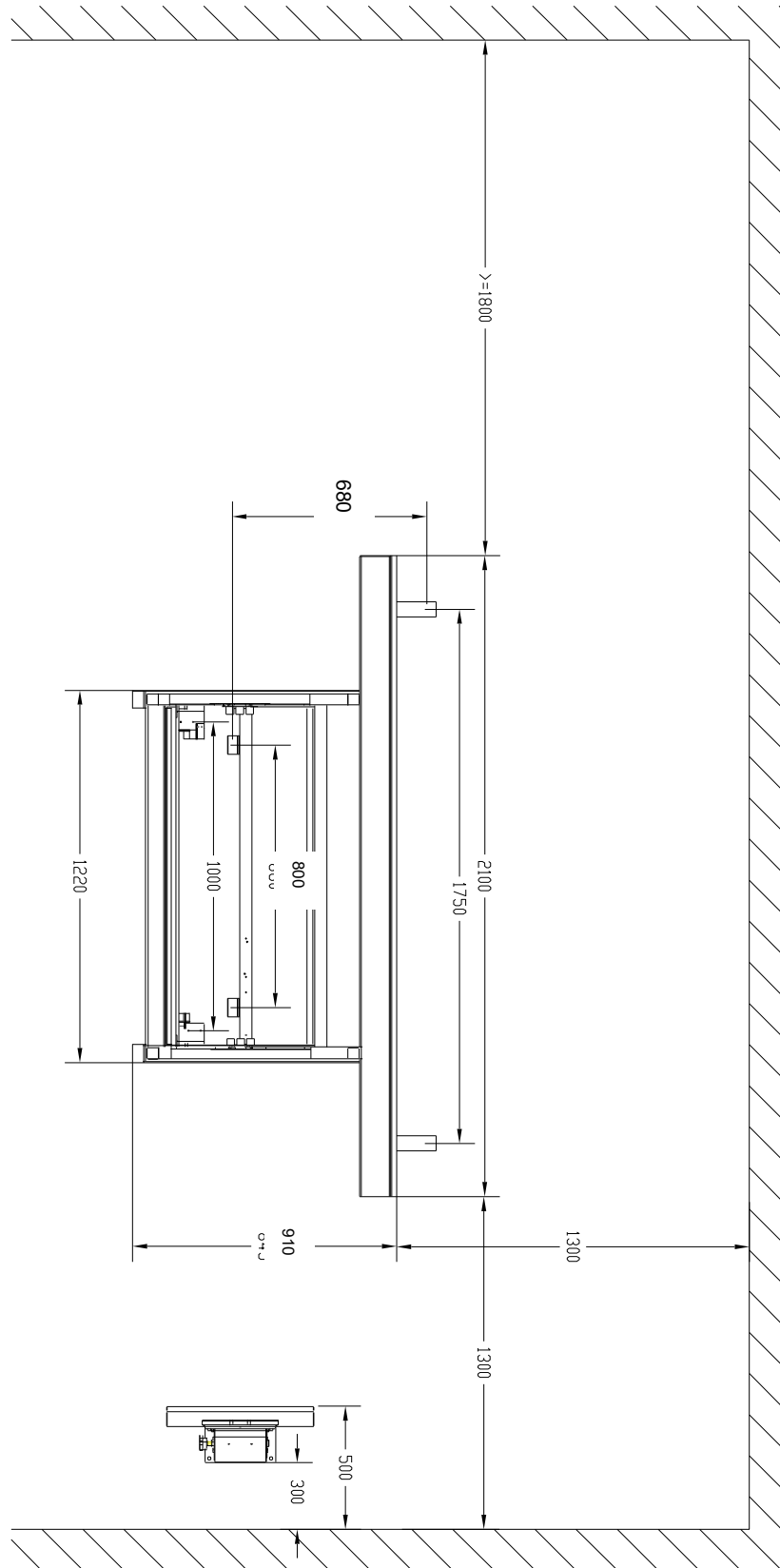

Figure 2-2 Floor Mounting - Table Assembly (Standard)

### 2.2.1.2 Wall Stand

The Wall Stand Assembly is placed on the floor, which must accept the weight and the weight/area defined in [Chapter 5, Section 3.1 - Floor Loading and Recommended Mounting Methods](#).

- The weight of the complete Basic wall stand is 70 kg and Standard wall stand is 75kg.
- The ground surface must be approximately level.
- The Wall Stand system must be attached to the floor.



**Concrete area for wall stand installation should be 0.1 m<sup>2</sup>.**

The floor bearing the system must be concrete and the thickness to be determined by a Structural Engineer to properly support the equipment loads. The supplied anchors require a minimum embedment of 55 mm into the concrete. If the floor thickness is less than 75 mm, it is recommended that the unit be secured using a through-bolt method with a reinforcement plate on the back side. For additional details, see [Chapter 5, Section 3.1 - Floor Loading and Recommended Mounting Methods](#).

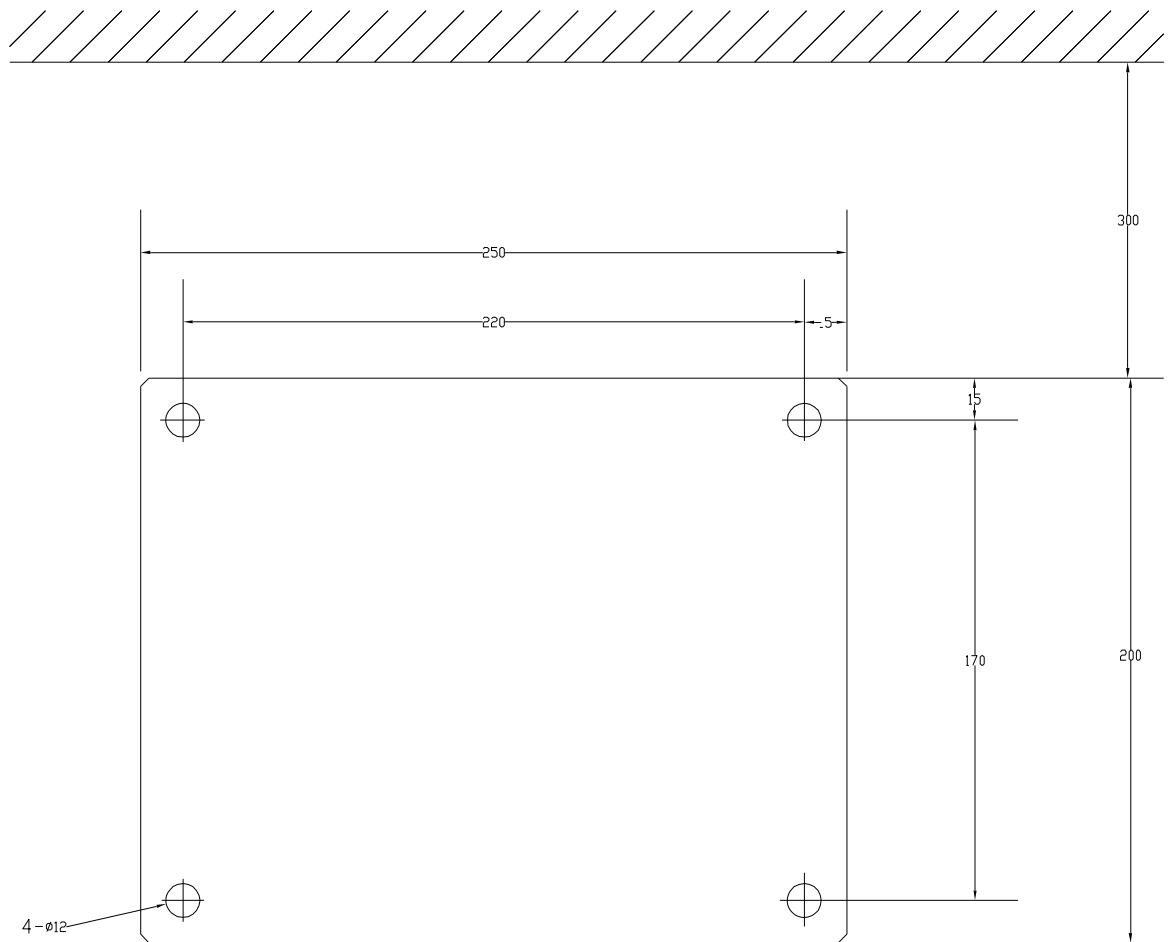

Figure 2-3 Floor Mounting - Wall Stand

### 2.2.1.3 Console Pedestal (optional)

The Console Pedestal is placed on the floor, which must accept the weight and the weight/area defined in [Chapter 5, Section 3.1 - Floor Loading and Recommended Mounting Methods](#).

- The weight of the console with pedestal is 10.5 kg
- The ground surface must be approximately level.

- The Console Pedestal must be attached to the floor.

**CAUTION**

Concrete area for console pedestal installation should be 0.2 m<sup>2</sup>.

The floor bearing the system must be concrete and the thickness to be determined by a Structural Engineer to properly support the equipment loads. The supplied anchors require a minimum embedment of 35 mm into the concrete. If the floor thickness is less than 55 mm, it is recommended that the unit be secured using a through-bolt method with a reinforcement plate on the back side. For additional details, see [Chapter 5, Section 3.1 - Floor Loading and Recommended Mounting Methods](#).

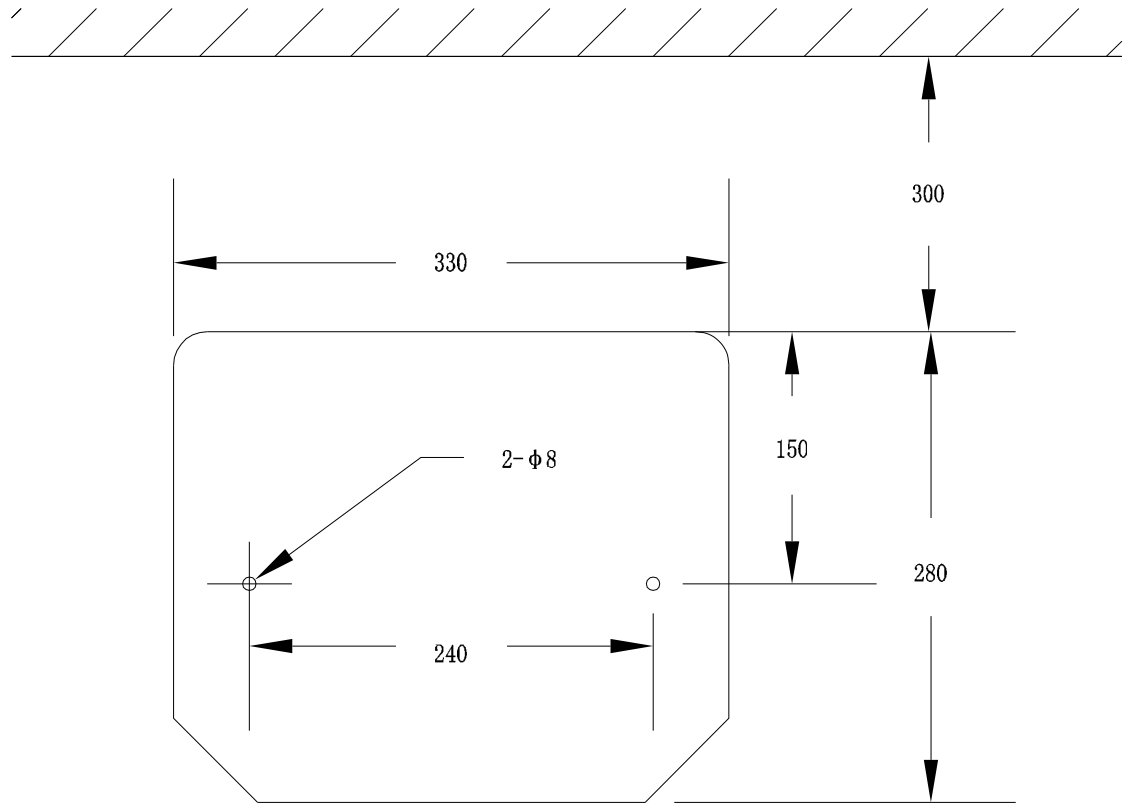

Figure 2-4 Floor Mounting - Console Pedestal

### 2.2.2 Service Access Requirements

Allow appropriate space for service access of equipment, per country and regional requirements.

This page is intentionally left blank

# Chapter 3 - Planning Electrical Connections

## Section 1.0 Routing Cables

### 1.1 General

Minimize cable length between the line disconnect and the System Cabinet power unit to reduce voltage regulation problems and wiring costs.

For information about the cables supplied with your system, please refer to [Chapter 8 - - System Cable Information](#).

### 1.2 Conduit

Using conduit imposes some important considerations when used with this system. Of primary concern, the majority of cables used are pre-terminated. Pre-termination greatly simplifies interconnection but makes cable-pulling difficult because of the added dimensions of the connectors.

Conduit must be large enough to pass the cable and connector through with all other cables already in the conduit. Also, the size of conduit chosen must allow for future growth. There is the possibility of additional cables being added later as the system is developed and options are added.

The use of conduit is recommended for cables running overhead between rooms, especially when a diagonal run provides the shortest cable path.

### 1.3 Electrical Ducts

Electrical ducts have advantages, when used with a single room or two adjacent rooms. Electrical ducts combine cabling in a neat and functional appearance, with accessibility and room for expansion.

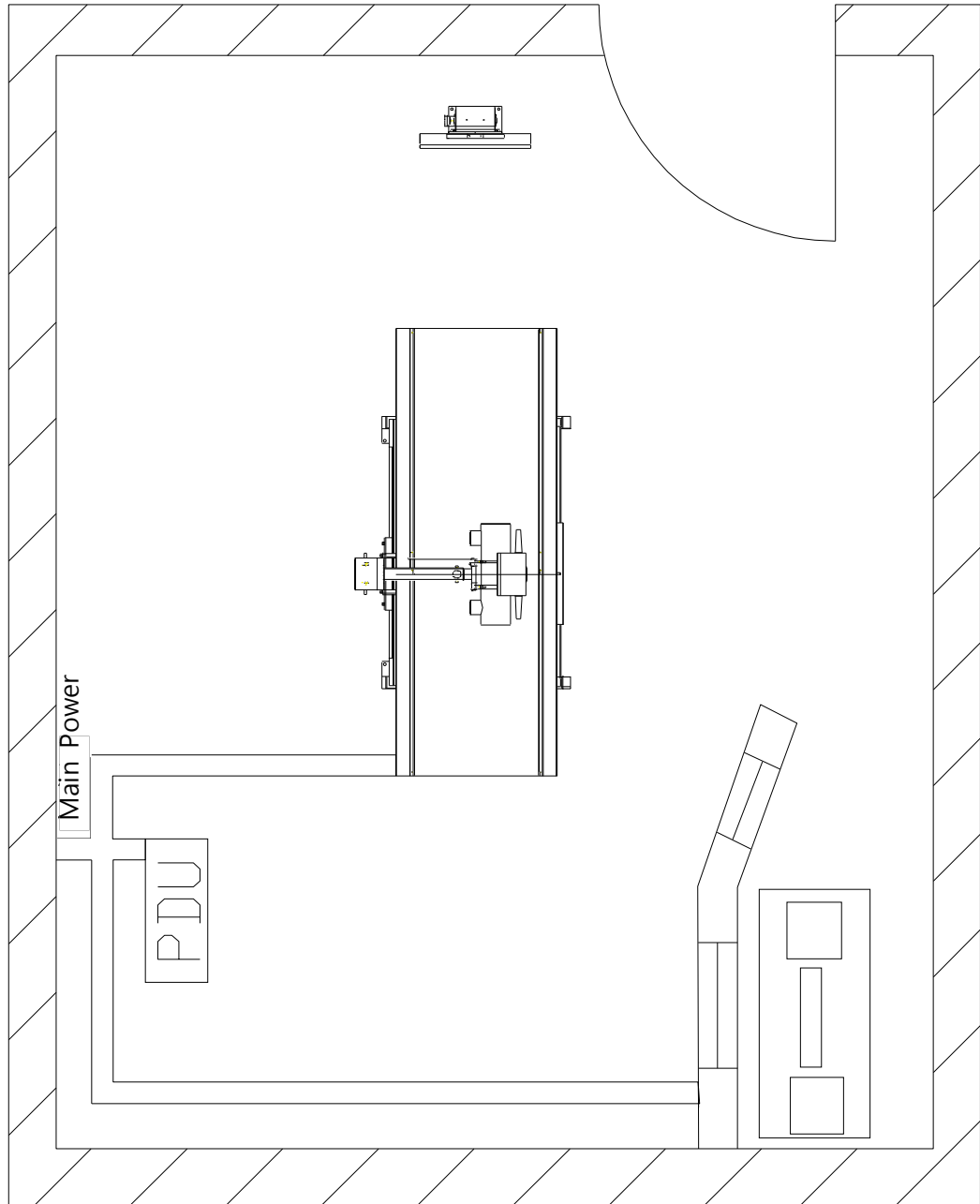

Figure 3-1 System Electrical Ducks (Basic)

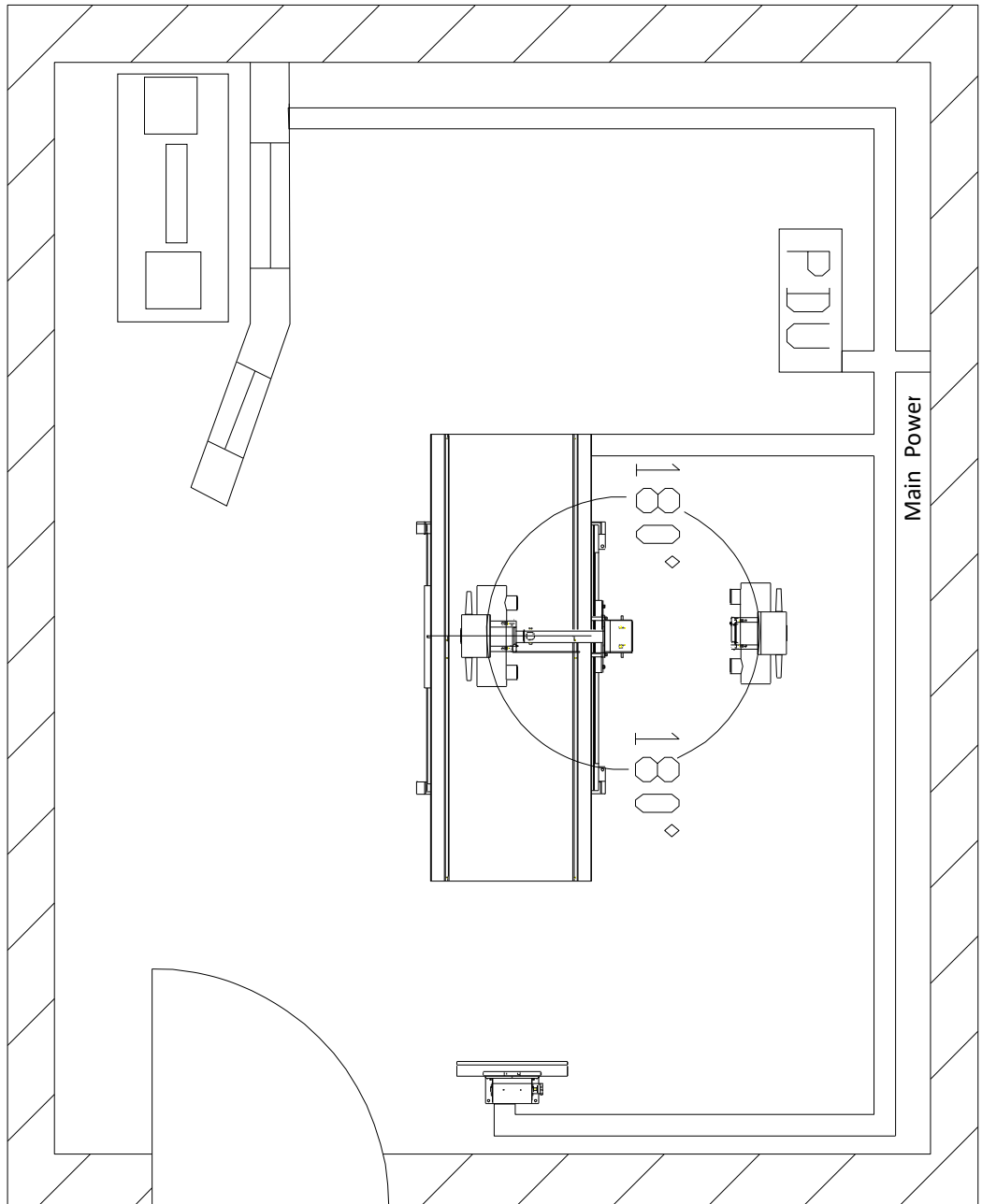

Figure 3-2 System Electrical Ducts (Standard)

## 1.4 Power Distribution

system power distribution consists of two major components that must either be customer supplied or GE Healthcare supplied. These are:

- Feeder power from Hospital distribution center to the Power Distribution Unit (PDU).
- Power distribution from the Power Distribution Unit (PDU) to all the components in the system room.

Usually the feeder power from the Hospital distribution center is customer supplied and the power distribution within the system is supplied by GEHC.

Note:  
Additional  
Reference  
Material Exists

---

For hospital facility feeder power and ground requirements to the system power unit, refer to: [Chapter 4 - - System Facility Power & Grounds](#).  
For system power distribution from the System power unit, refer to MIS Map, see [Chapter 8 - - System Cable Information](#).

---

## Section 2.0 Master Interconnect System (MIS)

System interconnect cables are described in MIS (Master Interconnect System) documents shipped with the system. These documents specify all interconnections between components within the system and its options.

Note:  
Additional  
Reference  
Material Exists

---

For specific system interconnect maps and connection details, please refer to [Chapter 8 - - System Cable Information](#).

---

# Chapter 4 - System Facility Power & Grounds

## Section 1.0 Introduction

The purpose of this chapter is to ensure that the product is properly powered and grounded, thus ensuring the proper operation of the product installed. The information in this chapter should be adhered to, unless there are written deviations approved by GE Healthcare.

This chapter gives the sizes and procedures on how to power and ground your system. If these power and grounding instructions are not adhered to, proper operation cannot be guaranteed. Any cost associated and found to be a result of non-conformity, as stated in this chapter, may result in additional cost charged back to the institution and/or their contractor.

### NOTICE

**All system and sub-system power connections shall be made ONLY to power outlets that are connected to the system.**

All system component power connections must be made in accordance with the MIS Map, see [Chapter 8 - System Cable Information](#).

## 1.1 Power Quality

The electrical power, from its origination to the system, must adhere to the wire size and transformer sizes as prescribed in the installation drawings. The feeder voltage-drops, as well as the supplying power, must be within the given parameters. Sizing for feeder is usually calculated for a maximum of 2% voltage drop at the minimum voltage range. The actual feeder sizing may vary from the installation drawing for a facilities voltage.

Calculate feeder losses before you begin. Total feeder losses must be calculated to ensure that the losses are less than those specified in the installation drawings. Calculating the recommended minimum transformer sizing for feeding a system ensures the transformer losses are less than half of the maximum regulation for the system.

Regulation is the calculated voltage losses for the entire power distribution system (No-Load Voltage minus Full-Load Voltage) divided by the no-load voltage minus the system losses (Full-Load Voltage):

$$\text{Regulation} = \frac{\text{NoLoadVoltage} - \text{FullLoadVoltage}}{\text{FullLoadVoltage}} \times 100$$

In the X-ray room, there must be a lockable facility power disconnect. It must be installed electrically before the equipment, for the purpose of locking out the power. This must be done before service to the high voltage system is performed.

## 1.2 Electrical Requirements

**NOTICE**

In China, all cables used to provide system power and ground must be CCC certified.

**NOTICE**

Only WYE connected power source are currently permitted, due to current system (generator) design.

All system components obtain their power from the Power Distribution Unit (PDU) under the system table. **Providing power and ground wires to the PDU are the responsibility of the customer.** As an aid, wire sizes for various lengths of the power supply cable are shown in the following tables. The procedures to replace power supply cable and ground cable can only be performed by qualified engineer.

**WARNING**

**PE CABLES SHALL HAVE THE DIAMETER NOT LESS THAN THE POWER SUPPLY CONDUCTOR, AND SHALL HAVE AN IMPEDENCE NOT MORE THAN 0.1 OHMS.**

### 1.2.1 System Electrical Requirements

#### 1.2.1.1 System Power Specifications

PARAMETER	JEDI GENERATOR - 32kW/50kW																																
Input Voltage	380/400/420/440/460/480 VAC WYE 3-Phase and ground without neutral																																
Required Power Source	WYE Distribution																																
Daily Voltage variations	+/- 10% (VAC) In this range, the generator will operate without any de-rating in accuracy.*																																
Line Impedance	The apparent line impedance guaranteed by the customer should be equal or less than the values indicated below, according to the voltage value and the commercial power of the generator. <table border="1"> <thead> <tr> <th colspan="2">Voltage range (V)</th> <th colspan="2">Line Impedance (ohms)</th> </tr> <tr> <th>3 phase</th> <th>32kW</th> <th>50kW</th> <th></th> </tr> </thead> <tbody> <tr> <td>380</td> <td>0.25</td> <td>0.15</td> <td></td> </tr> <tr> <td>400</td> <td>----</td> <td>0.16</td> <td></td> </tr> <tr> <td>420</td> <td>----</td> <td>0.18</td> <td></td> </tr> <tr> <td>440</td> <td>----</td> <td>0.20</td> <td></td> </tr> <tr> <td>460</td> <td>----</td> <td>0.22</td> <td></td> </tr> <tr> <td>480</td> <td>----</td> <td>0.24</td> <td></td> </tr> </tbody> </table>	Voltage range (V)		Line Impedance (ohms)		3 phase	32kW	50kW		380	0.25	0.15		400	----	0.16		420	----	0.18		440	----	0.20		460	----	0.22		480	----	0.24	
Voltage range (V)		Line Impedance (ohms)																															
3 phase	32kW	50kW																															
380	0.25	0.15																															
400	----	0.16																															
420	----	0.18																															
440	----	0.20																															
460	----	0.22																															
480	----	0.24																															
Inrush current	600 A																																
Normal Frequency	50/60Hz																																
Daily frequency variation	+/- 3Hz																																

Table 4-1 System Power Specifications

## 1.2.2 Recommended Power Supply

PDU Power Supply cable is offered by the customer, and also can be ordered from GE (S39222KP). Wire size for various lengths of the Power Supply cable are shown in the following tables.

Note: Power cable should be flexible enough to allow generator to roll back into table.

PARAMETER		THREE PHASE GENERATOR - 32kW	
Input Voltage		380 VAC	
Wire Size			
Length			
15 m (50 ft.)	10 mm <sup>2</sup>	(#8 AWG)	
30 m (100 ft.)	10 mm <sup>2</sup>	(#8 AWG)	
46 m (150 ft.)	16 mm <sup>2</sup>	(#6 AWG)	
60 m (200 ft.)	22 mm <sup>2</sup>	(#5 AWG)	

**Table 4-2 Minimum Wire Size 32 kW**

Phase	3
Nominal Line Voltage (Vac)	380
Voltage Range (Vac)	+/- 10%
Momentary Line Current (Amp)	70
Continuous Line Current (Amp)	7
Power Demand (kVA)	46
Frequency	47/53Hz

**Table 4-3 kVA Load Characteristics 32 kW**

PARAMETER	THREE PHASE GENERATOR - 50kW											
	380 VAC		400VAC		420VAC		440VAC		460VAC		480VAC	
Wire Size Length												
15 m (50 ft.)	10 mm <sup>2</sup>	(#8 AWG)	10 mm <sup>2</sup>	(#8 AWG)	10 mm <sup>2</sup>	(#8 AWG)	10 mm <sup>2</sup>	(#8 AWG)	10 mm <sup>2</sup>	(#8 AWG)	10 mm <sup>2</sup>	(#8 AWG)
30 m (150 ft.)	16 mm <sup>2</sup>	(#6 AWG)	16 mm <sup>2</sup>	(#6 AWG)	16 mm <sup>2</sup>	(#6 AWG)	16 mm <sup>2</sup>	(#6 AWG)	16 mm <sup>2</sup>	(#6 AWG)	16 mm <sup>2</sup>	(#6 AWG)
46 m (200 ft.)	22 mm <sup>2</sup>	(#5 AWG)	22 mm <sup>2</sup>	(#5 AWG)	22 mm <sup>2</sup>	(#5 AWG)	22 mm <sup>2</sup>	(#5 AWG)	22 mm <sup>2</sup>	(#5 AWG)	22 mm <sup>2</sup>	(#5 AWG)
60 m (100 ft.)	30 mm <sup>2</sup>	(#3 AWG)	30 mm <sup>2</sup>	(#3 AWG)	30 mm <sup>2</sup>	(#3 AWG)	30 mm <sup>2</sup>	(#3 AWG)	30 mm <sup>2</sup>	(#3 AWG)	30 mm <sup>2</sup>	(#3 AWG)

Table 4-4 Minimum Wire Size 50 kW

Phase	3	3	3	3	3	3
Nominal Line Voltage (Vac)	<b>380</b>	<b>400</b>	<b>420</b>	<b>440</b>	<b>460</b>	<b>480</b>
Voltage Range (Vac)	+/- 10%	+/- 10%	+/- 10%	+/- 10%	+/- 10%	+/- 10%
Momentary Line Current (Amp)	110	105	100	95	92	88
Continuous Line Current (Amp)	7	6.7	6.2	6	5.7	5.5
Power Demand (kVA)	70	70	70	70	70	70
Frequency	47/53Hz and 57/63Hz					

Table 4-5 kVA Load Characteristics 50 kW

### 1.2.3 Recommended Wall “Circuit-Breaker” Ratings

Power / Voltage	50 kW
380V	55 A / 600 V
400V	52 A / 600 V
420V	50 A / 600 V
440V	47 A / 600 V
460V	45 A / 600 V
480V	43 A / 600 V

**Table 4-6 Wall Breaker Parameter (Theoretical Current Values)**

Note: The main circuit breaker supplied by the customer must be sized in accordance to local regulations. Shunt trip circuit breaker required.

## 1.2.4 Wiring Electrical Power and Disconnects

This section provides additional data regarding power circuits the customer must provide, and internal electrical circuits necessary to supply the correct power to the system. Figure 4-1 shows the room power supply installed.

### 1.2.4.1 Room Power Supply

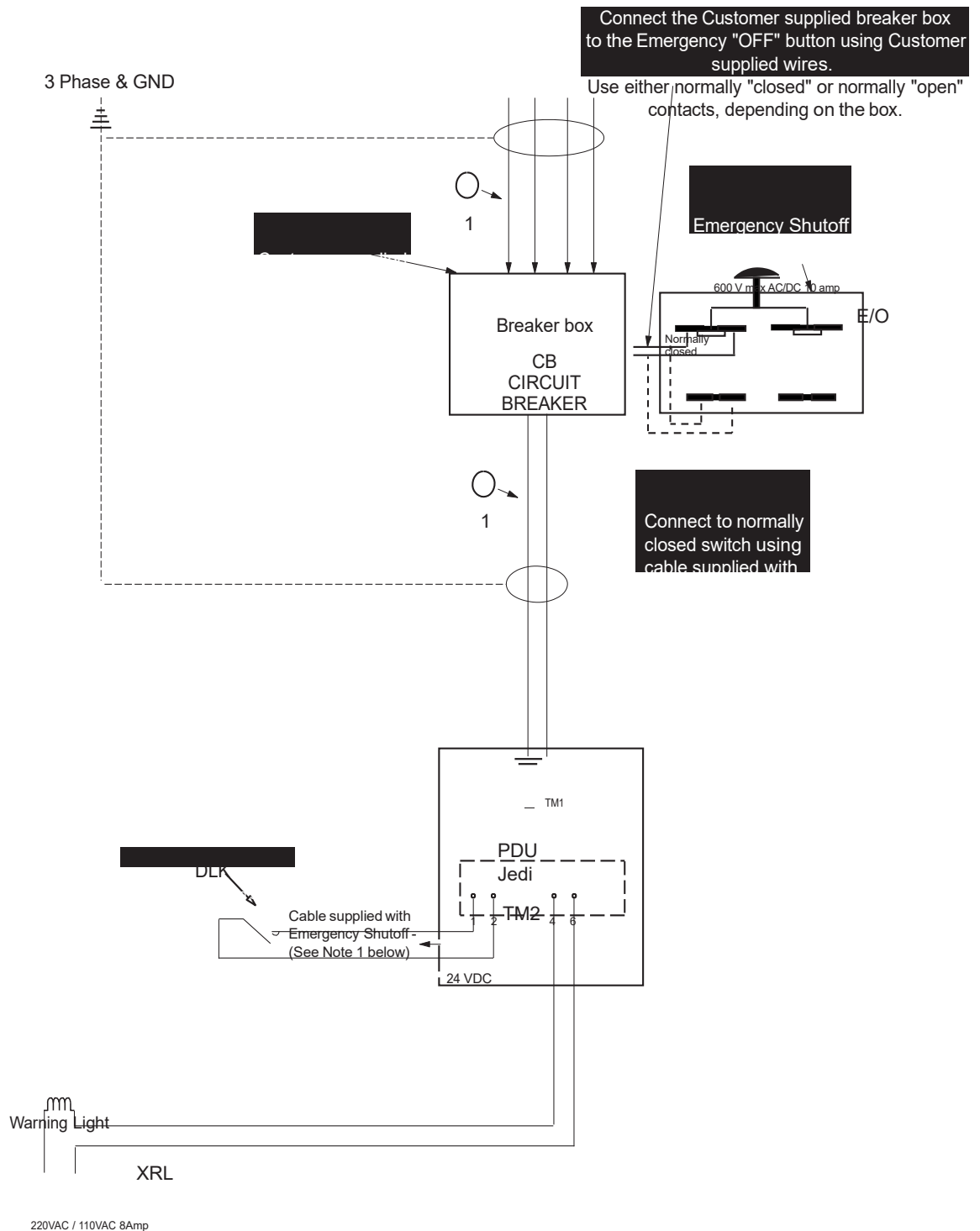

Figure 4-1 Room Power Supply (see Table 4-7 for Legend)

Key for Figure 4-1	Description
CB	Circuit breaker with remote trip (shunt) capabilities supplied by customer.
DLK <i>(see note below)</i>	Open-door detector (per local regulations).
XRL	Yellow X-ray emission indicator lamp above the room access door. 220 V in Europe/120 V in USA with 25 W max. bulb (per local regulations). Wires and light fixtures supplied by customer.

**Note:** Use only a multi conductor, shielded, PVC/PVC, UL TYPE CM cable. Alpha Wire. CQA10210637. This wire is found in GE Catalog Item A8091JH as a “bulk” roll of wire (60 Meters). Material consists of two AWG (19/0.0117 strand) conductors. Shields must be grounded at both ends.

Table 4-7 Legend for Figure 4-1

### 1.2.4.2 Multiple Emergency “OFF” Switches

Figure 4-2 shows how multiple emergency “OFF” switches could be wired.

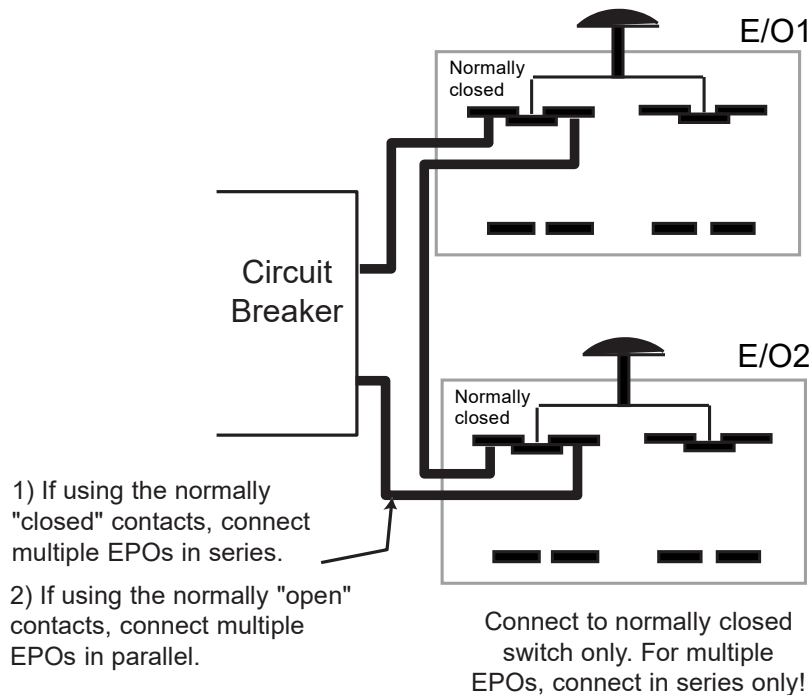

Figure 4-2 Wiring Multiple “Emergency OFF” (E/O) Switches

## Section 2.0 Electrical Grounds

### 2.1 System and Facility Grounds

The ground for this system must originate at the system's power source and be continuous (i.e., transformer or first access point of power into a facility, and be continuous to the system power disconnect in the room). Ground connection at the power source must be at the grounding point of the "Neutral/Ground" if a "Wye" transformer is used, or typical grounding points of a separately derived system. In the case of an external facility, it must be bonded to the facility ground point at the electrical service entrance.

The "system" ground can be spliced using "High Compression Fittings" but must be properly terminated at each distribution panel it passes through. When it is terminated, it must be connected into an approved grounding block. Incoming and outgoing grounds must terminate at this same grounding block. Grounds must only be terminated to approved grounding blocks. Grounds must never connect directly to the panels, frames or other materials in a cabinet or distribution panel (refer to [Figure 4-3](#)).

### 2.2 Recommended Ground Wire Sizes

The ground wire must be copper and never smaller than 10 AWG.

The ground wire impedance from the system disconnect (including the ground rod) measured to earth, must not exceed 2 ohms (as measured by one of the applicable techniques described in Section 4 of ANSI/IEEE Standard 142 - 1982). Refer to [Figure 4-3](#) and [Figure 5](#) for typical equipment and methods to measure the different portions of the 2 ohm impedance.

Note:  
Additional  
Reference  
Material Exists

For general system grounding requirements and information on establishing an equi-potential grounding system, refer to:

- Direction 46-014505, *Electrical Safety - Equipment Grounding*
- Direction 46-014546, *Electrical Safety - Leakage Currents*

For specific system grounding maps and connection details, refer to [Chapter 8 - - System Cable Information](#).

### 2.3 Final Checks, Before System Installation Can Begin

The customer must provide GE Healthcare or its representative (installation specialist) evidence that grounds and electrical power meet GE Healthcare' specifications.

Prior to product installation, a local service or installation specialist, to be determined by GEHC, will do a physical walk through of the exam suite to ensure the following:

- 1.) Ground wires are of the same size as the power feeder or 10 AWG, whichever is larger.
- 2.) Grounds at junction points are connected properly and securely to an approved ground bus.
- 3.) Grounds within an enclosure are tied together by copper wire or to an appropriate buss bar (i.e., separate buss bars within an enclosure must be tied together with copper wire of appropriate size).
- 4.) Grounds originate at the power source (i.e., transformer or entrance panel into facility).
- 5.) Ground wires measure less than 2 ohms to earth.

You may use the following form to record the results of that inspection.

GROUND IMPEDANCE MEASURED TO BE \_\_\_\_\_ OHMS

Inspector's Name and Date: \_\_\_\_\_

Customer's Name and Date: \_\_\_\_\_

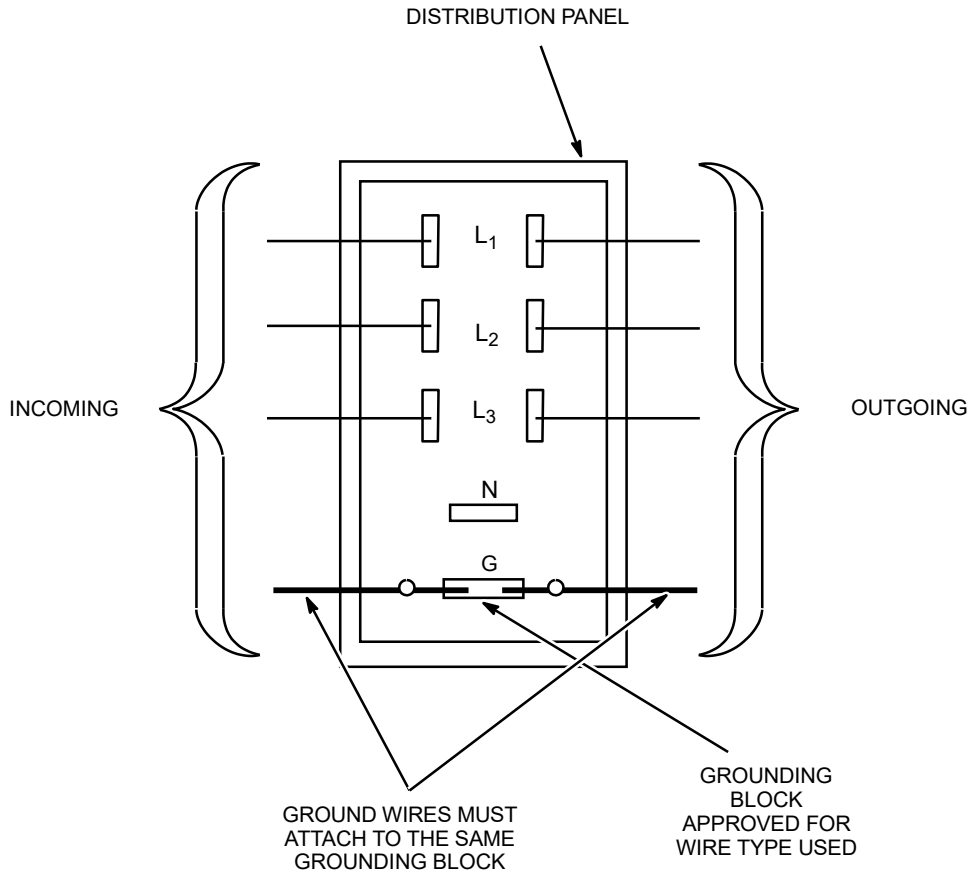
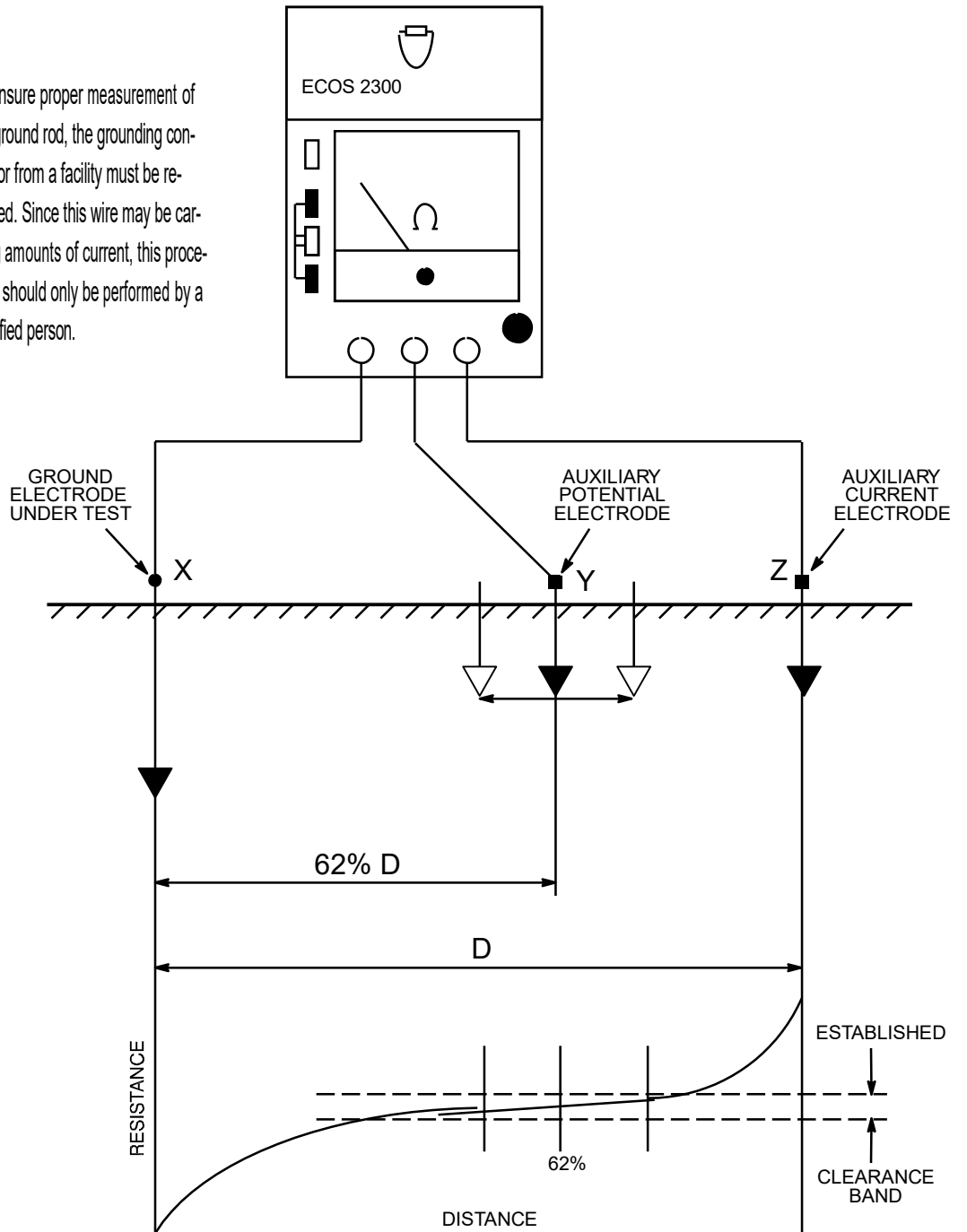

Figure 4-3 Ground Connection at Distribution Panel

To ensure proper measurement of the ground rod, the grounding conductor from a facility must be removed. Since this wire may be carrying amounts of current, this procedure should only be performed by a qualified person.



# Chapter 5 - Product Characteristics

## Section 1.0 Overview

Refer to this section for dimensional drawings for the components of the system. These components include:

- System - [Figure 5-1](#) through [Figure 5-2](#)
- Operator Console - [Figure 5-3](#).
- Integrated Table - [Figure 5-4](#) through [Figure 5-9](#).
- Radiographic Table - [Figure 5-10](#) through [Figure 5-12](#).
- Integrated Tube Stand - [Figure 5-13](#) through [Figure 5-14](#).
- Basic Wall Stand - [Figure 5-15](#) through [Figure 5-18](#).

Note: Drawings are not to scale. Dimensions are called out on each drawing.

## Section 2.0 System Components Dimensions and Weights

### 2.1 Dimensions

PRODUCT OR COMPONENT	DIMENSIONS		
	Width	Depth	Height
Operator Console:			
Console	340 mm	241 mm	60 mm
Console Pedestal	330 mm	380 mm	980 mm
Standard Integrated Table	2100 mm	1350 mm	2260 mm
Basic Integrated Table	2100 mm	1010 mm	2020 mm
Standard Wall Stand	655 mm	200 mm	1900 mm
Basic Wall Stand	550 mm	200 mm	1830 mm
PDU	716 mm	457 mm	589 mm

\*Showing: Mounting Holes, Cable Entrance, Air Vents, Service Access, Center of Gravity

Table 5-1 Product Physical Characteristics (Width / Depth / Height)



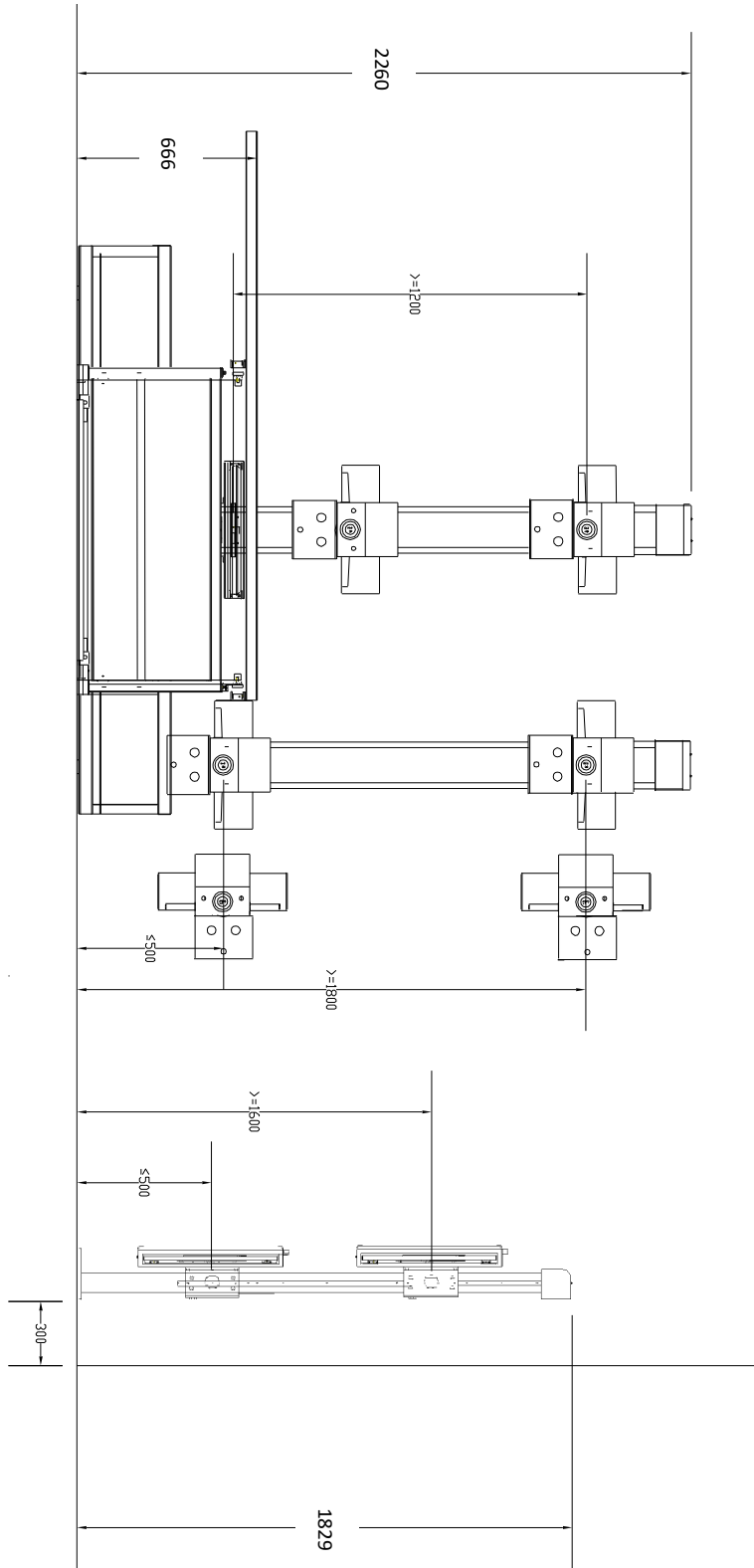

Figure 5-1 System Views (Standard)

## 2.2.2 Console

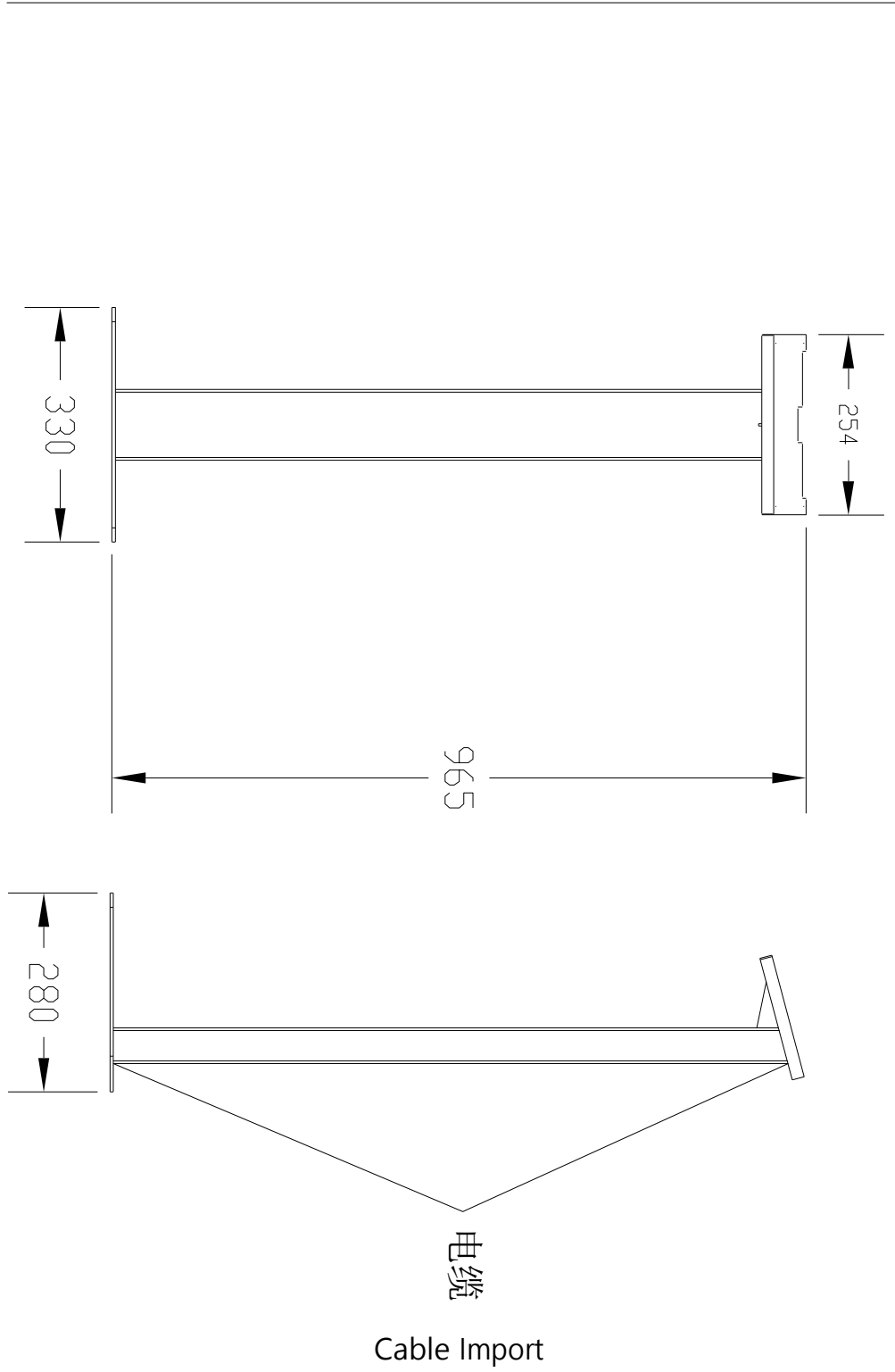

Figure 5-3 Console Size

### 2.2.3 Integrated Table

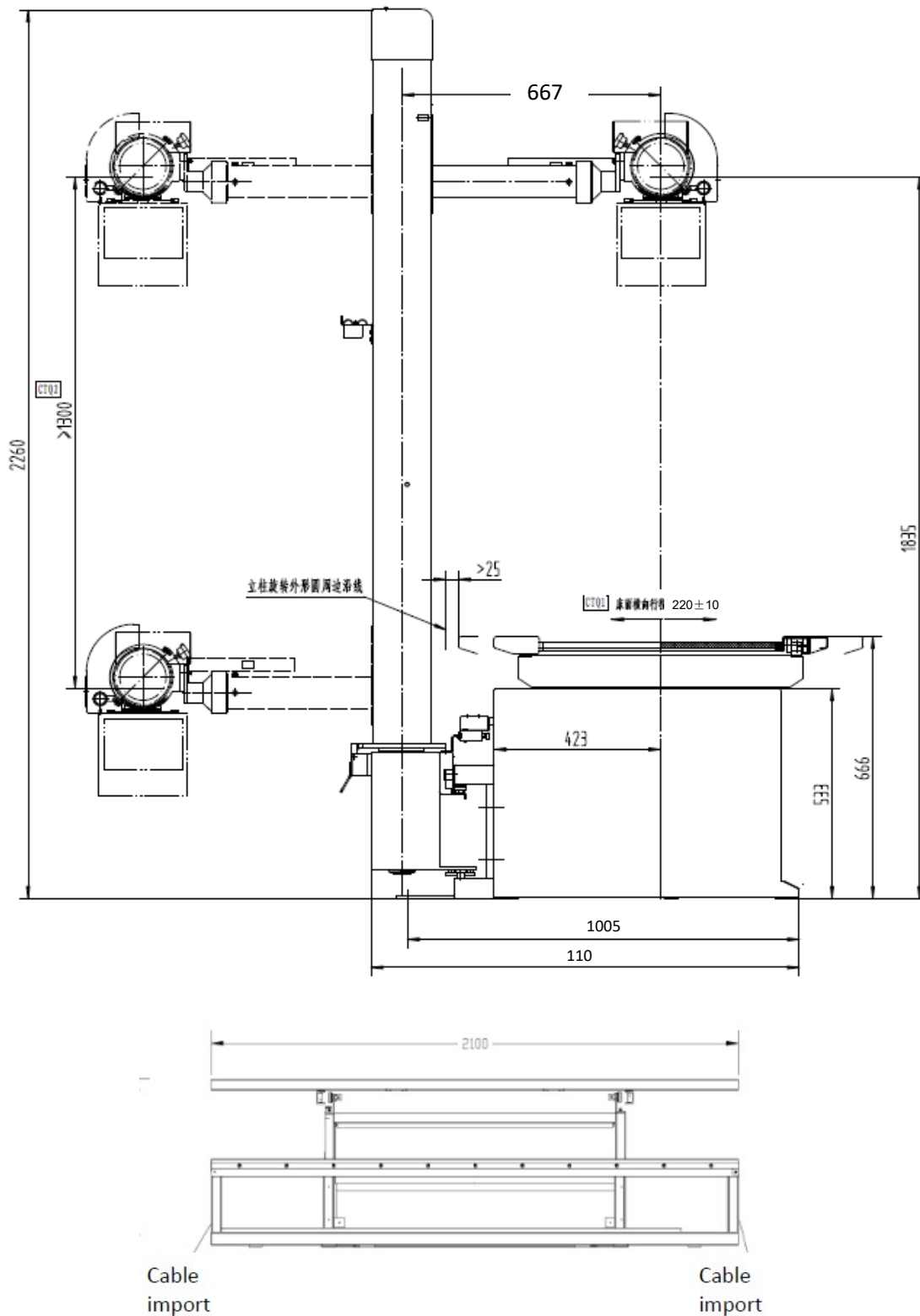

Figure 5-5 Integrated Table Side View (Standard)

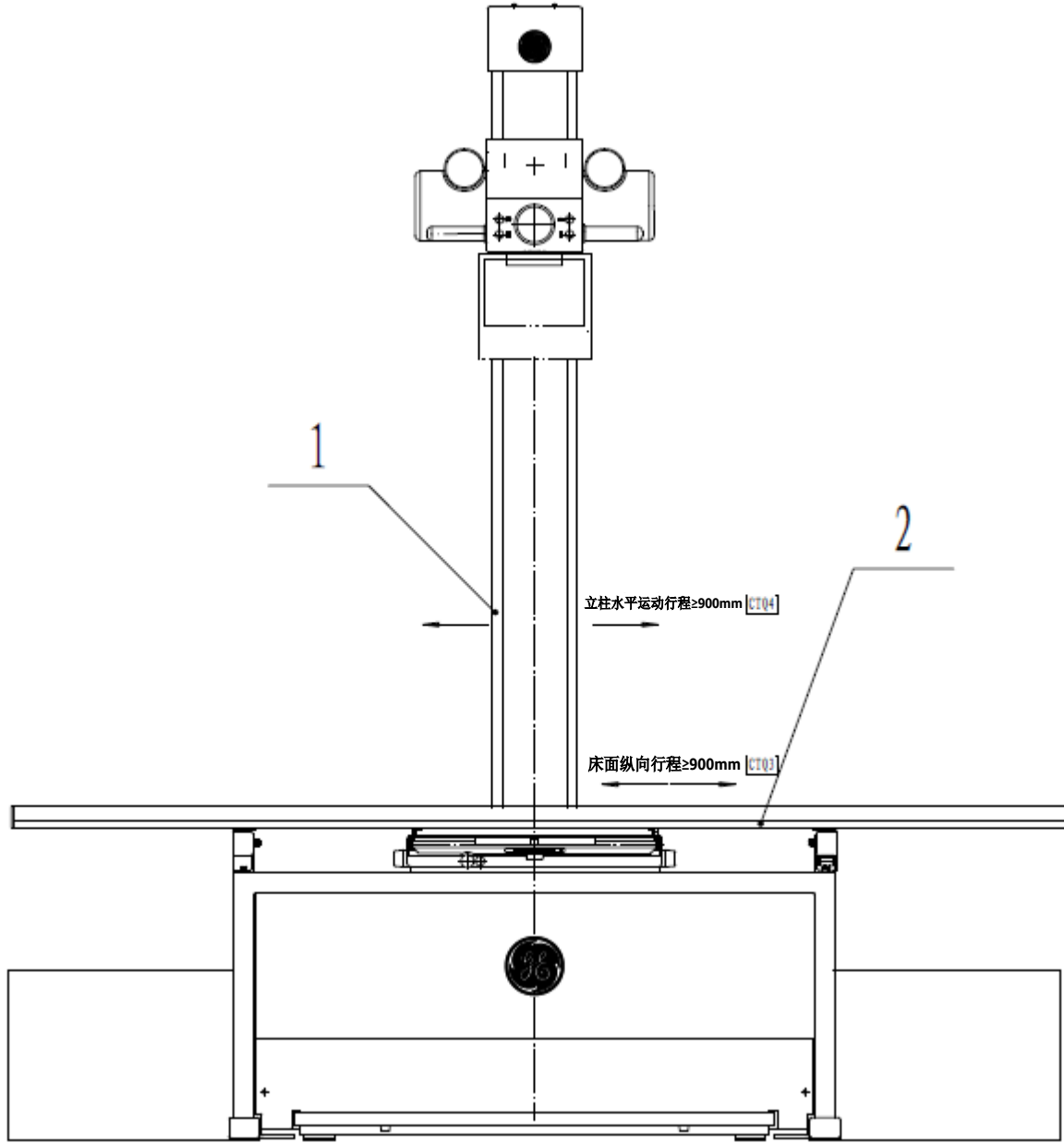

Figure 5-7 Integrated Table Front View (Standard)

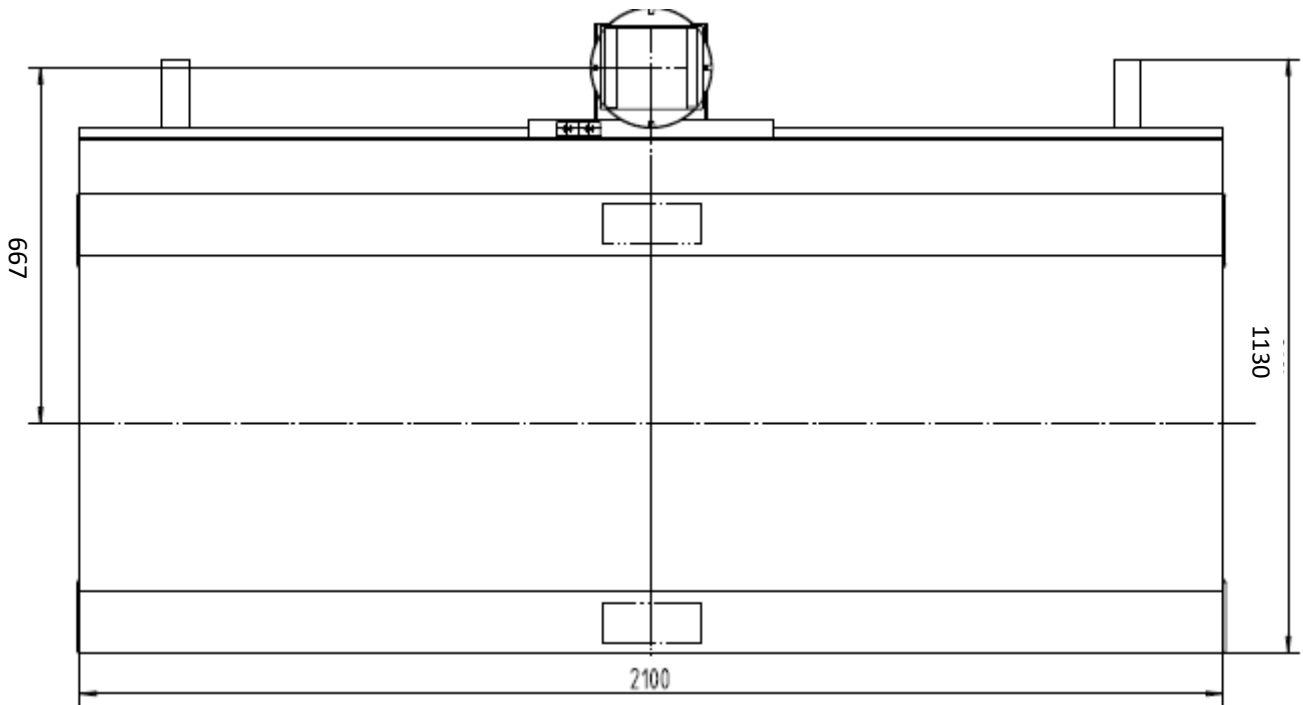

Figure 5-9 Integrated Table Top View (Standard)

### 2.2.3.1 Table

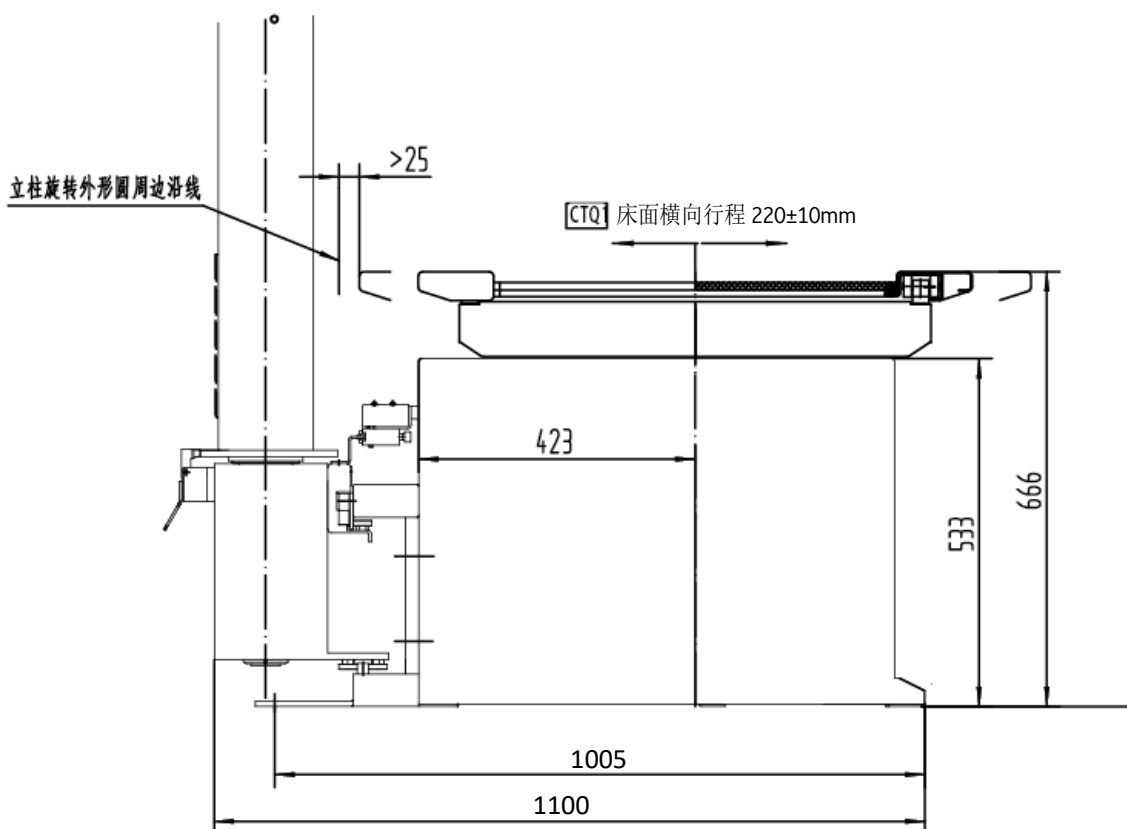
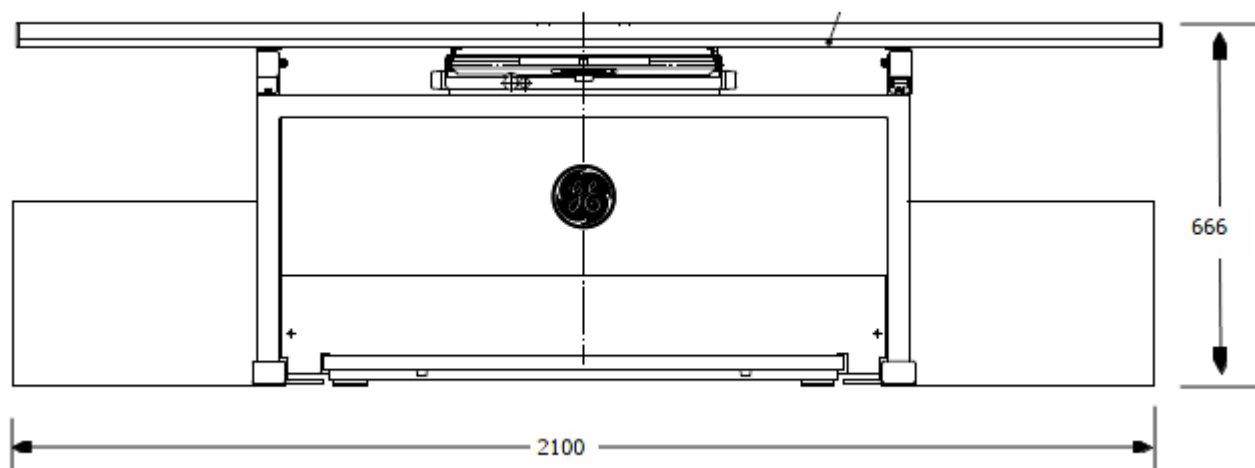

Figure 5-11 Table Dimensions (Standard)

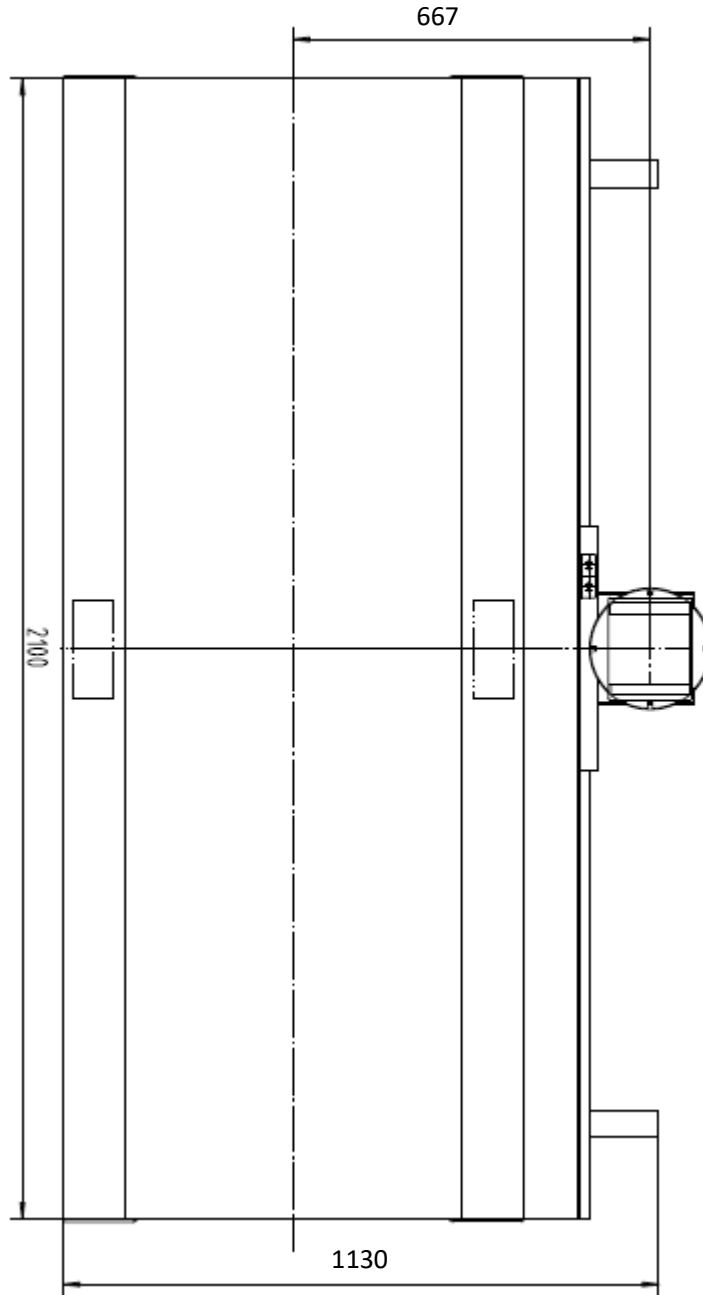

Figure 5-12 Table Top Dimensions

### 2.2.3.2 Tube Stand

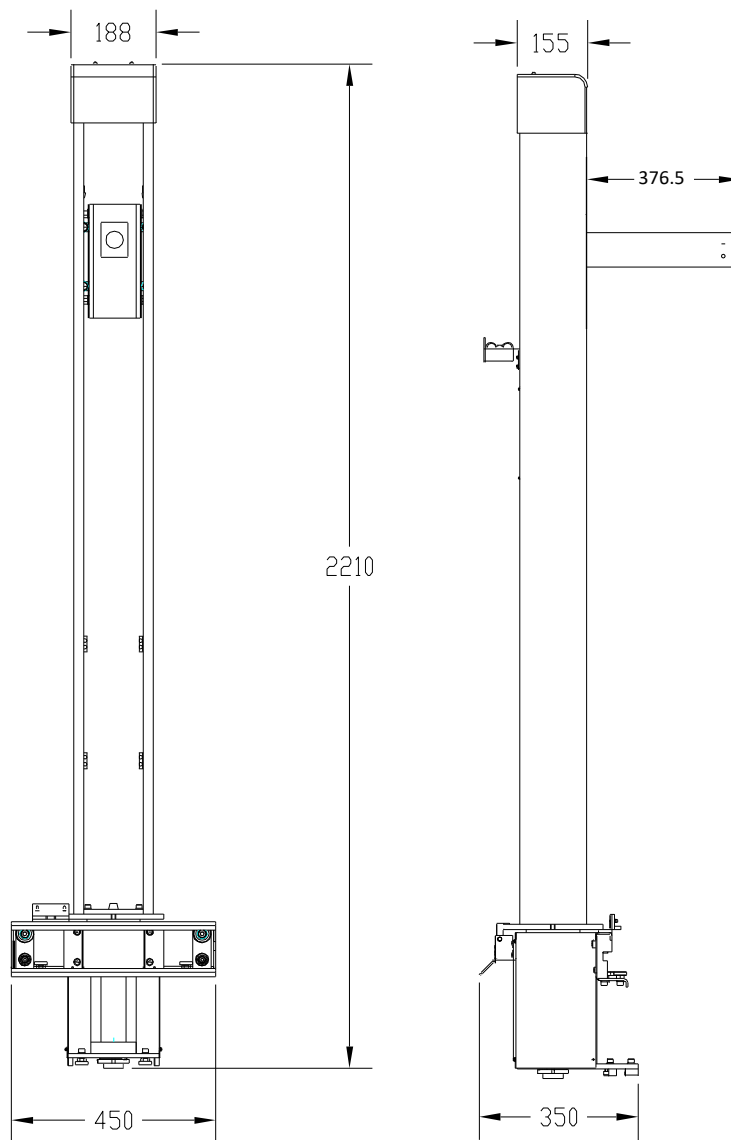

Figure 5-14 Tube Stand (Standard)

### 2.2.4 Wall Stand

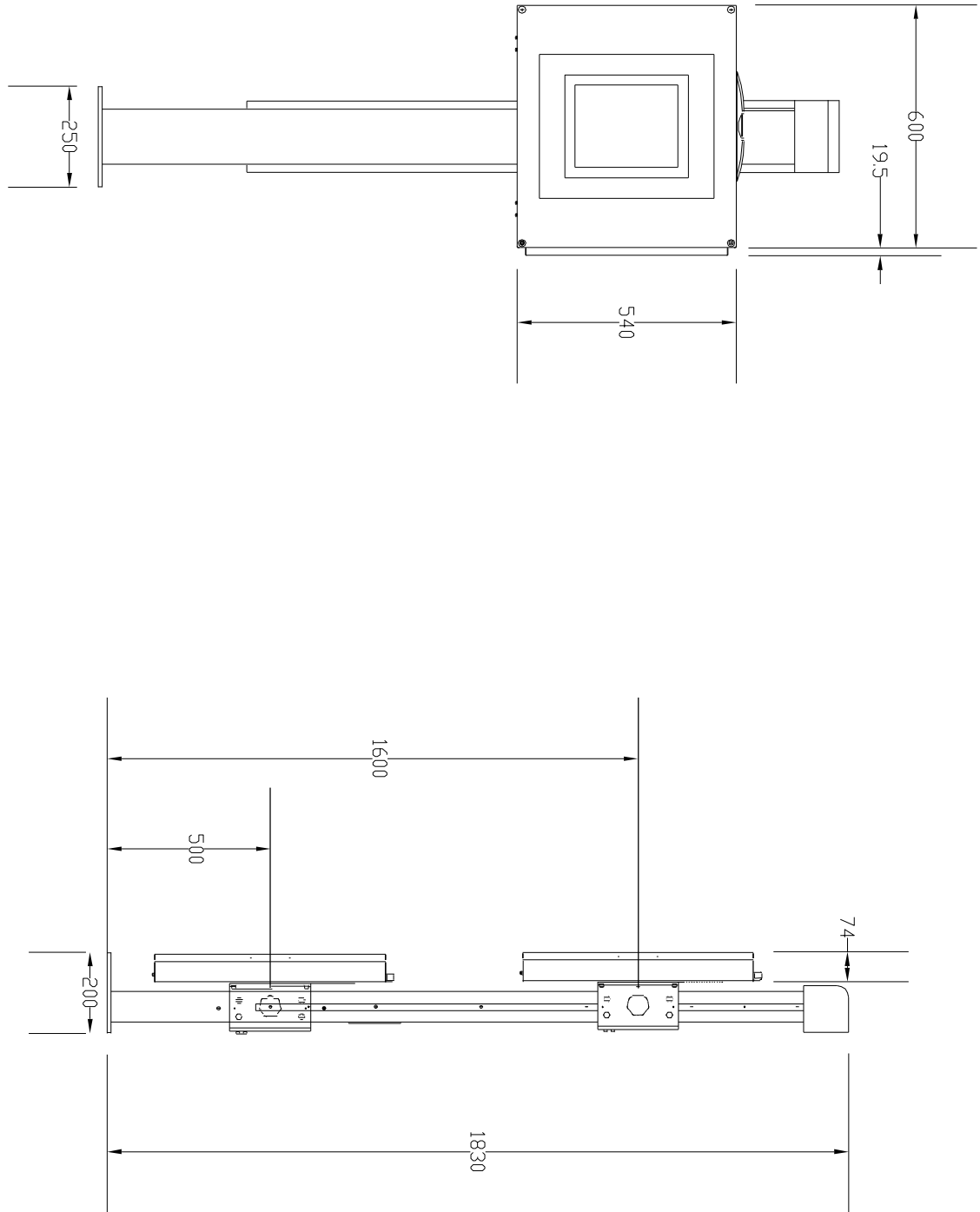

Figure 5-17 Standard Wall Stand Plan View

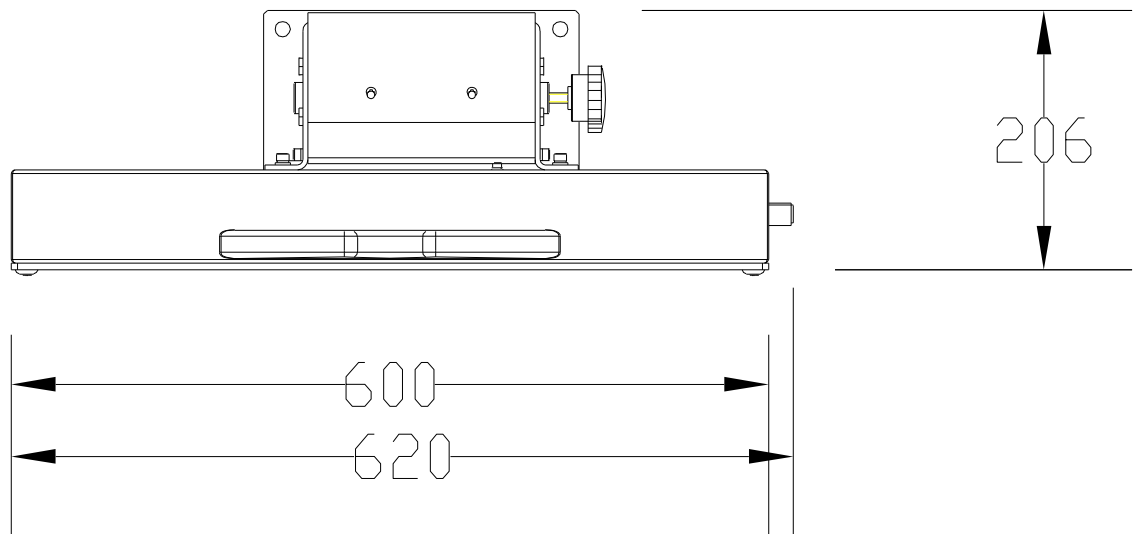

Figure 5-18 Standard Wall Stand Top View

### 2.2.5 PDU

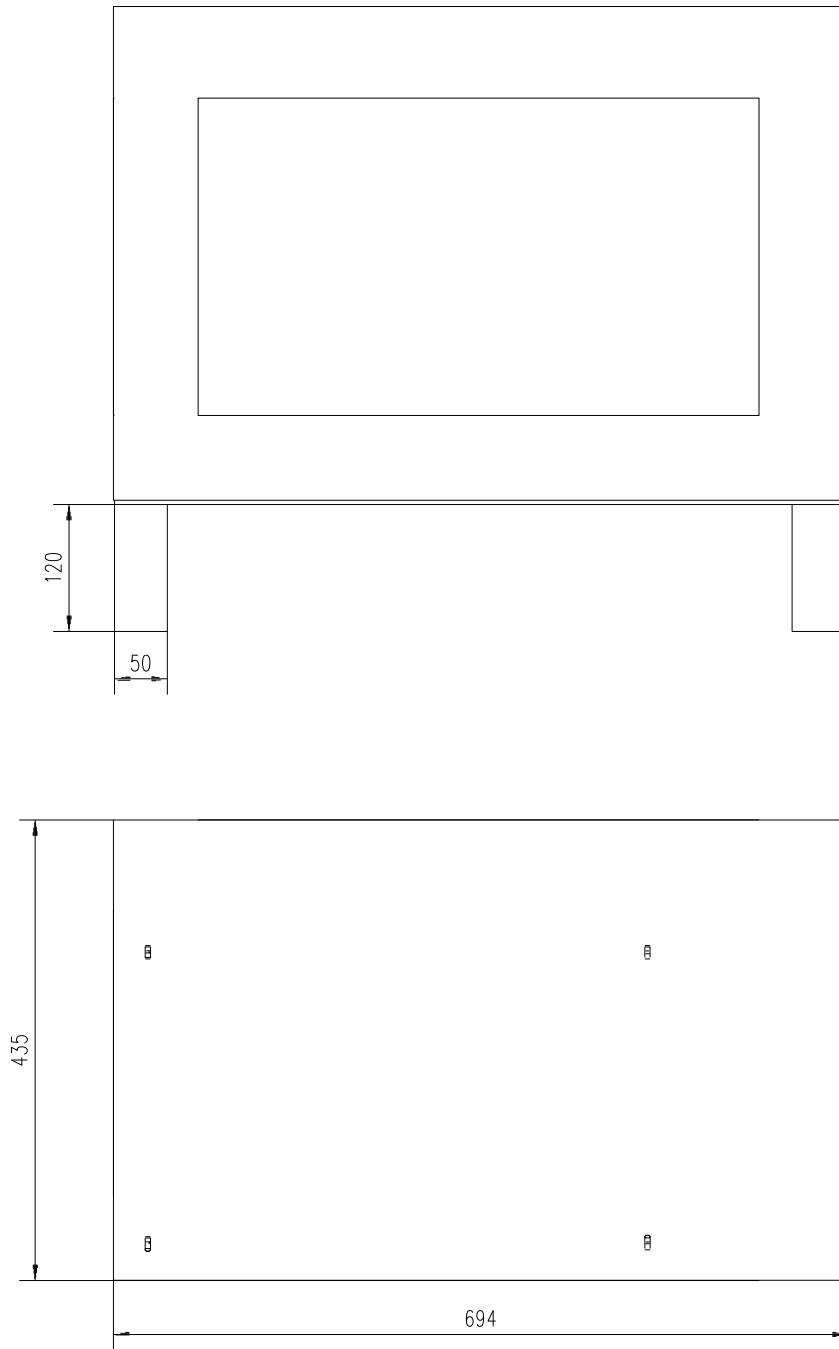

Figure 5-19 PDU Diagram

## Section 3.0 Positioning and Mounting Equipment

### 3.1 Floor Loading and Recommended Mounting Methods

PRODUCT OR COMPONENT	WEIGHT	LOAD BEARING AREA	WEIGHT/OCCUPIED AREA kg/m <sup>2</sup>	RECOMMENDED MOUNTING INFORMATION
Operator Console: Console Console Pedestal	1.4 kg 1.4kg+8.7kg	0.09 m <sup>2</sup>	109.3 kg/m <sup>2</sup>	Floor mounting Recommendations: (4) M6 X 60 mm anchors (supplied) Note: Please use a $\phi$ 7 bit
Standard Integrated Table	355kg Max.Patient Weight 220 kg	2.28 m <sup>2</sup>	252.2 kg/m <sup>2</sup>	Floor mounting Recommendations: (4) M10 X 100 mm anchors (supplied) Note: Please use a $\phi$ 10 bit
Standard Wall Stand	75kg	0.05m <sup>2</sup>	1500kg/m <sup>2</sup>	Floor mounting Recommendations: (4) M10 X 100 mm anchors (supplied) Note: Please use a $\phi$ 10 bit
PDU	122kg	0.006m <sup>2</sup>	20333kg/m <sup>2</sup>	Floor mounting Recommendations: Put on the floor directly

**Table 5-2 Product Physical Characteristics (weight)**

# Chapter 6 - Room Layout

## Section 1.0 Radiation Production

Because X-ray equipment produces radiation, you may need to take special precautions or make special site modifications. The General Electric Company does not make recommendations regarding radiation protection. It is the purchaser's responsibility to consult a radiation physicist for advisement on radiation protection in X-ray rooms.

## Section 2.0 Clinical Access

Make sure that you plan the room with the following clinical access requirements:

- Provide emergency egress path out of the room for patient, operators and service personal, per country and regional requirements.
- Provide easy access to the patient table. Stretchers and other mobile hospital equipment must reach the table quickly.
- Clinicians at the patient table must be able to communicate with assistants in the control area.
- Operators in the control area must have easy access to the Operator Console.
- Consult customer on the number and location of nonelectrical lines (air, oxygen, vacuum, water, etc.) in the radiographic room.
- Ensure there is enough space between the table and the Wall Stand to perform standing ankles, knees, etc.
- For the wallstand, ensure that the room layout is such that the tube can be centered on top of the horizontal detector.

## Section 3.0 Peripheral Equipment

Consult hospital personnel regarding additional space requirements for the following types of hospital equipment:

- Storage Cabinet
- Sinks
- Oxygen Stations
- Monitoring Equipment
- Crash Cart

## Section 4.0 Room Layout Drawings

See [Figure 6-2](#) for typical system room layouts.

Note: The room layout shows the minimum room size that system needs, but customers should be required to prepare a room according with local regulatory requirements.

Note: Please pay more attention that there must at least be 2200mm between the wall stand and one side of the radiographic table which facing to the wall stand. Standard tube stand and Standard wall stand system.

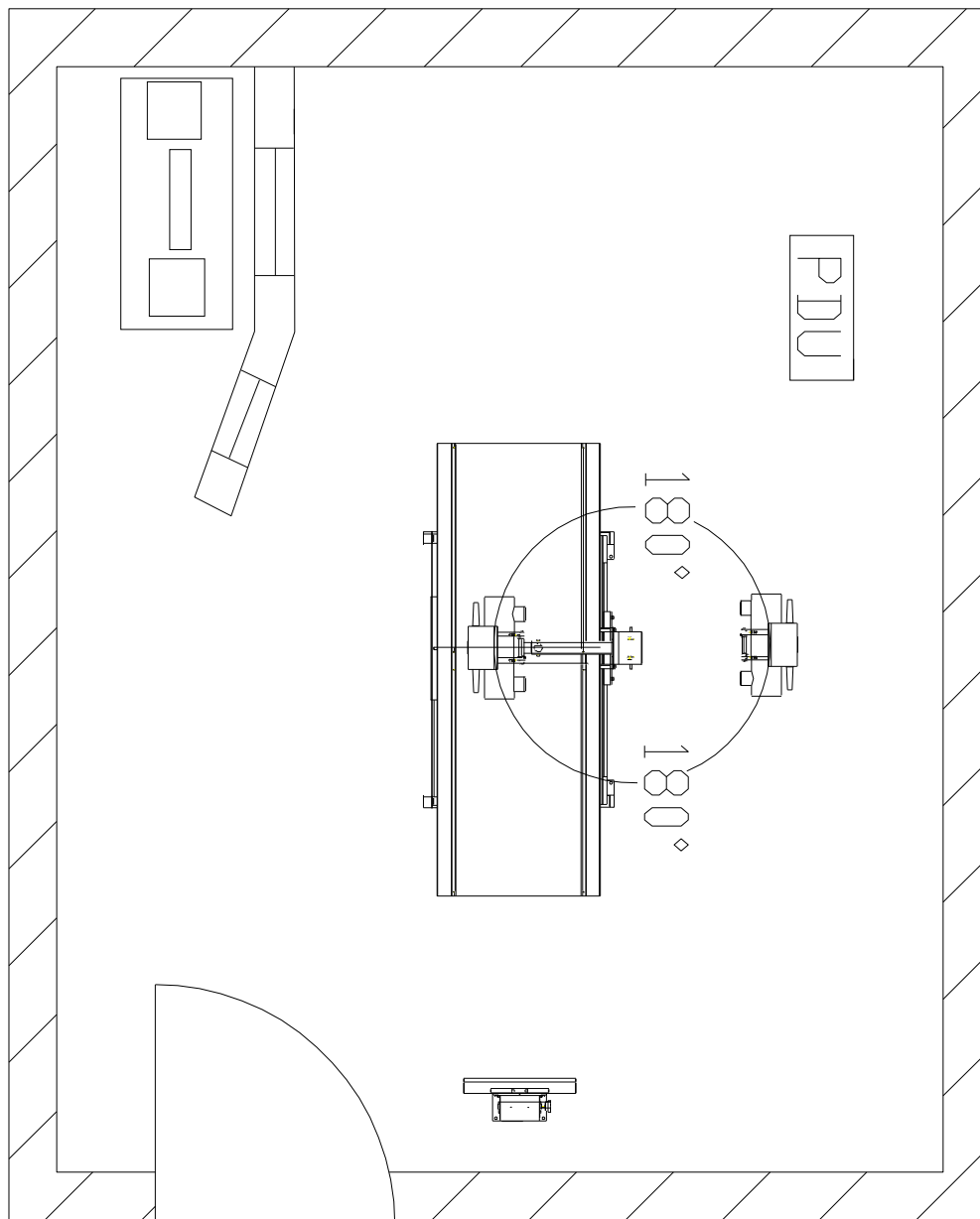

**Figure 6-1 Typical Room Layout1(Standard)**

Length(Min)		Width(Min)		Ceiling(Min)	
Recommended	Min.	Recommended	Min.	Recommended	Min.
6.0 m	5.5 m	6.0 m	5.0 m ( Standard tube stand )	3.0 m	2.5 m

Table 6-2 System Room Size Dimension

## Section 5.0 Room layout with degraded function

Note: The room layout shows the minimum room size that system needs, but customers should be required to prepare a room according with local regulatory requirements.

Note: Both two mini-size room layouts have service limitation, the tabletop can't be fully pull out after table mount..

### 5.1 Room layout without tube arm 180 degree rotation function

Notice: Must confirm with customer they accept the limitation.

#### 5.1.1 The room layout with degraded function

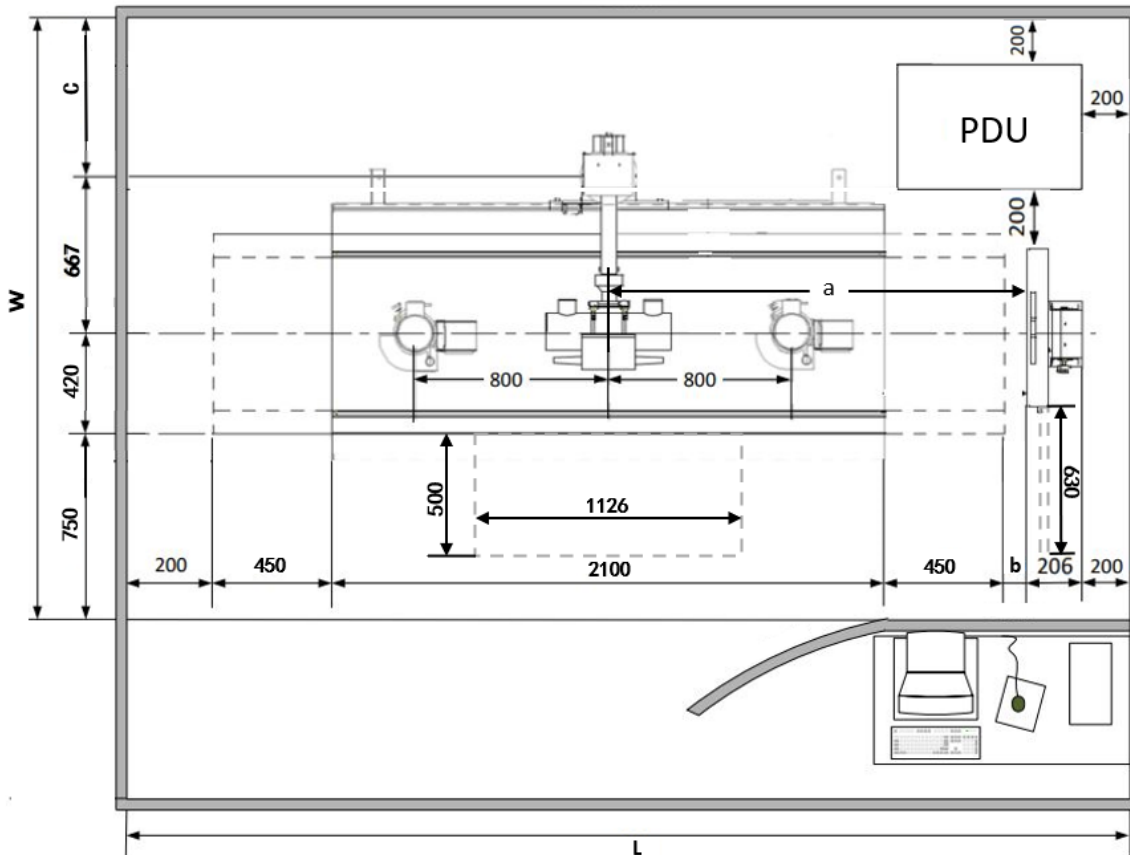

**Note:**

Both WS SID 1000 and 1800mm function:  $1600\text{mm} \leq (a) \leq 1785\text{mm}$ ;

Only WS SID 1800mm function:  $1785\text{mm} < (a) \leq 2585\text{mm}$ ;

When  $a = 1600\text{mm}$ ,  $b = 100\text{mm}$ , Room min length  $L = 3706\text{mm}$ ; When  $C = 468\text{mm}$ , Room min width  $W = 2305\text{mm}$ .

## 5.2 Room layout with tube arm 180 degree rotation function

**Notice:** Must ensure the path of customer movement table is available.

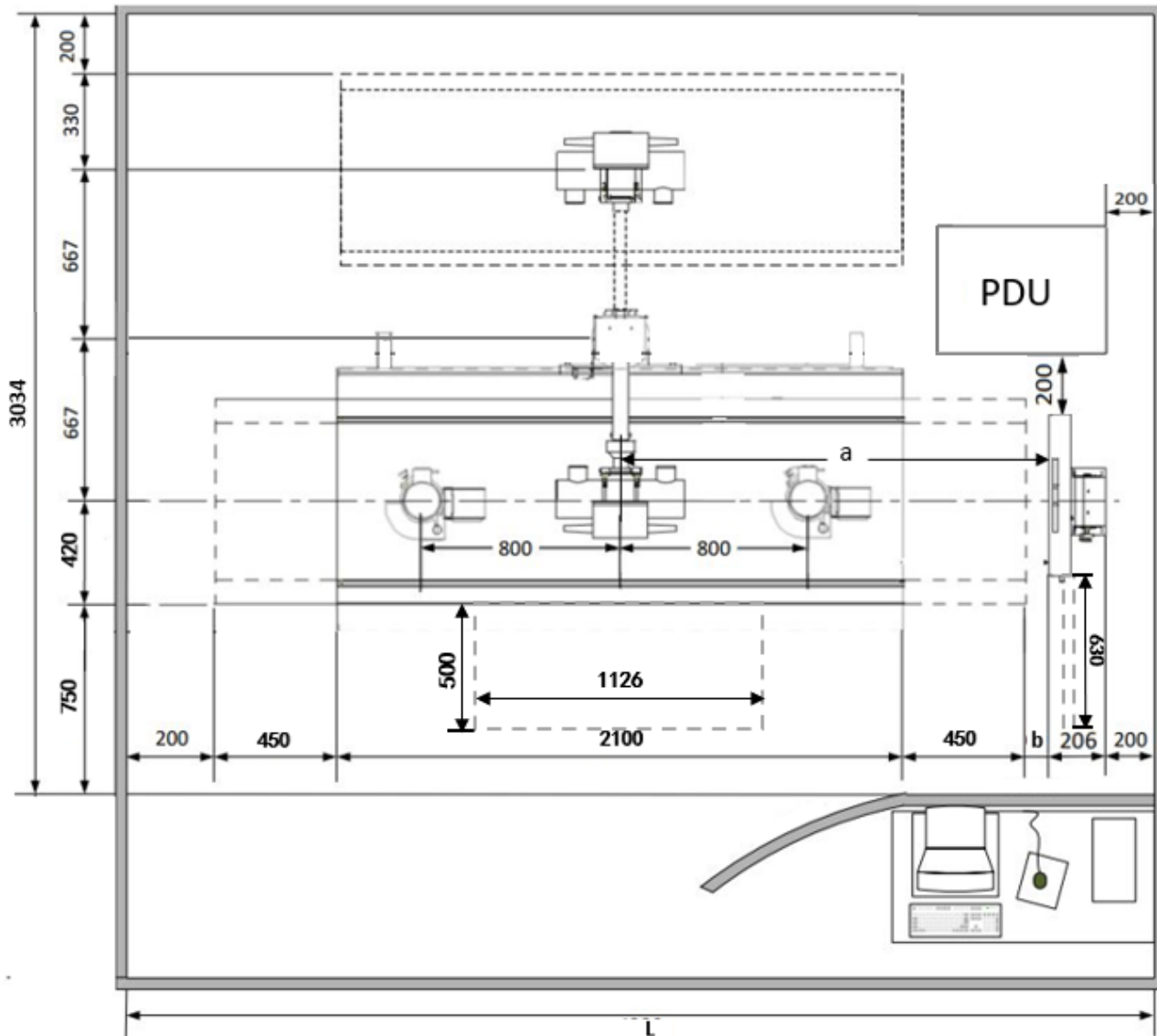

**Note:**

Both WS SID 1000 and 1800mm function:  $1600\text{mm} \leq (a) \leq 1785\text{mm}$ ;

Only WS SID 1800mm function:  $1785\text{mm} < (a) \leq 2585\text{mm}$ ;

When  $a = 1600\text{mm}$ ,  $b = 100\text{mm}$ , Room min length  $L = 3706\text{mm}$ .

# Chapter 7 - Planning Aids

## Section 1.0 Shipping Dimensions and Weights

PRODUCT OR COMPONENT	SHIPPING DATA					
	SHIPPING DIMENSIONS (APPROX.)			GROSS SHIPPING WEIGHT (approx.)	NET SHIPPING WEIGHT (approx.)	SHIPPING METHOD
	LENGTH	WIDTH	HEIGHT			
System	250	125	100	682	455	box 1# including "FIRST OPEN ME" box
Standard wall stand	200	70	40	117	78	box 2#

**Table 7-1 Shipping Data**

## Section 2.0 Installation Tools and Materials Required

### 2.1 Tools and Materials Checklist

The following tools and materials are needed for installation, but are not shipped with the product:	complete
Assorted hardware for termination of electrical connections (solder-less ring lug terminals and butt splices, AWG 2-18)	<input type="checkbox"/>
Tie wraps, electrical tape and wire markers	<input type="checkbox"/>
Tags for labelling incomplete work in accordance to OSHA and regulatory requirements	<input type="checkbox"/>
Tag and lock-out equipment	<input type="checkbox"/>
Drives, wrenches and tape (5m)	<input type="checkbox"/>
Electric and hammer drill.	<input type="checkbox"/>
Assorted sizes of tongue and groove pliers, hammers, hex wrenches (metric and SAE)	<input type="checkbox"/>
Assorted sizes of wire cutters and strippers, ratchet and standard crimpers (42,400 mm <sup>2</sup> and upwards)	<input type="checkbox"/>
Heat and electrical tape	<input type="checkbox"/>
Digital multimeter	<input type="checkbox"/>
4 ft. level (or two standard levels)	<input type="checkbox"/>

## Section 3.0 Preparing the Delivery Route

1.) Step One – Sketch out the Route

Begin preparing Route Survey by sketching the area of the hospital or clinic which will receive the equipment. Include all areas on the delivery route from outside of building to destination. See sample sketch below.

*Reference Numbers*

Numbers in circles refer to the Route Survey data. The Route Survey is a form on which site data is listed (step 2).

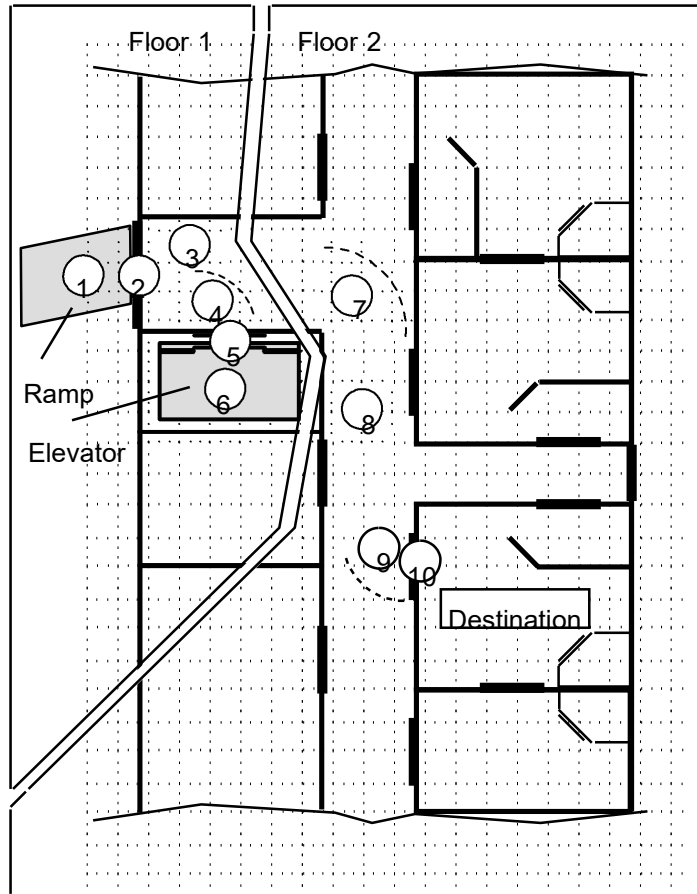

**Figure 7-1 Sample Route**

2.) Step Two – Survey the Route

Record all loading capacities, corridor widths, door openings, turning radii, flooring materials, elevator sizes, obstructions and so on for reference.

3.) Step Three – Check the Route

Verify equipment can actually be transported via the route determined in step 1.

## Section 4.0 Pre-Installation Checklist

Delivery Date: \_\_\_\_\_ Sales Person: \_\_\_\_\_  
Customer: \_\_\_\_\_ FDO No.: \_\_\_\_\_ Room # \_\_\_\_\_  
Equipment: \_\_\_\_\_

### Physical Requirements of Site

### Completed

- 1.) Room size adequate for intended equipment configuration?
- 2.) Floor is strong enough for intended equipment and mounting methods approved – seismic regulatory codes considered?
- 3.) Delivery route accommodates all intended equipment?
- 4.) Radiation physicist consulted?
- 5.) Necessary alterations made to circumvent obstructions?
- 6.) Modifications to room finished?
- 7.) Supports, platforms been provided?
- 8.) Support structures installed for floor, and wall mounted equipment?
- 9.) Has floor been modified for cable ducts?
- 10.) Electrical service in place - at the ratings specified in pre-installation documentation?
- 11.) Power available to operate power tools?
- 12.) All non-electrical lines (air, water, oxygen, vacuum) installed?

### Interconnections

### Completed

- 1.) Signal cable, power and grounding plans produced?
- 2.) Necessary interconnection hardware, such as junction boxes, conduit or raceways, and fittings provided?
- 3.) Interconnection hardware installed?
- 4.) Flexible, stranded wire provided for System input power connection?
- 5.) System “feeder” power cables pulled and sufficient length available at disconnect box for connections?
- 6.) Interconnecting cables continuity checked, and labeled?
- 7.) All high voltage cable lengths verified?
- 8.) Interface information available for equipment?

**General**

**Completed**

- 1.) Walls, and floor clear of all obstructions?
- 2.) Walls finished?
- 3.) Finished floor installed?
- 4.) Room lights installed?
- 5.) Dust-creating work completed?
- 6.) Old equipment within room removed?
- 7.) Component positions clearly marked on floor?
- 8.) Space available to store equipment?
- 9.) Lock on door, or locked room available?
- 10.) Have all fire/safety inspections for occupancy been completed?

Comments:

---

---

---

---

---

Inspection Date(s):

---

---

---

Installation Project Manager Signature

This page is intentionally left blank.

# ***Chapter 8 - System Cable Information***

## **Section 1.0 Introduction**

The following information is provided as an aid to make the physical installation of system cables easy and efficient. In the tables that follow, the physical characteristics of each cable and its associated connectors is provided. Thus making it easier to plan cable paths and clearances in advance. Physical characteristics are given for each available cable length. Review cable lengths carefully and choose lengths appropriate for your installation prior to the equipment arriving, to avoid unnecessary installation delays.

Remember, it is up to you to make sure that all cables are routed and connected in accordance with all regulatory laws that may apply.

## Section 2.0 Cable Information

### 2.1 Cable Lengths and Characteristics

Item	Cable Name	PN.	Length	Connector One End	Connector The Other End
1	Console Comm Cable	5380787-GL	12 m	Label: To PDU Four Cores, Round terminal	Label: To Console DB-15 plug
2	Console Power Cable	5380788-GL	12 m	Label: To Console J4 DB-25 plug	Branch 1 label: To Jedi Console DB-9 plug Branch 2 label: To Jedi Laptop DB-25 plug
3	Collimator and stander power cable	5388716-GL	12 m	Label: To PDU Five Cores, Round terminal	Label: To Tube Cover Including two core plug, three core plug, one core round terminal
4	Rotator cable	5582211	12.4 m	Label: To Generator One core, round terminal. Five cores and half stripping cable	Label: To Tube Terminal Six Cores, Round terminal
5	Table power cable	5388718-GL	9 m	Label: To PDU Three Cores, Round terminal	Label: To Table Three core plug
6	Table brake cable	5396297	4.5 m	Label: To XP102 Six core plug	Branch 1 label: XS104 Two core plug Branch 2 label: label: XS103 Two core plug
7	WanBo HV cable	5393036-GL	12 m	cathode and anode marks	cathode and anode marks
8	WS Power MIS cable	5860702	13 m	Label: To PDU TM1	Label: Lock button extended cable

Figure 8-2 System cable (Standard)

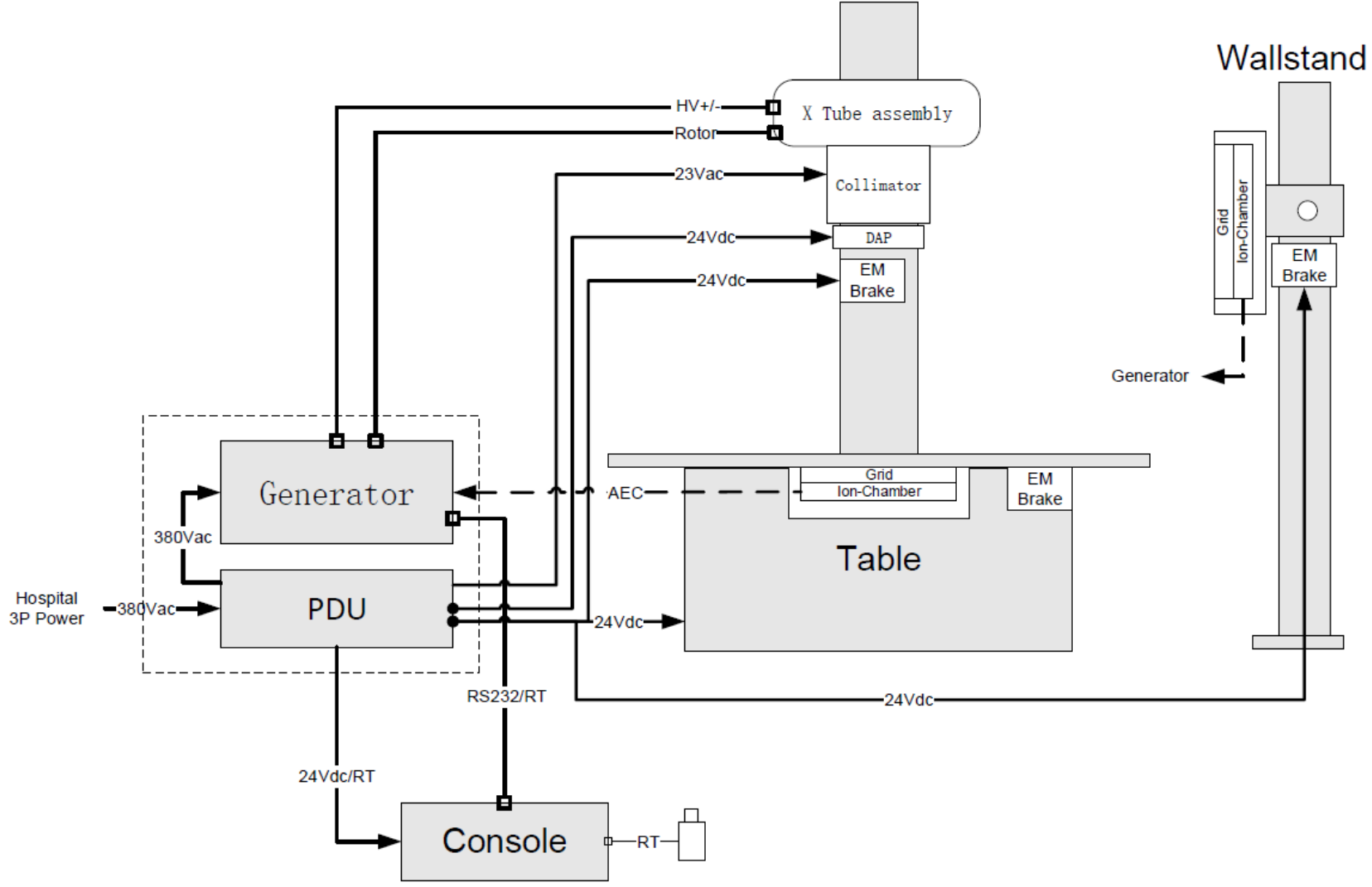

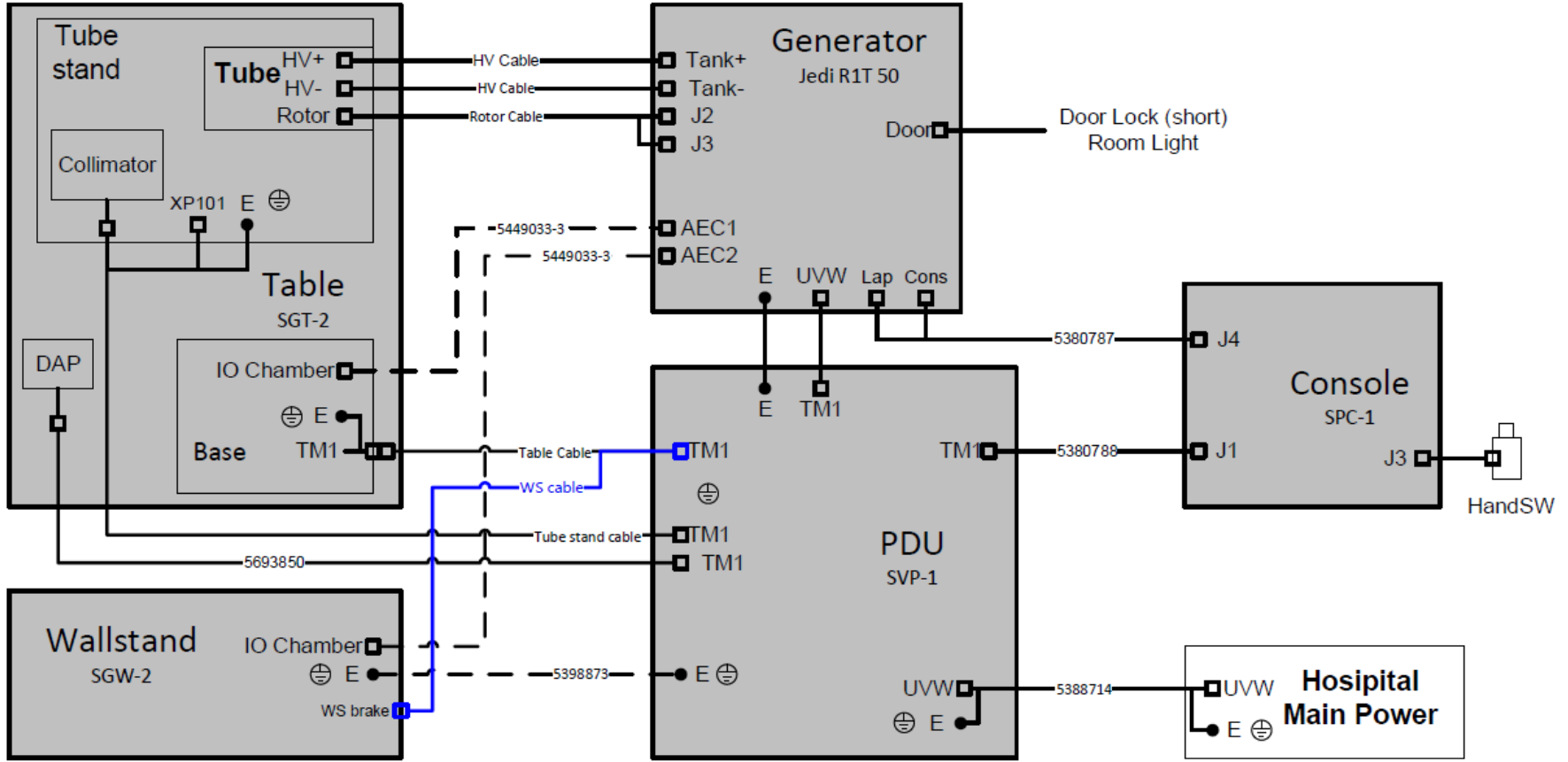

**Legend:**

AEC Option for SGT-2 & SGW-2

**Cable for SGT-2 & SGW-2**

HV cable	5122632 (12m)
	5393036 (12m)
Tube stand cable	5388716 (12m)
Rotor cable	5582211 (12m)
Table Cable	5388718 (12m)
WS Cable	5860702 (13m)

**8m Cable for SGT-1:**

HV cable	5393034
Tube stand cable	5388716-1
Rotor cable	5388717-1
Table Cable	5388718-1

---

# Appendix A - Electromagnetic Compatibility (EMC)

---

## Section 1.0 Compliance Statement

This equipment complies with IEC60601-1-2 Edition 3 (2007) EMC standard for medical devices.

This equipment generates, uses, and can radiate radio frequency energy. The equipment may cause radio frequency interference to other medical and non-medical devices and radio communications.

To provide reasonable protection against such interference, this product complies the radiated emission as per CISPR11 Group1 Class A standard limits.

However, there is no guarantee that interference will not occur in a particular installation.

If this equipment is found to cause interference (which may be determined by turning the equipment on and off), the user (or qualified service personnel) should attempt to correct the problem by one or more of the following measure(s):

- Reorient or relocate the affected device(s)
- Increase the separation between the equipment and the affected device (see recommended separation distances)
- Power the equipment from a source different from that of the affected device
- Consult the point of purchase or service representative for further suggestions

Use of accessories, transducers, cables and other parts other than those specified by the manufacturer of this equipment may result in increased emissions or decreased immunity of the equipment.

The manufacturer is not responsible for any interference caused by using other than recommended interconnect cables or by unauthorized changes or modifications to this equipment. Unauthorized changes or modifications could void the users' authority to operate the equipment.

All interconnect cables to peripheral devices must be shielded and properly grounded, except when technologically prohibited. Use of cables not properly shielded and grounded may result in the equipment causing radio frequency interference.

The XR 6000 is predominantly intended for use in non-domestic environments, and not directly connected to the Public Mains Network that supplies buildings used for domestic purposes.

The compatible accessories must be used within the recommended operating conditions outlined in the operation manuals. In addition to calibration and warm-up, other devices must be reset before and after use to ensure accurate dose measurements. Sustained exposure to electromagnetic fields (exceeding the test conditions) may cause false measurements. Failure to follow the recommended use may cause false measurements.

The magnetic field environment from a MRI device located nearby is a risk of interference.

All of the above are required to achieve the Electromagnetic Compatibility for a typical installation of the XR 6000. Further detailed data & requirements are described in the Use Recommendations and Installation Recommendations sections.

## Section 2.0 Compatibility Tables

This equipment complies with IEC60601-1-2 Edition 3 (2007) EMC standard for medical devices.

The XR 6000 is suitable to be used in an electromagnetic environment, as per the limits & recommendations described in the tables hereafter:

- Emission Compliance level & limits (Table 1).
- Immunity Compliance level & recommendations to maintain equipment clinical utility (see Table 2 and Table 3).

Note: This system complies with above mentioned EMC standard when used with supplied cables. If different cable lengths are required, contact a qualified service representative for advice.

### 2.1 Electromagnetic Emission

Guidance and manufacturer’s declaration – Electromagnetic Emissions

The XR 6000 is intended for use in the electromagnetic environment specified below. The customer or the user of the XR 6000 should assure that it is used in such an environment.

Emissions Test	Compliance	Electromagnetic Environment Guidance
RF emission, CISPR 11	Group 1	The XR 6000 uses RF energy only for its internal function. Therefore, its RF emissions are very low and are not likely to cause any interference in nearby electronic equipment.
RF emissions, CISPR 11	Class A	The XR 6000 is suitable for use in non-domestic environments, and not directly connected to the Public Mains Network. The XR 6000 is predominantly intended for use (e.g. in hospitals) with an appropriate power supply (see operation manual) and the recommended shielding for portable use.
Harmonic emissions, IEC 61000-3-2	Not applicable	
Voltage fluctuations, flicker emissions, IEC 61000-3-3	Not applicable	

**Table 1 R 6000 Electromagnetic Emission**

## 2.2 Electromagnetic Immunity

Guidance and Manufacturer's declaration – electromagnetic immunity.

The XR 6000 is intended for use in the electromagnetic environment specified below. The customer or the user of the XR 6000 should assure that it is used in such an environment.

Immunity Test	IEC 60601-1-2 Test Level	Compliance Level	Electromagnetic Environment Guidance
Electrostatic discharge (ESD), IEC 61000-4-2	+/- 6 kV contact. +/- 8 kV air.	+/- 6 kV contact. +/- 8 kV air.	Floors should be wood, concrete, or ceramic tile. If floors are covered with synthetic material, the relative humidity should be at least 30%.
Electrical fast transient/burst, EC 61000-4-4	+/- 2 kV for power supply lines. +/- 1 kV for input/output lines.	+/- 2 kV for power supply lines. +/- 1 kV for input/output lines.	Mains power quality should be that of a typical commercial or hospital environment
Surge, IEC 61000-4-5	+/- 1 kV differential mode. +/- 2 kV common mode.	+/- 1 kV differential mode. +/- 2 kV common mode.	Mains power quality should be that of a typical commercial or hospital environment.
Voltage dips, short interruptions and voltage variations on power supply input lines, IEC 61000-4-11	< 5% $U_T$ , (> 95% dip in $U_T$ ) for 0.5 cycle. 40% $U_T$ (60% dip in $U_T$ ) for 5 cycles. 70% $U_T$ (30% dip in $U_T$ ) for 25 cycles. < 5% $U_T$ , (> 95% dip in $U_T$ ) for 5 sec.	0% $U_T$ for 5 sec.	Mains power quality should be that of a typical commercial or hospital environment. If the user of the XR 6000 requires continued operation during power mains interruptions, it is recommended that the XR 6000 be powered from an uninterruptible power supply or a battery.
Power frequency (50/60 Hz) magnetic field, IEC 61000-4-8	3 A/m	3 A/m	Power frequency magnetic fields should be at levels characteristic of a typical location in a typical commercial or hospital environment.

Note: These are guidelines. Actual conditions may vary.

**Table 2 XR 6000 Electromagnetic Immunity**

Guidance and Manufacturer's declaration - electromagnetic immunity. The XR 6000 is suitable for use in the specified electromagnetic environment. The customer or the user of the XR 6000 should assure that it is used in an electromagnetic environment as described below.

Immunity Test	IEC 60601-1-2 Test Level	Test Compliance Level	Electromagnetic Environment Guidance
Conducted RF IEC 61000-4-6	3 Vrms, 150 kHz to 80 MHz	V1 = 3Vrms	Portable and mobile RF communications equipment should be used no closer to any part of the XR 6000, including cables, than the recommended separation distance calculated from the equation appropriate for the frequency of the transmitter. <b>Recommended Separation Distance</b>  $d = 1.2 \sqrt{P}$  $d = 1.2 \sqrt{P}$ 80 MHz to 800 MHz  $d = 2.3 \sqrt{P}$ 800 MHz to 2.5 GHz  where, P is the maximum output power rating of the transmitter in watts (W) according to the transmitter manufacturer and d is the recommended separation distance in metres (m).  Field strengths from fixed RF transmitters, as determined by an electromagnetic site survey <sup>a</sup> , should be less than the compliance level in each frequency range <sup>b</sup> .  Interference may occur in the vicinity of equipment marked with the following symbol:  
Radiated RF IEC 61000-4-3	3 V/m, 80 MHz to 2.5 GHz	E1 = 3V/m	

<sup>a</sup> Field strengths from fixed transmitters, such as base stations for radio (cellular/cordless) telephones and land mobile radios, amateur radio, AM and FM radio broadcast, and TV broadcast cannot be predicted theoretically with accuracy. To assess the electromagnetic environment due to fixed RF transmitters, an electromagnetic site survey should be considered. If the measured field strength in the location in which the XR 6000 is used exceeds the applicable RF compliance level above, the XR 6000 should be observed to verify normal operation. If abnormal performance is observed, additional measures may be necessary, such as re-orienting or relocating the XR 6000.

<sup>b</sup> Over the frequency range 150 kHz to 80 MHz, field strengths should be less than [V1] V/m.

These guidelines may not apply in all situations. Electromagnetic propagation is affected by absorption and reflection from structures, objects, and people.

**Table 3 XR 6000 Electromagnetic Immunity (Continued)**

Recommended separation distances between portable and mobile RF communications equipment and the XR 6000			
The XR 6000 is intended for use in an electromagnetic environment in which radiated RF disturbances are controlled. The customer or the user of the XR 6000 can help prevent electromagnetic interference by maintaining a minimum distance between portable and mobile RF communications equipment (transmitters) and the XR 6000 as recommended below, according to the maximum output power of the communications equipment.			
Rated Maximum Output Power (P) of Transmitter Watts (W)	Separation distance according to frequency of transmitter		
	150 kHz to 80 MHz  $d = 1.2 \sqrt{P}$  Separation Distance meters	80 MHz to 800 MHz  $d = 1.2 \sqrt{P}$  Separation Distance meters	800 MHz to 2.5 GHz  $d = 2.3 \sqrt{P}$  Separation Distance meters
0.01 (10 mW)	0.12	0.12	0.23
0.1 (100 mW)	0.38	0.38	0.74
1	1.2	1.2	2.3
10	3.8	3.8	7.3
100	12	12	23
For transmitters rated at a maximum output power not listed above, the separation distance can be estimated using the equation in the corresponding column, where P is the maximum output power rating of the transmitter in watts (W) according to the transmitter manufacturer. V1 and V2 are the COMPLIANCE LEVELS for the IEC 61000-4-6 test and E1 is the COMPLIANCE LEVEL for the IEC 61000-4-3 test. V1 and V2 are in V and E1 is in V/m.			
NOTE 1: At 80 MHz and 800 MHz, the separation distance for the higher frequency range applies.			
NOTE 2: These guidelines may not apply in all situations. Electromagnetic propagation is affected by absorption and reflection from structures, objects, and people.			

**Table 4 Recommended Separation Distances**

## Section 3.0 Use Recommendations

This product complies with IEC 60601-1-2 Edition 3 (2007) EMC standard for medical devices and with radio frequency emission requirements per CISPR11 Group1 Class A standard limits. The XR 6000 is predominantly intended for use in hospitals.

Do not use devices which intentionally transmit RF Signals (Cellular Phones, Transceivers, or Radio Controlled Products) in the vicinity of this equipment as it may cause performance outside the published specifications. Keep the power to these types of devices turned off when near this equipment.

Adhering to the distance separation recommended in Table 4, between 150 kHz & 2.5 GHz, will reduce disturbances recorded at the image level but may not eliminate all disturbances. However, when installed and operated as specified herein, the system will maintain its essential performance by continuing to safely acquire controlled radiological X-ray exposures in a mobile radiography environment.

For example, a 1W mobile phone (800 MHz to 2.5 GHz carrier frequency) shall be put 2.3 meters apart from the XR 6000 (in order to avoid image interference risks).

The use of accessories, transducers, and cables other than those specified may result in degraded ELECTROMAGNETIC COMPATIBILITY of the XR 6000.

---

The medical staff in charge of this equipment is required to instruct technicians, patients, and other people who may be around this equipment to comply fully with the above equipment requirements.

## Section 4.0 Installation Recommendations

This system complies with above mentioned EMC standard when used with supplied cables.  
In order to minimize interference risks, the following requirements shall apply.

### 4.1 Cable Shielding & Grounding

All interconnect cables to peripheral devices must be shielded and properly grounded. Use of cables not properly shielded and grounded may result in the equipment causing radio frequency interference.

### 4.2 Subsystem & Accessories Power Supply Distribution

All components, accessories subsystems, systems which are electrically connected to the XR 6000, must have all AC power supplied by the same power distribution panel & line.

### 4.3 Stacked Components & Equipment

The XR 6000 should not be used adjacent to or stacked with other equipment; if adjacent or stacked use is necessary, the XR 6000 should be tested and verified in order to ensure normal operation in the configuration in which it will be used. Consult qualified personnel regarding device/system configurations.

### 4.4 Low Frequency Magnetic Field

Not applicable.

### 4.5 Electrostatic Discharge Environment & Recommendations

In order to reduce electrostatic discharge interference, install a charge dissipative floor material to avoid electrostatic charge buildup.

The relative humidity shall be at least 30 percent.

The dissipative material shall be connected to the system ground reference, if applicable.

## ***EAppendix B - Revision History***

<b>Revision</b>	<b>Date</b>	<b>Reason for change</b>
1	2021.08.06	First Release
2	2022.03.31	Update Section 5 of Chapter 6 per SN2356185.
3	2022.08.17	Delete 32kW info in 1.2.3 Recommended Wall "Circuit-Breaker" Ratings.

***GE HEALTHCARE***

***NO.1, YONGCHANG NORTH ROAD  
ECONOMIC & TECHNOLOGICAL DEVELOPMENT ZONE***

***FAX: 86-10-67881850***

***TELE: 86-10-58068888***

***BEIJING, P. R. CHINA 100176***