



SIGNA™ Sprint

Preinstallation Manual

5982837-8EN
Revision 2

Contents

1 Introduction	9
1.1 Preinstall Manual Introduction.....	9
1.1.1 Document Purpose.....	9
1.1.2 Intended User.....	9
1.1.3 Who Should Read This Manual.....	10
1.1.4 Related Publications.....	12
1.1.5 Document Overview.....	12
1.2 Symbols Key.....	13
2 General System Level	14
2.1 Safety Considerations.....	14
2.2 System Level Requirements for Installing into Existing MR Suite.....	14
2.3 System components.....	16
2.3.1 Magnet Room.....	16
2.3.2 Equipment Room.....	16
2.3.3 Control Room.....	16
2.3.4 Accessories.....	16
2.3.5 System Overview.....	17
2.4 MR Suite Minimum Room Size Requirements.....	18
2.5 MR System Seismic Requirements.....	21
2.6 Structure-borne Vibration Control Specifications.....	22
2.7 MR Suite Magnetic Field Specifications.....	24
2.7.1 Magnetic Fringe Field.....	24
2.7.2 Interference from Changing Magnetic Fields.....	28
2.7.3 Electrical Current.....	31
2.7.4 Non-MR System Equipment Sensitivity to Magnetic Fields.....	32
2.8 Multiple MR System Requirements.....	33
2.8.1 Multiple Magnets.....	33
2.8.2 Shared Equipment Rooms.....	33
2.9 MR Suite Temperature and Humidity.....	35
2.9.1 Temperature and Humidity Requirements.....	35
2.9.2 Equipment Heat Output Specifications.....	36
2.10 Facility Coolant Requirements.....	37
2.10.1 Integrated Cooling Cabinet (ICC) Coolant Requirements.....	37
2.10.2 Requirements for Emergency Backup Facility Coolant (Optional).....	41
2.11 MR Suite Electrical Requirements.....	44
2.11.1 General Electrical Requirements.....	44
2.11.2 GE HealthCare Supplied Main Disconnect Panel (MDP) Specifications for M7100MD.....	46
2.11.3 Customer-supplied Main Disconnect Panel (MDP) Requirements (exempt countries only*).....	49
2.11.4 Emergency Power Backup Specifications (Optional).....	52
2.12 MR System Shipping and Receiving.....	53

2.12.1 Receiving Requirements	53
2.12.2 Facility Delivery Route Requirements	53
2.12.3 MR System Component Shipping Specifications	54
2.12.4 Temperature and Humidity Storage Requirements	57
3 Magnet Room	58
3.1 Magnet Room Introduction.....	58
3.2 Magnet Room Structural Requirements.....	60
3.2.1 Overview.....	60
3.2.2 Environmental Steel Limits	60
3.2.3 Vibration Requirements	61
3.3 Magnetic Shielded Room Requirements.....	62
3.4 Penetration Panel Wall Opening Requirements	63
3.5 Finished Room Requirements	65
3.5.1 Ferrous Materials in the Magnet Room	65
3.5.2 Walls.....	65
3.5.3 Magnet Preinstallation Markings.....	65
3.5.4 Penetration Panel Closet	69
3.5.5 Penetration Panel Closet Specifications	70
3.5.6 Doors, Magnet Access Openings, and Patient Viewing Windows.....	71
3.5.7 Finished Ceiling.....	71
3.5.8 Magnet Room Floors	72
3.5.9 Storage Cabinets	75
3.6 Magnet Room Equipment Specifications.....	76
3.6.1 Magnet (MAG) Assembly Specifications	76
3.6.2 Patient Table (PT) Specifications.....	76
3.6.3 Magnet Rundown Unit (MRU) Specifications and Requirements	77
3.6.4 Oxygen Monitor Option Sensor Specifications	78
3.7 Magnet Room Lighting Requirements.....	79
4 Equipment Room	80
4.1 Equipment Room Overview	80
4.2 Main Disconnect Panel (MDP) Requirements and Specifications	82
4.2.1 Requirements	82
4.2.2 Specifications	82
4.3 Integrated System Cabinet (ISC) Specifications	84
4.4 Integrated Cooling Cabinet (ICC) Specifications.....	88
4.5 Penetration Panel Specifications.....	90
4.6 Magnet Monitor (MON) Requirements and Specifications	92
4.6.1 Requirements	92
4.6.2 Specifications	92
4.7 Magnetic Resonance Elastography (MRE) Specifications (Optional Equipment).....	94
4.7.1 Requirements	94

4.7.2 Specifications	94
5 Control Room	96
5.1 Operator Workspace Equipment Specifications	96
5.1.1 Operator Workspace Assembly	96
5.1.2 Operator Workspace (OW) (Optional Equipment)	97
5.1.3 Global Operator Cabinet (GOC)	98
5.1.4 Host Display.....	99
5.1.5 Host Keyboard.....	99
5.1.6 Pneumatic Patient Alert.....	100
5.2 Oxygen Monitor (OXY) Specifications (Optional Equipment)	101
5.3 Physiological Acquisition Transceiver (PAT) Charging Station Specification (Optional Equipment)	102
6 Digital Service and Connectivity Requirements	103
6.1 InSite RSvP (Remote Service Platform) Requirements.....	103
6.1.1 InSite RSvP Connectivity Requirements	103
7 MR System Interconnects	104
7.1 MR System Interconnects Specifications	104
7.1.1 Component Designator Definitions	104
7.1.2 Available Cable Lengths.....	104
7.1.3 BrainWave Option	108
7.1.4 Magnetic Resonance Elastography (MRE) Option	108
7.1.5 Storage Requirements for Excess Gradient Cable	108
7.2 MR System Interconnects Routing Requirements	112
7.2.1 General Requirements	112
7.2.2 Magnet Room Requirements	113
7.2.3 Recommended Cable Groupings	114
7.2.4 Cable Tray Requirements and Examples.....	114
7.2.5 Penetration Panel Closet Requirements.....	117
7.2.6 Equipment Room Requirements.....	118
7.3 Facility-Supplied System Interconnects Specifications	119
8 Appendix.....	122
8.1 Glossary	122
8.2 MR Site Vibration Test Guidelines.....	124
8.2.1 Test Measurements	124
8.2.2 Equipment (Spectral Analyzer) Set-Up	124
8.2.3 Data Collection.....	125
8.2.3.1 Ambient Baseline Condition	125
8.2.3.2 Normal Condition	125
8.2.4 Presentation/Interpretation of Results	125
8.3 Sample Calculation AC Power Equipment Minimum Distance	129
8.4 Selecting Anchor Size.....	131
8.5 Sample control schematic for customer-supplied MDP.....	132

Revision History..... 134

Language Policy

DOC0371395 - Global Language Procedure

ПРЕДУПРЕЖ ДЕНИЕ (BG)	Това ръководство е налично само на китайски (ZH-CN), английски, френски, немски, японски, корейски, полски, португалски (PT-BR), руски, испански и виетнамски. Ако доставчикът на услуги на даден клиент изисква език, който е различен от тези езици, отговорност на клиента е да предостави преводачески услуги.
警告 (ZH-CN)	本手册仅提供中文 (ZH-CN)、英文、法语、德语、意大利语、日语、韩语、波兰语、葡萄牙语 (PT-BR)、俄语、西班牙语和越南语版本。如果客户的服务提供商需要其他语言，则客户有责任提供翻译服务。
警告 (ZH-HK)	本手冊僅提供中文 (ZH-CN)、英文、法文、德文、意大利文、日文、韓文、波蘭文、葡萄牙文 (PT-BR)、俄文、西班牙文及越南文版本。如客戶的服務供應商需要這些語言以外的版本，則相關客戶有責任提供有關的翻譯服務。
警告 (ZH-TW)	此手冊僅提供中文 (ZH-CN)、英文、法文、德文、義大利文、日文、韓文、波蘭文、葡萄牙文 (PT-BR)、俄文、西班牙文和越南文版本。假如客戶的服務提供者所需語言版本不在所列語言之中，客戶需自行負責提供翻譯服務。
UPOZORENJE (HR)	Ovaj je priručnik dostupan samo na kineskom (ZH-CN), engleskom, francuskom, njemačkom, talijanskom, japanskom, korejskom, poljskom, portugalskom (PT-BR), ruskom, španjolskom i vijetnamskom jeziku. Ako klijentov serviser zahtijeva jezik koji nije jedan od tih jezika, odgovornost je klijenta pružiti uslugu prevođenja.
VÝSTRAHA (CS)	Tato příručka je k dispozici pouze v čínštině (ZH-CN), angličtině, francouzštině, němčině, italštině, japonštině, korejštině, polštině, portugalštině (PT-BR), ruštině, španělštině a vietnamštině. Pokud poskytovatel služeb zákazníka vyžaduje jiný jazyk než tyto jazyky, je odpovědností zákazníka poskytovat překladatelské služby.
ADVARSEL (DA)	Denne vejledning findes kun på kinesisk (ZH-CN), engelsk, fransk, tysk, italiensk, japansk, koreansk, polsk, portugisisk (PT-BR), russisk, spansk og vietnamesisk. Hvis en kundes tjenesteudbyder kræver et andet sprog end disse sprog, er det kundens ansvar at levere oversættelsestjenester.
WAARSCHUWING (NL)	Deze handleiding is alleen beschikbaar in het Chinees (ZH-CN), Engels, Frans, Duits, Italiaans, Japans, Koreaans, Pools, Portugees (PT-BR), Russisch, Spaans en Vietnamees. Als de serviceprovider van een klant een andere taal dan deze talen vereist, is het de verantwoordelijkheid van de klant om vertaalservices te leveren.
WARNING (EN)	This manual is available in Chinese (ZH-CN), English, French, German, Italian, Japanese, Korean, Polish, Portuguese (PT-BR), Russian, Spanish, and Vietnamese only. If a customer's service provider requires a language other than these languages, it is the customer's responsibility to provide translation services.
HOIATUS (ET)	See juhend on saadaval ainult hiina (ZH-CN), inglise, prantsuse, saksa, itaalia, jaapani, korea, poola, portugali (PT-BR), vene, hispaania ja vietnami keeles. Kui kliendi teenusepakkujal on vaja juhendit mõnes muus keeles, on tõlketeenuste osutamine kliendi kohustus.
VAROITUS (FI)	Tämä opas on saatavilla vain kiinaksi (ZH-CN), englanniksi, ranskaksi, saksaksi, italiaksi, japaniksi, koreaksi, puolaksi, portugaliksi (PT-BR), venäjäksi, espanjaksi ja vietnamiksi. Jos asiakkaan palveluntarjoaja edellyttää muuta kuin näitä kieliä, käänöspalveluiden tarjoaminen on asiakkaan vastuulla.
ATTENTION (FR)	Ce manuel est disponible uniquement en allemand, anglais, chinois (ZH-CN), coréen, espagnol, français, italien, japonais, polonais, portugais (PT-BR), russe et vietnamien. Si le prestataire de services d'un client nécessite que le manuel soit rédigé dans une autre langue que celles mentionnées ci-dessus, il incombe au client de le faire traduire.
WARNUNG (DE)	Dieses Handbuch ist nur auf Chinesisch (ZH-CN), Englisch, Französisch, Deutsch, Italienisch, Japanisch, Koreanisch, Polnisch, Portugiesisch (PT-BR), Russisch, Spanisch und Vietnamesisch verfügbar. Wenn ein Dienstleister des Kunden dieses in einer anderen Sprache als die genannten benötigt, liegt es in der Verantwortung des Kunden, Übersetzungsdienstleistungen zu erbringen.

ΠΡΟΕΙΔΟΠΟΙΗΣΗ (EL)	Αυτό το εγχειρίδιο είναι διαθέσιμο μόνο σε Κινεζικά (ZH-CN), Αγγλικά, Γαλλικά, Γερμανικά, Ιταλικά, Ιαπωνικά, Κορεατικά, Πολωνικά, Πορτογαλικά (PT-BR), Ρωσικά, Ισπανικά και Βιετναμέζικα. Εάν ο πάροχος υπηρεσιών ενός πελάτη απαιτεί γλώσσα που δεν συμπεριλαμβάνεται σε αυτές τις γλώσσες, αποτελεί ευθύνη του πελάτη να παρέχει υπηρεσίες μετάφρασης.
FIGYELMEZTETÉS (HU)	Ez a kézikönyv az alábbi nyelveken érhető el: angol, francia, japán, kínai (ZH-CN), koreai, lengyel, német, olasz, orosz, portugál (PT-BR), spanyol és vietnámi. Ha az ügyfél szolgáltatója ezektől eltérő nyelvű kézikönyvet szeretne, akkor az ügyfél feladata, hogy gondoskodik a megfelelő fordításról.
AÐVÖRUN (IS)	Þessi handbók er aðeins fánleg á kínversku (ZH-CN), ensku, frönsku, þýsku, ítölsku, japönsku, kóresku, pólsku, portúgölsku (PT-BR), rússnesku, spænsku og víetnömsku. Ef þjónustuaðili viðskiptavinar þarfnast annars tungumáls en þessara tungumála er það á ábyrgð viðskiptavinarins að veita þýðingarþjónustu.
AVVERTENZA (IT)	Questo manuale è disponibile solo in lingua cinese (ZH-CN), inglese, francese, tedesco, italiano, giapponese, coreano, polacco, portoghese (PT-BR), russo, spagnolo e vietnamita. Qualora un fornitore di servizi del cliente richieda una lingua diversa dall'inglese, sarà responsabilità del cliente fornire il servizio di traduzione corrispondente.
警告 (JA)	このマニュアルは、中国語 (ZH-CN)、英語、フランス語、ドイツ語、イタリア語、日本語、韓国語、ポーランド語、ポルトガル語 (PT-BR)、ロシア語、スペイン語、およびベトナム語のみで提供されています。お客様のサービスプロバイダがこれらの言語以外の言語を必要とする場合は、お客様の責任において翻訳サービスを提供してください。
경고 (KO)	이 설명서는 중국어(중국어-중국), 영어, 프랑스어, 독일어, 이탈리아어, 일본어, 한국어, 폴란드어, 포르투갈어(포르투갈어-브라질), 러시아어, 스페인어, 베트남어로만 제공됩니다. 고객의 서비스 제공자가 이 언어를 제외한 다른 언어를 요구하는 경우, 번역 서비스를 제공하는 것은 고객의 책임입니다.
BRĪDINĀJUMS (LV)	Šī rokasgrāmata ir pieejama tikai ķīniešu (ZH-CN), angļu, franču, vācu, itāliešu, japāņu, korejiešu, poļu, portugāļu (PT-BR), krievu, spāņu un vjetnamiešu valodā. Ja klientu apkalpošanas speciālistam ir nepieciešama cita valoda, kas atšķiras no šeit norādītajām, klienta pienākums ir nodrošināt tulkotājas pakalpojumu.
ĮSPĖJIMAS (LT)	Šis vadovas pateikiamas tik kinų (ZH-CN), anglų, prancūzų, vokiečių, italų, japonų, korėjiečių, lenkų, portugalų (PT-BR), rusų, ispanų ir vietnamiečių kalbomis. Jei klientų paslaugų teikėjui reikalinga kita nei šios kalba, už vertimo paslaugų suteikimą atsako klientas.
ADVARSEL (NO)	Denne håndboken er bare tilgjengelig på kinesisk (ZH-CN), engelsk, fransk, tysk, italiensk, japansk, koreansk, polsk, portugisisk (PT-BR), russisk, spansk og vietnamesisk. Hvis en kundes tjenesteleverandør krever et annet språk, er det kundens ansvar å levere en oversettelsestjeneste.
OSTRZEŻENIE (PL)	Niniejsza instrukcja jest dostępna wyłącznie w języku chińskim (ZH-CN), angielskim, francuskim, niemieckim, włoskim, japońskim, koreańskim, polskim, portugalskim (PT-BR), rosyjskim, hiszpańskim i wietnamskim. Jeśli usługodawca klienta wymaga języka, który nie został wymieniony powyżej, obowiązkiem klienta jest zapewnienie usług tłumaczeniowych.
ATENÇÃO (PT-BR)	Este manual está disponível somente em chinês (ZH-CN), inglês, francês, alemão, italiano, japonês, coreano, polonês, português (PT-BR), russo, espanhol e vietnamita. Se o prestador de serviços de um cliente necessitar de um idioma diferente dos mencionados, o fornecimento dos serviços de tradução é de responsabilidade do cliente.
ATENÇÃO (PT-PT)	Este manual está disponível apenas em alemão, chinês (ZH-CN), coreano, espanhol, francês, inglês, italiano, japonês, polaco, português (PT-BR), russo e vietnamita. Se o fornecedor de serviços de um cliente necessitar de um idioma diferente dos listados aqui, é da responsabilidade do cliente assegurar os serviços de tradução.
ATENȚIE (RO)	Acest manual este disponibil numai în limbile chineză (ZH-CN), engleză, franceză, germană, italiană, japoneză, coreeană, poloneză, portugheză (PT-BR), rusă, spaniolă și vietnameză. Dacă furnizorul de servicii al unui client solicită o limbă diferită față de aceste limbi, este responsabilitatea clientului să furnizeze servicii de traducere.

ОСТОРОЖНО! (RU)	Настоящее руководство доступно только на китайском (ZH-CN), английском, французском, немецком, итальянском, японском, корейском, польском, португальском (PT-BR), русском, испанском и вьетнамском языках. Если поставщику услуг заказчика требуется руководство на каком-либо другом языке, перевод руководства на необходимый язык осуществляется стороной заказчика.
UPOZORENJE (SR)	Ovaj priručnik dostupan je samo na kineskom (ZH-CN), engleskom, francuskom, nemačkom, italijanskom, japanskom, korejskom, poljskom, portugalskom (PT-BR), ruskom, španskom i vijetnamskom jeziku. Ako korisnik kao pružalac usluge zahteva neki drugi jezik od navedenih, njegova je dužnost da obezbedi prevod.
UPOZORNENIE (SK)	Táto príručka je dostupná len v nasledovných jazykoch: čínština (ZH-CN), angličtina, francúzština, nemčina, taliančina, japončina, kórejščina, poľština, portugalčina (PT-BR), ruština, španielčina a vietnamčina. Ak poskytovateľ služieb daného zákazníka požaduje iný ako tieto jazyky, za poskytnutie prekladateľských služieb zodpovedá zákazník.
ATENCIÓN (ES)	Este manual está disponible solo en chino (ZH-CN), inglés, francés, alemán, italiano, japonés, coreano, polaco, portugués (PT-BR), ruso, español y vietnamita. Si el proveedor de servicios de un cliente requiere un idioma distinto de estos idiomas, es responsabilidad del cliente proporcionar los servicios de traducción.
VARNING (SV)	Den här manualen finns endast tillgänglig på kinesiska (ZH-CN), engelska, franska, tyska, italienska, japanska, koreanska, polska, portugisiska (PT-BR), ryska, spanska och vietnamesiska. Om en kunds tjänsteleverantör behöver ett annat språk än dessa är det kundens ansvar att ordna med översättningstjänster.
OPOZORILO (SL)	Ta priročnik je na voljo v kitajščini (ZH-CN), angleščini, francoščini, nemščini, italijanščini, japonščini, korejščini, poljščini, portugalščini (PT-BR), ruščini, španščini in vietnamščini. Če kupčev ponudnik storitev potrebuje drug jezik, mora za prevod poskrbeti kupec.
DİKKAT (TR)	Bu kılavuz yalnızca Çince (ZH-CN), İngilizce, Fransızca, Almanca, İtalyanca, Japonca, Korece, Lehçe, Portekizce (PT-BR), Rusça, İspanyolca ve Vietnamca dillerinde mevcuttur. Müşteri servis sağlayıcısı bu dillerden başka bir dil talep ederse çeviri hizmeti sağlamak müşterinin sorumluluğundadır.
ЗАСТЕРЕЖЕННЯ (UK)	Цей посібник доступний лише китайською (ZH-CN), англійською, французькою, німецькою, італійською, японською, корейською, польською, португальською (PT-BR), російською, іспанською та в'єтнамською мовами. Якщо постачальник послуг замовника використовує мову, яку не вказано у цьому переліку, послуги з перекладу має забезпечити замовник.

1 Introduction

1.1 Preinstall Manual Introduction



(Applies to all subsections within this section)

1.1.1 Document Purpose

This preinstallation manual provides the necessary information to prepare a site for system installation. Specifically, this manual provides information:

1. To define system requirements and interactions.
2. For the effective arrangement and interconnection of system components.
3. The customer is responsible for:
 - 3.1. Compliance with all local and national codes and regulations
 - 3.2. Siting requirements for customer-specific site procedures (medical, MR, safety, and so on)
 - 3.3. Any special architectural requirements (for example, seismic codes)

The implementation of all requirements and adherence to all specifications in this manual is the responsibility of the customer or its architect and engineers. Refer any questions to the GE HealthCare Project Manager of Installation (PMI).

1.1.2 Intended User

The primary users of this manual are the customer, the customer's architectural planner, and/or the customer's contractors.

1.1.3 Who Should Read This Manual

The following personnel must be aware of the content listed in the following sections:

Table 1-1 Personnel Index















Section	Personnel						
							
	Architect	General Contractor	Customer	Electrician	Plumber	HVAC	RF Vendor
1.1 Preinstall Manual Introduction	X	X	X	X	X	X	X
2.1 Safety Considerations	X	X	X				
2.2 System Level Requirements for Installing into Existing MR Suite	X	X					
2.3 System components	X	X					
2.4 MR Suite Minimum Room Size Requirements	X						
2.5 MR System Seismic Requirements	X	X					
2.6 Structure-borne Vibration Control Specifications	X						
2.7 MR Suite Magnetic Field Specifications	X		X				
2.8 Multiple MR System Requirements	X						
2.9 MR Suite Temperature and Humidity	X	X			X	X	
2.10 Facility Coolant Requirements	X	X			X	X	
2.11 MR Suite Electrical Requirements	X			X			
2.12 MR System Shipping and Receiving	X						
3.1 Magnet Room Introduction	X	X					
3.2 Magnet Room Structural Requirements	X						
3.2.1 Overview	X						
3.2.2 Environmental Steel Limits	X						
3.2.3 Vibration Requirements	X	X				X	
3.3 Magnetic Shielded Room Requirements	X						
3.4 Penetration Panel Wall Opening Requirements	X						









Table 1-1 Personnel Index (Table continued)

Section	Personnel						
							
	Architect	General Contractor	Customer	Electrician	Plumber	HVAC	RF Vendor
3.5.1 Ferrous Materials in the Magnet Room	X	X	X				
3.5.2 Walls	X						
3.5.3 Magnet Preinstallation Markings	X						
3.5.4 Penetration Panel Closet	X						
3.5.5 Penetration Panel Closet Specifications	X						
3.5.6 Doors, Magnet Access Openings, and Patient Viewing Windows	X						
3.5.7 Finished Ceiling	X						
3.5.8 Magnet Room Floors	X	X					
3.5.9 Storage Cabinets	X	X					
3.6 Magnet Room Equipment Specifications	X	X					
3.7 Magnet Room Lighting Requirements	X			X			
4 Equipment Room chapter	X	X					
5 Control Room chapter	X	X					
6 Digital Service and Connectivity chapter	X			X			
7.1 MR System Interconnects Specifications	X	X		X			
7.2 MR System Interconnects Routing Requirements	X	X		X			
7.3 Facility-Supplied System Interconnects Specifications	X	X		X	X	X	
8.1 Glossary	X	X	X	X	X	X	X
8.2 MR Site Vibration Test Guidelines	X						
8.3 Sample Calculation AC Power Equipment Minimum Distance	X						
8.4 Selecting Anchor Size	X	X					
8.5 Sample control schematic for customer-supplied MDP	X			X			

1.1.4 Related Publications

The preinstallation requirements in the following publications are applicable to all systems. This document and all documents referenced herein shall be provided to the Responsible Organization or Operator as a supplement to the product instructions for use and/or technical description.

Table 1-2 Additional Preinstallation Requirements

Publication Number	Title	Personnel Who Must Be Aware Of The Content
5850262-1EN	<i>Acoustic Room Details</i>	
5850261-1EN	<i>International Electrotechnical Commission (IEC) Electro-magnetic Compatibility (EMC)</i>	 
5850263-1EN	<i>Magnet Room Venting</i>	  
5850260-1EN	<i>RF Shielded Room</i>	 







1.1.5 Document Overview

This manual describes requirements and specifications for the following:

1. General system requirements that apply to the entire MR suite
2. Shipping and delivery
3. Magnet Room
4. Equipment Room
5. Control Room
6. Digital Service and Connectivity Requirements
7. Interconnects within and between the rooms listed above

1.2 Symbols Key

Table 1-3 Symbols Key

Symbol/Unit	Definition
	Center of gravity
	Magnet isocenter
	Service area
	Airflow
	Space for airflow and cables
	Valve

2 General System Level

2.1 Safety Considerations



GE HealthCare recommends the use of a 'Safety site readiness checklist', which should list all of the safety related aspects of the installation and should be acknowledged by the relevant parties involved in the installation of the MR equipment before the start of system operation.

The healthcare facility is responsible for establishing a communication plan to train outside emergency personnel (e.g., fire department and other outside emergency personnel) not to bring any ferrous fire-fighting equipment, including axes, ferrous stretchers, or oxygen tanks into the magnet room and other aspects of the hazards related to the MR environment including where the emergency magnet rundown switch is located.

2.2 System Level Requirements for Installing into Existing MR Suite



When planning for the installation of this system in an existing GE HealthCare MR suite or a non-GE HealthCare MR suite, all requirements in this manual must be met because these rooms are considered new installations.

When upgrading from a Signa OpenSpeed system, extensive building updates are required. The facility must remove any Magnet Room isolation system.

1. If the existing MR suite contains a GE HealthCare system, the vibration environmental assessment must be done using the High Speed (magnetic field) Stability tool.



NOTE

The customer may have to hire a vibration consultant based on the results of the analysis.

2. Some GE HealthCare MR suites with overhead cabling may need to be modified to meet current cable tray requirements, such as minimum width and position. See [7.2 MR System Interconnects Routing Requirements on page 112](#).
3. Remove, cover, or fill in abandoned ducts or troughs from the Equipment and Magnet Rooms.

Access/computer room flooring in the Equipment Room can either be removed or assessed and reinforced to support heavier cabinets.

4. Structural vibration levels may be higher at some frequencies than other MR Systems, which may increase acoustic levels. Refer to [2.6 Structure-borne Vibration Control Specifications on page 22](#).
5. The VibroAcoustic damping kit must be surface mounted (if the floor is recessed, it must be filled in and level). For upgrades that reuse the existing magnet, recessed floors can be filled with magnet spacers (25 mm (1 in.) aluminum) that were included when the magnet shipped.
6. RF vendor responsibilities:
 - 6.1. The old dock anchor cannot be reused. It must be removed and the hole filled in. The new anchor is reset after the magnet is installed. For upgrades that reuse the existing magnet, contact the PMI for further details about the potential reuse of the old dock anchor.
 - 6.2. The RF shield ceiling must support the cable routing mechanism and cables. Reinforce RF shield ceiling (see [7.2 MR System Interconnects Routing Requirements on page 112](#)).
 - 6.3. One penetration panel opening is required and must meet the requirements in: *RF Shielded Room Requirements, 5850260-1EN*.
 - 6.4. RF shield attenuation must comply with: *RF Shielded Room Requirements, 5850260-1EN*.
7. Cryogen vent may need to be relocated to align with the Magnet Cryogen Vent opening. The cryogen vent must meet all cryogen venting requirements (see *Magnet Room Venting Requirements, 5850263-1EN*).

2.3 System components



(Applies to all subsections within this section)

This system consists of the following components:

2.3.1 Magnet Room

1. 1.5T Magnet and Magnet Enclosure (MAG) and Vibroacoustic Damping Kit
2. Patient Table (PT)
3. Magnet Rundown Unit (MRU)



NOTE

An optional remote MRU may be located outside the Magnet Room.

2.3.2 Equipment Room

1. Main Disconnect Panel (MDP) (may be customer-supplied in exempt regions)
2. Integrated System Cabinet (ISC)
3. Integrated Cooling Cabinet (ICC)
4. Penetration Panel (PP)
5. Magnet Monitor (MON)
6. Optional:
 - Magnetic Resonance Elastography (MRE)

2.3.3 Control Room

1. Operator Workspace equipment (OW)
2. Pneumatic Patient Alert System (PA1)
3. Optional:
 - Oxygen Monitor (OXY)
 - Physiological Acquisition Transceiver (PAT) Charging Station

2.3.4 Accessories

1. Patient accessories, including RF coils, phantoms, cushions, sponges, straps, and wedges
2. Gating accessories, including patient cardiac leads, peripheral gating probe, and respiratory bellows

2.3.5 System Overview

Figure 2-1 System overview (example)

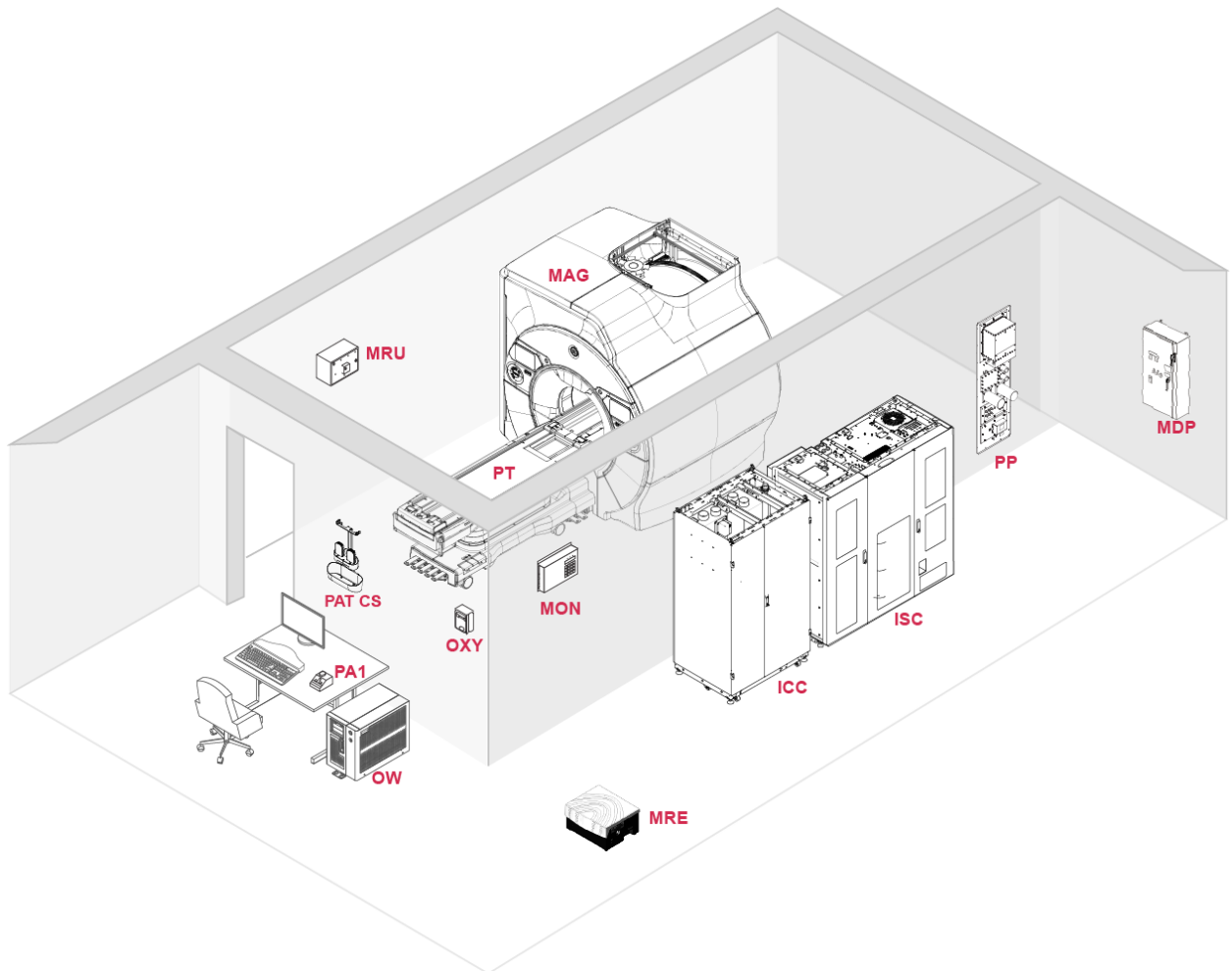

NOTE

MRE, PAT Charging Station and OXY shown above are optional components of the system.

2.4 MR Suite Minimum Room Size Requirements



Room dimensions shown in the table below are the minimum finished room space requirements to safely install and service the MR System. Minimum dimensions are for service only. Room size may increase due to the items listed below, which are not included in the minimum area dimensions:

1. Building code requirements (for example, exit routes, door placement, seismic mounting requirements, local and national electrical codes, and so on).
2. Equipment and Magnet Room evacuation routes to comply with facility emergency procedures.
3. System requirements, including cable run locations, cryogen venting, patient observation requirements, and penetration panel placements.
4. Penetration panel closet and all associated areas.
5. GE HealthCare optional equipment, such as MRE, accessories, and so on.
6. Non-GE HealthCare equipment options (such as additional AC or water cooling equipment in the Equipment Room).
7. Clinical workflow considerations.
8. Adequate space for maneuvering MR conditional mobile equipment to move the patient within the MR environment.
9. Accessory storage. Refer to *Customer Site Storage Requirements*, 5182674 (available in the Customer Documentation Portal), or contact the GE HealthCare Project Manager of Installation (PMI) for any additional accessory storage requirements.
10. Magnetic field containment, for example, the 5 gauss line to the room. If fringe field containment is needed, see [2.7 MR Suite Magnetic Field Specifications on page 24](#).
11. The minimum service area shown must be kept clear of permanent or installed cabinetry, the MRU, the penetration closet, millwork, shelving, coil storage fixtures, furniture, and so on.

Table 2-1 Room Dimensions to Satisfy Minimum Service Area Requirements

Siting Configuration	Equipment Room ¹			Magnet Room ²			Control Room		Total System Area m ² (ft ²)
	W x D mm (in.)	Area m ² (ft ²)	Ceiling Height mm (in.)	W x D mm (in.)	Area m ² (ft ²)	Finished Ceiling Height mm (in.)	W x D mm (in.)	Area m ² (ft ²)	
Minimum Room Size	2441 x 2911 (96.1 x 114.6)	6.1 (66.2)	2680 (105.5)	Short scan range: 3445 x 5727 (135.6 x 225.5)	Short scan range: 17.5 (187.8)	2500 (98.5)	2130 x 1520 (83.9 x 59.8)	3.2 (34.9)	Short scan range: 26.8 (288.9)

Table 2-1 Room Dimensions to Satisfy Minimum Service Area Requirements (Table continued)

Siting Configuration	Equipment Room ¹			Magnet Room ²			Control Room		Total System Area m ² (ft ²)
	W x D mm (in.)	Area m ² (ft ²)	Ceiling Height mm (in.)	W x D mm (in.)	Area m ² (ft ²)	Finished Ceiling Height mm (in.)	W x D mm (in.)	Area m ² (ft ²)	
				Long scan range: 3445 x 5802 (135.6 x 228.4)	Long scan range: 17.7 (190.3)				Long scan range: 27.0 (291.4)

¹ See [Figure 4-1 Typical Minimum Equipment Room with Service Clearances](#) on page 81 for specific dimensions

² See [Figure 2-2 Minimum Magnet Service Area \(Top View\)](#) on page 20 for specific dimensions

Figure 2-2 Minimum Magnet Service Area (Top View)

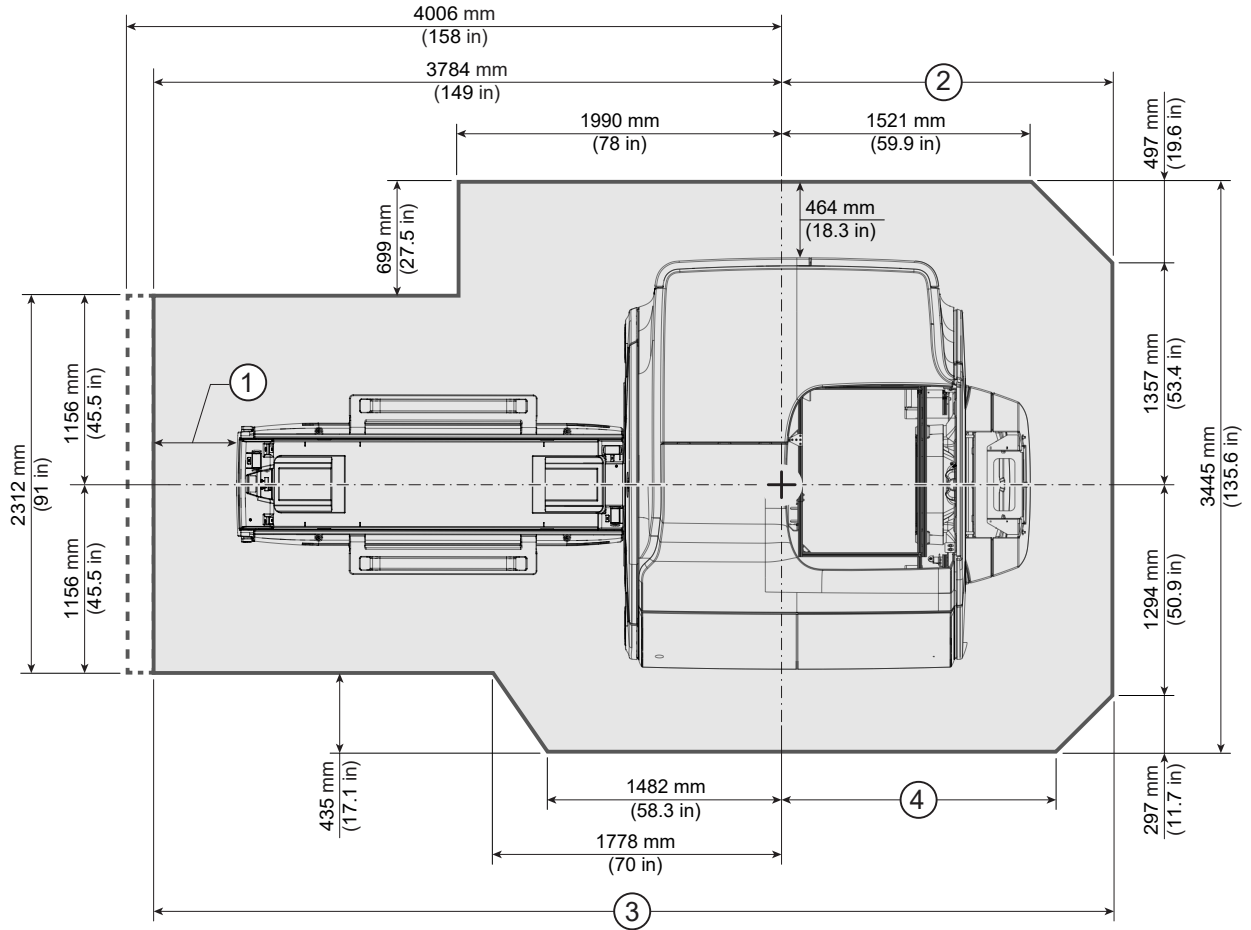

Item	Description
1	444 mm (17.5 in)
2	2018 mm (79.4 in) is for long scan range 1943 mm (76.5 in) is for short scan range
3	5802 mm (228.4 in) is for long scan range 5727 mm (225.5 in) is for short scan range
4	1721 mm (67.8 in) is for long scan range 1691 mm (66.6 in) is for short scan range



NOTE

The shaded area within solid lines indicates minimum service area. Dashed lines indicate the alternate design tradeoff area.

The following requirements apply to the Magnet Room finished ceiling:

1. Ideal Magnet Room suspended ceiling height is 2667 mm (105 in.). Minimum Magnet Room suspended ceiling height is 2500 mm (98.5 in.). See [Figure 2-3 Area for Minimum Magnet Ceiling Height \(Top View\) on page 21](#).
2. The ceiling service area should be kept clear of overhead items, including soffits, HVAC, plumbing components, and brackets. Permanent or installed objects in this area may prevent or delay magnet service or operation.

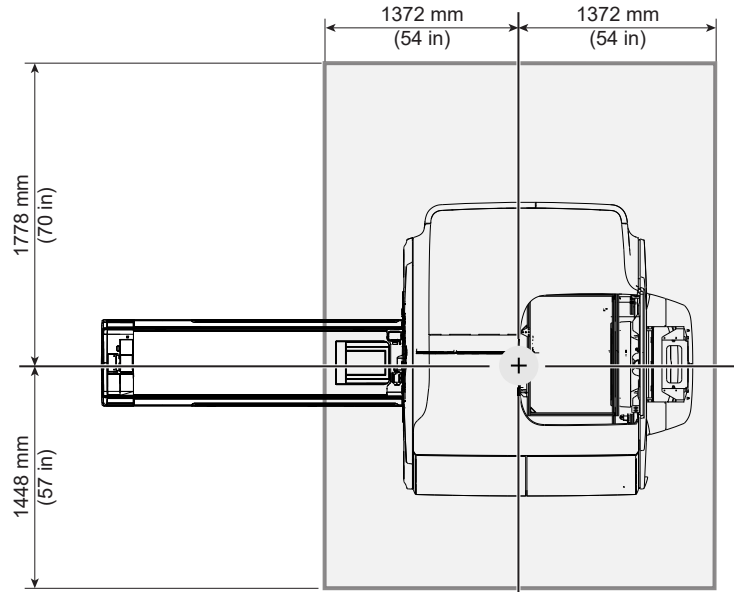
Figure 2-3 Area for Minimum Magnet Ceiling Height (Top View)**NOTE**

The shaded area within solid lines indicates floor to ceiling minimum height of 2500 mm (98.5 in.).

**NOTE**

If the ceiling height is between **2500 mm (98.5 in.)** and **2667 mm (105 in.)**, the flexible main lead extension for low ceiling height (2.5M Low Ceiling Kit-Passive, M7000GM) is required for ramping the magnet. Contact the GE HealthCare PMI and GE HealthCare Service Field Engineer for further evaluation.

2.5 MR System Seismic Requirements



Contact the Project Manager of Installation with any questions.

1. The customer is responsible for seismic anchoring of GE HealthCare components.
2. Center of gravity, weight, physical dimensions, and attachment points are provided for seismic calculations. Refer to the specifications or illustrations for each component (see [Magnet Room Equipment Specifications on page 76](#), [Equipment Room on page 80](#), and [Control Room on page 96](#)).

2.6 Structure-borne Vibration Control Specifications



Structure-borne acoustic issues tend to occur at MR installations above the ground floor of the facility. Two options to mitigate structure-borne acoustic transmission are:

1. GE HealthCare provides a VibroAcoustic Damping kit (which must be surface mounted). Contact the GE HealthCare Project Manager of Installation (PMI) for information.
2. The customer may design and implement a custom solution in addition to the VibroAcoustic Damping kit. See [Figure 2-4 Vibration Transmitted through VibroAcoustic Mat for PM magnet on page 22](#) for the plot of spectral vibration transmitted through the VibroAcoustic mat into the floor. If required, the customer should consult an acoustic engineer for a solution to further attenuate this transmitted vibration).

NOTE
 The amount of vibration attenuation provided by the VibroAcoustic Damping kit will be site dependent.

Figure 2-4 Vibration Transmitted through VibroAcoustic Mat for PM magnet

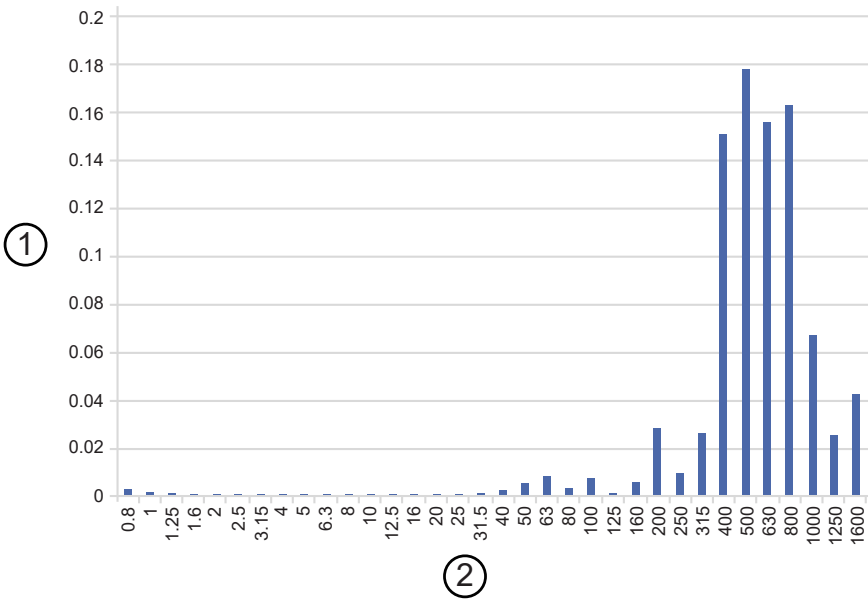

Item	Description
1	Acceleration [m/s ²]
2	1/3 Octave Frequency [Hz]

Figure 2-5 Low Frequency Magnet Floor Vibration (Vibration Amplitude at Each Foot)

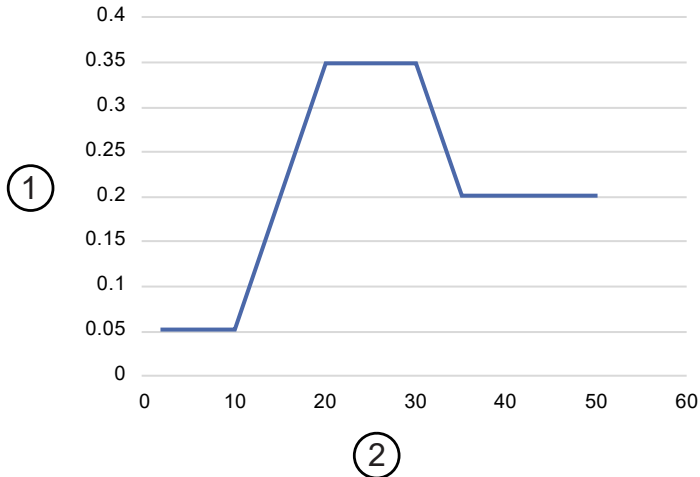

Item	Description
1	Vibration Amplitude [m/s ²]
2	Frequency [Hz]

Frequency (Hz)	Amplitude (m/s ²)
2	0.05
10	0.05
20	0.35
30	0.35
35	0.20
50	0.20

Low Frequency Magnet Floor Vibration Notes:



NOTE

1. Illustrations above define the potential vibration level that may pass into the customer site. [Figure 2-4 Vibration Transmitted through VibroAcoustic Mat for PM magnet on page 22](#) is the high frequency audible vibration. [Figure 2-5 Low Frequency Magnet Floor Vibration \(Vibration Amplitude at Each Foot\) on page 23](#) is low frequency vibration that may dynamically displace the floor.
2. Vibration transfer may be the result of customer specific building construction as low levels of vibration transmit into the building through airborne and structure-borne paths. Customer MR clinicians recognize the vibration defined in the illustrations above is typically short bursts of vibration repeated multiple times as the scan progresses.
3. The customer should consider the impact of this vibration for the evaluation and design solution.

2.7 MR Suite Magnetic Field Specifications



(Applies to all subsections within this section)

2.7.1 Magnetic Fringe Field

The following illustrations show the static magnet isogauss plot lines for the magnet. This information must be used to evaluate potential site interaction of GE HealthCare equipment with other non-GE HealthCare equipment, interaction with ferrous materials on the site, and to locate personnel and equipment within the site.

The 0.5 mT (5G) line can expand to 4.5 m (14.76 ft.) axially and 3.5 m (11.48 ft.) radially for up to 1 second in the rare event of a quench.

The isogauss plots show an idealized magnetic field relative to magnet isocenter. The actual field strength can be affected by any of the following:

- Magnetic shielding
- Earth's magnetic field
- Other magnetic fields
- Stationary or moving metal

Figure 2-6 Magnetic Fringe Field Side View (PM series magnet)

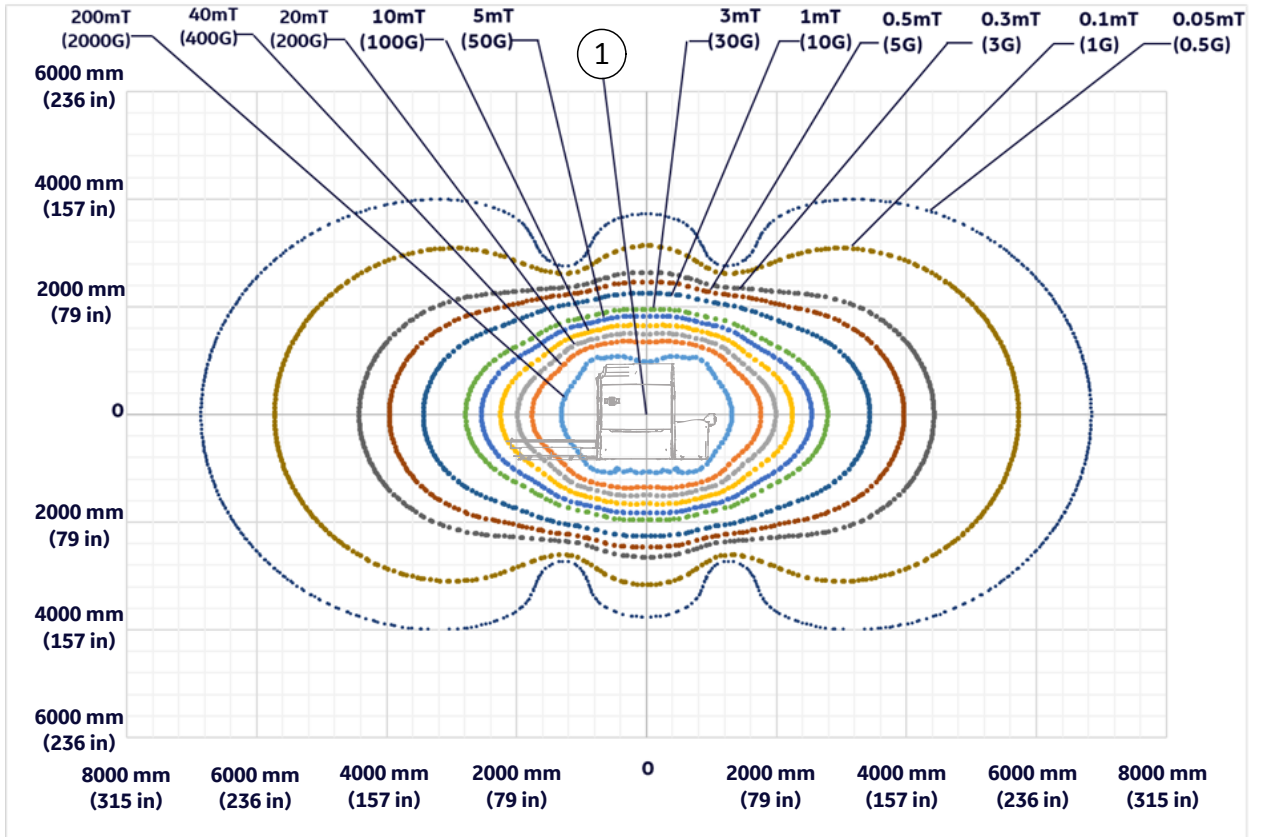

Item	Description
1	Magnet isocenter

Figure 2-7 Magnetic Fringe Field Top View (PM series magnet)

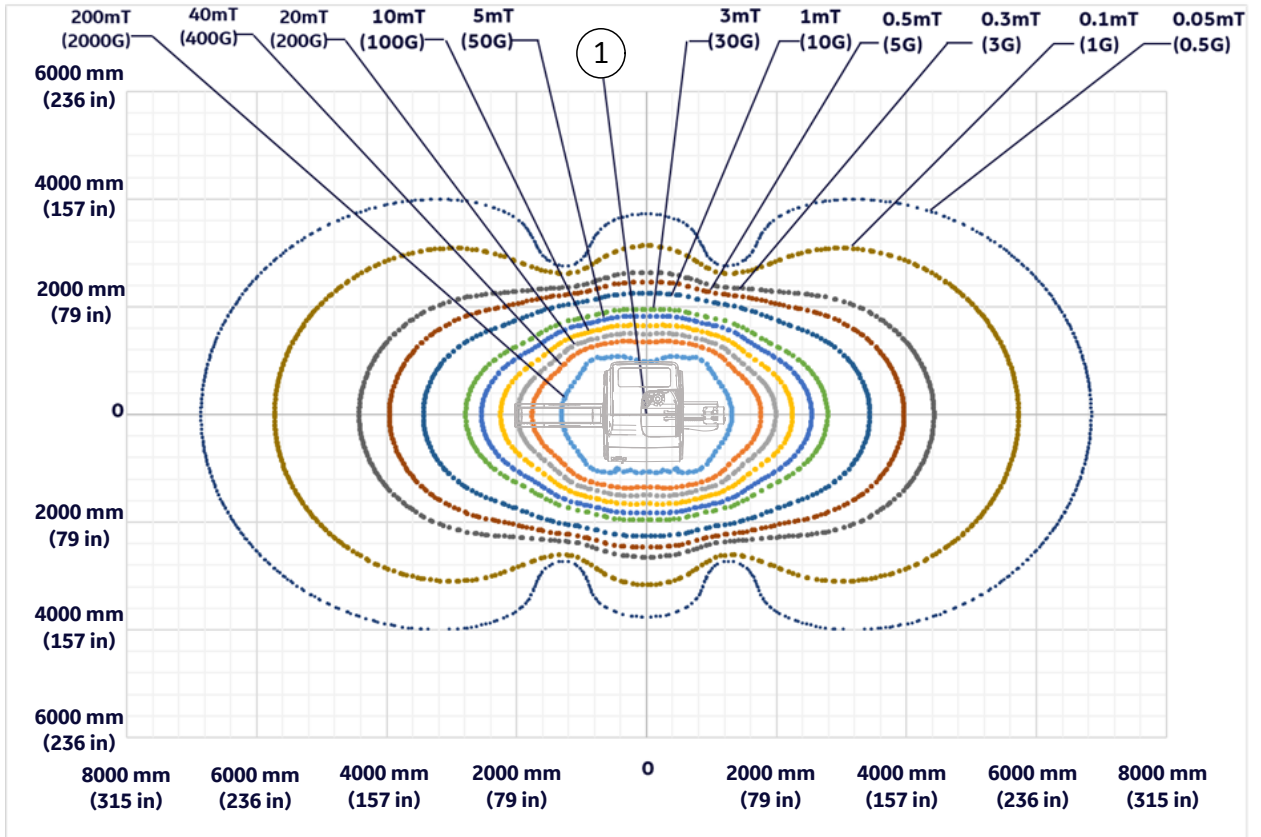

Item	Description
1	Magnet isocenter

Figure 2-8 Magnetic Fringe Field Front View (PM series magnet)

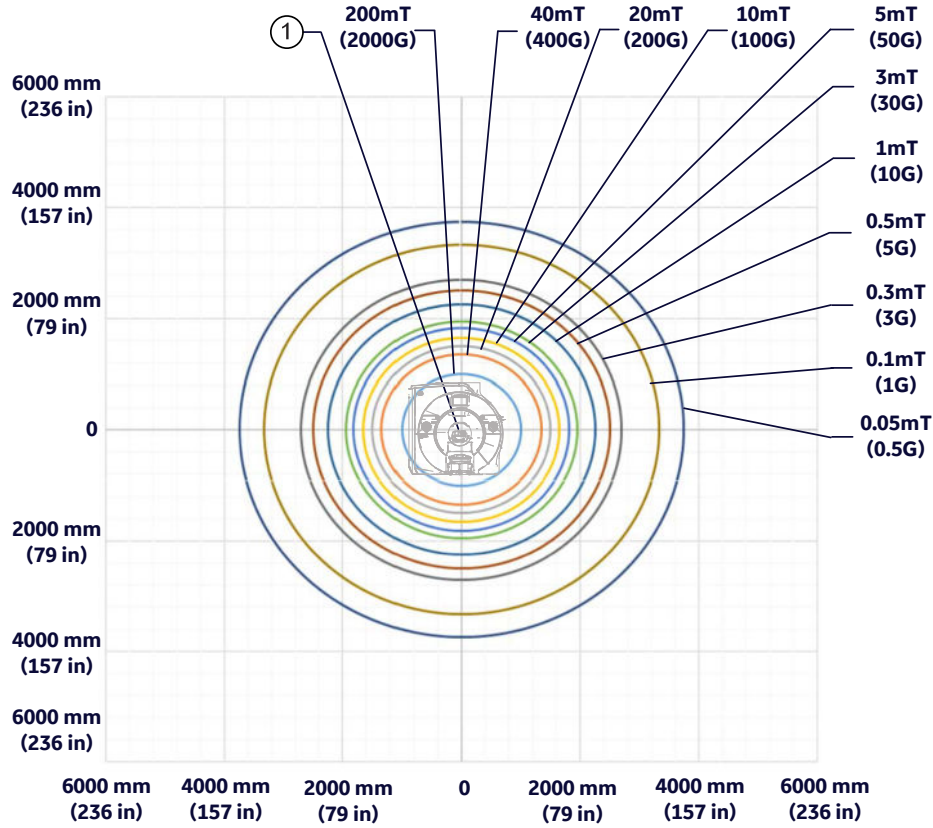

Item	Description
1	Magnet isocenter

2.7.2 Interference from Changing Magnetic Fields

Metal objects moving within the magnet sensitivity lines can produce a field disturbance during clinical imaging. If the metal object is moving it will produce a fluctuating dipole type of field which causes image artifacts. As an example, a car driven inside the moving metal line will act as a dipole and produce a time varying field which changes the magnet's main field during the scanning. The same vehicle may park within the moving metal line and remain parked during clinical scanning without impact to the main field.

Figure 2-9 Magnet Moving Metal Sensitivity Line Plot (Side View)

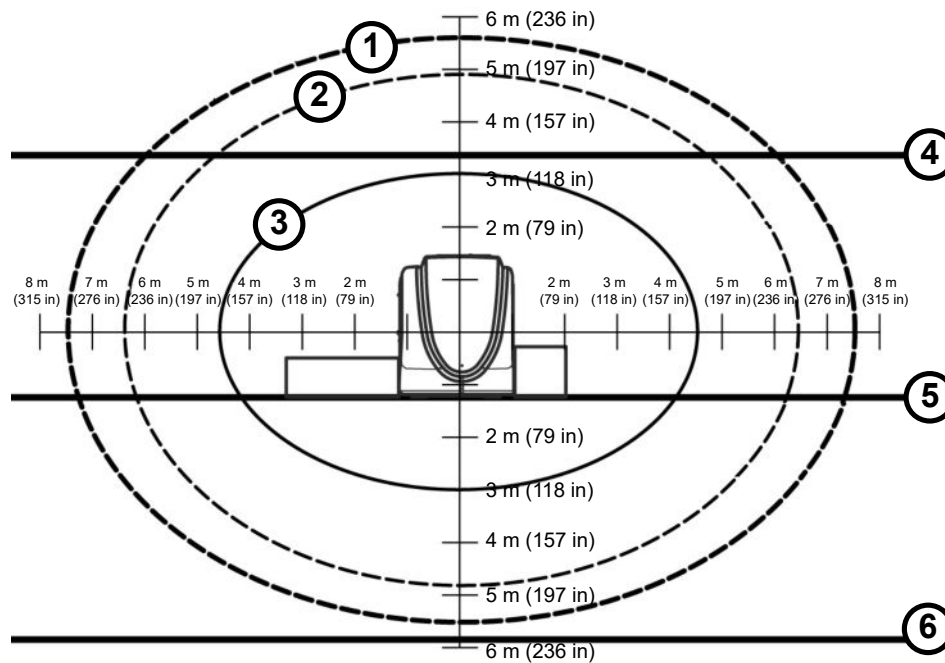

NOTE

The magnet isocenter, which is 1070 mm (42.1 in.) above the floor, is the origin of both the x-axis and the y-axis.

Figure 2-10 Magnet Moving Metal Sensitivity Line Plot (Top View)

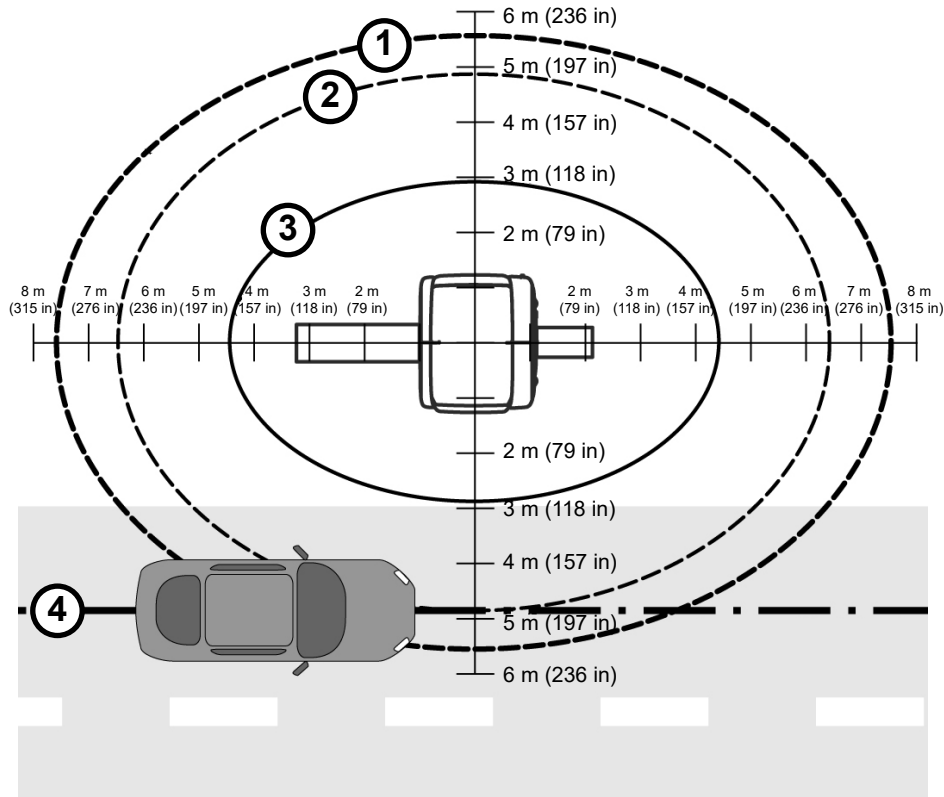

Item	Description	Item	Description
1	Trucks, Buses	3	3 Gauss line
2	Cars, Pickups, Vans, Ambulances	4	Center of Driving Lane

Table 2-2 Magnet Moving Metal Requirements

Metal Objects Category	Definition Of Distance Location	Magnet Minimum Distance Radial X Axial ¹ m (ft.)
Objects 45.36 - 181.44 kg (100 - 400 lb.)	Distance from isocenter radial x axial	0.3 mT (3 G) line
Cars, Minivans, Vans, Pickup Trucks, Ambulances	Distance from isocenter measured to center of driving or parking lane radial x axial	4.72 x 6.40 (15.5 x 21)
Bus, Trucks (Utility, Dump, Semi)	Distance from isocenter measured to center of driving or parking lane radial x axial	5.52 x 7.47 (18.1 x 24.5)
Objects > 181.44 kg (400 lb.), Elevators, Trains, Subways	Place a directional probe (for example, flux gate sensor) at isocenter of proposed magnet location aligned along the Z-axis. Measure peak-to-peak magnetic field change (DC).	See Note 2 below

Table 2-2 Magnet Moving Metal Requirements (Table continued)

Metal Objects Category	Definition Of Distance Location	Magnet Minimum Distance Radial X Axial¹ m (ft.)
<p>Notes:</p> <ol style="list-style-type: none"> 1. Radial distances are magnet X and Y axis. Axial distances are magnet Z axis. 2. EXAMPLE: For moving metal requirements of objects > 181.44 kg (400 lb.) category, you can use the time history of the occurrence to determine what Tesla (Gauss) level to use. <ol style="list-style-type: none"> 2.1. If the site has elevators or counter weights near the magnet and the elevator can stop on the floors for longer than 20 seconds (which is usually the case), the peak-to-peak reading (Z-axis disturbance) must be less than 618 nanotesla (6.18 milligauss). 2.2. If the site has a subway nearby and the field disturbance is less than 2 seconds, the peak-to-peak Tesla (Gauss) reading (Z-axis disturbance) must be less than 618 nanotesla (6.18 milligauss). 2.3. Use 618 nanotesla (6.18 milligauss) peak-to-peak. 		

2.7.3 Electrical Current

1. Electrical current in high voltage power lines, transformers, motors, or generators near the magnet may affect magnetic field homogeneity.
2. Magnetic field interference at 50 or 60 Hz must not exceed 4 μ T (40 mG) RMS at the magnet location (see [Figure 2-11 Magnet Allowable Milligauss vs. Line Frequency for AC Equipment on page 31](#)).
3. The following equation can be used as a general guide in determining allowable current in feeder lines at a given distance from the magnet isocenter:
 - 3.1. For 1.5T Magnet: $I = (20X^2)/S$
 - 3.2. I = Maximum allowable RMS single phase current (in amps) or maximum allowable RMS line current (in amps) in three phase feeder lines
 - 3.3. S = Separation (in meters) between single phase conductors or greatest separation between three phase conductors
 - 3.4. X = Minimum distance (in meters) from the feeder lines to isocenter of the magnet

Figure 2-11 Magnet Allowable Milligauss vs. Line Frequency for AC Equipment

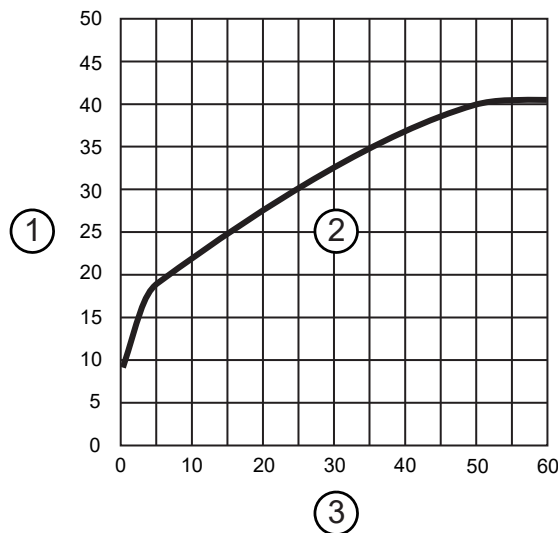

Item	Description	Item	Description
1	Milligauss	3	Excitation Frequency (Hz)
2	No Impact on Imaging		

Refer to [Sample Calculation AC Power Equipment Minimum Distance on page 129](#) for additional examples.

2.7.4 Non-MR System Equipment Sensitivity to Magnetic Fields

Site plans must include consideration for magnetic field interaction with all customer equipment.

This section lists equipment known to be sensitive to high magnetic fields.

Use the table for reference only. The Tesla (Gauss) limits in the table are approximate for that type of equipment. Refer to OEM manuals for the equipment at your site to determine the actual Tesla (Gauss) limits.

Make sure any third-party equipment or accessories are selected as appropriate for safe use in the MR environment.

Table 2-3 Magnetic Proximity Limits (For Reference Only)

mT (Gauss) Limit	Equipment	
0.05mT (0.5 G)	Nuclear camera	
0.1mT (1 G)	Positron Emission Tomography scanner	Video display (tube)
	Linear Accelerator	CT scanner
	Cyclotrons	Ultrasound
	Accurate measuring scale	Lithotripter
	Analog image intensifiers	Electron microscope
	Bone Densitometers	
0.3mT (3 G)	Power transformers	Main electrical distribution transformers
0.5mT (5 G)	Cardiac pacemakers	Biostimulation devices
	Neurostimulators	
1mT (10 G)	Magnetic computer media	Telephone switching stations
	Hard copy imagers	Water cooling equipment
	Line printers	HVAC equipment
	Video Cassette Recorder (VCR)	Major mechanical equipment room
	Film processor	Credit cards, watches, and clocks
	X-ray tubes	
	Large steel equipment, including:	
	Emergency generators	Air conditioning equipment
	Commercial laundry equipment	Fuel storage tanks
	Food preparation area	Motors greater than 5 horsepower
5mT (50 G)	Metal detector for screening	Telephones
	LCD panels	
No Limit	Digital Detectors	

2.8 Multiple MR System Requirements



(Applies to all subsections within this section)

2.8.1 Multiple Magnets

When installing multiple magnets, the 0.3 mT (3 G) lines must not intersect or the magnets will be interactive. Contact the GE HealthCare Project Manager of Installation (PMI) for any questions regarding magnetic field interaction.

Magnet Rooms cannot share walls.

Figure 2-12 Two Magnet Installation (No Interaction)

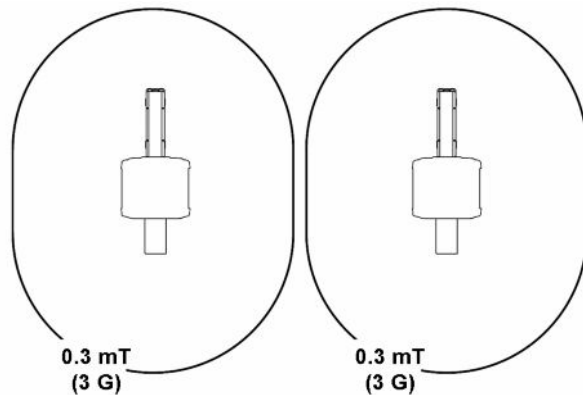

2.8.2 Shared Equipment Rooms

When installing multiple MR Systems in a shared Equipment Room, of the same field strength, the following conditions must be met:

1. The RF cabinet of the existing installed system must be separated from the RF bay of the ISC by at least 2000 mm (79 in.).

This requirement does not apply if the existing 1.5T system is one of the following: 1.5T SIGNA HDxt – SIGNA Works Edition (HD28), Brivo MR355/MR360, SIGNA Prime, SIGNA Creator/Explorer, SIGNA Star, SIGNA Star AIR, SIGNA Aviator, SIGNA Aviator AIR, SIGNA MR355/360, SIGNA MR380, SIGNA Victor, SIGNA Prime MAX, SIGNA Prime Elite, SIGNA Voyager, SIGNA Voyager AIR, Discovery MR450, Optima MR450w, SIGNA Artist, SIGNA Artist Evo, SIGNA Winner, SIGNA Champion, SIGNA Sprint, SIGNA Sprint Select, or SIGNA Sprint Evo.

2. The penetration panel of the other system must be separated from the penetration wall of the ISC by at least 3000 mm (118 in.).
3. Cables from different MR Systems must not be routed together.
4. Two systems cannot share common power or ground feeds.

**NOTE**

The distances shown in [Figure 2-13 Cabinet Separations in Shared Equipment Room \(Top View\)](#) on [page 34](#) must be maintained between the RF cabinet of the new system and existing RF cabinet of a non-GE HealthCare MR System. The distance is based on the location of the RF amplifier that is inside the ISC, not the location of the ISC.

* The 2000 mm (79 in.) requirement does not apply if the existing system is one of those listed in the requirements in [item 1](#) above.

Figure 2-13 Cabinet Separations in Shared Equipment Room (Top View)

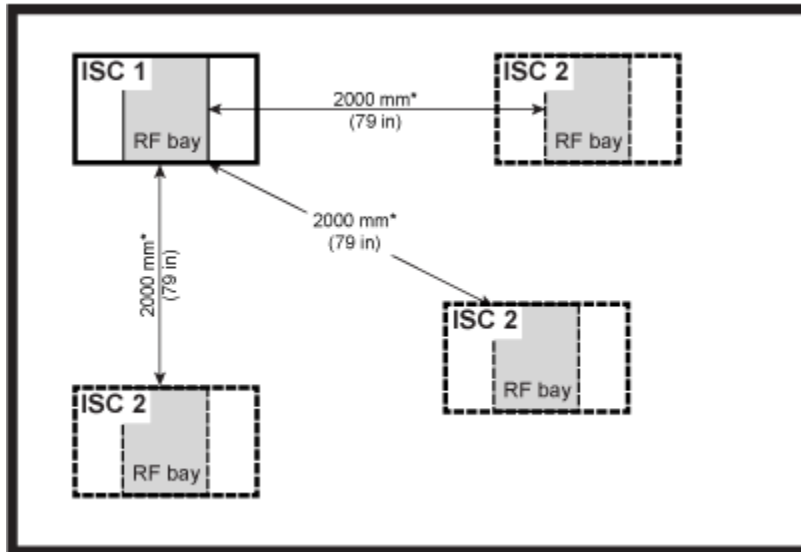
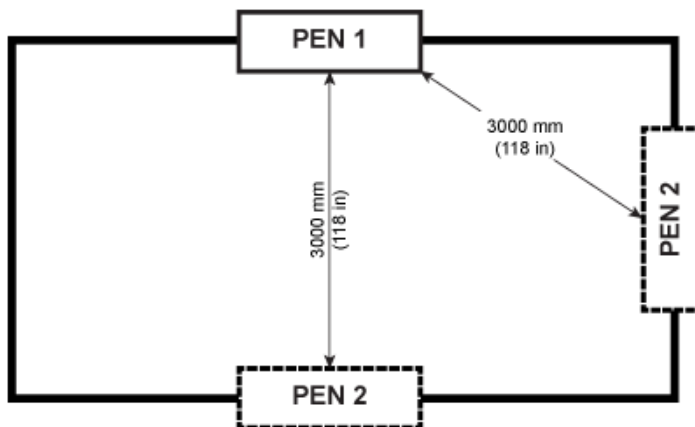

Figure 2-14 Panel Separations in Shared Equipment Room (Top View)



2.9 MR Suite Temperature and Humidity



(Applies to all subsections within this section)

This section provides temperature and humidity requirements for the MR suite.



NOTE

Make sure the HVAC system has the correct capacity for the room size, equipment heat output, and environmental conditions to maintain correct temperature and humidity for the protection of the patient.

Specific construction requirements for each room can be found in the following chapters:

- Magnet Room
- Equipment Room
- Control Room

2.9.1 Temperature and Humidity Requirements

1. The customer is responsible for HVAC system design, purchase, and installation.
2. The temperature and humidity requirements must not be exceeded at any point during the day (both working or non-working hours).
3. A separate thermostat must be provided for the Magnet Room.

Table 2-4 Room Temperature and Humidity Requirements

Room	Temperature		Humidity	
	Range °C (°F)	Change °C/Hr (°F/Hr) ¹	Range %RH	Change %RH/Hr ²
Equipment Room (at Inlet to Equipment)	15-32 (59-89.6) ³	3 (5)	30-75	5
Magnet Room	15-21 (59-69.8)	3 (5)	30-60	5
Operator Room	15-32 (59-89.6)	3 (5)	30-75	5

Notes:

1. Operating temperature gradient limits shall be between -3°C/Hr (-5°F/Hr) and 3°C/Hr (5°F/Hr), when averaged over 1 hour.
2. Operating humidity gradient limits shall be between -5% RH/hour and 5% RH/hour, when averaged over 1 hour.
3. Maximum ambient temperature is derated by 1°C per 175 m above 950 m (not to exceed 2999 m).

2.9.2 Equipment Heat Output Specifications

This section details the heat output for specific components. These heat outputs define the minimum, maximum and an assumed average condition over a 12-hour period. Actual heat output and room temperature may vary due to environmental factors, room insulation, clinical usage, and any non-GE HealthCare equipment used in the MR suite. Also, due to large variations in heat loads, the HVAC system may require unloaders, hot gas bypass, and reheat to maintain humidity levels.

Table 2-5 System Heat Output for Air Cooling

Component	Magnet Room W (BTU/hr)			Equipment Room W (BTU/hr)			Control Room W (BTU/hr)		
	Maximum	Average	Idle	Maximum	Average	Idle	Maximum	Average	Idle
Magnet (MAG) and Patient Transport Table (PT)	2400 (8189)	1200 (4095)	561 (1915)						
Penetration Panel (PP)	300 (1023)	150 (512)	0	300 (1023)	150 (512)	0			
Main Disconnect Panel (MDP)				285 (972)	132 (450)	132 (450)			
Integrated System Cabinet (ISC)				11500 (39215)	5500 (18755)	2950 (10060)			
Integrated Cooling Cabinet (ICC)				1000 (3410)	600 (2046)	250 (853)			
Cryocooler Compressor (CRY)				500 (1706)	500 (1706)	500 (1706)			
Magnet Monitor (MON)				60 (205)	60 (205)	60 (205)			
Operator Workspace equipment (OW)							1450 (4945)	1450 (4945)	1450 (4945)

Table 2-6 System Options Heat Output for Air Cooling

Component	Magnet Room W (BTU/hr)			Equipment Room W (BTU/hr)			Control Room W (BTU/hr)		
	Maximum	Average	Idle	Maximum	Average	Idle	Maximum	Average	Idle
MR Elastography (MRE)				141 (480)					

2.10 Facility Coolant Requirements



(Applies to all subsections within this section)



IMPORTANT

Equipment Failure. A continuous supply of facility liquid coolant to the Integrated Cooling Cabinet (ICC) is required at all times for correct system operation. Failure to provide liquid coolant with the requirements listed in this section may cause equipment failure.

2.10.1 Integrated Cooling Cabinet (ICC) Coolant Requirements

1. The facility must provide an uninterrupted supply of liquid coolant to the Integrated Cooling Cabinet (ICC) at magnet delivery. Coolant circuit must be operational at magnet delivery.
2. The facility must provide pipe/hose, filter, and connectors to the ICC.
3. The vertical distance between the coolant connection points of the ICC and the Gradient Coil must be less than ± 5 meters (± 196.8 in.).
4. The customer must provide and install an in-line flow meter on either the supply or return facility coolant hose. The flow meter must be capable of visually displaying volumetric flow between 76 and 189 L/min (20 and 50 GPM) and configured for the properties of the cooling fluid in use within the ICC coolant circuit.

Table 2-7 Facility Liquid Coolant Requirements

Parameter	Requirements
Availability	Continuous
Antifreeze or treated process water	No more than 50% propylene glycol-water (PGW) or ethylene glycol-water (EGW)
Minimum Flow	114 L/min (30 GPM)
Maximum Flow	132 L/min (35 GPM)
Maximum Pressure Drop in ICC at Minimum Flow	2.2 bar (32.0 psi) with 50% propylene glycol-water; 1060 kg/m ³ density 1.9 bar (26.9 psi) with pure water; 994 kg/m ³ density
Maximum Pressure Drop in ICC at Maximum Flow	2.9 bar (42 psi) with 50% propylene glycol-water; 1060 kg/m ³ density 2.6 bar (37.3 psi) with pure water; 994 kg/m ³ density
Temperature rise at Minimum Flow	10.4°C (18.7°F) with 50% propylene glycol-water; 3346 J/(kg K) specific heat; 1060 kg/m ³ density; 70 kW heat
Temperature rise at Maximum Flow	9.0°C (16.1°F) with 50% propylene glycol-water; 3346 J/(kg K) specific heat; 1060 kg/m ³ density; 70 kW heat
Maximum Inlet Pressure to ICC	6 bar (87 psi)
Chiller Size	Minimum 70 kW
Condensation Protection	Facility Plumbing to the ICC must be properly routed and insulated to prevent equipment damage or safety hazards

Table 2-7 Facility Liquid Coolant Requirements (Table continued)

Parameter	Requirements
Minimum Continuous Heat Load	7.5 kW
Inlet Temperature	5 to 15°C (41 to 59°F) measured at the inlet to the ICC
Customer supplied feeder hose (from main water supply to ICC)	38.1 mm (1.5 in.) minimum hose inside diameter
Hose connections to the ICC	38.1 mm (1.5 in.) male NPT

Figure 2-15 Allowable Facility Water Temperature and Flow

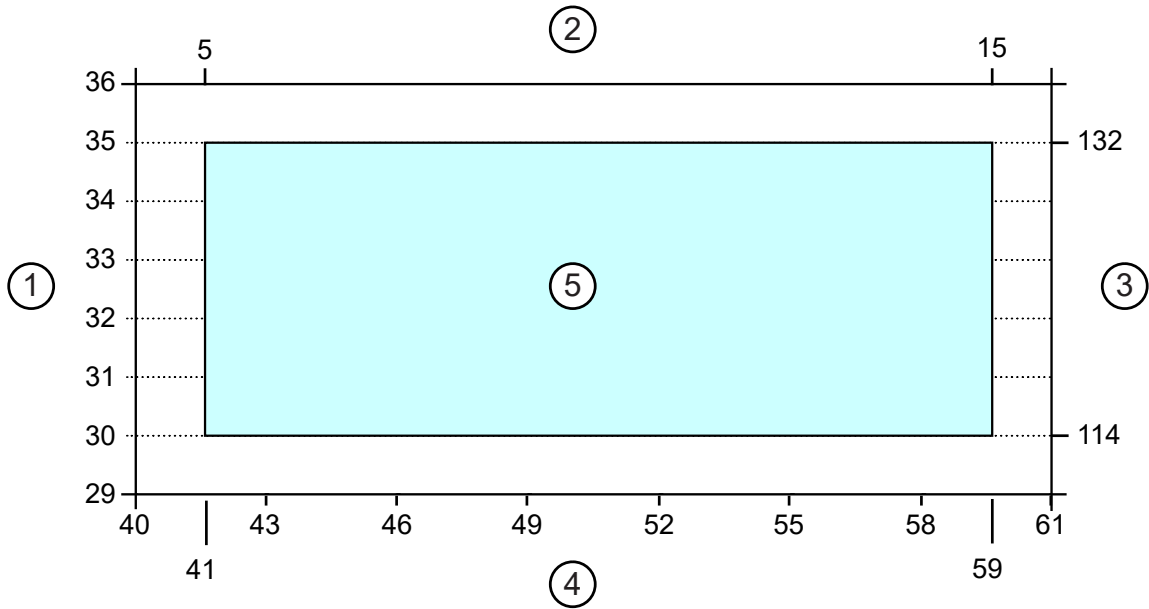

Item	Description	Item	Description
1	Flow [gpm]	4	Temperature [°F]
2	Temperature [°C]	5	0-50% Propylene or Ethylene Glycol
3	Flow [L/min]		

Figure 2-16 Pressure Drop through ICC (50% PGW, 1060 kg/m³)

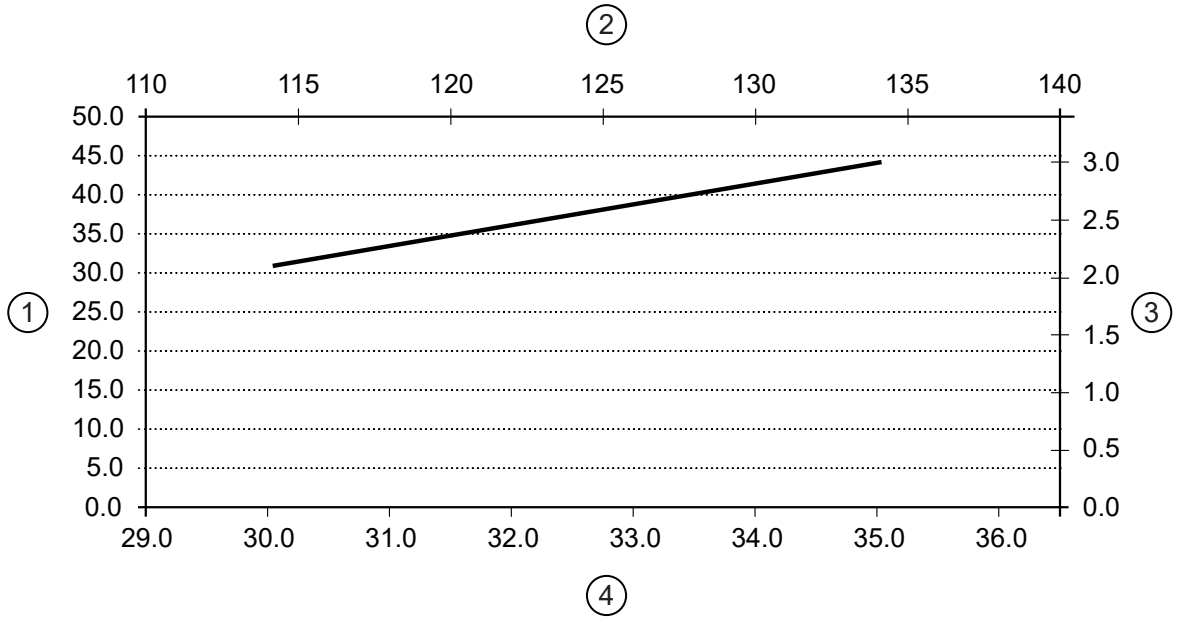

Item	Description	Item	Description
1	Pressure [psig]	3	Pressure [bar]
2	Flowrate [L/min]	4	Flowrate [gpm]

Figure 2-17 Temperature Rise through ICC (50% PGW, 3346 J/kg-K, 1060 kg/m³)

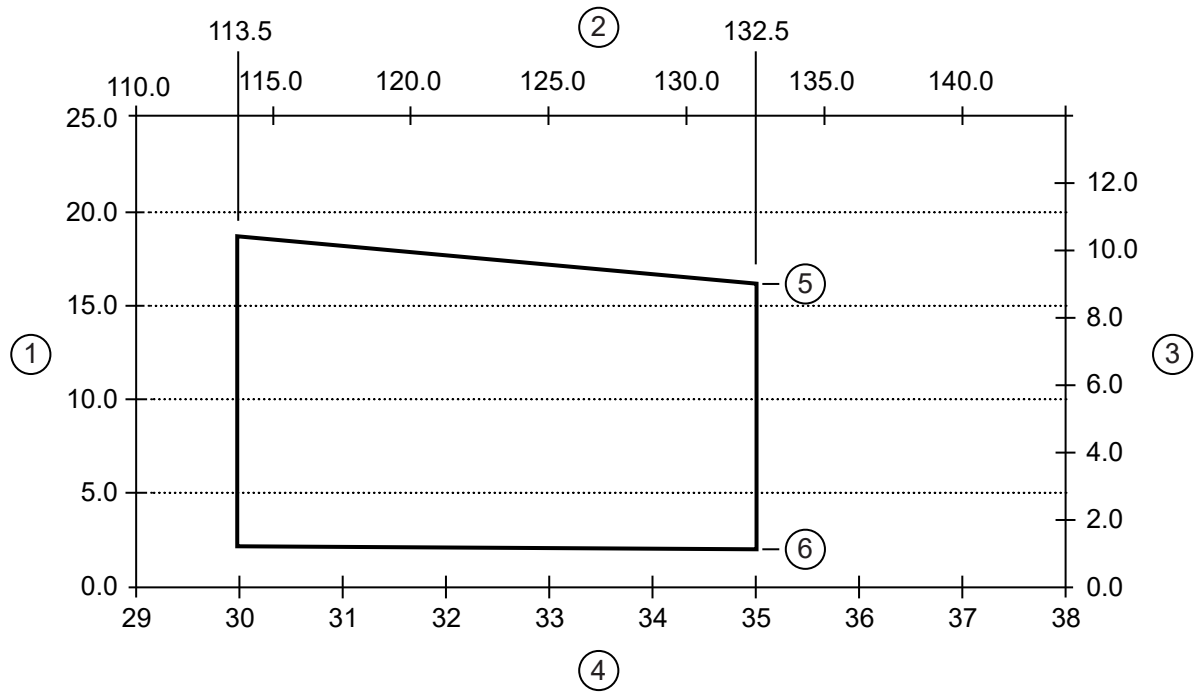

Item	Description	Item	Description
1	Temperature Rise [°F]	4	Flowrate [gpm]
2	Flowrate [L/min]	5	Max Heat Load: 70kW
3	Temperature Rise [°C]	6	Min Heat Load: 7.5kW

Table 2-8 Facility Water Quality Requirements

Parameter	Requirement
pH Value	6.5 to 8.2 at 25 °C (77 °F)
Electrical Conductivity	< 0.8 mmho/cm
Chloride Ion	< 200 ppm
Sulfate Ion	< 200 ppm
M-Alkalinity	< 100 ppm
Total Hardness	< 200 ppm
Calcium Hardness	< 150 ppm
Ionic Silica	< 50 ppm
Iron	< 1.0 ppm
Copper	< 0.3 ppm
Sulfide Ion	None, not detectable
Ammonium Ion	< 1.0 ppm
Residual Chlorine	< 0.3 ppm
Free Carbon Dioxide	< 4.0 ppm

Table 2-8 Facility Water Quality Requirements (Table continued)

Parameter	Requirement
Stability Index	6.0 to 7.0
Suspended Matter	< 10 ppm
Particle Size	< 100 micron (with field changeable filter)

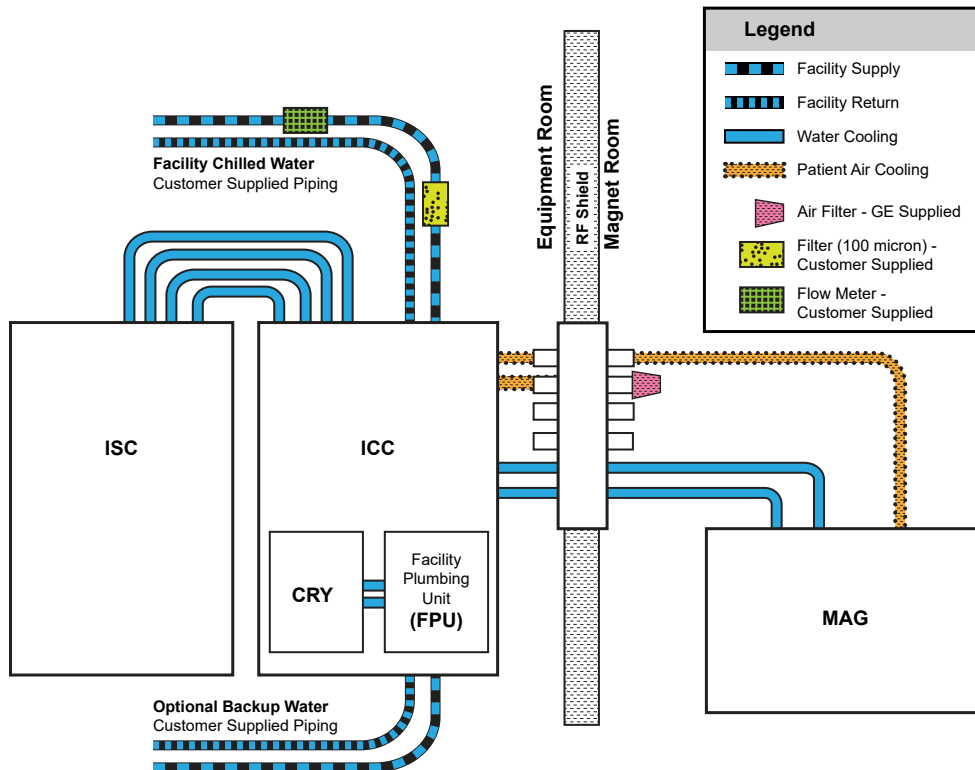
Figure 2-18 MR System Water Cooling Block Diagram

2.10.2 Requirements for Emergency Backup Facility Coolant (Optional)

The customer must balance the cost of cryogenes and local controls with the cost of emergency backup facility coolant. There are two options for emergency backup, either total ICC backup or Cryocooler Compressor backup.

The facility may provide an optional emergency backup coolant supply in one of the following configurations:

1. Total ICC backup:
 - 1.1. The facility is responsible for the connection of all hoses of a backup system.
 - 1.2. Coolant must meet all other ICC coolant requirements listed in [2.10.1 Integrated Cooling Cabinet \(ICC\) Coolant Requirements on page 37](#).

2. Cryocooler Compressor backup only:
Backup coolant may be routed to the ICC backup water port for the Cryocooler compressor at the location indicated in [Figure 2-18 MR System Water Cooling Block Diagram on page 41](#) with the following requirements:
 - 2.1. The emergency coolant supply must be drained to the facility through customer supplied 12.5 mm (0.5 in.) hose and must not back-feed to the ICC.
 - 2.2. Coolant must meet all other ICC coolant requirements listed in [2.10.1 Integrated Cooling Cabinet \(ICC\) Coolant Requirements on page 37](#).
 - 2.3. The facility is responsible for coolant, 12.5 mm (0.5 in.) pipe/hose, filters, and connectors to supply the coolant to the ICC emergency facility coolant supply line (12.5 mm (0.5 in.) hose with a female threaded connector). The emergency coolant supply line is available from the Facility Plumbing Unit on the ICC. The hose comes out from the bottom rear of the ICC.
 - 2.4. The charts below show the coolant flow rate and temperature requirements for the Cryocooler Compressor:

Figure 2-19 Cryocooler Water Cooling Requirements

For Water

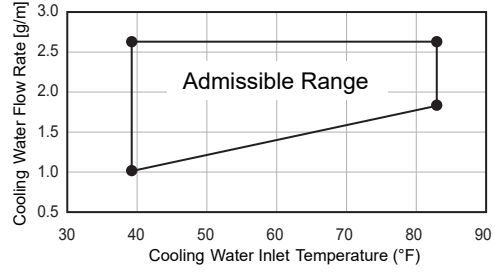
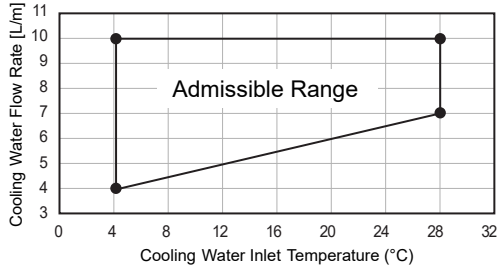

For Antifreeze

(50/50% mixture of water and ethylene glycol or propylene glycol.)

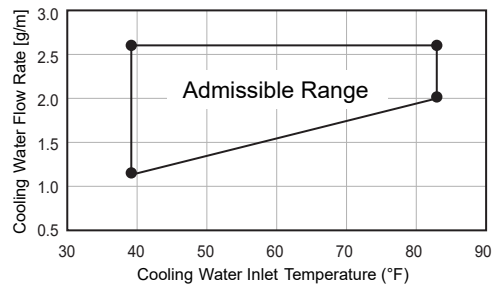
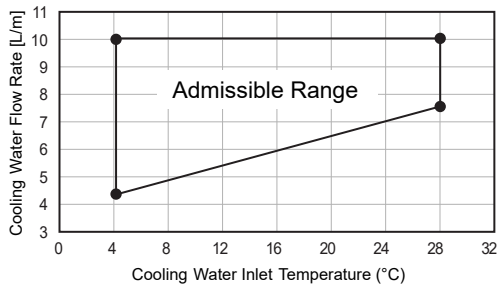

Pressure Drop and Temperature Rise

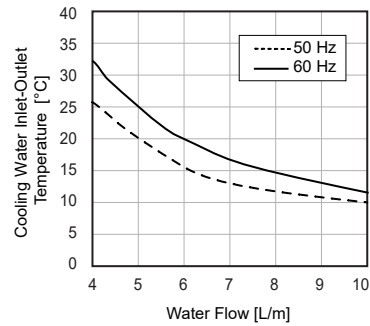
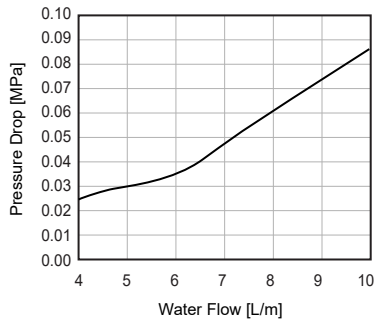

2.11 MR Suite Electrical Requirements

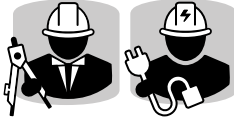

(Applies to all subsections within this section)

2.11.1 General Electrical Requirements

1. Customer is required to install a Main Disconnect Panel (MDP):
 - 1.1. For GE HealthCare supplied MDP, M7100MD Design setup, see [2.11.2 GE HealthCare Supplied Main Disconnect Panel \(MDP\) Specifications for M7100MD on page 46](#).
 - 1.2. For Customer-supplied MDP:
 - 1.2.1. Customer-supplied MDP may not be permissible in all regions. Contact your GE HealthCare Project Manager of Installation (PMI) to verify local requirements.
 - 1.2.2. MDP Design Requirements: [2.11.3 Customer-supplied Main Disconnect Panel \(MDP\) Requirements \(exempt countries only*\) on page 49](#).
 - 1.2.3. MDP Design Setup [Figure 2-21 Customer-supplied MDP MR System Main Disconnect Panel \(MDP\) Setup on page 51](#).
2. At least one remote Emergency Off push-button shall be installed in a location that is visible and accessible to the device operator (Control Room or Magnet Room). The push-button shall be normally closed and require operator action to release after activation (for example, twist and pull). GE HealthCare recommends installing two remote Emergency Off push buttons, installed in the Control Room and Magnet Room.
3. The facility must provide system power to the MDP.
4. All associated transformers and cables must be correctly sized for system power requirements.
5. The facility must connect the GE HealthCare supplied cabling from the MDP to the Cryocooler Compressor (F-50SH) in the Integrated Cooling Cabinet (ICC).
6. Runs E0007, E0009, E3030 and M3030 are supplied by GE HealthCare. All other wiring shown in [2.11.2 GE HealthCare Supplied Main Disconnect Panel \(MDP\) Specifications for M7100MD on page 46](#) and [2.11.3 Customer-supplied Main Disconnect Panel \(MDP\) Requirements \(exempt countries only*\) on page 49](#) must be customer-supplied and installed. A customer-supplied substitute for E0009 can be used if the supplied run is shorter than required.
7. All feeder circuits require dedicated ground wires.

Table 2-9 Facility Power Requirements

Component	Parameter	Requirements	
At Main Disconnect Panel (MDP)	Voltage / Frequency	480 VAC	60 ±3 Hz
		415 VAC	50 ±3 Hz, 60 ±3 Hz
		400 VAC	50 ±3 Hz, 60 ±3 Hz
		380 VAC	50 ±3 Hz, 60 ±3 Hz

Table 2-9 Facility Power Requirements

Component	Parameter	Requirements	
	Daily Voltage Variation	Customer to provide +10% / -10% from nominal at MDP input under all line and load conditions. This includes variation of power source and transmission losses up to the MDP.	
	Phase	Input power to the MDP may use one of the following configurations: <ul style="list-style-type: none"> A 3 phase solidly grounded WYE with Ground (3 Wire + Ground) A neutral conductor is not required for MR System operation. If a neutral conductor is present, it can be terminated on the neutral bus provided in the GE HealthCare-supplied MDP. A 3 phase floating DELTA with Ground (3 Wire + Ground). Do not connect a corner grounded DELTA source. Note: Some UPS options may require a neutral (refer to manufacturer documentation for requirements).	
	Phase Balance	Difference between the highest phase line-to-line voltage and the lowest phase line-to-line voltage must not exceed 2%	
	Power Quality	Recommended THD-V of less than 2.5%	
	Facility Zero Voltage Reference Ground	<ul style="list-style-type: none"> The facility ground for the MR System must originate at the system power source (that is, transformer or first access point of power into the facility) and be continuous to the MR System Main Disconnect Panel (MDP) in the room. Main facility ground conductor to Main Disconnect Panel (MDP) must be appropriately sized insulated copper wire. The main facility ground to the Main Disconnect Panel (MDP) must meet local codes. 	
	Power Availability	Continuous facility power is required at all times for operation of the Cryocooler (CRY) to minimize cryogen consumption.	
Service receptacle in Magnet Room	Voltage / Frequency	100-120 VAC 60 Hz (North America) 200-240 VAC 50/60 Hz (International)	Receptacle required for small power tools. Local voltage and portable transformers for voltage values.
	Phase	1	
	Maximum Current	20A (North America) 16A (International)	
Pneumatic Patient Alert	Voltage / Frequency	100-120 VAC 60 Hz (North America) 200-240 VAC 50/60 Hz (International)	The Control Box must be mounted within reach of the operator and within 1.5 m (5 ft.) of an electrical outlet.
	Phase	1	
	Maximum Current	20A (North America) 16A (International)	
Magnet Rundown Unit (MRU)	Voltage / Frequency	100-120 VAC 60 Hz (North America) 200-240 VAC 50/60 Hz (International)	Connection type: Hardwired or permanently wired directly to facility power, no plugs or connectors allowed. 25 mm (1 in.) PVC Schedule 40 Conduit recommended Availability: Continuous Circuit Breaker: Dedicated AC disconnect required for both live and neutral connections
	Phase	1	

Table 2-9 Facility Power Requirements (Table continued)

Component	Parameter	Requirements	
	Maximum Current	1A	
Magnet Monitor (MON)	Voltage / Frequency	100-120 VAC 60 Hz (North America) 200-240 VAC 50/60 Hz (International)	Power at the outlet must be continuously available.
	Phase	1	
	Maximum Current	3A	
Optional MRE Re-soundant Acoustic Driver	Voltage / Frequency	100-120 VAC 60 Hz (North America) 200-240 VAC 50/60 Hz (International)	
	Phase	1	
	Maximum Current	20A (North America) 16A (International)	
Oxygen Monitor (OXY) Option	Voltage / Frequency	100-120 VAC 60 Hz (North America) 200-240 VAC 50/60 Hz (International)	Connection type: Hardwired in unit
	Phase	1	
	Maximum Current	0.9A	
Optional Physiological Acquisition Transceiver (PAT) Charging Station	Voltage / Frequency	100-120 VAC 60 Hz (North America) 200-240 VAC 50/60 Hz (International)	The charging station must be mounted within 3000 mm (118 in.) of an electrical outlet.
	Phase	1	
	Maximum Current	1.5A	

Table 2-10 System Power Demand

Equipment	Power Draw (kVA)
ISC System PDU Continuous Power	20
ISC Gradient PDU Continuous Power	70
Cryocooler Compressor Continuous Power	9
Total system Continuous Power	99
Total System 50 Millisecond Power	205

2.11.2 GE HealthCare Supplied Main Disconnect Panel (MDP) Specifications for M7100MD

The customer is responsible for determining the suitability of the GE HealthCare supplied MDP with respect to governing electrical codes.

The GE HealthCare MDP consists of the following:

- A 3-pole main circuit breaker rated for the total current of all the sub-breaker circuits.
- A 3-pole circuit breaker rated for the current of the Gradient PDU circuit.
- A 3-pole circuit breaker rated for the current of the System PDU circuit.
- A 3-pole circuit breaker rated for the current of the Cryocooler Compressor (CRY).
- All circuit breakers have a short circuit current interrupting rating of 25000 Amps at 480V and Icc rating of 25000 Amps at 415V.
- Auto restart on the Cryocooler circuit following loss and restoration of power.
- Two remote Emergency Off Buttons to be installed external to the MDP. Emergency Off removes power from all outputs when activated. MDP supports maximum E-off cable length of 100 meters when remote EPO push buttons are installed in the field.
- Terminal blocks that can accept wire sizes for M7100MD are listed under [Table 2-12 GE HealthCare Supplied MDP - Range of Standard stranded Conductors Accepted for M7100MD on page 49](#).
- Provision for terminating facility incoming neutral wire on the neutral terminal block.
- Multiple ground terminal blocks as required by panel design.
- GE HealthCare MDP M7100MD is listed and labeled by Nationally Recognized Testing Lab (NRTL) in accordance with UL 508A and bears UL and CE mark. These MDPs are certified as per “UL 508A and IEC 61439-2” standards.
- Power on indicator for main breaker output power.
- Two isolated, normally open contact pairs that open when e-OFF is pressed or facility power is interrupted for use with optional accessories.
- Capability for single point lock-out/tag-out for the entire system (Mains Disconnect / Input Breaker) and a means to lock-out/tag-out each output breaker independently. All LOTO points support a standard sized hasp for lock-out.

Figure 2-20 GE HealthCare supplied Main Disconnect Panel (MDP) Setup for M7100MD

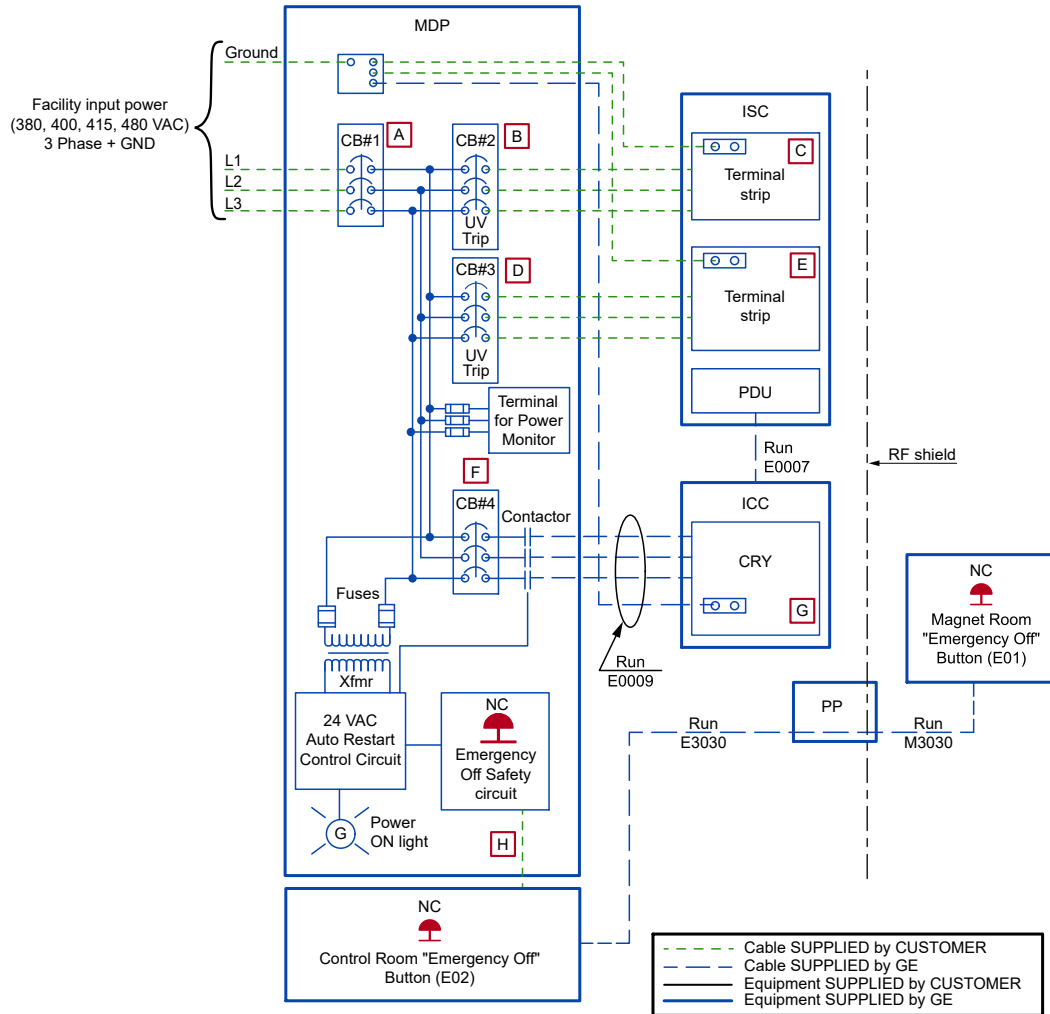

Table 2-11 GE HealthCare supplied MDP - Breaker Sizes for M7100MD

Catalog Number	M7100MD
Description	MDP 380V-480V with GFCI/RCD
Mains Input Breaker, CB1	200A
Gradient PDU Breaker, CB2	200A
System PDU Breaker, CB3	60A
Cryo Compressor Breaker, CB4	25A

The labeled connections shown in [Figure 2-20 GE HealthCare supplied Main Disconnect Panel \(MDP\) Setup for M7100MD on page 48](#) can accept the range of standard stranded conductors shown in the tables below. All wire types, color, and sizing are to be selected in accordance with governing electrical codes.

Table 2-12 GE HealthCare Supplied MDP - Range of Standard stranded Conductors Accepted for M7100MD

Item	Phase		Ground	
	sq mm	AWG/kcmil	sq mm	AWG/kcmil
A	25-150	4-300	16-185	6-350
B	6-120	10-250	16-150	6-300
C	16-120	6-250	16-185	6-350
D	2.5-50	14-1/0	16-150	6-300
E	6-35	10-2	4-35	12-2
F	2.5-10	14-8	2.5-25	14-4
G	2.5-6	14-10	2.5-6	14-10
H	0.5-4	20-12		

2.11.3 Customer-supplied Main Disconnect Panel (MDP) Requirements (exempt countries only*)

**NOTE**

* The requirements listed below apply only to exempt countries. Please contact your GE HealthCare Project Manager of Installation (PMI) for the list of exempt countries.

WARNING**PERSONNEL INJURY OR EQUIPMENT DAMAGE**

Customer supplied MDP must have correctly sized wires and rated components to meet the MR System Power Requirements.

**NOTE**

Refer to [8.5 Sample control schematic for customer-supplied MDP on page 132](#).

1. MDP shall provide Auto-Restart to the Cryocooler Compressor.
2. Manual Restart Capability
 - 2.1. The MDP shall disconnect the ISC circuits upon power loss.
 - 2.2. The MDP shall require a manual restart on the ISC circuits when power is reapplied after an outage.
3. Emergency Off Circuit
 - 3.1. The MDP shall have an emergency off control circuit that disables power to the entire MR System.
 - 3.2. The emergency off circuit shall be actuated by a push button on the panel, and shall also be capable of being actuated by remotely located push button(s).
 - 3.3. Manual reset of the emergency off circuit shall be required to restore power to the entire system.
4. The MDP shall include four breakers, as specified in [Figure 2-21 Customer-supplied MDP MR System Main Disconnect Panel \(MDP\) Setup on page 51](#) and [Table 2-13 Customer Supplied MDP](#)

- [Required Breaker Size on page 51](#). Output breakers will feed the PDU (located in the Integrated Systems Cabinet [ISC]) and Cryocooler Compressor (located in the Integrated Cooling Cabinet [ICC]).

5. Lock-out/Tag-out:
 - 5.1. The MDP shall provide single point lock-out/tag-out for the entire system and a means to lock-out/tag-out each output breaker independently.
 - 5.2. The lock-out/tag-out feature shall accommodate a standard sized lock hasp.
 - 5.3. The lock-out/tag-out features shall be accessible from the outside of the panel, without the need to open the panel door(s).
6. The MDP shall have a Power ON indicator (Green light) on the panel.
7. The MDP shall meet national/local regulations.
8. The MDP shall provide terminations for all grounds entering, leaving and residing within the panel.
9. The MDP shall provide terminations of appropriate size for all power wiring entering and leaving the panel. Refer to [Figure 2-21 Customer-supplied MDP MR System Main Disconnect Panel \(MDP\) Setup on page 51](#). All wire types, color, and sizing are to be selected in accordance with governing electrical codes.

Figure 2-21 Customer-supplied MDP MR System Main Disconnect Panel (MDP) Setup

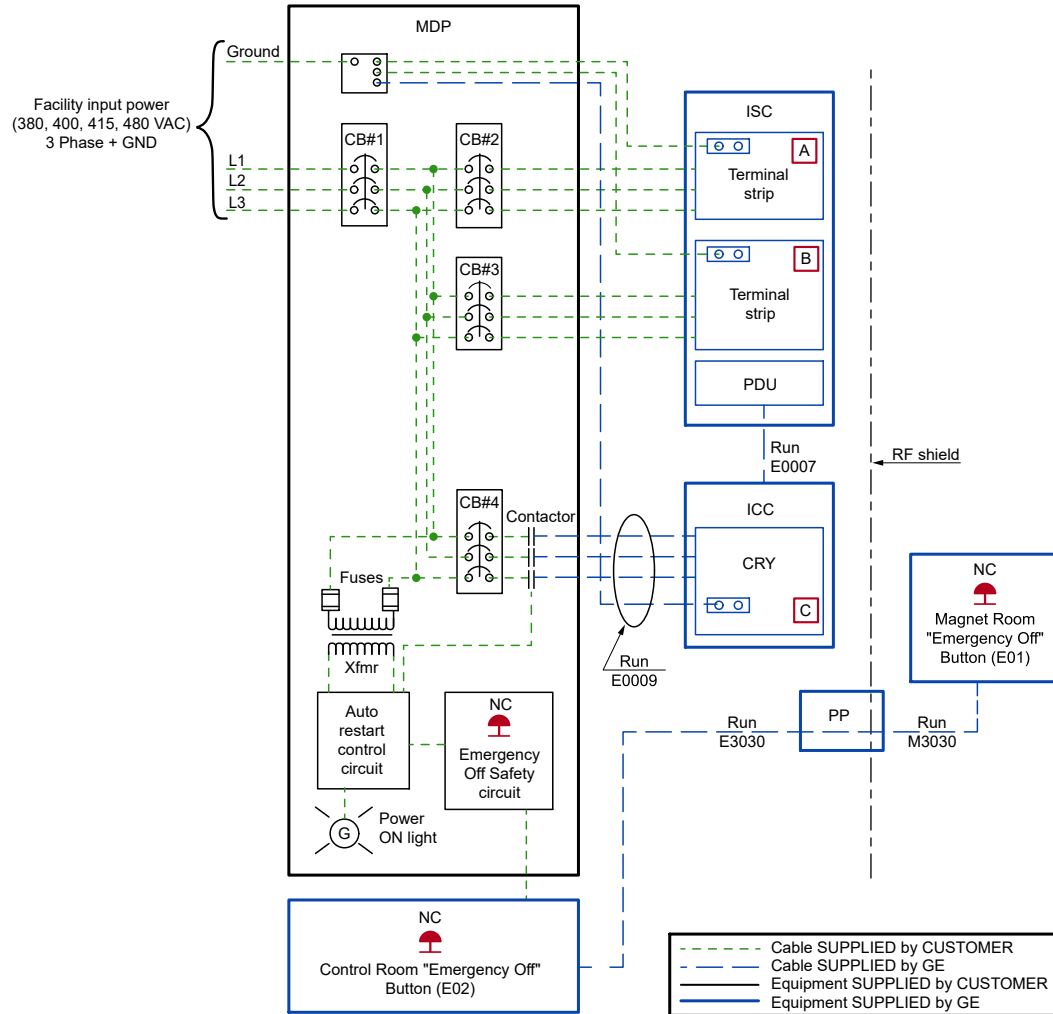

Table 2-13 Customer Supplied MDP - Required Breaker Size

Circuit Breaker	Breaker Size
Mains Input Breaker, CB1	200A minimum
Gradient PDU Breaker, CB2	200A
System PDU Breaker, CB3	60A
Cryo Compressor Breaker, CB4	25-30A

Table 2-14 Customer Supplied MDP - Range of Standard Stranded Conductors Accepted

Item	Phase		Ground	
	sq mm	AWG/kcmil	sq mm	AWG/kcmil
A	16-120	6-250	16-185	6-350
B	6-35	10-2	4-35	12-2
C	2.5-6	14-10	2.5-6	14-10

2.11.4 Emergency Power Backup Specifications (Optional)

The following facility backup power is recommended for continuous operation of the cryocooler compressor and Magnet Monitor:



NOTE

If the compressor must operate on emergency backup power, it still requires chilled water defined in the [2.10.2 Requirements for Emergency Backup Facility Coolant \(Optional\)](#) on page 41.

- Dedicated, single power supply to the compressor
- Magnet Monitor emergency power (110V / 220V, 3A). Refer to [Magnet Monitor \(MON\) Requirements and Specifications](#) on page 92.
- Emergency Off Circuit (E-Off) for the emergency backup to the compressor. LOTO is required for the power source between the generator and compressor.
- A transfer switch to remove the primary power source from the compressor when in emergency backup power mode.

Table 2-15 Specifications for Emergency Power to Cryocooler Compressor

Parameter	Requirements
Power Line Voltage	AC 380, 400, 415V ($\pm 10\%$) / 50 Hz, 3 phase (3 Wire + Ground) AC 480V ($\pm 10\%$) / 60 Hz, 3 phase (3 Wire + Ground) Commercial Power Source <div style="text-align: center;"> <p>WARNING</p>  <p>Do not use an inverter for the main power source.</p> </div>
Operating Current	Max. 13A (Both 50 and 60 Hz)
Starting current	75 / 80 A (50 / 60 Hz)
Maximum Fuse or Circuit Breaker Size	30A
Power Requirement	Minimum 9 kVA Note: The manufacturer recommends a connection capable of 12 kVA.
Power Consumption	Max. 8.3 kW / Steady State 7.5 kW at 60 Hz Max. 7.2 kW / Steady State 6.5 kW at 50 Hz

2.12 MR System Shipping and Receiving



(Applies to all subsections within this section)



IMPORTANT

All shipping dimensions and weights are approximate and may vary based on ship-to location, required rigging, or other requirements. Some shipping or access routes may have requirements in addition to those listed in this section. Contact the GE HealthCare Project Manager of Installation (PMI) to verify magnet shipping, rigging, and access.

2.12.1 Receiving Requirements

1. The customer must provide an area for unloading system components from the truck and delivering to the MR suite



NOTE

Contact GE HealthCare project manager for magnet handling document to be used by rigging companies.

2. The customer is responsible for ensuring:
 - 2.1. All floors along the route will support the weight of the magnet (GE HealthCare recommends a structural analysis)
 - 2.2. Doors or other openings are sufficiently wide to allow passage
 - 2.3. Sufficient room is provided for any required rigging tools

2.12.2 Facility Delivery Route Requirements

The following table lists the delivery dimensions of system components. Upon delivery, verify the component dimensions and weight. The delivery route must be planned to accommodate the dimensions listed.

Table 2-16 Delivery Route Requirements

Component	Width		Depth		Height		Weight		Notes
	mm	in.	mm	in.	mm	in.	kg	lb.	
Magnet	See Table 2-17 MR System Component Shipping Specifications on page 54 .								
Cryogen	Dimensions vary depending on dewar type used. Verify with cryogen supplier.								
ISC 1	602 With dolly: 1212	23.7 With dolly: 47.7	978	38.5	2001	78.8	1034 With dolly: 1116	2279 With dolly: 2460	Cabinets must be raised to remove the pallet but may be lowered almost to floor level while moving. For moving a short distance (for example, from outside the equipment
ISC 2	1362 With dolly: 1972	53.6 With dolly: 77.6	878 With dolly: 986	34.6 With dolly: 38.8	2001	78.8	1025 With dolly: 1107	2260 With dolly: 2441	

Table 2-16 Delivery Route Requirements (Table continued)

Component	Width		Depth		Height		Weight		Notes
	mm	in.	mm	in.	mm	in.	kg	lb.	
ICC	1100 With dolly: 1710	43.3 With dolly: 67.3	842	33.1	1970	77.6	560 With dolly: 642	1235 With dolly: 1415	room across the door to the inside), the equipment can be moved on its casters.

2.12.3 MR System Component Shipping Specifications

MR System component shipping dimensions and weight are listed below:

Table 2-17 MR System Component Shipping Specifications

Component	W x D x H		Weight		Notes
	mm	in.	kg	lb.	
PM Magnet with cryogenics, partial Quiet Technology Enclosure installed	2450 x 1938 x 2400	96.46 x 76.30 x 94.49	5018	11063	Domestic - Tarp
PM Magnet (Crated for International Shipping)	2438 x 2896 x 2438	96 x 114 x 96	5967	13155	International - crate/pallet
Magnet Accessory Equipment	1219 x 1219 x 711	48 x 48 x 28	182	400	Crate
Cryocooler Compressor	660 x 711 x 1067	26 x 28 x 42	125	275	Pallet with box cover
Enclosure	2245 x 2186 x 1851	88 x 86 x 73	713	1572	Crate
Patient Table	2616 x 1067 x 914	103 x 42 x 36	499	1097	Pallet
Integrated System Cabinet (ISC) 1	878 x 1126 x 2265	35 x 44 x 89	1180	2602	Pallet plus crate
Integrated System Cabinet (ISC) 2	1529 x 1005 x 2295	60 x 40 x 90	1157	2551	Pallet plus crate
Integrated Cooling Cabinet (ICC)	1338 x 952 x 2180	53 x 38 x 86	716	1575	Crate
Penetration Panel	1725 x 635 x 615	68 x 25 x 24	74	164	Box
Operator Workspace Cabinet	600 x 900 x 780	24 x 35 x 31	110	243	Wood pallet with cardboard cover
Operator Workspace Display	686 x 838 x 686	27 x 33 x 27	9	19	Box
Operator Workspace Table	1041 x 1372 x 381	41 x 54 x 15	75	165	Box

Figure 2-22 Magnet Dimensions (as Shipped) for PM Magnet

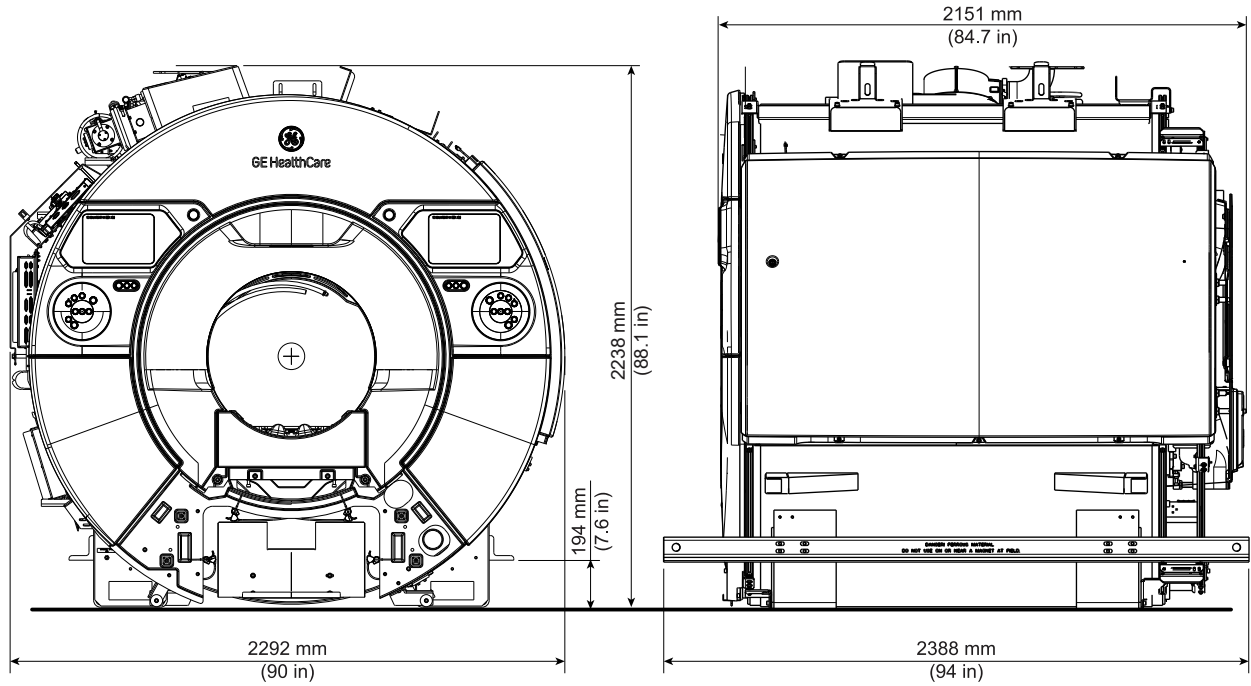

Table 2-18 MR System Component Replacement Shipping Specifications

Component	Component Location	W x D x H		Weight	
		mm	in.	kg	lb.
1-piece Bridge	Magnet Room	770 x 2570 x 470	30.3 x 101.2 x 18.5	107	235
Replacement RF Body Coil	Magnet Room	965 x 991 x 1981	38 x 39 x 78	156	345
Replacement ZRMw Gradient Coil Assembly on a Shipping Cradle/Cart	Magnet Room	910 x 2444 x 1499	35.8 x 96.2 x 59	1469	3239
Gradient Power Supply	Equipment room (front of ISC)	750 x 1026 x 437	29.5 x 40.4 x 17.2	85	179
Gradient Cooling Unit (GCU)	Equipment room (front of ICC)	920 x 605 x 1445	36.2 x 23.8 x 56.9	145	319
Cabinet Cooling Unit (CCU)	Equipment room (front of ICC)	920 x 705 x 1550	36.2 x 27.8 x 61.0	196	431
Gradient Coil Replacement Tool Kit Crate	At site near magnet room	787 x 2184 x 952	31 x 86 x 37.5	340	750



NOTE

The dimensions and weights listed for the components in [Table 2-18 MR System Component Replacement Shipping Specifications](#) on page 55 include packaging.

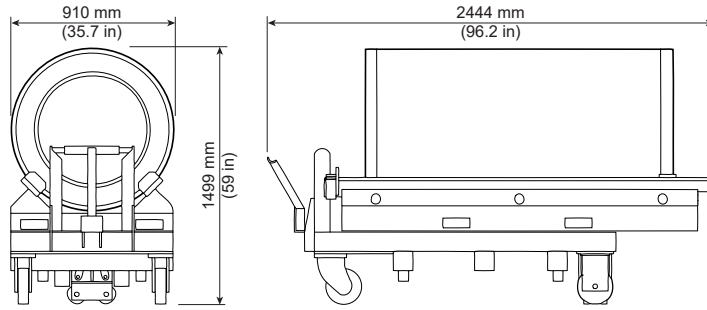
Figure 2-23 Gradient Coil Cart

2.12.4 Temperature and Humidity Storage Requirements

MR systems and components must be stored within the environmental requirements listed below.



NOTE

Some equipment is liquid-cooled. After coolant is added, the equipment must be kept from freezing. Phantoms and the coolant itself must also be kept from freezing.

Room	Temperature		Humidity	
	Range °C (°F)	Change °C/Hr (°F/Hr)	Relative % (Non-condensing)	Change %/Hr
System	-30 — 50 (-22 — 122)	20 (68)	10 — 80	30
Surface Coil	-30 — 50 (-22 — 122)	20 (68)	10 — 95	30

3 Magnet Room

3.1 Magnet Room Introduction



The Magnet Room is best understood as a series of layers, or “rooms within a room.” Each of these rooms has a specific function and associated requirements. All requirements in this chapter must be followed to ensure safe and correct operation of the MR System.

1. The Magnetic shielded room contains the MR Magnet fringe field within a confined space. A site survey is required to determine magnet shield requirements (not all sites require magnetic shielding). Because of the added cost of magnetic shielding, room location should be carefully considered.
2. The Acoustic room is a layer used to help attenuate the noise produced during a scan. An acoustic engineer is strongly recommended to assess the environment.
3. The RF shielded room is critical to the correct MR System operation. RF shielding prevents interaction of external RF radiation with MR System operation and it also prevents MR System RF radiation from interfering with external systems, such as aircraft control. Special care must be used when installing all fixtures penetrating the RF shield (for example, vents, electrical conduit, penetration panels) to ensure the integrity of the RF shield is maintained. Refer to *RF Shielded Room Requirements*, 5850260-1EN.
4. The Finished room includes the wall coverings, ceiling tile, ceiling grid, other fixtures, Magnet (MAG) and Patient Table (PT). When planning the finished room, ensure the following:
 - 4.1. All building codes are met (such as maintaining egress routes).
 - 4.2. Items which may generate or create RF interference (including fluorescent lighting) are not allowed for installation within the Magnet Room.
 - 4.3. Customer is responsible for the selection and installation of all locally required safety devices (for example, smoke detectors, oxygen monitors, and so on).
 - 4.4. Smoke detectors should be located outside of the Magnet Room (for example, within the return air duct) whenever possible. If code does not allow this, use only simple two wire non-addressable smoke detectors in the Magnet Room.
 - 4.5. Ferrous or metallic items which could become projectiles when the magnet is installed (including wall coverings, ceiling tile, ceiling grid, or other fixtures) are not used or are correctly secured.

Figure 3-1 Magnet Room Layers

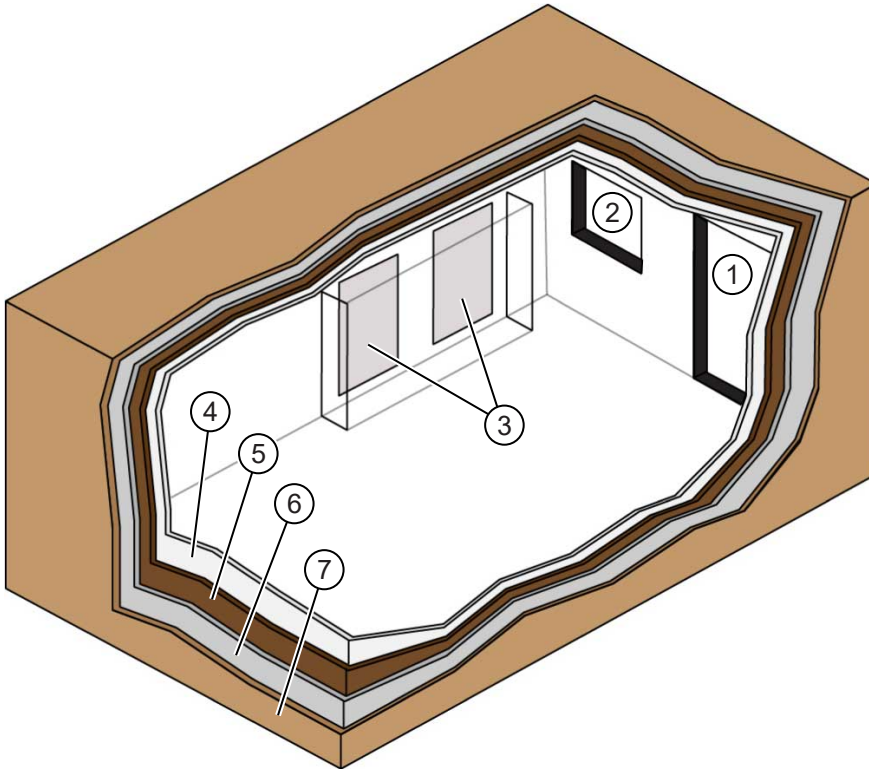

Item	Description	Item	Description
1	Door	2	Window
3	Penetration wall(s)	4	Finished room
5	RF shielding	6	Acoustic barrier
7	Magnetic shielding	-	-

**NOTE**

The sequence of the room layers can vary based on siting needs.

3.2 Magnet Room Structural Requirements



This section lists the structural requirements that must be considered when performing site evaluation and planning of the Magnet Room.

3.2.1 Overview



1. When preparing a building plan or evaluating a potential site for an MR System, take care to ensure the MR suite will not interact with the surrounding environment (that is, magnetic, acoustic, environmental steel, and vibration).
2. The customer is responsible for vibration testing required to verify suitability of a proposed site. All test results and any questions regarding testing, results, or analysis must be forwarded to the GE HealthCare Project Manager of Installation (PMI).

3.2.2 Environmental Steel Limits



A static magnetic field extends in a three-dimensional space around the magnet isocenter. Environmental steel within the static magnetic field affects the uniformity (or homogeneity) of the field. Field uniformity is critical to both image quality and chemical shift analysis (spectroscopy). An analysis of the environmental steel is required within a 2.5 m (8.2 ft.) spherical radius of the magnet isocenter. Environmental steel includes ferrous pipes, beams, concrete rebar, or any other structural steel in the floors, walls, or ceiling.

The following floor items must be limited per [Table 3-1 Steel Mass Limits to Magnet Isocenter \(3 x 3 m \(10 x 10 ft.\) Area Under Magnet\) on page 61](#).

1. Non-movable steel construction material such as rebar and metal decking
2. Existing or proposed RF/magnetic shielding or shim plates
3. [Table 3-1 Steel Mass Limits to Magnet Isocenter \(3 x 3 m \(10 x 10 ft.\) Area Under Magnet\) on page 61](#) defines the limits of use as a guideline to help the customer understand allowable amounts of ferrous rebar, steel decking, or other components as they design the MR suite and Magnet Room floor structure.
4. The customer must provide detail defining ferrous material below the magnet to the Project Manager so the GE HealthCare MR Siting and Shielding (MRSS) team can review for compliance.

Table 3-1 Steel Mass Limits to Magnet Isocenter (3 x 3 m (10 x 10 ft.) Area Under Magnet)

Limits Of Steel Mass kg/m ² (lb./ft ²)	Distance Below Top Surface Of Floor mm (in.)
0 (0)	0-76 (0-3)
9.8 (2)	76-127 (3-5)
14.7 (3)	127-254 (5-10)
39.2 (8)	254-330 (10-13)
98.0 (20)	330+ (13+)

3.2.3 Vibration Requirements



Excessive vibration can affect MR image quality. Vibration testing must be performed early in the site planning process to ensure vibration is minimized. Both steady state vibration (exhaust fans, air conditioners, pumps, and so on) and transient vibrations (traffic, pedestrians, door slamming, and so on) must be assessed (see [Figure 3-2 Magnet Steady State Vibration Specifications for PM magnet on page 62](#)). Specific requirements for vibration mitigation, include:

1. The Magnet (MAG) cannot be directly isolated from vibration. Any vibration issue must be resolved at the source.
2. MR Suite HVAC must have vibration isolation.
3. A vibration analysis must be performed at the proposed site with the results (and any mitigation) forwarded to the GE HealthCare Project Manager of Installation (PMI). See the [8.2 MR Site Vibration Test Guidelines on page 124](#).
4. A transient vibration test must only be performed after a steady-state test has been performed and all steady-state sources of vibration have been mitigated.
5. Transient vibration levels above the specified limits in the [8.2 MR Site Vibration Test Guidelines on page 124](#) must be given to the PMI for review.
6. Any transient vibration that causes vibration to exceed the steady-state level must be mitigated.
7. The vibration test consultant must account for non-mechanically induced signals such as test equipment instabilities, thermal drift or RF interference.

Figure 3-2 Magnet Steady State Vibration Specifications for PM magnet

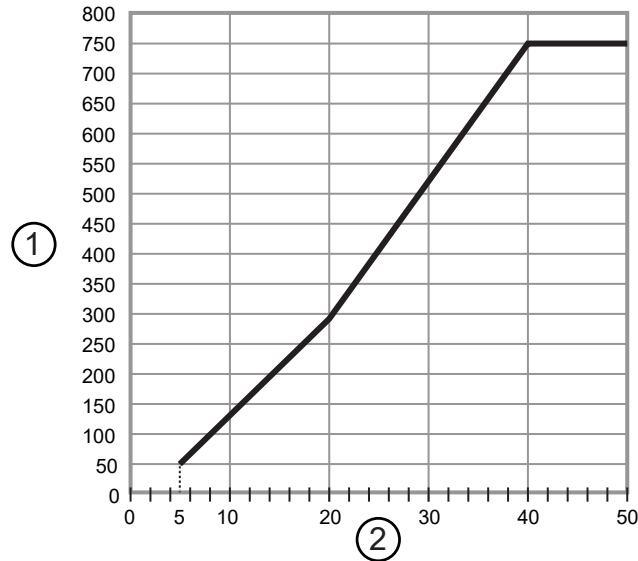

Item	Description
1	Acceleration ($g \times 10^{-6}$) (RMS) above ambient baseline
2	Excitation frequency (Hz)

3.3 Magnetic Shielded Room Requirements



Magnetic shielding prevents interaction between the magnet and nearby sensitive devices. Because of the added cost of magnetic shielding, room location should be carefully considered. All sites, including upgrade sites, must be evaluated for magnetic shielding requirements. Existing magnetic shielding at an upgrade site may not be sufficient for the new system. Contact the GE HealthCare Project Manager of Installation (PMI) to request a site evaluation.

See [MR Suite Magnetic Field Specifications on page 24](#) for detailed magnetic proximity limit information.

1. The GE HealthCare Project Manager of Installation (PMI) works with the customer to coordinate the magnetic shielding site evaluation.
2. If required, the GE HealthCare Project Manager of Installation (PMI) coordinates the delivery of the magnetic shielding design.
3. The customer is responsible for installation of all magnetic shielding.
4. If rear wall magnetic shield or steel RF wall is closer than 2500mm (98.4 in.) from isocenter, it should be verified by GE HealthCare PMI.

3.4 Penetration Panel Wall Opening Requirements



1. The Equipment Room and the Magnet Room must share at least one common wall to mount the penetration panel.
2. The penetration panel opening requirements are shown in [Figure 3-3 Penetration Wall Openings on page 64](#).
3. The RF vendor must supply fasteners and nuts (26 each), or wood screws to mount the penetration panel to the GE HealthCare-supplied mounting blocks.



NOTE

The length of the fasteners should be based on the thickness of the RF Wall.

4. RF shielding in the Magnet Room walls must completely wrap around all edges of the penetration wall openings and continue through the openings to the inside of the Equipment Room to provide full shielding continuity with the penetration panel.
5. A minimum of 102 mm (4 in.) is required between the floor and the bottom of the penetration panel opening to provide clearance for the penetration panel.

Figure 3-3 Penetration Wall Openings

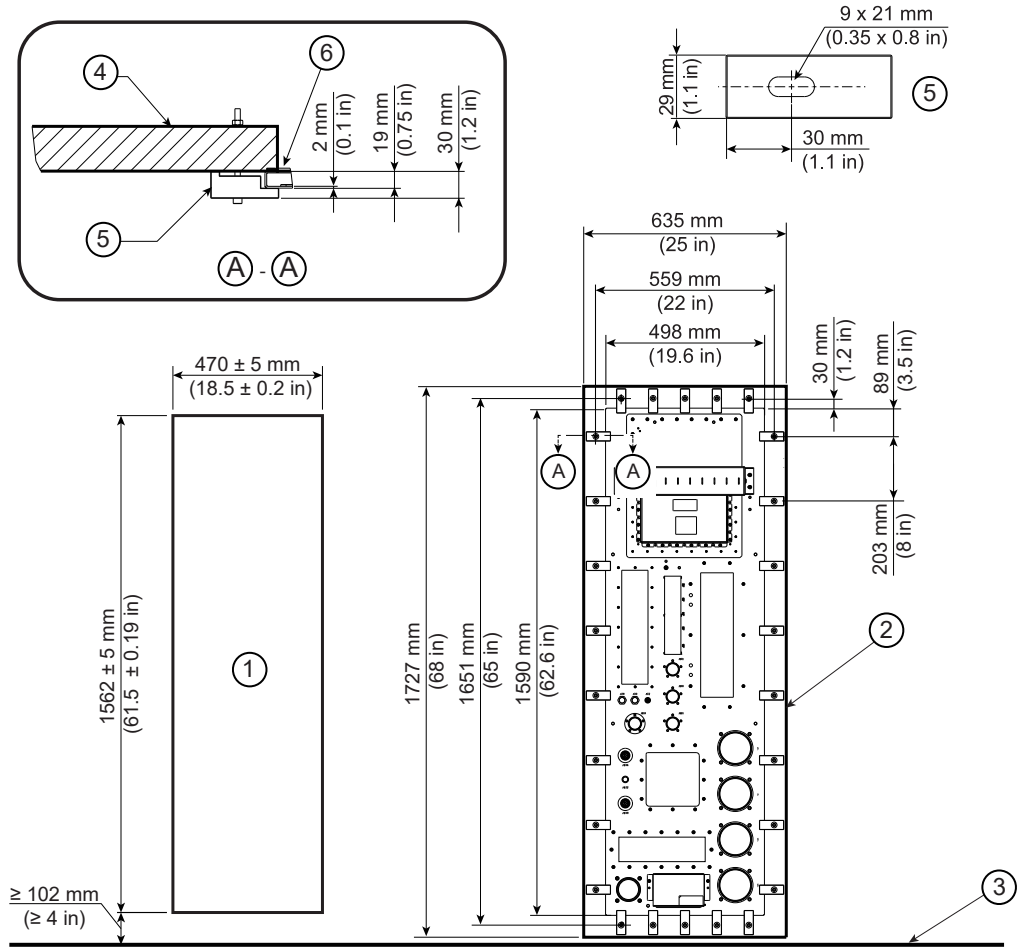

Item	Description	Item	Description
1	Wall opening	4	RF Shield Magnet Room
2	Clearance required around opening for mounting Penetration Panel (82.6 mm (3.25 in))	5	GE HealthCare-supplied Mounting block (26 total)
3	Finished floor on Equipment Room side of RF Shield	6	Penetration Panel

3.5 Finished Room Requirements

3.5.1 Ferrous Materials in the Magnet Room



1. Non-ferrous (non-metallic) materials or components should be used in the Magnet Room.
2. Ferrous components or material in the Magnet Room that could be removed for servicing, cleaning, or replacement must be secured to prevent the ferrous material from becoming a projectile (ferrous components or material must also be identified as ferrous to prevent untrained personnel from working on the ferrous material while the magnet is energized).

3.5.2 Walls



Refer to *Acoustic Room Details*, 5850262-1EN. Hard, bare wall surfaces may create a harsh Magnet Room acoustic environment due to reflection of sound waves. Finished walls with acoustic properties can reduce reflected noise.

1. GE HealthCare recommends finished walls to protect the RF shielding.
2. Walls and any millwork, cabinets, storage areas, acoustic coverings, and so on, must remain outside the minimum service area.
3. A metallic electrical conduit inside walls and ceilings may be used. Conduit for receptacles must be metallic.

3.5.3 Magnet Preinstallation Markings



For correct cryogen venting, the magnet vent adaptor must align correctly with the ceiling vent when the magnet is installed.

1. The magnet isocenter position must be clearly marked, and the marking must be identifiable throughout construction.



NOTE

If there is no ceiling grid in the room, we recommend to also mark the magnet isocenter location on the ceiling. This can serve as a reference for positioning a new vent pipe, or can be used to reproduce the floor markings if they become lost during construction.

Refer to *Magnet Room Venting Requirements*, 5850263-1EN for the location of the magnet vent.

2. If no ceiling vent pipe exists prior to construction, the location of the magnet isocenter and magnet z-axis orientation must be marked on the Magnet Room floor as shown below.

Figure 3-4 Marking Magnet Isocenter (in a Room Without a Vent Pipe)

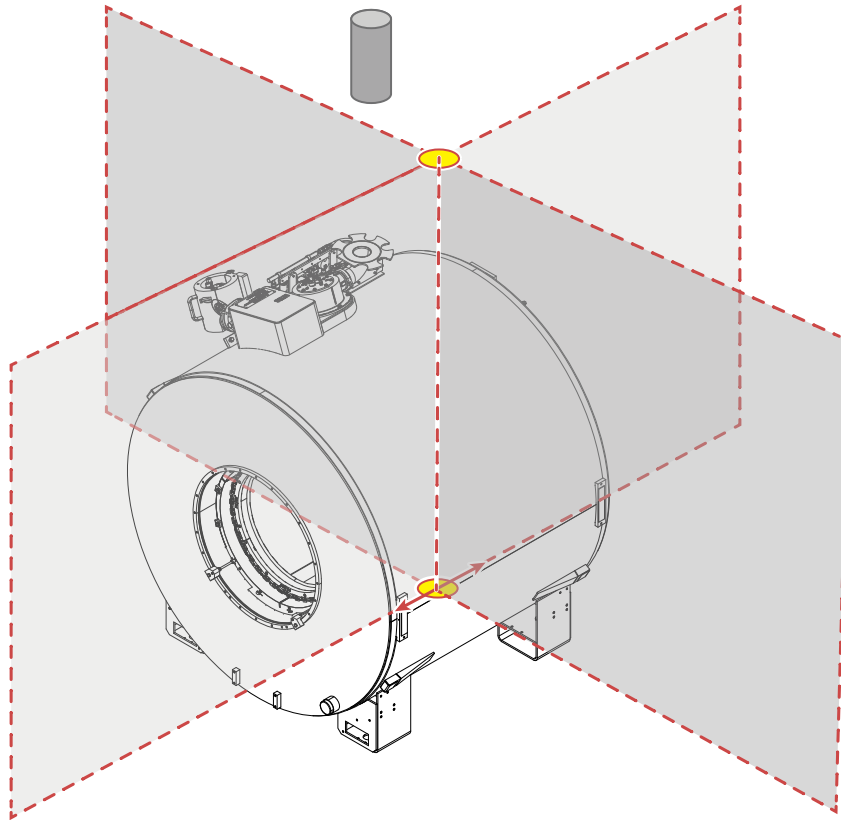
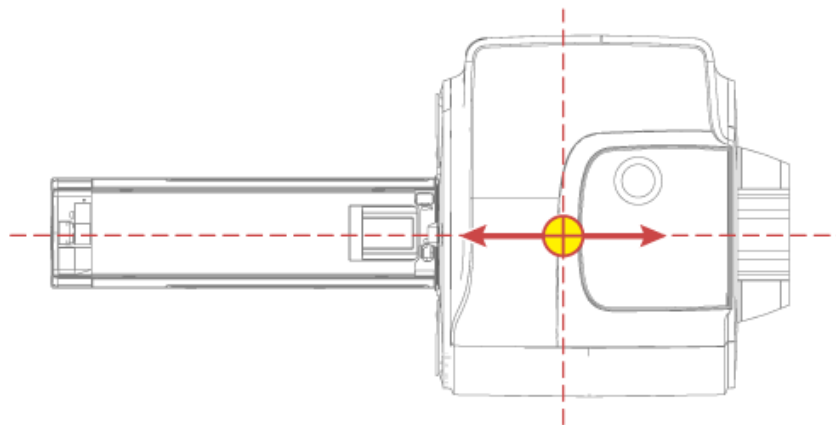

Figure 3-5 Marking the Magnet Isocenter and the Z-Axis Orientation on the Floor



3. If a ceiling vent pipe already exists at the start of construction, the magnet isocenter marking must be correctly aligned relative to the position of the vent pipe. Refer to *Magnet Room Venting Requirements*, 5850263-1EN for the location of the magnet vent.

**NOTE**

We recommend:

- Marking the center of the vent pipe.
- Using a cross line laser or other accurate method to transcribe it to the floor directly below.
- Marking the magnet isocenter relative to the vent pipe marking on the floor. The positioning template (5810898 or 5810898-2) can be used as a marking aid.

Figure 3-6 Marking the Center of the Vent Pipe

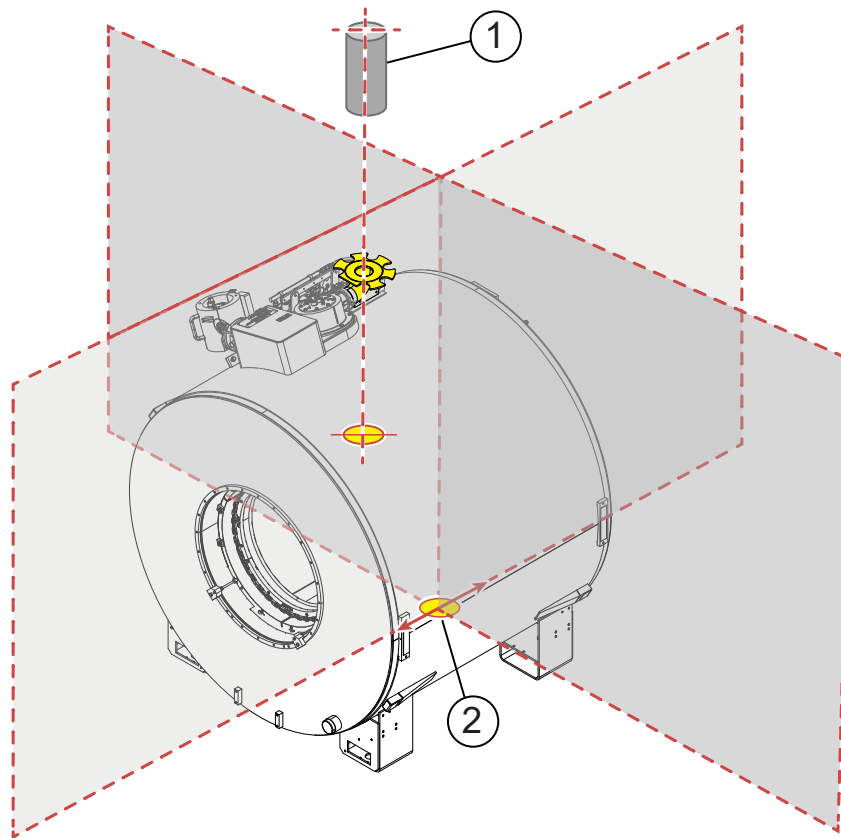

Item	Description
1	Vent center
2	Magnet isocenter

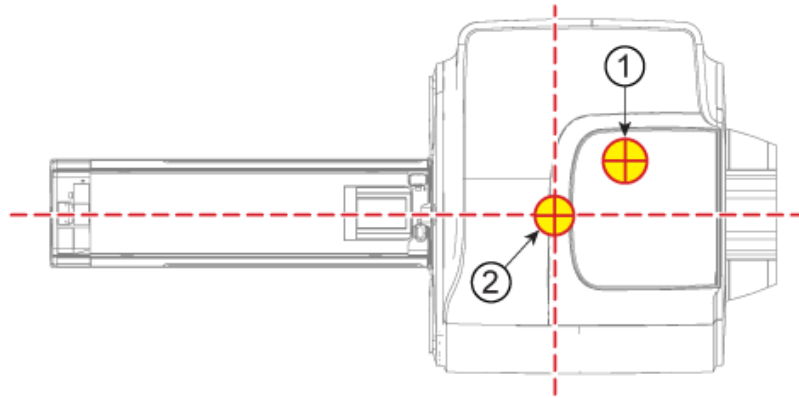
Figure 3-7 Marking the Vent Pipe and Magnet Isocenter on the Floor

Item	Description
1	Vent center
2	Magnet isocenter

3.5.4 Penetration Panel Closet



1. An enclosure (that is, the penetration panel closet) must be provided to restrict access to the penetration panel(s) and for storage of excess interconnections.
 - 1.1. The penetration panel closet must meet the minimum penetration panel closet outline as shown in [3.5.5 Penetration Panel Closet Specifications on page 70](#).
 - 1.2. The penetration panel closet must have a mechanical locking mechanism to restrict access to the penetration panels.
 - 1.3. The penetration panel closet may be expanded to provide an area for excess cable storage with the following requirements:
 - 1.3.1. Excess cable must not be stored within the minimum closet service area.
 - 1.3.2. Excess cable must not interfere with access or servicing of the Penetration Panel (PP).
 - 1.3.3. The area within the penetration panel closet to store the cable should be sized to accept a 660 mm (26 in.) cable loop (2x the minimum bend radius of the largest cable).
 - 1.3.4. Refer to [7.1.5 Storage Requirements for Excess Gradient Cable on page 108](#) for additional excess cable storage requirements.
 - 1.4. The penetration panel closet must allow free air exchange of 680 m³/hour (400 cfm) between the Magnet Room and penetration panel closet for MR System blowers. Airflow may be achieved through door louvers or other openings in the penetration panel closet that meet all other penetration panel closet requirements.
 - 1.5. The primary source of airflow must be from the Magnet Room. Openings into the area above a false ceiling or other storage areas should be minimized.

3.5.5 Penetration Panel Closet Specifications

- Minimum Closet Depth: 650 mm (25.6 in)
- Minimum Closet Width: 903mm (35.6in)
- Minimum Closet Height: 1900 mm (74.80 in)

NOTE
 If the closet depth is less than 914 mm (36 in), the closet must have door(s) configured to clear the service area for the Penetration Panel.

NOTE
 Minimum closet specifications do not account for storage space for excess gradient cable. Refer to [7.1.5 Storage Requirements for Excess Gradient Cable on page 108](#) for additional excess cable storage requirements.

Figure 3-8 Minimum dimensions of closet in the Magnet Room

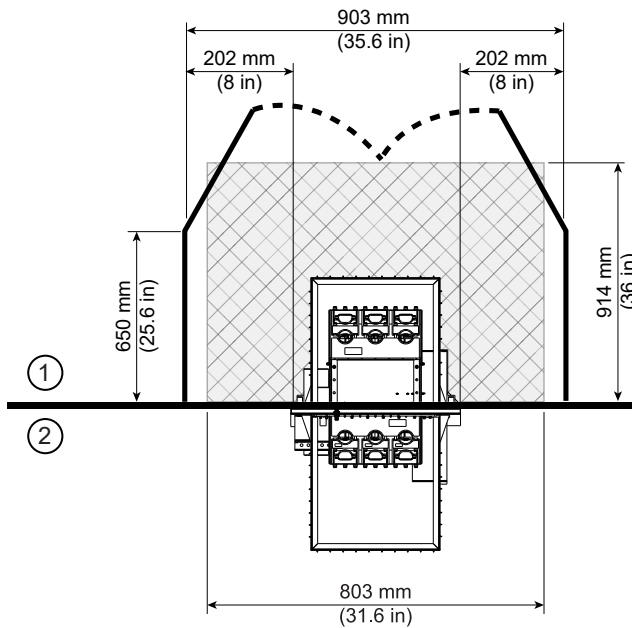

Item	Description
1	Magnet Room
2	Equipment Room

3.5.6 Doors, Magnet Access Openings, and Patient Viewing Windows



1. The finished opening of the Magnet Room main door must be at least 1092 mm (43 in.) wide to allow for helium dewars and patient tables.
2. Threshold height must not exceed 15 mm (0.6 in.) on both sides of the door with a maximum 10-degree threshold inclination.
3. IEC requires the patient, while in the bore, be in full view of the operator for routine monitoring of the patient.



NOTE

- GE HealthCare recommends using a window, although other means (for example, camera and video display) may be used as long as all IEC requirements are met.
 - The recommended dimensions for the patient viewing windows are 1219 mm wide x 762 mm high (48 in. wide x 30 in. high).
 - The recommended distance from the bottom edge of the patient viewing window to the finished floor is 1067 mm (42 in.).
4. The magnet delivery requires an opening into the room to allow access for the magnet delivery, rigging, and personnel access.

3.5.7 Finished Ceiling



1. The customer is responsible for the finished ceiling.
2. The finished ceiling grid must be non-ferrous.
3. Ceiling preparation should be completed prior to magnet delivery. See [Figure 3-9 Cable Concealment Kit Ceiling Opening Dimensions \(Top View\)](#) on page 72 for ceiling opening dimensions.



NOTE

- No special frames are necessary for the system. The cable concealment kit is mounted on the top of the magnet.
- The space above the cable concealment opening must be clear of any obstructions, up to a height of 2794 mm (110 in.) from the finished floor, for cables to be routed to the magnet. Refer to [7.2.4 Cable Tray Requirements and Examples on page 114](#) for height requirements for the trays that route cables through this opening.

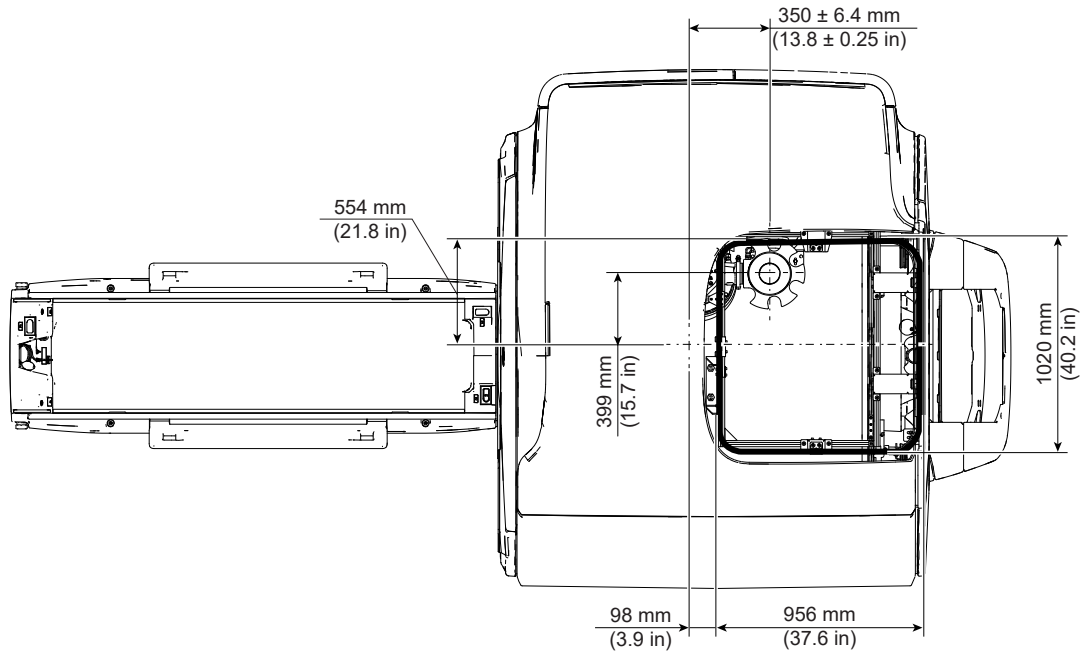
Figure 3-9 Cable Concealment Kit Ceiling Opening Dimensions (Top View)

3.5.8 Magnet Room Floors



1. The finished floor must support the weight of all components throughout operation and service life. This includes the magnet, patient table, and gradient coil replacement cart.



NOTE

For gradient coil replacement, field engineers remove the patient table from the Magnet Room before they move the gradient coil replacement cart into the Magnet Room.

2. The finished floor must be water resistant to protect the subfloor and shielding from water damage.
3. The customer is responsible for providing flooring to prevent ESD (Electrostatic Discharge) buildup to 8 kV for protection of the sensitive MR equipment.
4. Magnet, Enclosure, and Patient Table areas must be flat and level within 3 mm (0.125 in.), with the magnet in place, within the shaded area shown in [Figure 3-10 Magnet Room Floor Levelness Area on page 73](#).

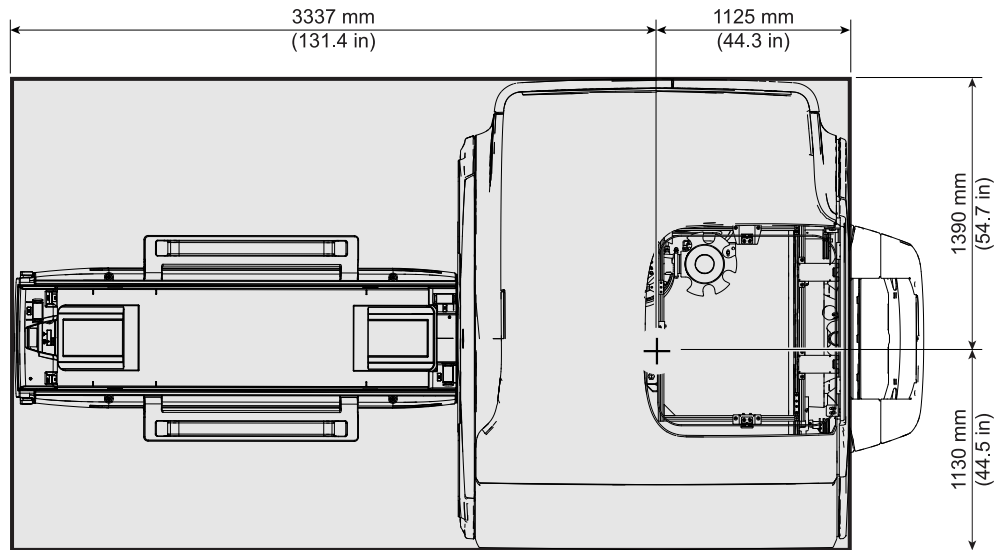
Figure 3-10 Magnet Room Floor Levelness Area

5. The VibroAcoustic Dampening kit for both seismic and non-seismic mounting is included with the magnet shipment. See [Figure 3-11 For PM series magnet only: Magnet Mounting Detail—Patient End is on the Left Side](#) on page 74 for details.
 - Seismic anchors shall have a 76.2 mm (3 in) rebar-free area around the anchor and shall be installed with the assistance of the RF shield vendor.
 - A 102 mm x 102 mm (4 in. x 4 in.) rebar-free area is necessary under the dock/table frame anchor, in the position shown in the figure below.
 - Seismic anchors must be isolated from rebar.
 - For seismic installations, a mounting hardware kit for the magnet feet (M6001AH) is available from GE HealthCare.

**IMPORTANT**

The table dock/table frame anchor hole is drilled only after magnet installation.

Figure 3-11 For PM series magnet only: Magnet Mounting Detail— Patient End is on the Left Side

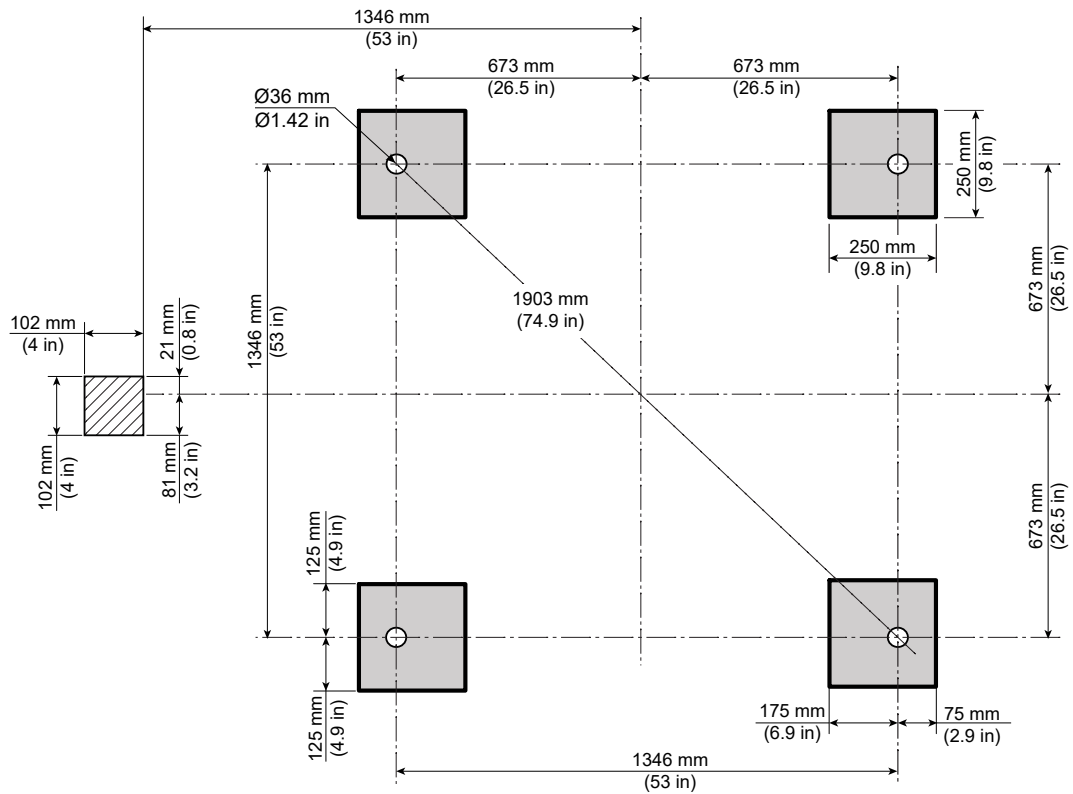

6. Magnet seismic installation preparation: seismic anchor studs must be 1 1/4" in diameter, and 5.75" +/- 0.25" in length above the finished floor.
7. RF shield seams, joints, or overlaps must not be located under the VibroAcoustic mats.

3.5.9 Storage Cabinets



NOTE

GE HealthCare no longer provides a storage solution for system phantoms.

1. The customer shall provide storage for phantoms in the magnet room (for example, a cart, shelving unit or cabinet). Storage needs to be large enough to accommodate system phantoms listed in Table 1-1 of *Customer Site Storage Requirements*, 5182674 (available in the Customer Documentation Portal).
2. The storage solution can not interfere with the magnet room minimum service area.

3.6 Magnet Room Equipment Specifications



(Applies to all subsections within this section)

3.6.1 Magnet (MAG) Assembly Specifications

1. PM Magnet weight, with cryogenics at maximum capacity: 4816 kg (10617 lb).

Figure 3-12 Magnet (MAG) Dimensions

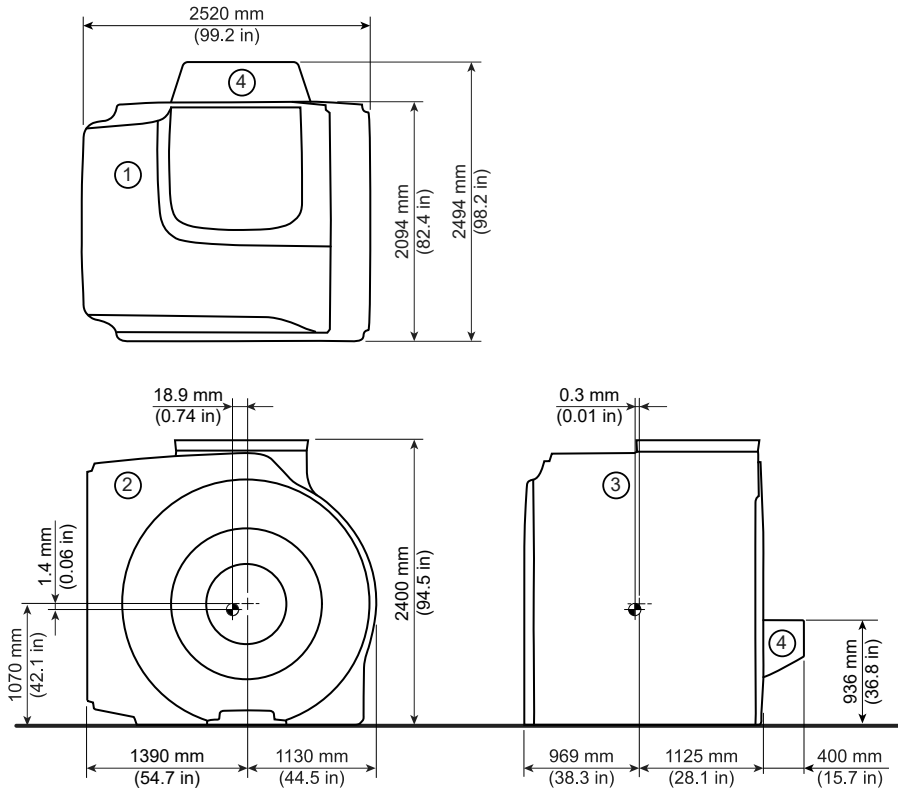

Item	Description	Item	Description
1	Top view	3	Side view
2	Front view	4	Rear bridge

3.6.2 Patient Table (PT) Specifications

1. Detachable eXpress Table weight, empty: 329 kg (725 lb.)
2. Detachable eXpress Table weight, including maximum patient weight of 250 kg (551 lb.) and accessories: 608 kg (1338 lb.)

Figure 3-13 Detachable eXpress Patient Table (PT)

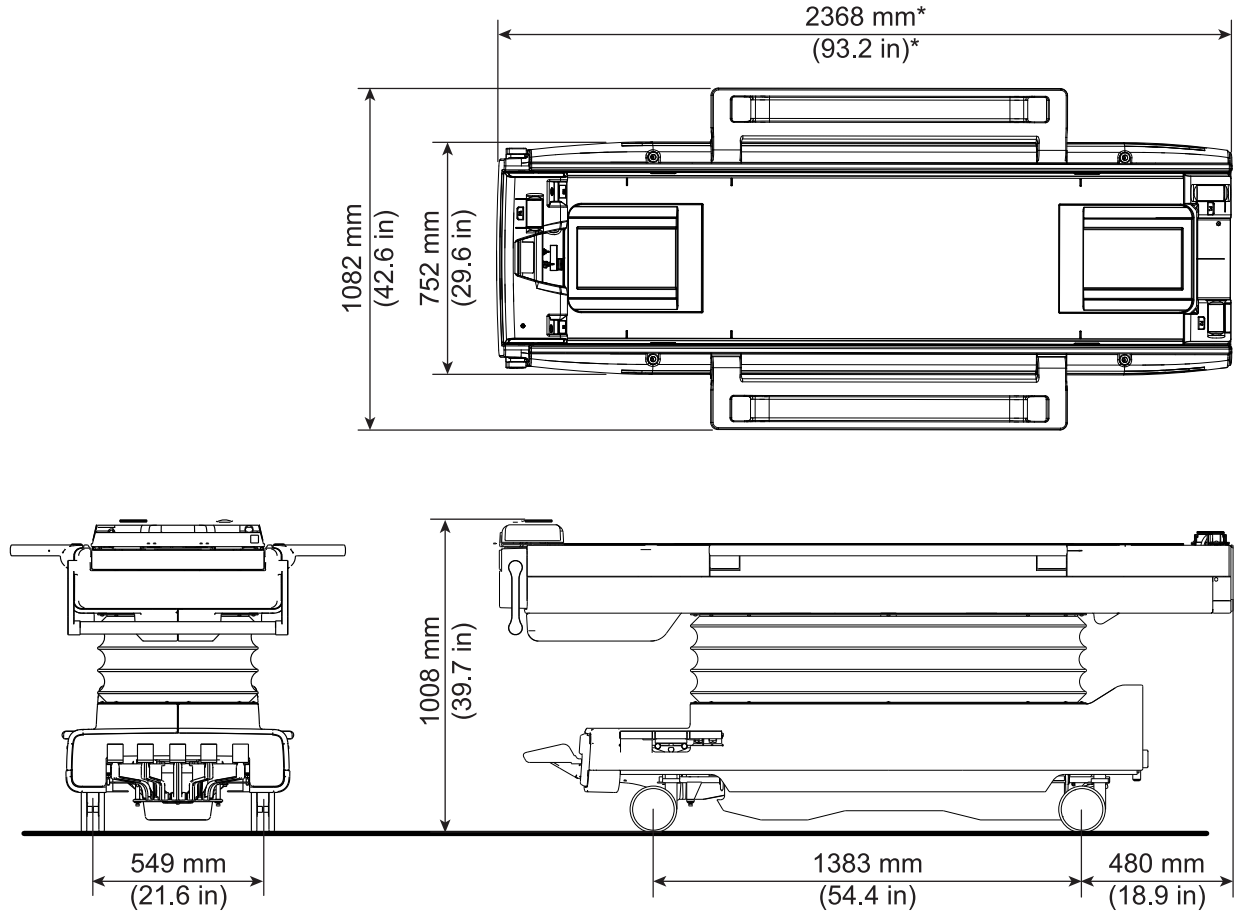

* When the table handle is rotated into its extended position, the length of the table is 2433 mm (95.8 in.)

3.6.3 Magnet Rundown Unit (MRU) Specifications and Requirements

1. Location: The bottom edge of the MRU must be mounted 1524 ± 25 mm (60 ± 1 in.) above the Magnet Room floor near the front of the magnet enclosure.
2. Weight: 3.2 kg (7 lb.)
3. Magnetic Field Limit: 20 mT (200 G)
4. The MRU is installed by the facility contractor.



NOTE

An optional remote MRU may be installed outside the Magnet Room. The remote MRU does not require facility power. For more information, refer to MRU vendor manual.

Figure 3-14 Magnet Rundown Unit (MRU)

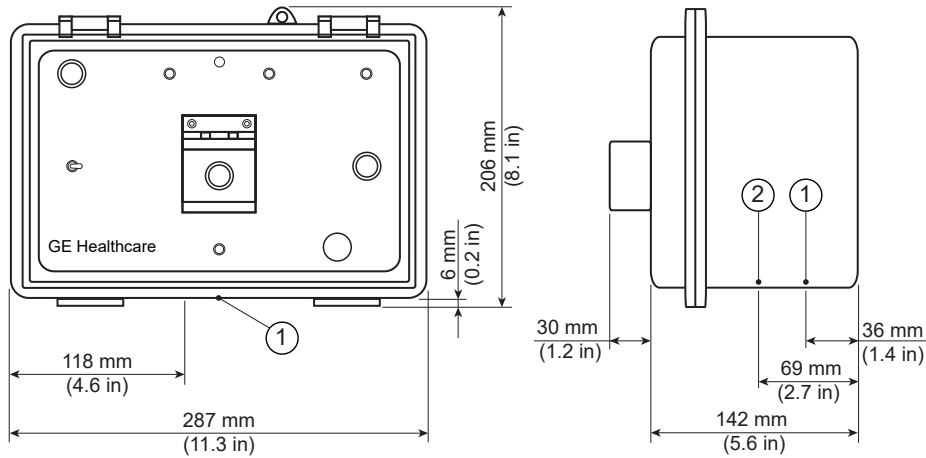

Item	Description
1	Cable access
2	Power access

Figure 3-15 MRU Mounting Pattern

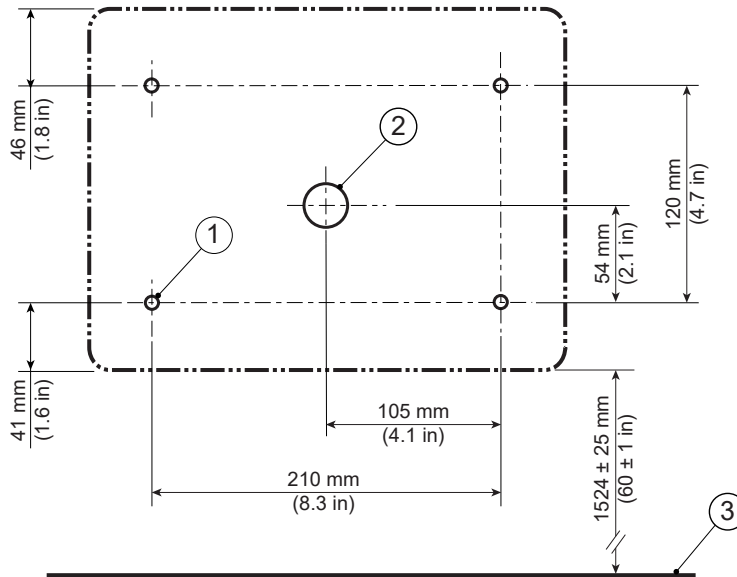

Item	Description	Item	Description
1	7 mm (0.275 in.) diameter mounting hole	3	Finished floor
2	26 mm (1.025 in.) diameter cable access	-	-

3.6.4 Oxygen Monitor Option Sensor Specifications

See [Oxygen Monitor \(OXY\) Option](#) on page 101.

3.7 Magnet Room Lighting Requirements



1. All lighting fixtures and associated components must meet all RF shielded room and RF grounding requirements (for example, track lighting is not recommended due to possible RF noise).
2. All removable lighting fixtures and associated components must be non-magnetic.
3. All lighting must use direct current (the DC must have less than 5% ripple).
4. At least 300 lux must be provided at the front of the magnet for patient access and above the magnet for servicing.
5. Fluorescent lighting must not be used in the Magnet Room.
6. Lighting must be adjusted using a discrete switch or a variable DC lighting controller.
7. SCR dimmers or rheostats must not be used.
8. DC LED lighting may be used if the DC power converter and RF sources are all located outside the Magnet Room RF Shield.



NOTE

LED lighting could cause image quality issues due to RF interference. Make sure a MR-compatible LED lighting solution is chosen.

9. Battery chargers (for example, used for emergency lighting) must be located outside the Magnet Room.
10. LED Lighting or short filament length incandescent bulbs are recommended.
11. Linear lamps are not recommended due to the high burnout rate.

4 Equipment Room

4.1 Equipment Room Overview



(Applies to all sections within this chapter)

1. The vertical distance between the coolant connection points of the ICC and the Gradient Coil must be less than 5 meters (196.8 in.).
2. The ICC and ISC must be located on the same floor.



NOTE

The ICC contains the cryocooler compressor.

The following illustration shows minimum equipment room service clearances. Refer to [MR Suite Minimum Room Size Requirements on page 18](#) for a list of considerations not included in the minimum area dimensions.



NOTE

Colored areas indicate service/installation areas. These areas can overlap as necessary as shown below. See individual component descriptions and room requirements for service area details. Magnet Monitor (MON) can be mounted on the side of the wall near the ICC. Optional equipment is not shown; additional space may be required for options.



NOTE

Refer to [Table 2-18 MR System Component Replacement Shipping Specifications on page 55](#) for the dimensions of the replacement parts. The parts must be able to be positioned in front of the noted cabinet for replacement procedures after the system has been installed.

Figure 4-1 Typical Minimum Equipment Room with Service Clearances

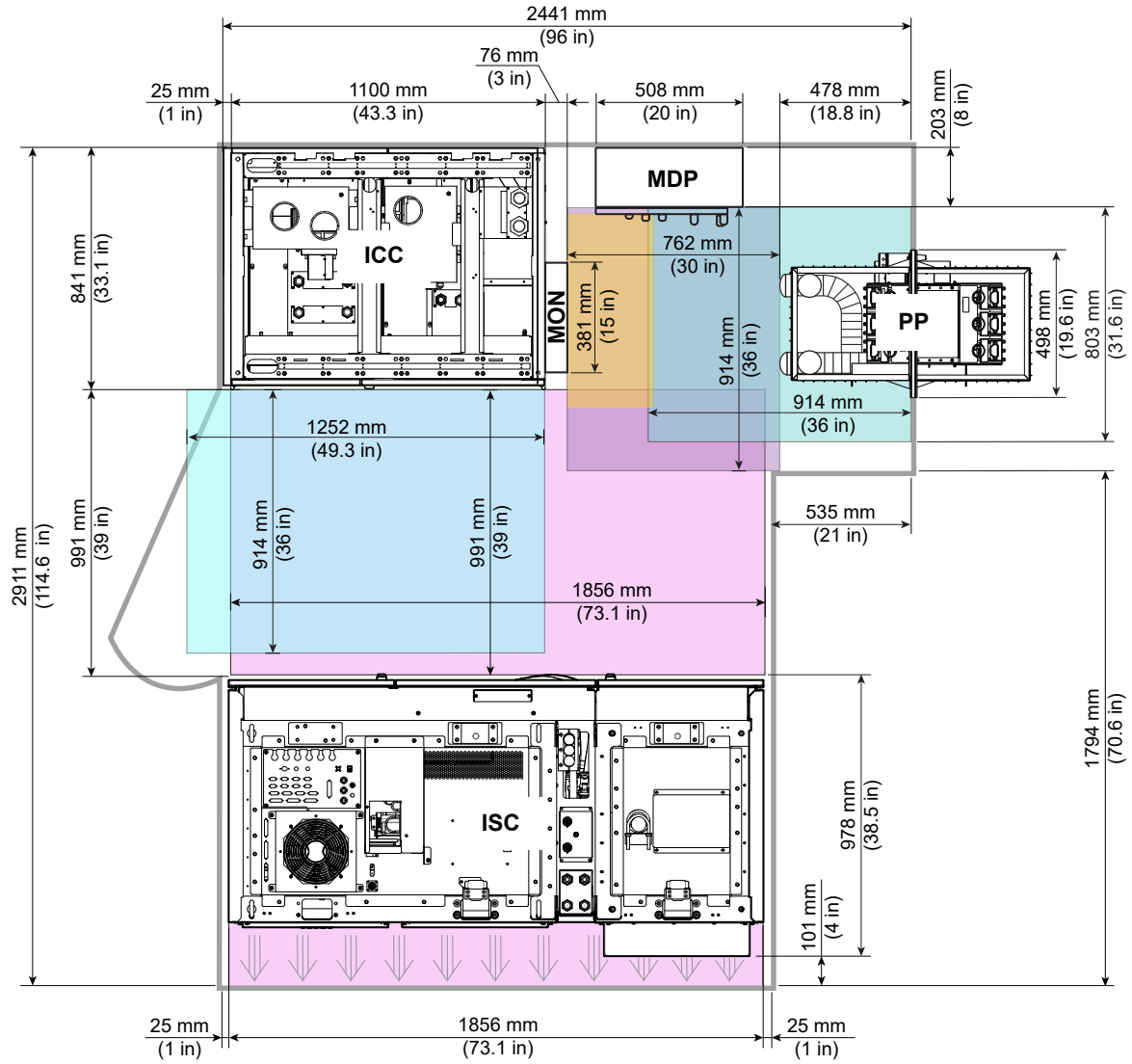

4.2 Main Disconnect Panel (MDP) Requirements and Specifications

4.2.1 Requirements

1. It is recommended to install the following items to support a power monitor:
 - 1.1. A T100 network connection with RJ45 connector near the MDP
 - 1.2. An electrical outlet
2. The cable must be Cat 5 or better.
3. The network connection must not be routed through the Ethernet switch in the Global Operator Cabinet (GOC).

4.2.2 Specifications

The Main Disconnect Panel (MDP) is provided with the MR System. Only exempt countries can supply their own MDP (see [2.11.3 Customer-supplied Main Disconnect Panel \(MDP\) Requirements \(exempt countries only*\)](#) on page 49).

1. 380-480V **M7100MD**, Weight: 58.6 kg (129 lb.)
2. Magnetic Field Limit: 5 mT (50 G)

Figure 4-2 GE HealthCare supplied Main Disconnect Panel (MDP) M7100MD

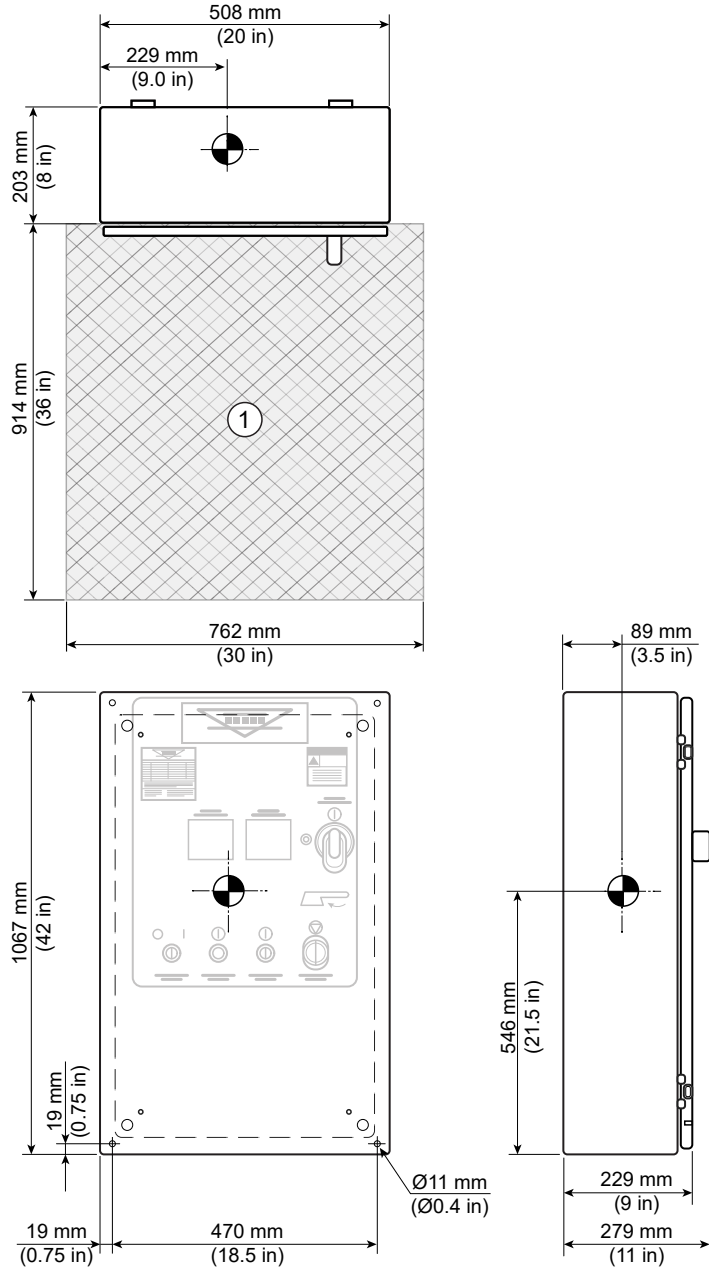

Item	Description
1	Service Clearance

4.3 Integrated System Cabinet (ISC) Specifications

1. Weight, ISC 1: 1034 kg (2279 lb.)
2. Weight, ISC 2: 1025 kg (2260 lb.)
3. Total Weight: 2059 kg (4539 lb.)
4. Maximum weight per caster: 272 kg (600 lb.)
5. Magnetic Field Limit: 5 mT (50 G)
6. The threaded seismic anchor mounting holes accommodate M8 bolts.
7. For seismic areas, the customer's contractor must provide and install brackets that secure the ISC cabinet to the wall and to the floor. See [Figure 4-3 Integrated System Cabinet \(ISC\) on page 85](#) for the location details for the mounting holes that the contractor will use to anchor the cabinet to the floor. Accommodations for floor mounting are available on the front and the sides of the cabinet. Accommodations for wall mounting are available on the top rear of the cabinet. Refer to [Figure 4-5 ISC wall brackets specifications \(short bracket\) on page 87](#) and [Figure 4-6 ISC wall brackets specifications \(long bracket\) on page 87](#).

Figure 4-3 Integrated System Cabinet (ISC)

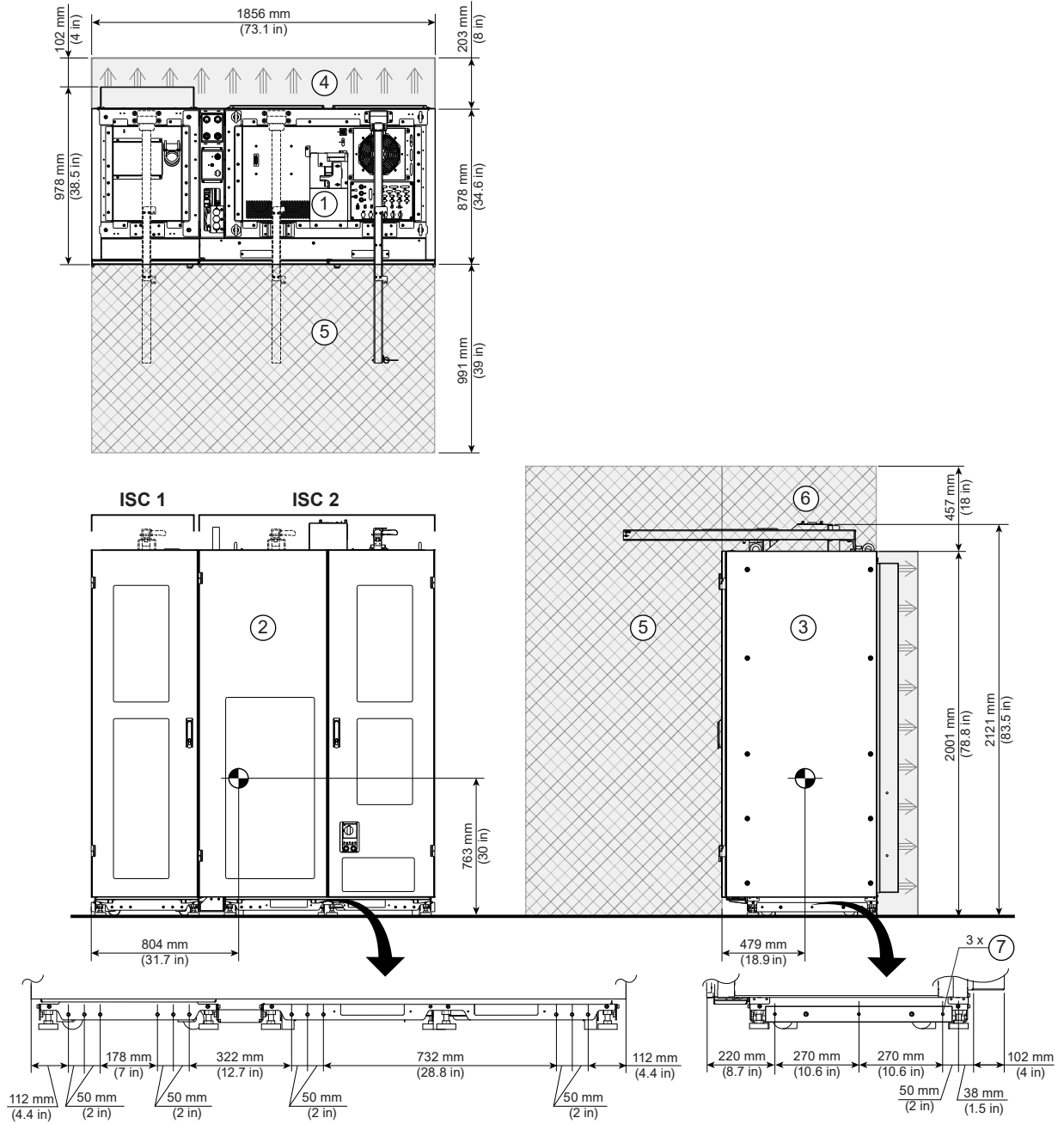

Item	Description	Item	Description
1	Top View	5	Service area
2	Front View	6	Minimum Space between Cabinet Top and Cable Tray
3	Side View	7	(18) M8 Seismic Anchor Mounting Holes
4	Air Flow between ISC and Wall	-	-



NOTE

The left side and the right side of the ISC floor anchor bracket locations are symmetrical.

Figure 4-4 ISC Anchor Bracket Location For Seismic Mounting

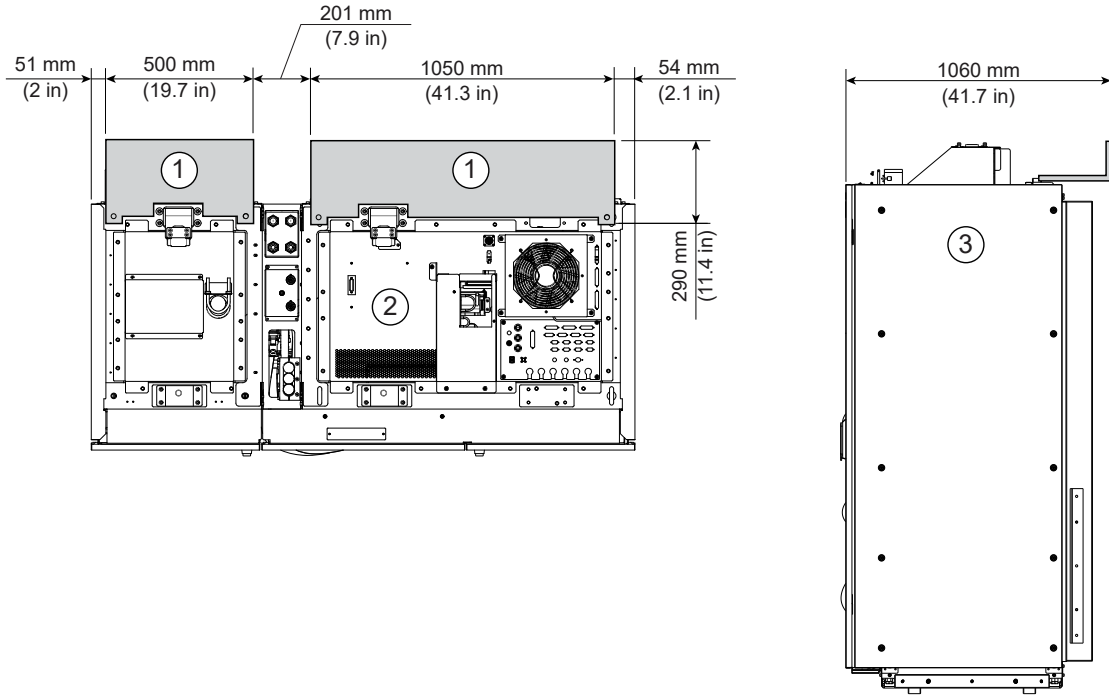

Item	Description	Item	Description
1	Bracket Locations	3	Side View
2	Top View	-	-

Figure 4-5 ISC wall brackets specifications (short bracket)

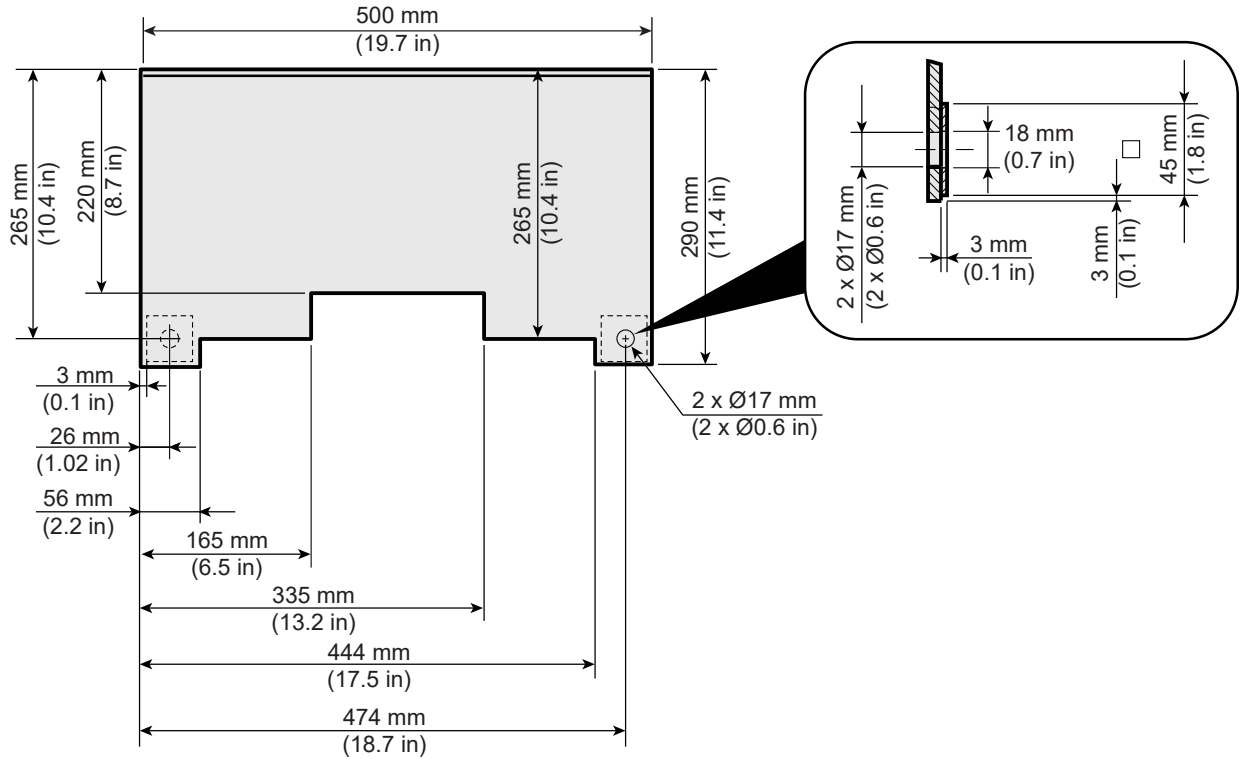
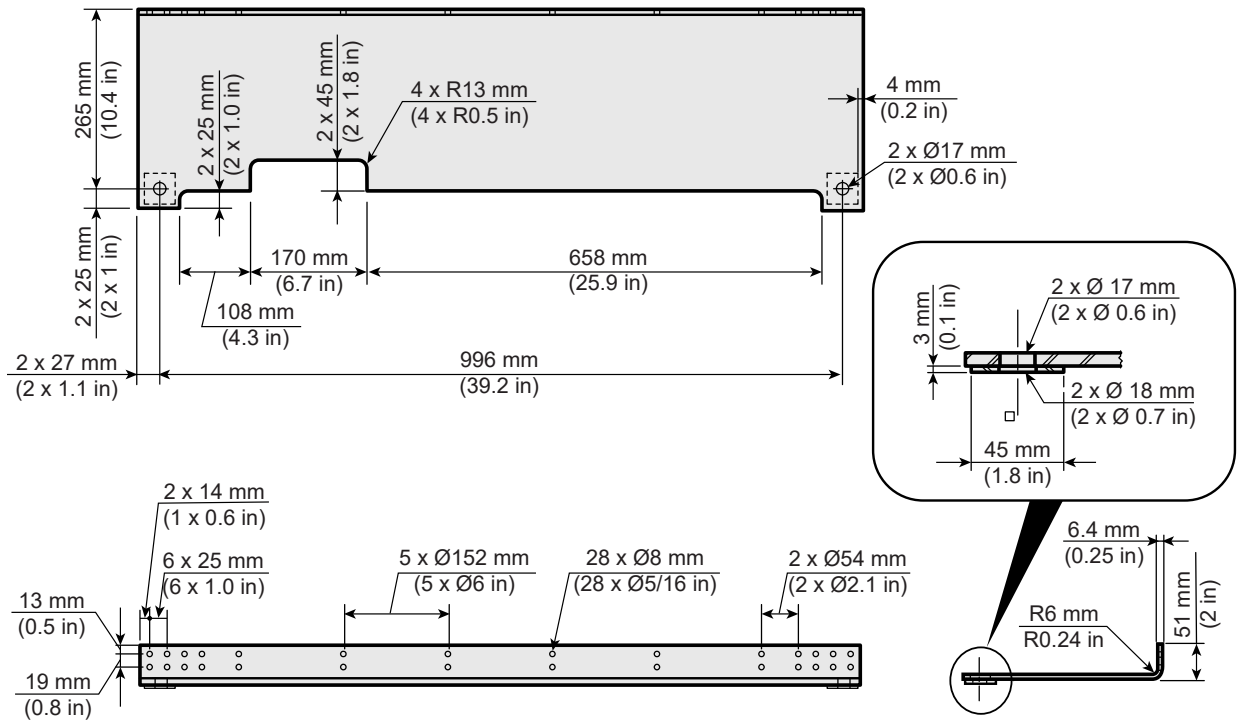

Figure 4-6 ISC wall brackets specifications (long bracket)



4.4 Integrated Cooling Cabinet (ICC) Specifications

1. ICC Weight with coolant, but without Cryocooler Compressor: 615 kg (1353 lb.)
2. F-50SH Cryocooler Compressor weight: Approx 125 kg (276 lb.)
3. Magnetic Field Limit: 5 mT (50 G) (Penetration Panel side)
4. The threaded seismic anchor mounting holes accommodate M12 bolts.
5. Seismic mounting of the ICC must be performed at the sides of the cabinet.

Figure 4-7 Integrated Cooling Cabinet (ICC)

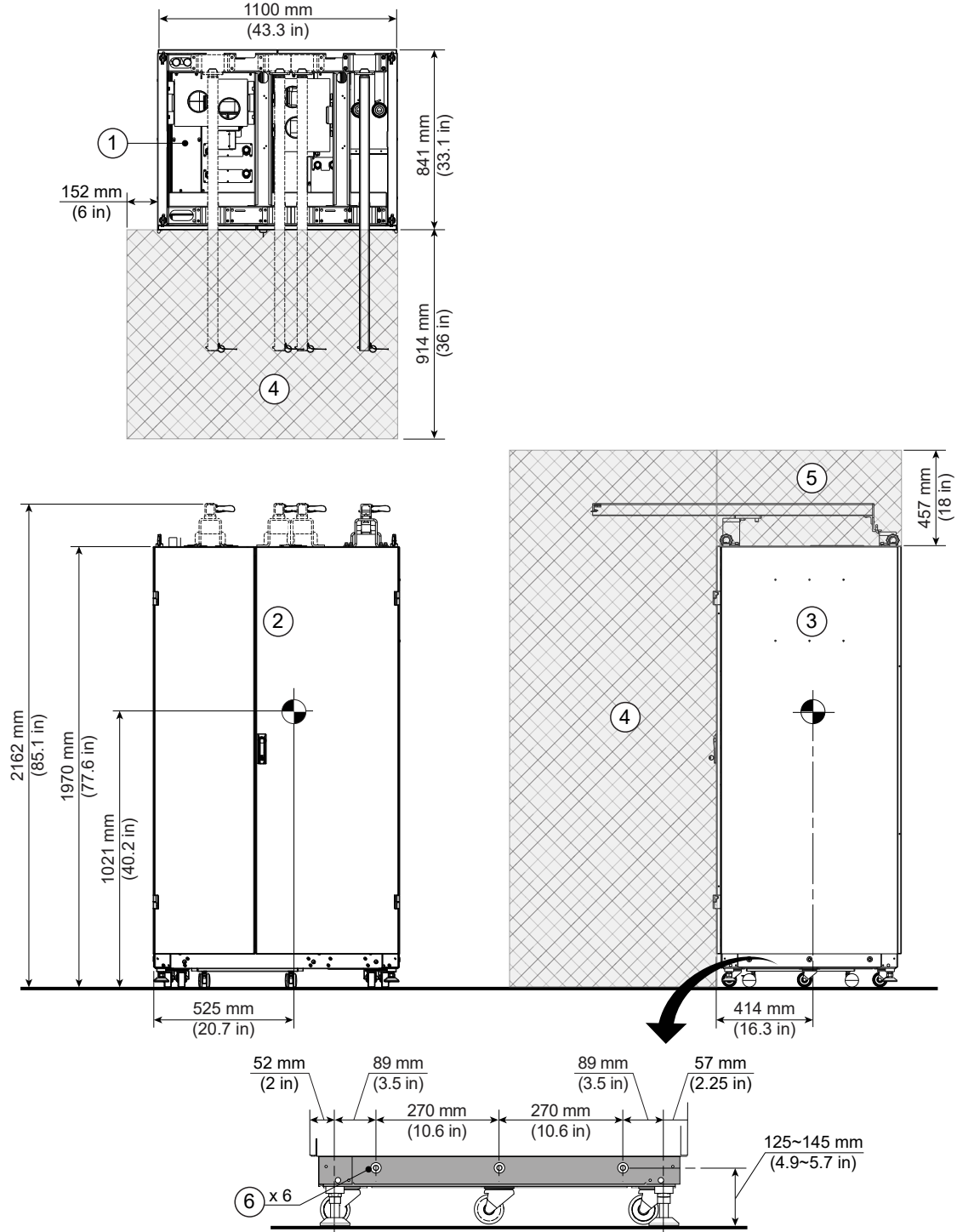

Item	Description	Item	Description
1	Top View	4	Service Area
2	Front View	5	Air Flow and Cables
3	Side View	6	(6) M12 Seismic Anchor Mounting Holes

**NOTE**

The left side and the right side of the ICC anchor bracket locations are symmetrical.

Figure 4-8 ICC Facility Water Supply and Return Connections Location

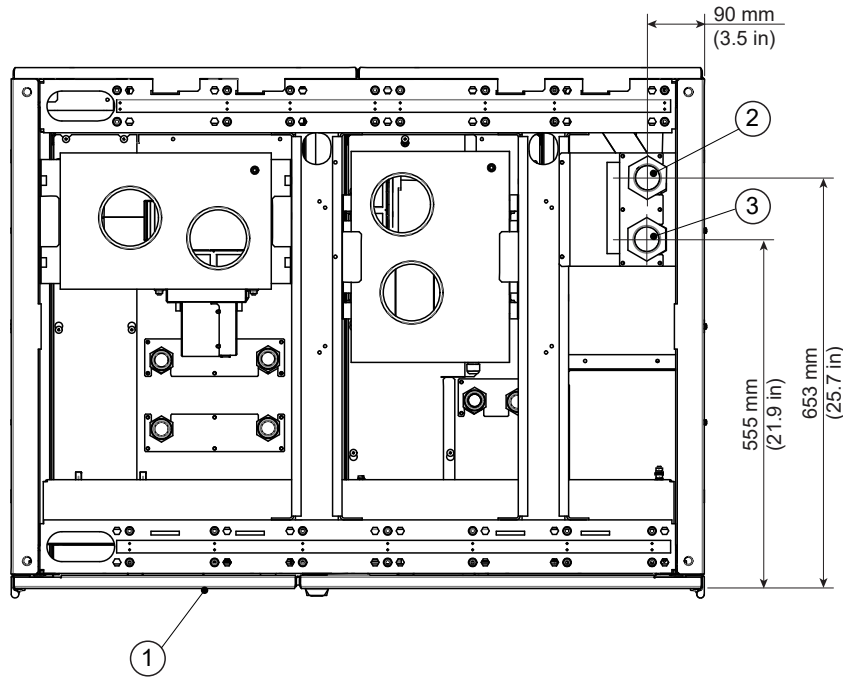

Item	Description	Item	Description
1	Cabinet Front	3	Facility Supply
2	Facility Return	-	-

4.5 Penetration Panel Specifications

The Penetration Panel provides interconnects from the Equipment Room through the Magnet Room RF Shield.

1. Weight: 30 kg (66.1 lb.)
2. Magnetic Field Limit: 20 mT (200 G)
3. Refer to [3.4 Penetration Panel Wall Opening Requirements on page 63](#) for mounting and location requirements.

Figure 4-9 Penetration Panel (PP)

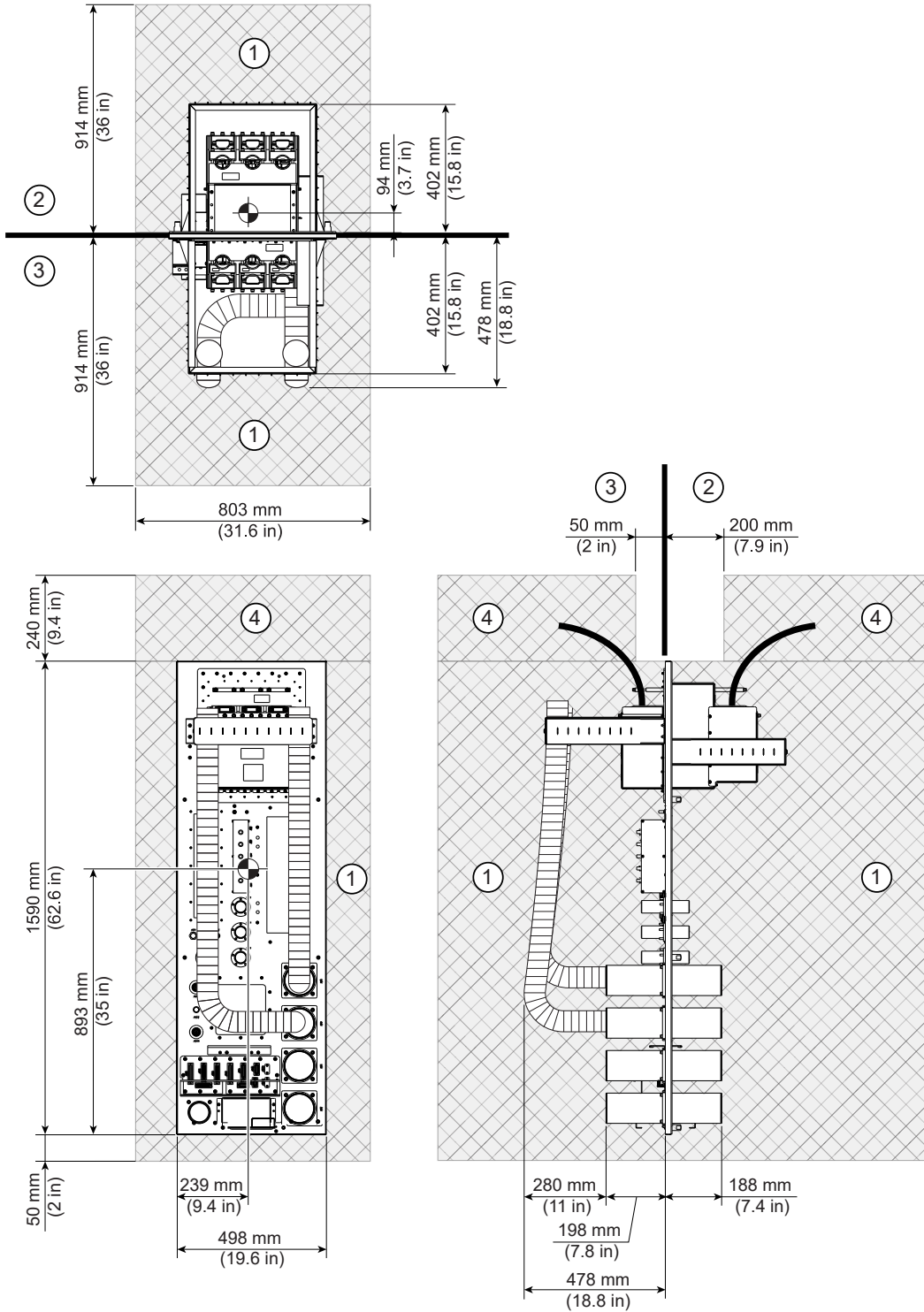

4.6 Magnet Monitor (MON) Requirements and Specifications

4.6.1 Requirements

1. Customer must supply T100 network connection with RJ45 connector to the Magnet Monitor (MON). Network connectivity must be active prior to magnet delivery.
2. The cable must be Cat 5 or better.
3. The network connection must not be routed through the Ethernet switch in the Global Operator Cabinet (GOC).

4.6.2 Specifications

1. Mounting location: On the wall or on either side of the ICC
2. Weight: 3.6 kg (8 lb.)
3. Magnetic Field Limit: 20 mT (200 gauss)
4. Power cord length: 1829 mm (72 in.)

Figure 4-10 Magnet Monitor (MON)

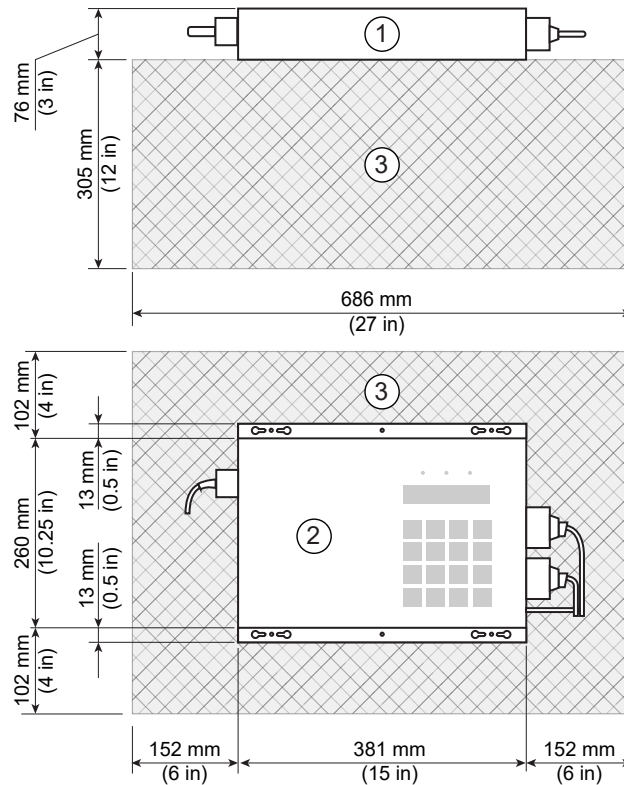

Item	Description	Item	Description
1	Top View	3	Service area
2	Front View	-	-

Figure 4-11 Magnet Monitor (MON) Mounting Patterns

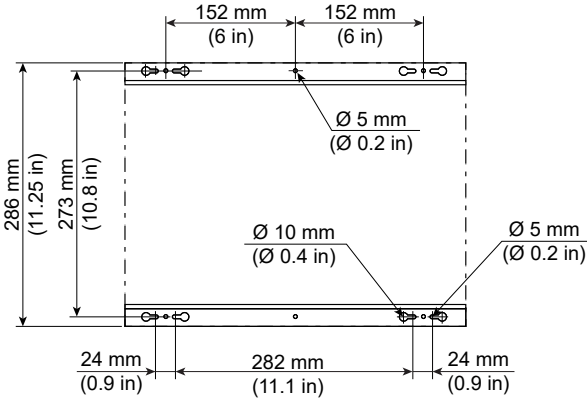

4.7 Magnetic Resonance Elastography (MRE) Specifications (Optional Equipment)

4.7.1 Requirements

1. The waveguide plate is mounted directly to the penetration panel. The 25 mm (1 in.) diameter tube will pass directly through the GE-provided waveguide on the penetration panel. Refer to [Figure 4-13 Waveguide on Penetration Panel for MRE on page 95](#).
2. MRE Resonant Acoustic Driver location is limited to the length of the 25 mm (1 in.) tube (see the available cable lengths in [7.1.4 Magnetic Resonance Elastography \(MRE\) Option on page 108](#)).

4.7.2 Specifications

1. Weight: 24.22 kg (53.4 lb.)
2. Magnetic Field Limit: 5 mT (50 G)
3. Power Cord Length:
 - 60 Hz: 6096 mm (240 in.)
 - 50 Hz: 7620 mm (300 in.)

Figure 4-12 Magnetic Resonance Elastography (MRE) Resonant Acoustic Driver

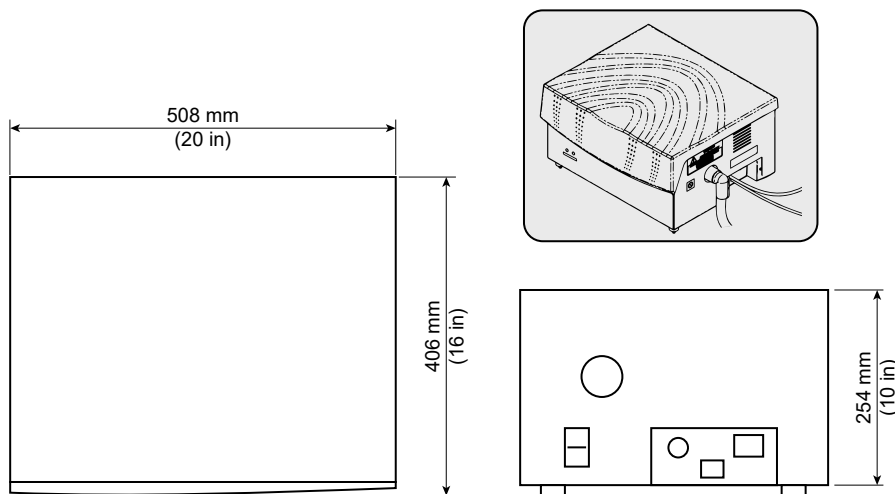
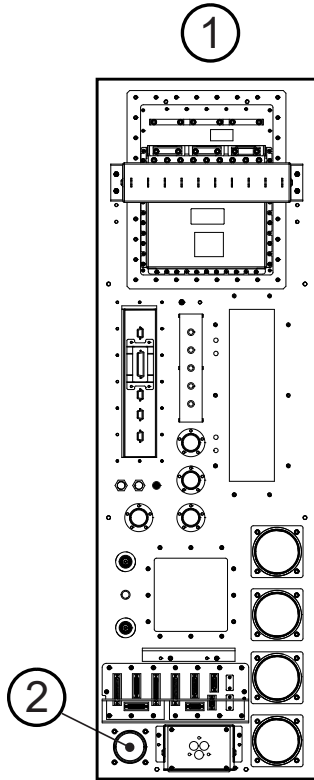

Figure 4-13 Waveguide on Penetration Panel for MRE



Item	Description
1	Equipment room
2	Waveguide for MRE

5 Control Room

5.1 Operator Workspace Equipment Specifications



(Applies to all sections within this chapter)

5.1.1 Operator Workspace Assembly

Figure 5-1 Operator Workspace Assembly

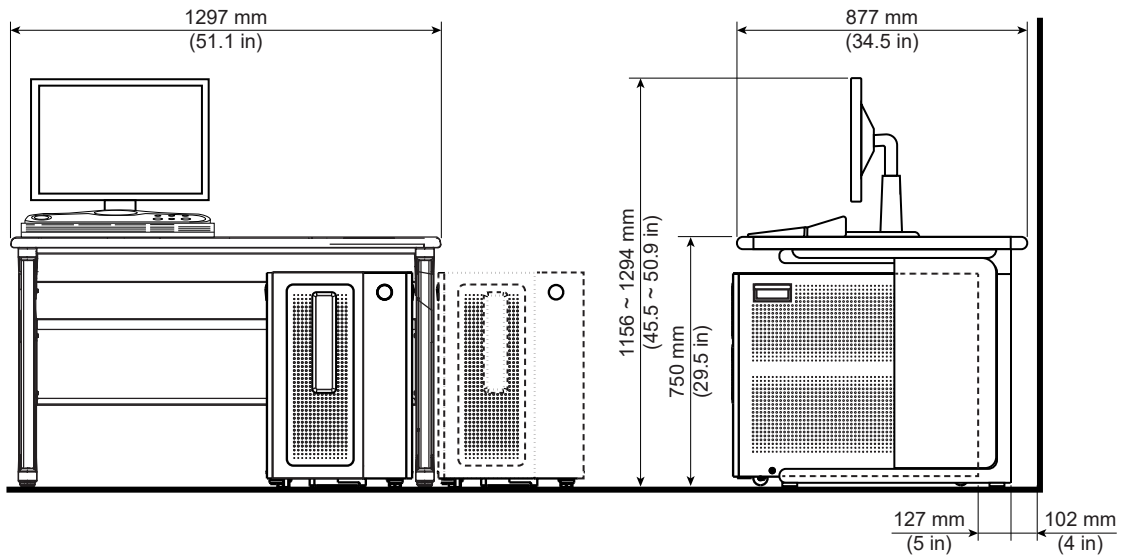

5.1.2 Operator Workspace (OW) (Optional Equipment)

Figure 5-2 Operator Workspace (OW) Table (Top and Front View)

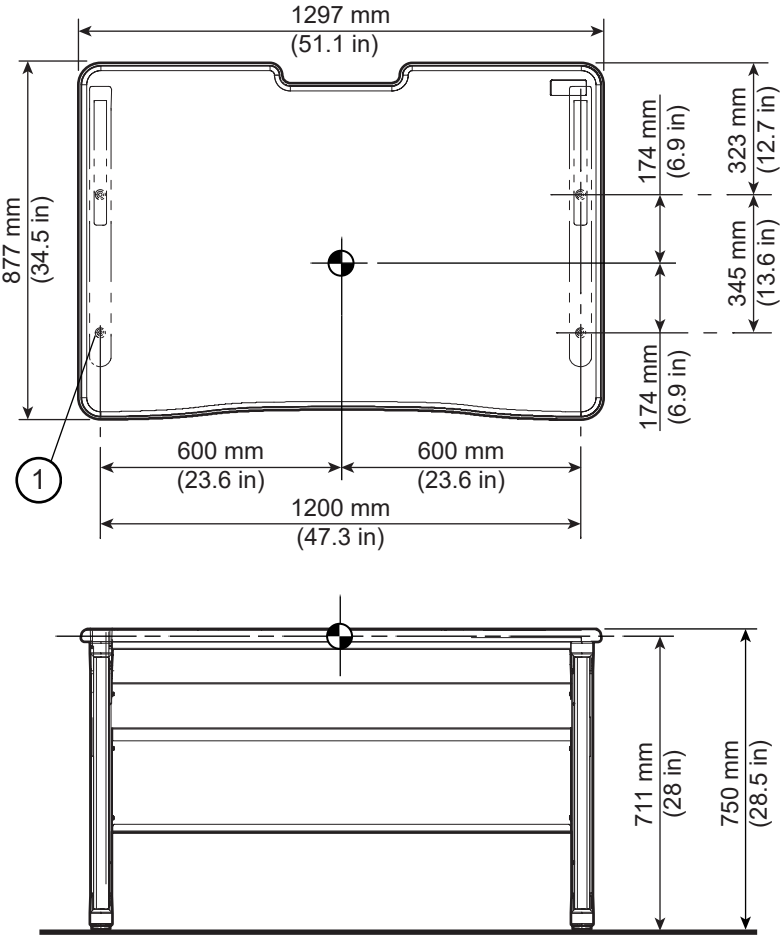

Item	Description
1	Four (4) 15.9 mm (5/8 in.) thru mounting holes for 9.5 mm (3/8 in.) seismic anchors

5.1.3 Global Operator Cabinet (GOC)

1. Weight:
For HP Z4G5: 54.7 kg (120.6 lb.)
2. Magnetic Field Limit: 5 mT (50 G)
3. Anchor size: M10 (3/8 in.)

Figure 5-3 Global Operator Cabinet (GOC)

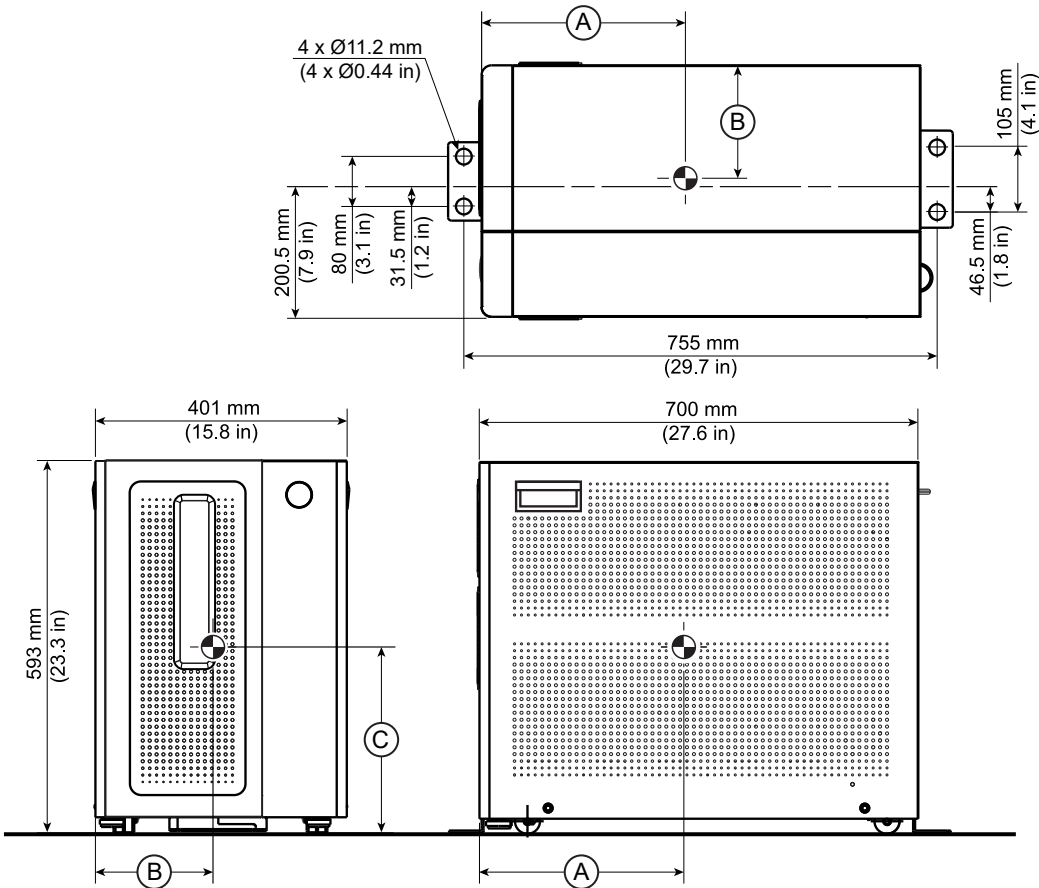

	A	B	C
HP Z4G5	375 mm (14.8 in.)	205 mm (8.1 in.)	330 mm (13 in.)

5.1.4 Host Display

Weight and dimensions for the Host Display are approximate and might vary depending on the display model.

- 1. Weight: 6.7kg (14.8 lb.)
- 2. Magnetic Field Limit: 5 mT (50 G)

Figure 5-4 Host Display

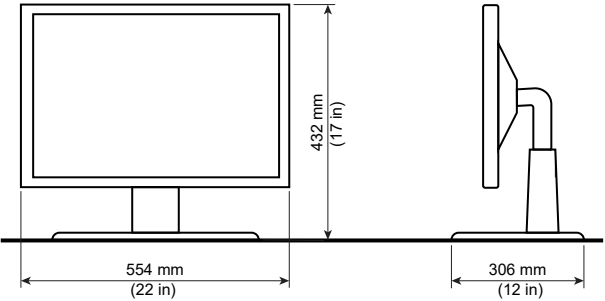

5.1.5 Host Keyboard

Figure 5-5 Host Keyboard

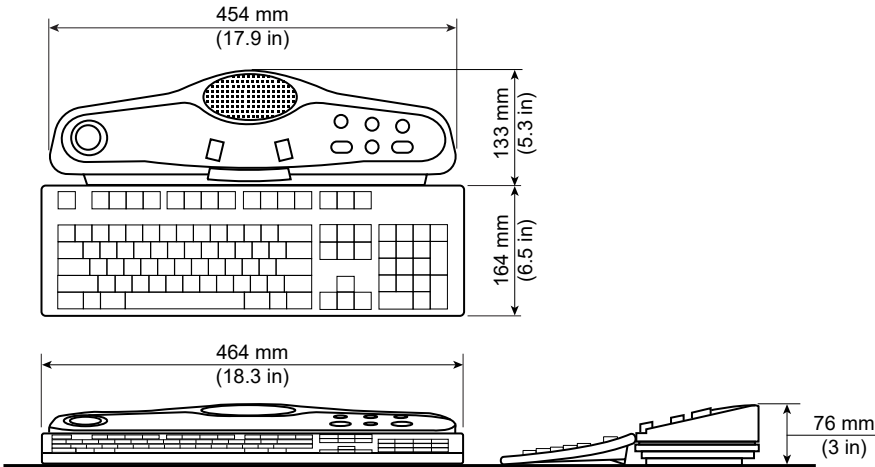

5.1.6 Pneumatic Patient Alert

The Pneumatic Patient Alert system allows the patient to contact the operator. The Control Box audible and visual alarm will be activated by the patient squeeze bulb which is located on the Magnet Enclosure and connected by pneumatic tubing through the Penetration Panel to the Control Box.

- 1. Weight 0.2 kg (0.5 lb.)
- 2. Magnetic Field Limit: 5 mT (50 G)
- 3. The Control Box must be placed or mounted within reach of the operator and within 1.5 m (5 ft.) of an electrical outlet.

Figure 5-6 Pneumatic Patient Alert (PA) with Mounting Pattern

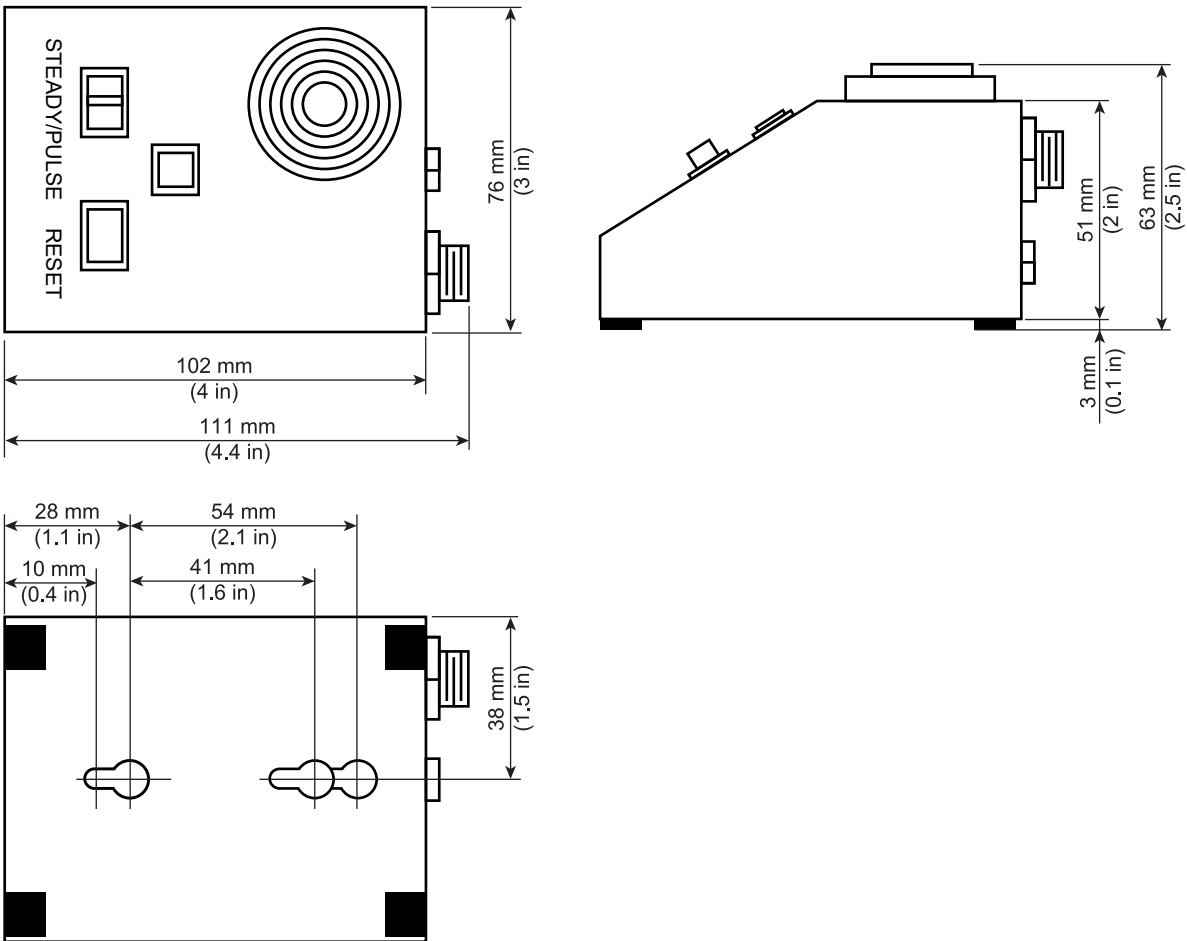

5.2 Oxygen Monitor (OXY) Specifications (Optional Equipment)

The optional Oxygen Monitor system consists of the Oxygen Monitor, the Remote Oxygen Sensor Module, and interconnects through the Penetration Panel. The Oxygen Monitor alarm is located near the Operator Workspace and is activated by the Remote Oxygen Sensor Module in the Magnet Room.

1. Oxygen Monitor Weight: 3.6 kg (8 lb.)
2. Oxygen Sensor Module Weight: 0.9 kg (2 lb.)
3. Magnetic Field Limit: 5 mT (50 G)

Figure 5-7 Oxygen Monitor and Remote Sensor

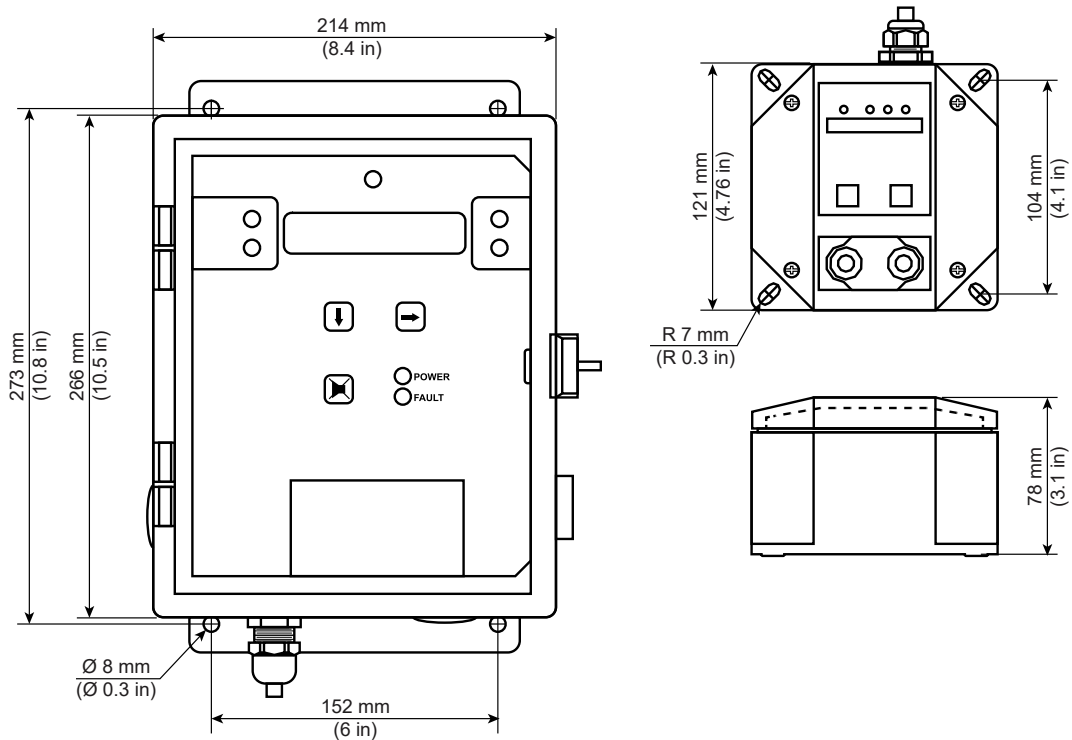

5.3 Physiological Acquisition Transceiver (PAT) Charging Station Specification (Optional Equipment)

The charging station supports the docking and charging of the Physiological Acquisition Transceiver (PAT). It is intended for installing outside the MR scanner magnet room, typically in the Control room. The charging station provides hooks for draping the ECG cable and respiratory sensor cable to facilitate cable management.

1. The charging cradle can be placed on the desktop or mounted on the wall.
2. A clean, level surface tabletop is required for desktop placement method.
3. Charging station wall mounted configuration maximum weight: 4.2kg (9.3 lbs)
4. Magnetic Field Limit: 5 mT (50 G)
5. The charging cradle must be placed or mounted within 3000 mm (118 in.) of an electrical outlet.

Figure 5-8 Charging Cradle Desktop and Wall Mounting Configuration

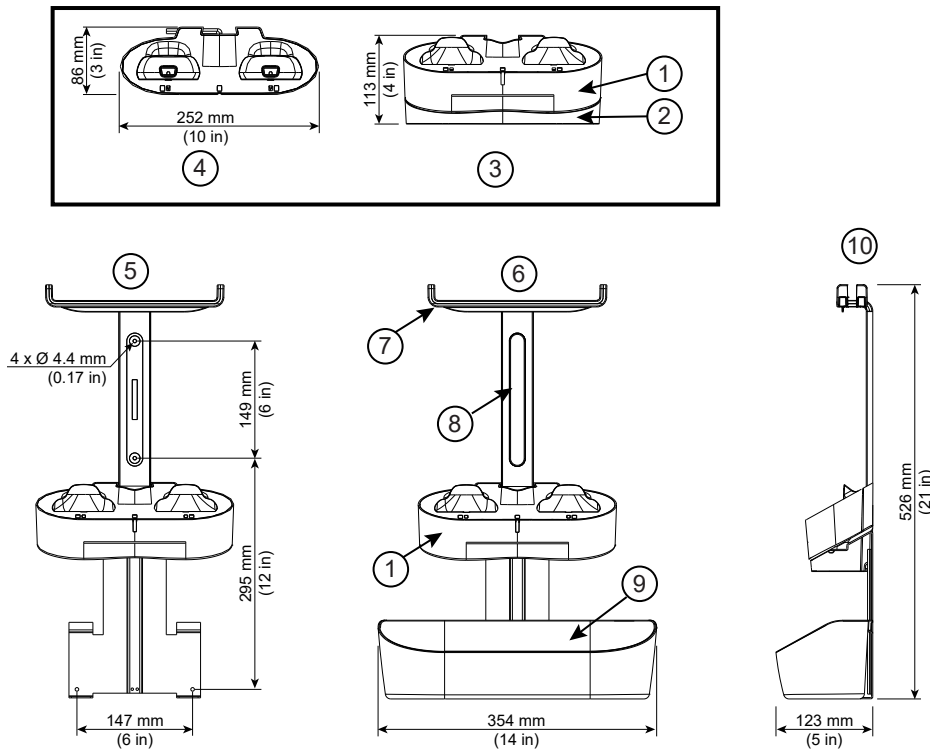

Item	Description	Item	Description
1	Charging cradle	6	Front View - wall mounting configuration with storage basket
2	Desktop base adapter	7	Storage hooks
3	Front View - desktop configuration	8	Wall mount support
4	Top View - desktop configuration	9	Storage basket
5	Front View - wall mounting configuration	10	Side View - wall mounting configuration with storage basket

6 Digital Service and Connectivity Requirements

6.1 InSite RSvP (Remote Service Platform) Requirements



(Applies to all sections within this chapter)

6.1.1 InSite RSvP Connectivity Requirements

Following are the requirements for InSite RSvP connectivity:

1. The customer shall provide a physical connection or a route to an existing enterprise LAN.
2. The cable must be Cat 5 or better.
3. The customer shall provide outbound internet access for the device using HTTPS protocol over port 443.
4. The customer's network administrators shall provide DNS IP Address or Proxy IP address and authentication information (if applicable for the proxy server).
5. The customer's network administrators shall whitelist the following URLs:
 - Enterprise production:
 - <https://insite.gehealthcare.com:443>
 - <https://as1-insite.gehealthcare.com>
 - <https://as2-insite.gehealthcare.com>
 - Flexera URL: <https://gehealthcare-ns.flexnetoperations.com>
 - Flexera Software Download URL: <https://download.flexnetoperations.com>
 - For EU regions, whitelist the following:
 - <https://as1-insite-eu.gehealthcare.com>
 - <https://insite-eu.gehealthcare.com>

7 MR System Interconnects

7.1 MR System Interconnects Specifications



(Applies to all subsections within this section)

7.1.1 Component Designator Definitions

GE HealthCare uses Component Designators to identify system components. All subsystem cabinets and other components are referred to by their component designators in the Interconnect Data diagrams and tables.

Table 7-1 MR System Component Designators

Component Designator	Description
CRY	Cryocooler Compressor Cabinet
DS, DS1	Door Switch
E01, E02, and so on	Emergency-Off (E-Off) Buttons
ICC	Integrated Cooling Cabinet
ISC	Integrated System Cabinet
MAG	Magnet and Enclosure (all magnet enclosure components in Magnet Room)
MDP	Main Disconnect Panel
MON	Magnet Monitor
MRU	Magnet Rundown Unit
OW	Operator Workstation
PA1	Pneumatic Patient Alert Control Box
PDU	Power Distribution Unit (PDU) is a module in the ISC cabinet
PT	Patient Transport Table

Table 7-2 MR System Options Component Designators

Component Designator	Description
MRE	Magnetic Resonance Elastography
OXY	Oxygen Monitor
PAT CS	Physiological Acquisition Transceiver Charging Station

7.1.2 Available Cable Lengths

Two configurations of cable lengths are available for order, and multiple selections for gradient cables. Gradient cables are no longer field terminated, and it is critical to select an appropriate length to

avoid too much excess. To determine required cable lengths, find the total distance of the cable path between the specified equipment by measuring the following:

- distance from the top of the specified equipment up to the cable tray
- horizontal distance across the cable tray
- distance from the cable tray to the top of the other specified equipment

Compare the total distance to the lengths specified in [Table 7-3 Available Cable Lengths on page 105](#). If your total distance is more than the "Short" distance, but less than the "Long" distance, the Site Option is "Long." If your distance is longer than the Usable cable length given in below list, you must reconfigure the layout of the room.

Table 7-3 Available Cable Lengths

Length Identifier (shown in the figure below)	Point A	Point B	Site Option: Short	Site Option: Long
			mm (in.)	
Equipment Room				
Not Shown	MON	Top of ICC (CRY)	8500 (334.6)	
L1 ²	MDP	ICC Top (CRY Power)	7500 (295.3)	
L2	MON	ICC, top panel	15000 (590.6)	
L3	MON	ISC, top panel	16400 (645.7)	
Not Shown	MON	Facility outlet for MON power	3000 (118.1)	
Not Shown	MON	Hospital ethernet switch	30000 (1181.1)	
L4	ISC, top panel	ICC, top panel	7500 (295.3)	
L5	ISC, top panel	OW, rear panel	25000 (984.3)	
L6	ISC, top panel	Magnet Room Door Switch	24000 (944.8)	
L7 (This length is for all cables and hoses except for gradient cables and RF cables. For gradient cable and RF cable avail- able lengths, refer to Table 7-4 Availa- ble Cable Lengths for Gradient Cable and RF Cable (Equipment Room, Top of ISC to Pen Panel Top Edge on page 106))	ISC, top panel	PP top edge	7400 (291.3)	14200 (559)
Not Shown	PP top edge	E-off switch, Control room or Equipment room	9000(354.3)	16000(629.9)
L8	ICC, top panel	PP top edge	9000(354.3)	11500(452.7)
L9	ISC, top panel	MAG, gradient cable clamp block	25000 (984.2)	

Table 7-3 Available Cable Lengths (Table continued)

Length Identifier (shown in the figure below)	Point A	Point B	Site Option: Short	Site Option: Long
			mm (in.)	
L10	ICC, top panel	MAG (Gradient cooling manifold)	28000 (1102.3)	
L14	MON	PP top edge	15000 (590.5)	
L15 ¹	ICC, Top panel (CRY)	MAG (cold head)	15000 (590.5)	
Magnet Room				
L11 (This length is for all cables and hoses except for gradient cables and RF cables. For gradient cable and RF cable available lengths, refer to Table 7-5 Available Cable Lengths for Gradient Cable and RF Cable (Magnet Room, Magnet Gradient Cable Strain Relief Plate to Pen Panel Top Edge) on page 107)	MAG, gradient cable clamp block	PP top edge	10000 (393.7)	
Not Shown	PP top edge	E-off switch, Magnet Room	25000 (984.2)	
L12	OW, rear panel	MAG, gradient cable clamp block	42000 (1653.5)	
L13	MRU	MAG, gradient cable clamp block	24700 (972.4)	
 NOTE ¹ 6000 mm (236.2 in.) extender flex hoses (M7088EL) can be used if needed. ² A customer-supplied substitute can be used if the supplied run is shorter than required.				

Table 7-4 Available Cable Lengths for Gradient Cable and RF Cable (Equipment Room, Top of ISC to Pen Panel Top Edge)

Pen Panel Top Edge	Available lengths mm (in.)
L7 Gradient cable	4600 (181)
	6600 (260)
	8600 (339)
	10600 (417)
	12600 (496)
	14600 (575)
L7 RF Cables	7000 (276)
	13000 (512)

Table 7-5 Available Cable Lengths for Gradient Cable and RF Cable (Magnet Room, Magnet Gradient Cable Strain Relief Plate to Pen Panel Top Edge)

Pen Panel Top Edge	Available lengths mm (in.)
L11 Gradient cable	4600 (181)
	6600 (260)
	8600 (339)
	10600 (417)
L11 RF Cables	9000 (354)
	13000 (512)



NOTE

Figure 7-1 Available Cable/Hose Lengths on page 107 does not show cable trays. This figure is for reference only, to show available cable lengths and not to be used to design cable routing.

Figure 7-1 Available Cable/Hose Lengths

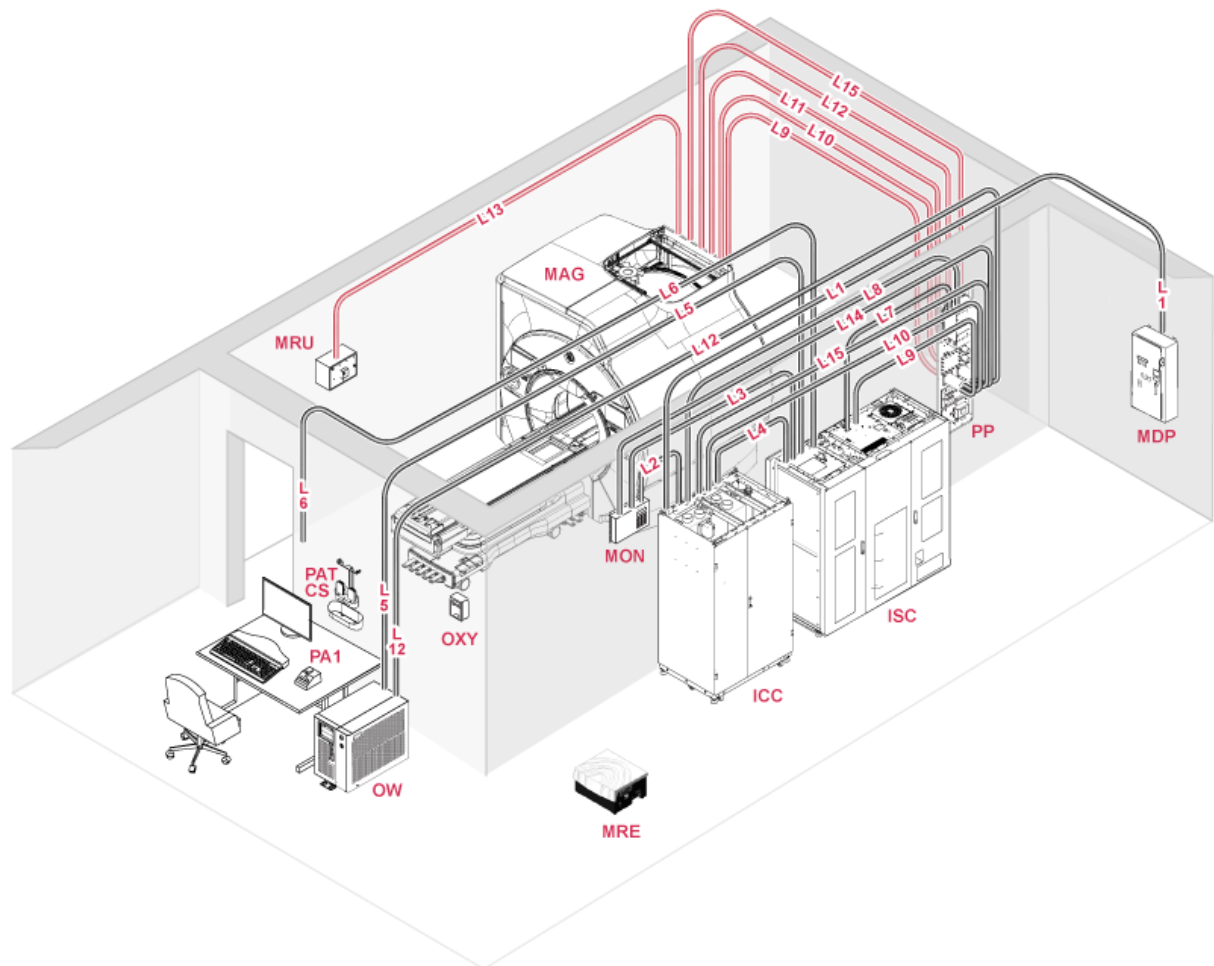

NOTE

MRE, PAT Charging Station and OXY shown above are optional components of the system.

7.1.3 BrainWave Option

Table 7-6 BrainWave Option Usable Cable Lengths

Cable	From	To	Cable Length mm (in.)
9-pin D-sub to JF-50	PP, top edge	Top of GOC	33799 (1331)
9-pin D-sub to BNC	ISC, top edge	Top of GOC	26532 (1045)
9-pin D-sub to Coax	PP, top edge	MAG, gradient cable clamp block	13479 (531)

7.1.4 Magnetic Resonance Elastography (MRE) Option

Table 7-7 MRE Option Available Cable Lengths

Cable	Point A	Point B	mm (in.)
25 mm (1 in.) Tubing	Resoundant Active Driver	Magnet (Isocenter)	Nominal 7315 (288) Maximum 10058 (396)
BNC	Resoundant Active Driver	ISC	15240 (600)
Ethernet	Resoundant Active Driver	Ethernet Hub in ISC	15240 (600)
Power	Resoundant Active Driver	Customer-Supplied Outlet	60 Hz: 6096 (240) 50 Hz: 7620 (300)

7.1.5 Storage Requirements for Excess Gradient Cable

1. Excess gradient cable must be stored on a wall hook inside the penetration panel closet in the Magnet Room and on a hook anchored into the Equipment Room wall. GE HealthCare supplies one hook per cable.
2. Supports and anchorage must be able to hold up to 22.7 kg (50 lb.) of weight per cable.
3. Excess gradient cable can be stored in a single loop (no more than one loop per cable) with a minimum bend radius of 330 mm (13 in.).
4. Supports shall be anchored no more than 2591 mm (102 in.) above the floor.

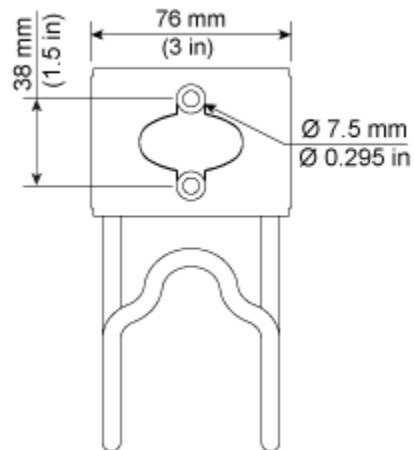
Figure 7-2 Gradient Cable Mounting Hook Mounting Detail**NOTE**

The examples below are representative of possible cable layout or configuration. Layout may vary depending on size, shape and configuration of the penetration panel closet. Configure cables to best suit the install configuration without violating the requirements above.

Figure 7-3 Gradient Cable Storage Vertical Layout (Example)

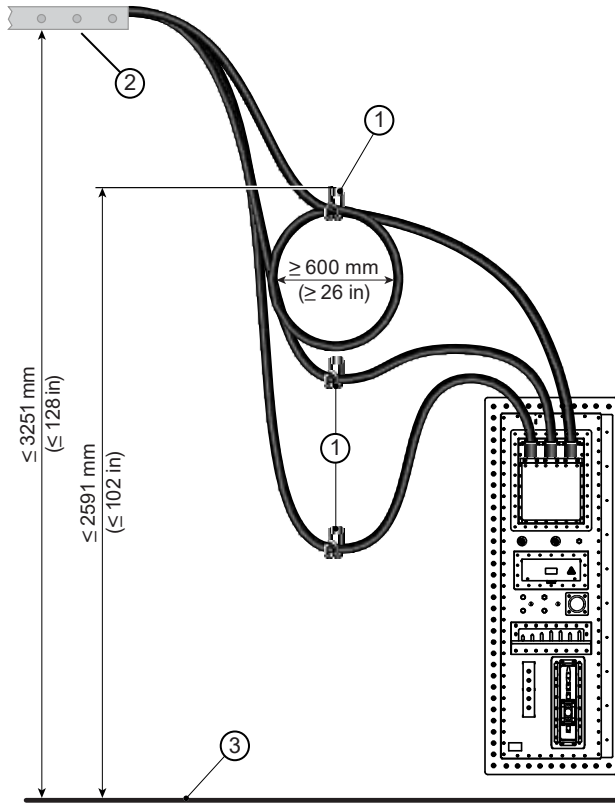

Item	Description	Item	Description
1	GE HealthCare-supplied gradient cable mounting hooks	3	Finished floor
2	Cable tray		

Figure 7-4 Gradient Cable Storage Horizontal Layout (Example)

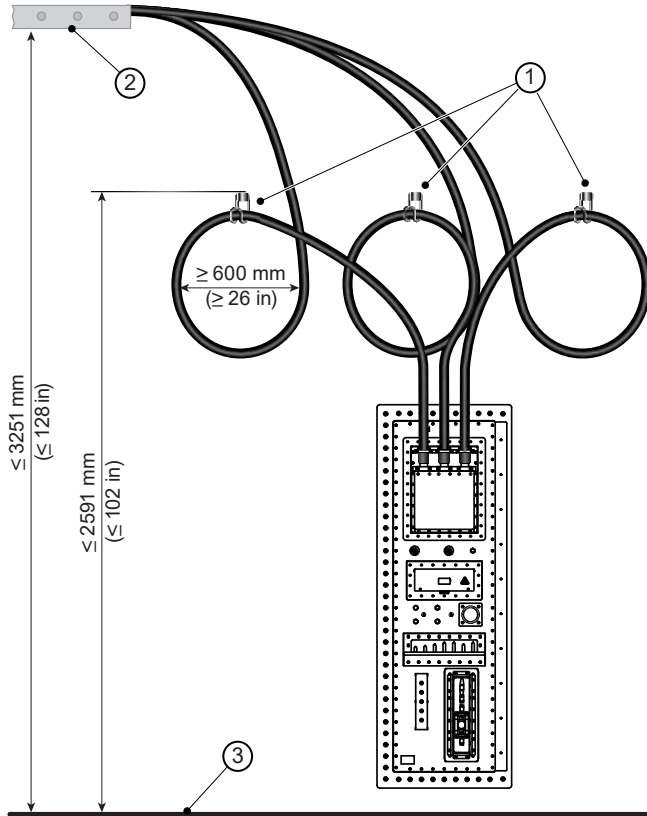

Item	Description	Item	Description
1	GE HealthCare-supplied gradient cable mounting hooks	3	Finished floor
2	Cable tray		

7.2 MR System Interconnects Routing Requirements



(Applies to all subsections within this section)

7.2.1 General Requirements

1. The customer is responsible for the purchase and installation of all cable support mechanisms.
2. Any type of nonferrous cable support can be used, such as a commercially available ladder or wire rack style cable trays, if the cable trays meet all MR System requirements.
3. The distance between cable supports must be less than 305 mm (12 in.). For example, the distance between rungs on a ladder tray, or the distance from the end of a cable tray to a final nonferrous cable support must be 305 mm (12 in.) or less.
4. The cable supports must have the minimum cable bend radius per MR System Cable Specifications. For example, the vertical and horizontal bends of the gradient cables must have a bend radius of 330 mm (13 in.).
5. Cable supports can be stacked or side-to-side.
6. If trays are stacked, the air, water, and cryogen lines must be run in the lower support (see [Figure 7-6 Cable Groupings on page 114](#)).
7. Each cable tray must support a weight of at least 74.8 kg/m (50 lb./ft.).



NOTE

If stacked, each cable tray must support the weight of both cable trays: that is 149.6 kg/m (100 lb./ft.).

8. Cables must be accessible on at least one side of the cable support and require a minimum of 254 mm (10 in.) from the top of the tray. (For example, see [Figure 7-7 Cable Tray Requirements Example \(Side-By-Side\) on page 115](#) or [Figure 7-8 Cable Tray Requirements Example \(Stacked\) on page 116](#).) If this is not possible due to obstructions, see the exceptions below.
9. All individual cable supports (for example, rungs) require lateral support to maintain the positions specified in the illustrations both during installation and after installation of the interconnects (for example, cables).

Exceptions for Obstructions:

1. The top of the cable tray must not touch an obstruction. A minimum of 254 mm (10 in.) of clearance is required on either side of the obstruction. See [Figure 7-5 Obstruction Example on page 113](#).
2. A minimum of 178 mm (7 in.) of clearance is required from the top of the tray rung to the lowest point of any obstruction.

**NOTE**

The illustration below shows how to route cable trays around HVAC ducts, light fixtures, medical gases, structural beams, and other obstructions. If local code permits, a tray with a bend can route the cables underneath an obstruction. At the rear of the magnet, the cable tray must be installed at the minimum height. The part of the cable tray that is under the obstruction can be installed at a lower height. The tray bend must provide the minimum cable bend radius.

Figure 7-5 Obstruction Example

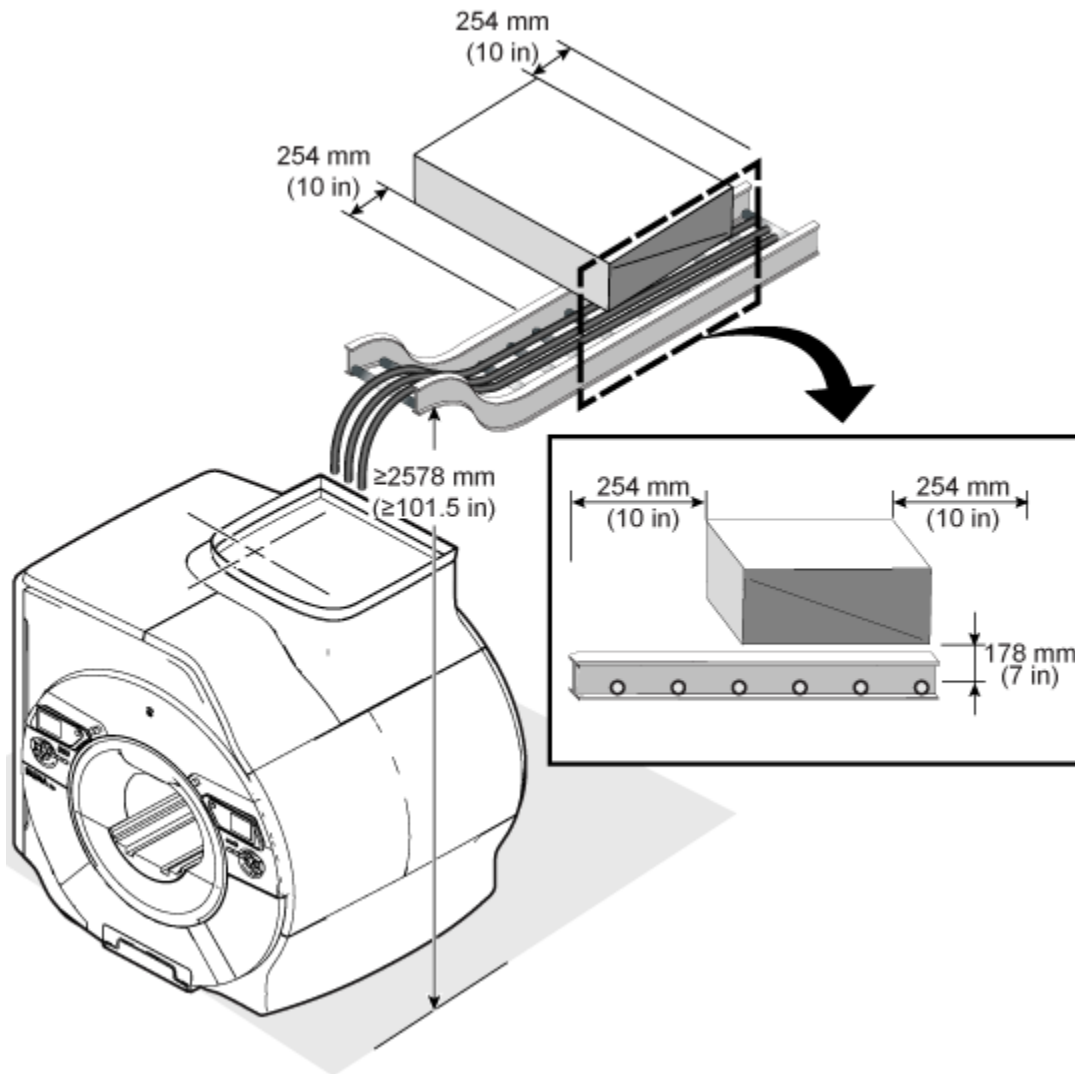

7.2.2 Magnet Room Requirements

1. Two cable trays must be used, each at least 450 mm or 18 in. wide.
2. Installation and routing of cable trays must be coordinated with the RF shield vendor.
3. Side-to-side trays in the Magnet Room must not touch to prevent RF broadband noise caused by metal-to-metal sidewall contact.
4. Ceiling grid work, medical gas lines, lighting fixtures, and so on, must not touch MR System cabling or cable supports.

5. Excess cable length in the Magnet Room must be stored in either:
 - 5.1. Penetration Panel closet. If utilizing the Penetration Panel Closet for cable storage, the supports and anchors must be able to hold up to 22.7 kg (50 lb.).
 - 5.2. Magnet Room cable trays (excess cable must be at least 915 mm (36 in.) from the magnet end of the tray).

7.2.3 Recommended Cable Groupings

We recommend the grouping order shown below. The cable groups must not touch. Local code may require dividers, channeling, bundling, and so on.

- Group a — Gradient and RF common ground cables

In the Magnet Room, the gradient cable group must be laid in a single layer. The center of cable group “a” is 89 mm (3.5 in.) from the inside edge of the tray, in line with the magnet center. See [Figure 7-6 Cable Groupings on page 114](#).

- Group b — Coax, RF, and AC power cables with jacket rating of 600V and above
- Group c — Data and fiber optic and 300V coax or RF clock cables
- Group d — 300V signal, 300V power, and 300V power and signal cables
- Group e — Air, water, and cryogen lines

Figure 7-6 Cable Groupings

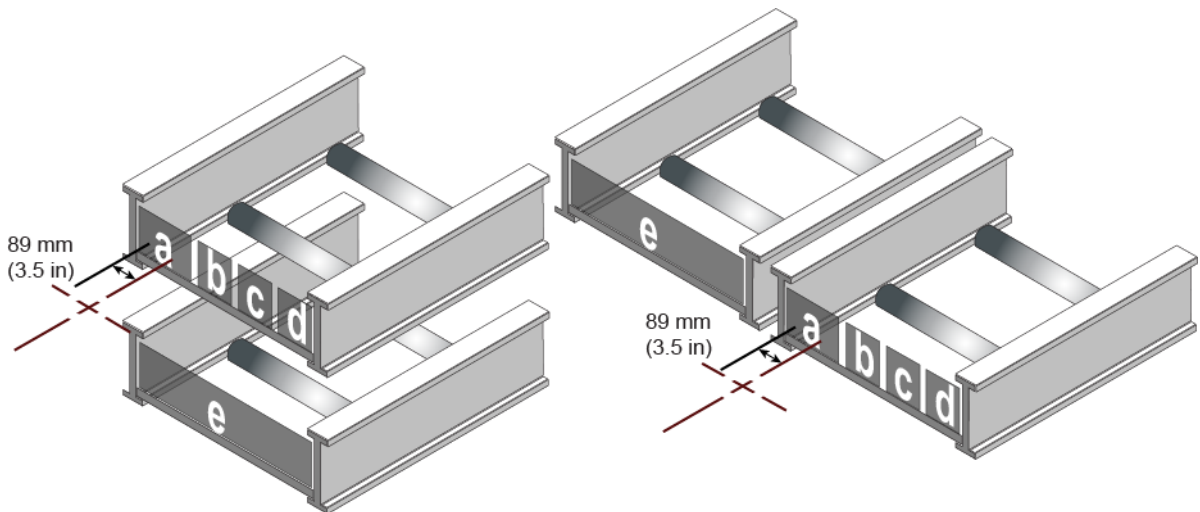

7.2.4 Cable Tray Requirements and Examples

1. The gradient cable support must end at the back of the magnet 1245 ± 12 mm (49 ± 0.5 in.) from the geometric isocenter, and must be parallel to the rear face of the magnet. See [Figure 7-7 Cable Tray Requirements Example \(Side-By-Side\) on page 115](#), [Figure 7-8 Cable Tray Requirements Example \(Stacked\) on page 116](#), and [Figure 7-9 Cable Tray Requirements Example \(90° Magnet Interface\) on page 117](#).
2. Supports for all other cables and hoses must end at the back of the magnet 864 ± 12 mm (34 ± 0.5 in.) from the geometric isocenter, and must be parallel to the rear face of the magnet.
3. Cable supports must have a minimum height of 2578 mm (101.5 in.) at the back of the magnet measured from the floor. See [Figure 7-7 Cable Tray Requirements Example \(Side-By-Side\) on page 115](#).

**NOTE**

Supports may be lower at other points along the route to clear obstructions as long as all other requirements are met.

- The top of the cable tray must be less than 3251 mm (128 in.) above the finished floor. See [Figure 7-7 Cable Tray Requirements Example \(Side-By-Side\)](#) on page 115.

Figure 7-7 Cable Tray Requirements Example (Side-By-Side)

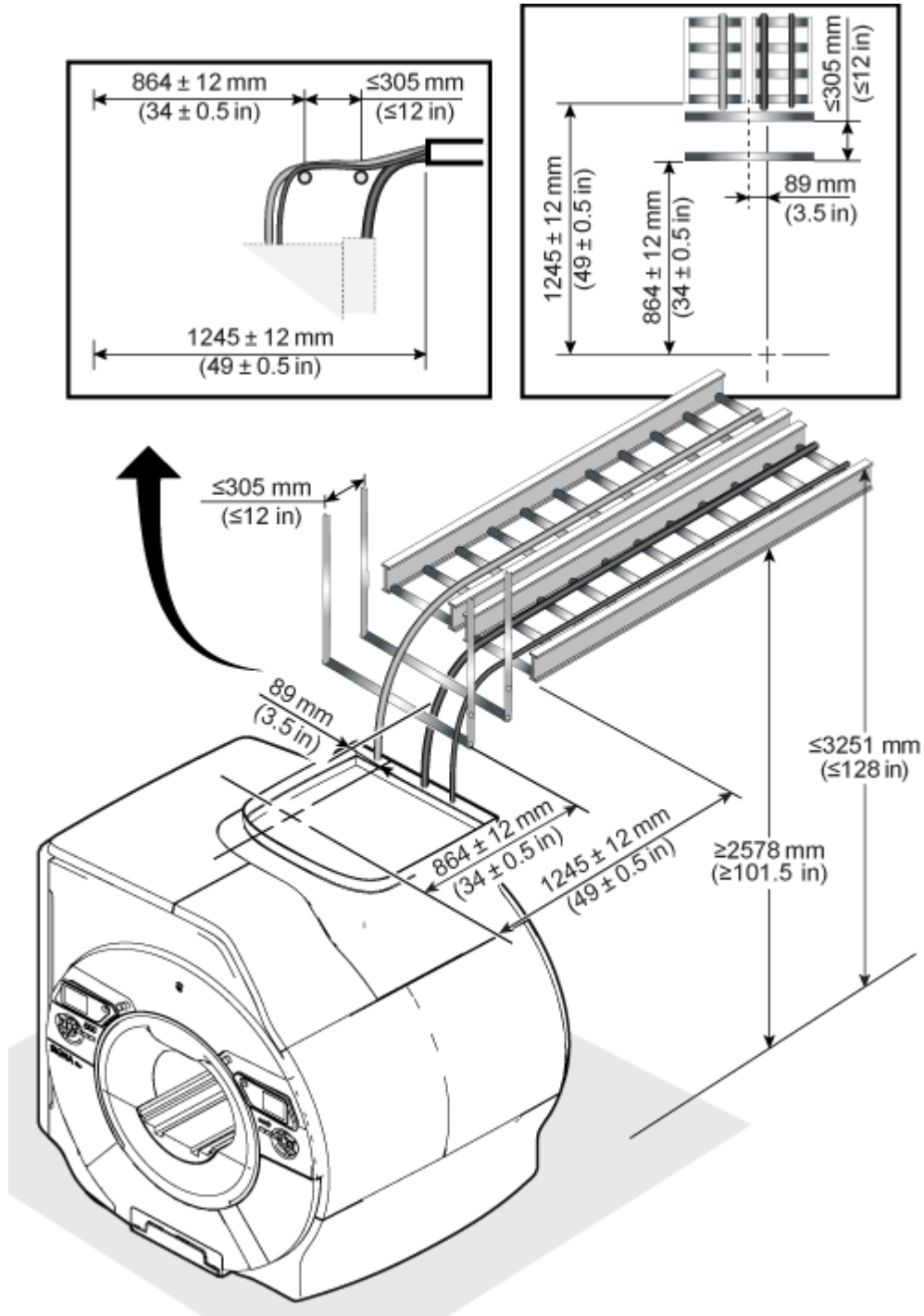

Figure 7-8 Cable Tray Requirements Example (Stacked)

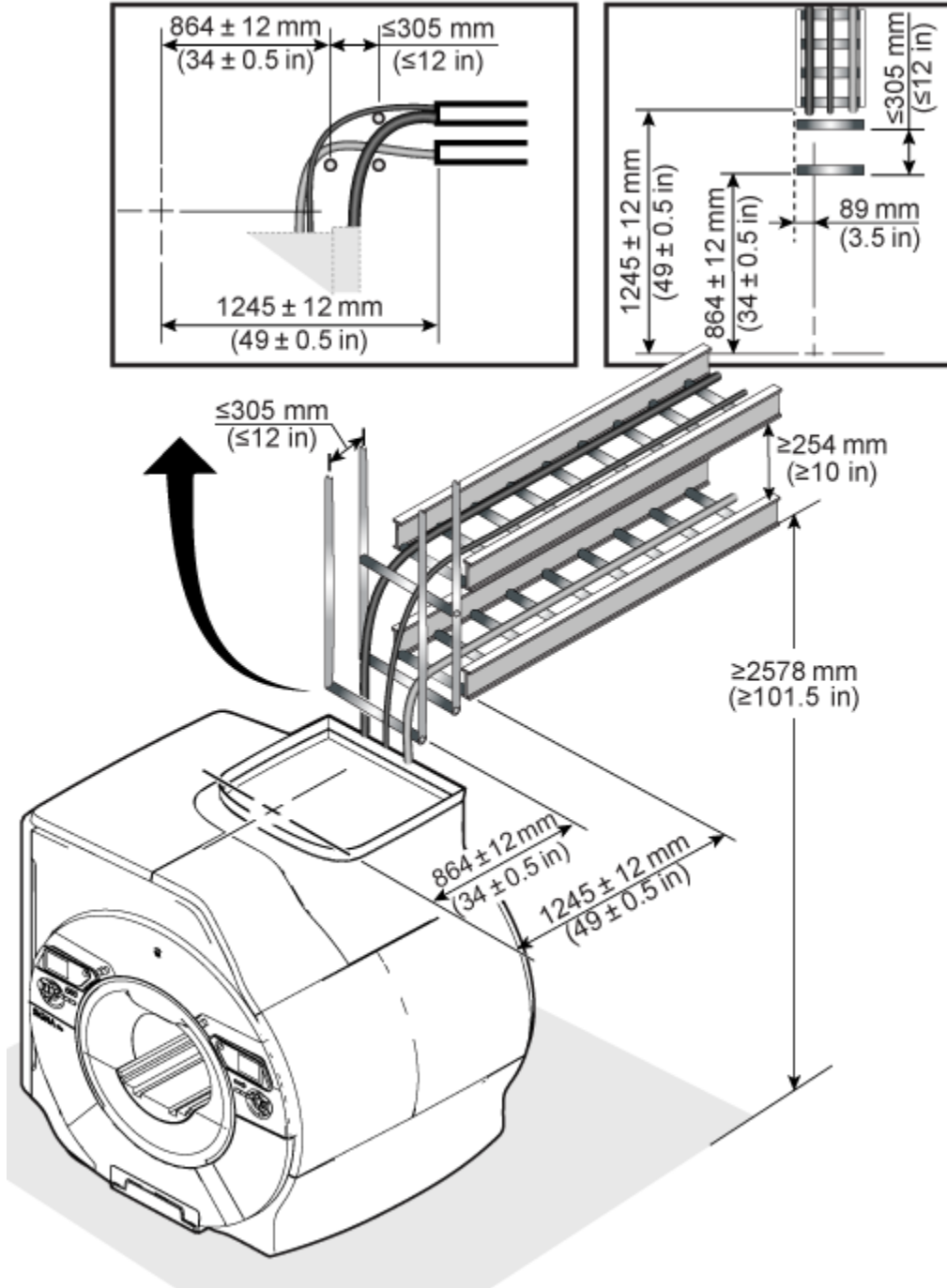
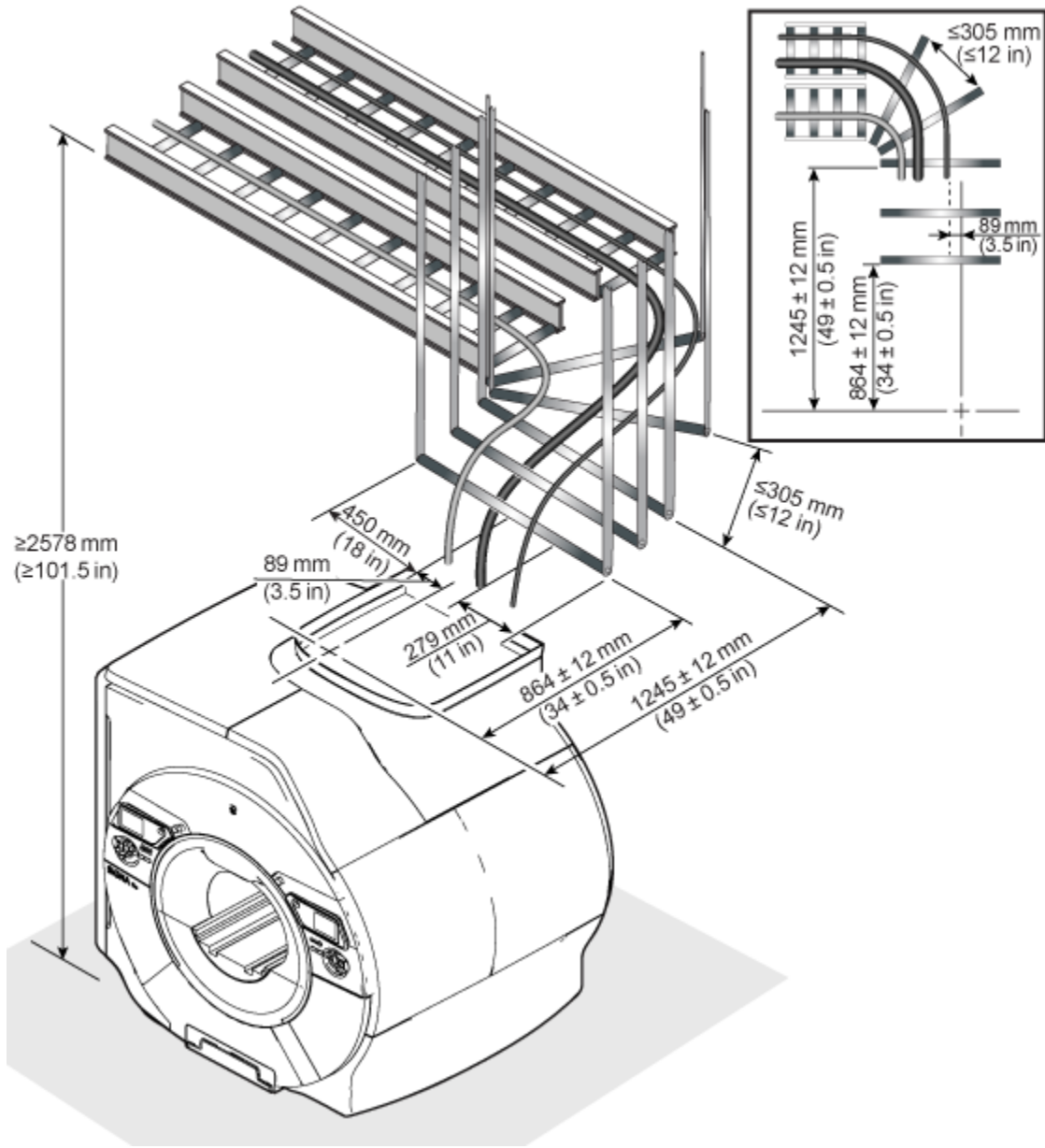

Figure 7-9 Cable Tray Requirements Example (90° Magnet Interface)



7.2.5 Penetration Panel Closet Requirements

1. The cable support must be positioned to prevent cables from resting on the top of the Penetration Panel Closet. The support must end 560 mm (22 in.) in front of the Penetration Panel.
2. The gradient cable support height and distance from the Penetration Panel must support a minimum cable bend radius of 330 mm (13 in.) to accommodate gradient cables.

7.2.6 Equipment Room Requirements

1. All equipment interconnects must route overhead.
2. Cables or hoses must drop through the bottom or off the end of the cable support directly to the top of the cabinets (see individual components in Chapter 4 for height requirements).
3. Cable supports do not have minimum height restrictions except above Equipment Room components. Refer to [Figure 4-3 Integrated System Cabinet \(ISC\) on page 85](#) and [Figure 4-7 Integrated Cooling Cabinet \(ICC\) on page 89](#) for the service restrictions above the cabinets.
4. Excess cable length must be stored in the Equipment Room.
5. For multiple MR System installations, cables from different MR Systems must not share the same cable support.
6. The table below lists the minimum width for cable trays between Equipment Room (and Operator Workspace) components.

Table 7-8 Minimum Cable Tray Width

	ISC		ICC		OW
	Electrical	Air and Water	Electrical	Air and Water	Electrical
ICC	76 mm (3 in.)	102 mm (4 in.)	N/A	N/A	N/A
OW	76 mm (3 in.)	N/A	76 mm (3 in.)	N/A	N/A
ISC	NA	NA	76 mm (3 in.)	150 mm (6 in.)	76 mm (3 in.)
PP	300 mm (12 in.)	N/A	76 mm (3 in.)	300 mm (12 in.)	76 mm (3 in.)

7.3 Facility-Supplied System Interconnects Specifications



On installation sites in China, make sure that the power cables and ground cables provided by customers have China Compulsory Certification (CCC). This information is supplied to the customer in China Power Cable Requirements, 5159493. (Go to the Customer Documentation Portal or contact the PMI.)

The following table lists the required facility-supplied system interconnects. Refer to [Figure 7-10 Facility-Supplied System Interconnects](#) on page 120 for additional information.

Table 7-9 Facility-Supplied System Interconnects

Group	Between Units		Comments	Requirements
	From	To		
C01	Facility Power	MDP	Facility Power and Ground	MR Suite Electrical Requirements on page 44
C02	MDP	ICC	Cryocooler Compressor Power (GE HealthCare supplied)	
C03	MDP	ISC	PDU Power	
	Facility Cooling Water	ICC	Cooling Water Supply	MR System Facility Water Requirements on page 37
	Facility Cooling Water	ICC	Cooling Water Return	
C04	Facility Network	MON	Facility must provide separate network access for the Magnet Monitor (MON), the Global Operator Cabinet (GOC) and the MDP. The MON connection must be available at all times.	Magnet Monitor (MON) Requirements and Specifications on page 92
	Facility Network	GOC		6.1 InSite RSvP (Remote Service Platform) Requirements on page 103
	Facility Network	Receptacle near MDP		4.2 Main Disconnect Panel (MDP) Requirements and Specifications on page 82
C05	MDP	E-Off Switch	Facility must supply cable from the MDP to the E-Off Switch in the Control Room.	MR Suite Electrical Requirements on page 44
	Facility Power	Outlet near MON	Facility outlet for MON power	MR Suite Electrical Requirements on page 44
C06	PP	E-Off Switch in Control Room or Equipment Room	Facility must supply additional wiring between the GE HealthCare supplied cable and the E-Off switch if the length needed is greater than the available length listed in MR System Interconnects Specifications on page 104.	MR Suite Electrical Requirements on page 44
	Facility Power	MRU	Facility power to MRU	Magnet Room Equipment Specifications on page 76

Table 7-9 Facility-Supplied System Interconnects (Table continued)

Group	Between Units		Comments	Requirements
	From	To		
	Facility Power	Service Receptacle	Receptacle to be installed in Magnet Room, using appropriate filter.	MR Suite Electrical Requirements on page 44
	Facility Power	Pneumatic Patient Alert	Facility Power to Pneumatic Patient Alert	MR Suite Electrical Requirements on page 44

Table 7-10 Optional Facility-Supplied System Interconnects

Group	From	To	Comments	Requirements
C01	Facility Power	Outlet near MRE	Facility outlet for MRE power (optional, not shown)	2.11 MR Suite Electrical Requirements on page 44
C01	Facility Power	Control room	Hardwired connection for OXY power (optional, not shown)	2.11 MR Suite Electrical Requirements on page 44
C01	Facility Power	Outlet near PAT Charging Station	Facility outlet for PAT Charging Station (optional, not shown)	2.11 MR Suite Electrical Requirements on page 44

Figure 7-10 Facility-Supplied System Interconnects

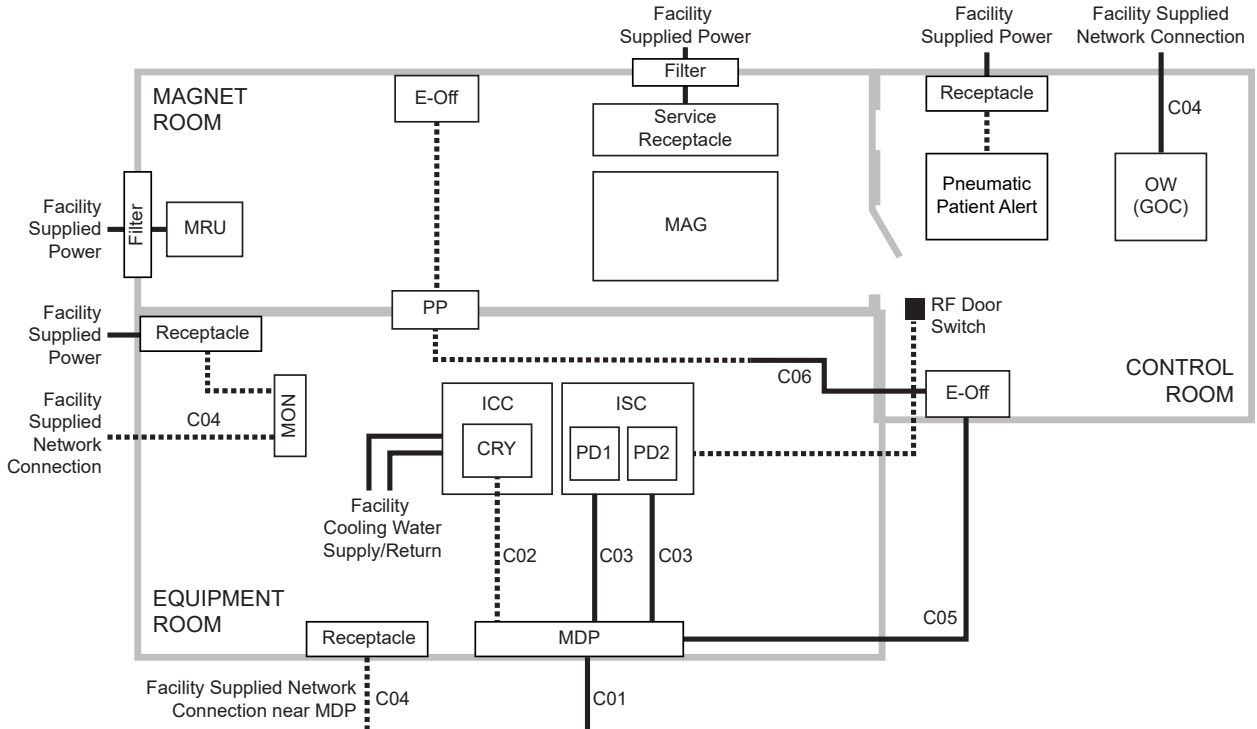

Legend			
—————	Facility supplied interconnect	GE HealthCare supplied interconnect

**NOTE**

- GE HealthCare recommends installing the RF Door switch on the outside wall of the Magnet Room.
- The illustration is not to scale and component positioning/interconnect runs are typical.
- Only GE HealthCare equipment interconnects are shown. Additional facility interconnects are required for non-GE HealthCare equipment (for example, Magnet Room DC Lighting).
- The E-Off button placement and cable routing shown indicates one possible configuration. Final E-Off button placement and cable routing is the responsibility of the customer. Refer to [2.11.1 General Electrical Requirements on page 44](#) for requirements for E-Off button placement.

The RF Shielded Room Vendor is responsible for installing the RF door switches. Refer to *RF Shielded Room Requirements*, 5850260-1EN.

8 Appendix

8.1 Glossary



Cryogen

A substance for producing low temperatures. Liquid helium is the cryogen used to cool the magnet to approximately 4 K (-269°C or -452°F).

Dewar

A container with an evacuated space between two highly reflective walls used to keep low temperature substances at near-constant temperatures. Liquid helium is usually stored and shipped in dewars.

Ferrous Material

Any substance containing iron which is strongly attracted by a magnetic field.

Gauss (G)

A unit of magnetic flux density. The earth's magnetic field strength is approximately one half Gauss to one Gauss depending on location. The internationally accepted unit is the tesla (1 tesla = 10000 G and 1 millitesla = 10 G).

Homogeneity

Uniformity. The homogeneity of the static magnetic field is an important quality of the magnet.

Isocenter

Center of the imaging volume ideally located at the magnet center.

Isogauss Line

A line on a field plot connecting identical magnetic field strength points.

Magnetic Field

A condition in a region of space established by the presence of a magnet and characterized by the presence of a detectable magnetic force at every point in the region. A magnetic field exists in the space around a magnet (or current carrying conductor) and can produce a magnetizing force on a body within it.

Magnetic Resonance (MR)

The absorption or emission of electromagnetic energy by nuclei in a static magnetic field, after excitation by a suitable radio frequency field.

Magnetic Shielding

Using material (for example, steel) to redistribute a magnetic field, usually to reduce fringe fields.

Quench

Condition when a superconducting magnet becomes resistive thus rapidly boiling off liquid helium. The magnetic field reduces rapidly after a quench.

Radio Frequency (RF)

Frequency intermediate between audio frequency and infrared frequencies. Used in magnetic resonance systems to excite nuclei.

Radio Frequency Shielding

Using material (for example, copper, aluminum, or steel) to reduce interference from external radio frequencies. A radio frequency shielded room usually encloses the entire Magnet Room.

Resonance

A large amplitude vibration caused by a relative small periodic stimulus of the same or nearly the same period as the natural vibration period of the system. In magnetic resonance imaging, the radio frequency pulses are the periodic stimuli which are at the same vibration period as the hydrogen nuclei being imaged.

Superconducting Magnet

A magnet whose magnetic field originates from current flowing through a superconductor. Such a magnet is enclosed in a cryostat.

Superconductor

A substance whose electrical resistance essentially disappears at temperatures near zero Kelvin. A commonly used superconductor in magnetic resonance imaging system magnets is niobium-titanium embedded in a copper matrix.

Tesla

The internationally accepted unit of magnetic flux density. One tesla is equal to 10000 Gauss. One millitesla is equal to 10 Gauss.

Waveguide

A hollow linear structure used in components such as the penetration wall to route cables and hoses, while limiting and controlling electromagnetic waves from entering the Magnet Room.

8.2 MR Site Vibration Test Guidelines



(Applies to all subsections within this section)

8.2.1 Test Measurements

1. Vibration measurements must be in the range of 10^{-6} g. Test equipment must have the required sensitivity to these levels.
2. Instrumentation must have a low tolerance to temperature effects since many times the low frequency thermal drift may influence the measurements.
3. All measured data must be acquired real time. Recording of vibration data will not allow for a correct site survey, specifically when studying transient vibration and when searching for specific vibration sources.
4. All analyses must be narrow-band Fast Fourier Transforms (FFT) over the frequency bands listed in [Table 8-1 Frequency Bands for FFT on page 124](#).
5. Time histories of the vibration must be recorded as acceleration levels vs. time. The resolution of the time history must be adjusted to clearly capture the transient event. The analyzer set-up will be site dependent and, in special cases, vibration response dependent. It is the responsibility of the vibration consultant to study the transient environment, capture data to confirm that transient activity exceeds the trigger level, then expand the time history data to exhibit the structural response.

Table 8-1 Frequency Bands for FFT

Frequency Band	Frequency Resolution
0.2 to 50 Hz	$\Delta f = 0.125$ Hz

8.2.2 Equipment (Spectral Analyzer) Set-Up

1. Frequency average should be a minimum of 20 linear averages (Do not use peak hold or 1/3 octave analysis).
2. Average and store should be a minimum of 20 plots steady state and 20 plots transient to support the consistency of the site vibrations.
3. Hanning windows must be applied to the entire spectra.
4. Spectrum analyzers capable of these measurements are readily available for purchase or rental. Models, such as the HP 3560A, Nicolet Phaszer, B&K Pulse, and HP 35670, are all capable of making the site vibration measurements. Accelerometers must have the capability to measure from 0.2 Hz beyond 50 Hz. Time histories can be recorded using any of the analyzers listed above.



NOTE

The equipment mentioned is for example only. It is the responsibility of the Engineering Test Firm to provide equipment that will allow measurements compliant with this guideline.

8.2.3 Data Collection

8.2.3.1 Ambient Baseline Condition

1. All of the measurements listed above must be made in a “quiet” environment—that is, areas where excessive traffic, subway trains, and so on, do not exist. A vibration measurement must also be made during periods without traffic or during periods of light traffic. Measurements must define the lowest levels of vibration possible at the site.
2. The source of any steady state vibration, whose level exceeds the magnet specifications found in [Magnet Room Structural Requirements on page 60](#), must be identified. A second measurement should be made with all of the identified contributors powered down if possible. In situations where it is not possible to power down equipment, vibration data must be collected to identify the specific source of the vibration concern. The majority of steady state vibration problems can be negated by isolating the vibration source.

8.2.3.2 Normal Condition

1. All of the vibration measurements listed above must be repeated during periods of “normal” environmental conditions, including the Fast Fourier Transforms (FFTs) and time histories. The transient measurements must be provided to define the dynamic disturbances the MR System may be exposed to. Transient analysis is required for a true assessment of the site.
2. Special attention must be paid to the site assessment during the entire analysis. Since transient vibration is not easily addressed once the MR suite is fully constructed, the test consultant must fully understand the needs for this analysis. The source of any transient vibration must be identified and supported with vibration plots. If the source of any transient vibration is not locatable, it is recommended that the customer have an alternate location identified and the vibration studied.
3. Transient vibration can be difficult to assess if the details are not understood. The **0.0005 g, zero-to-peak trigger level** is a starting point to understanding the vibration stability. The transient vibration peak amplitude, structural (time variant) response, decay rate and an estimate of the number of events per unit of time would constitute a complete transient analysis. All transient failures must be supported by time history plots. The plots must clearly show the structural response, the frequency of the signature and the decay rate. From this data, GE HealthCare can help determine compliance with the vibration guidelines.
4. The test consultant must provide site data to show the design recommendations for all sites/building structures meet the magnet specifications found in [Magnet Room Structural Requirements on page 60](#).

8.2.4 Presentation/Interpretation of Results

1. The recommended format for site vibration data collection, presentation, and analysis is demonstrated in the examples in [Figure 8-1 Example of Site Environmental Vibration Levels on page 126](#), [Figure 8-3 Acceleration Time History on page 127](#), and [Figure 8-4 Acceleration Time History \(Zoomed In on Transient Event\) on page 128](#). Presentation of the data in any other format (linear units only) may result in incorrect interpretation and diagnosis of the site. Additional data collection or presentation methods are at the option of the vibration testing service.

2. All plots must be properly annotated with:
 - 2.1. Instrumentation setup including number of averages, frequency resolution, and so on
 - 2.2. Test location
 - 2.3. Test conditions:
 - 2.3.1. Steady state
 - 2.3.2. Transient
 - 2.3.3. Heel drop
 - 2.3.4. Normal environment
 - 2.3.5. Typical traffic
 - 2.3.6. Any other conditions necessary to demonstrate understanding of potential sources of vibration
3. The customer's vibration testing service is responsible for interpreting the results and determining if that site meets GE HealthCare specifications.
4. If the vibration levels are too high, additional data acquisition may be necessary to:
 - 4.1. Determine the source of the vibration
 - 4.2. Propose a solution to the problem
 - 4.3. Find an alternate site location
5. Any questions regarding test equipment requirements, test parameters, or general questions should be discussed with the GE HealthCare Project Manager of Installation (PMI).

Figure 8-1 Example of Site Environmental Vibration Levels

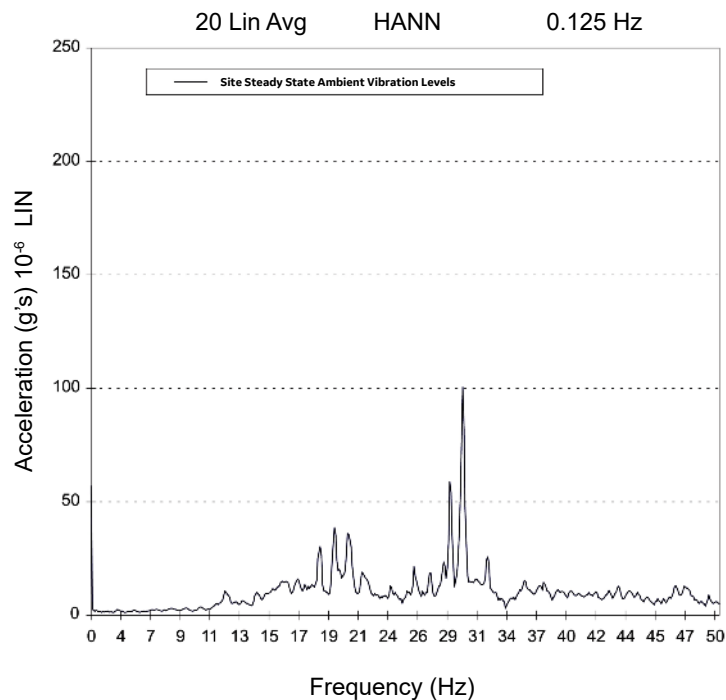

Figure 8-2 Example Site Environmental Vibration

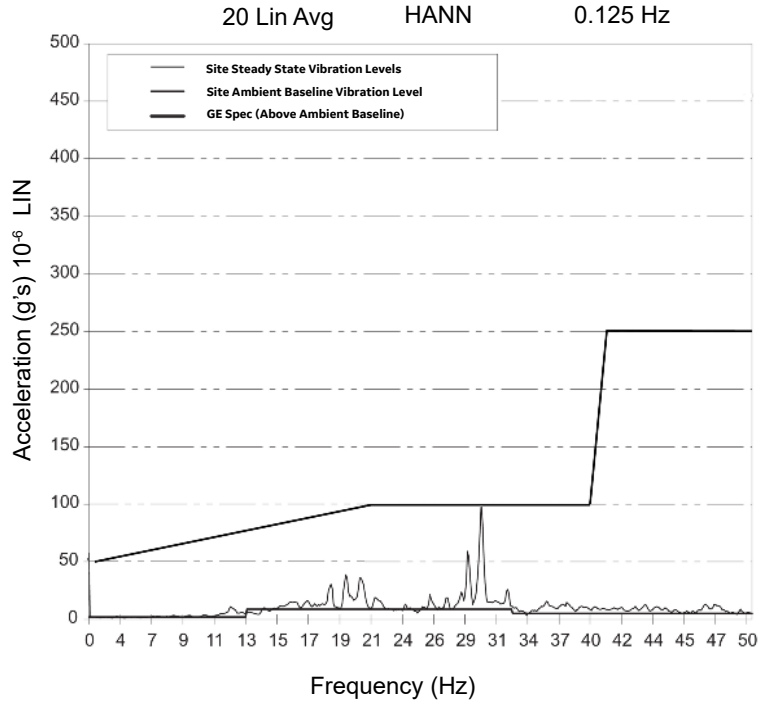

Figure 8-3 Acceleration Time History

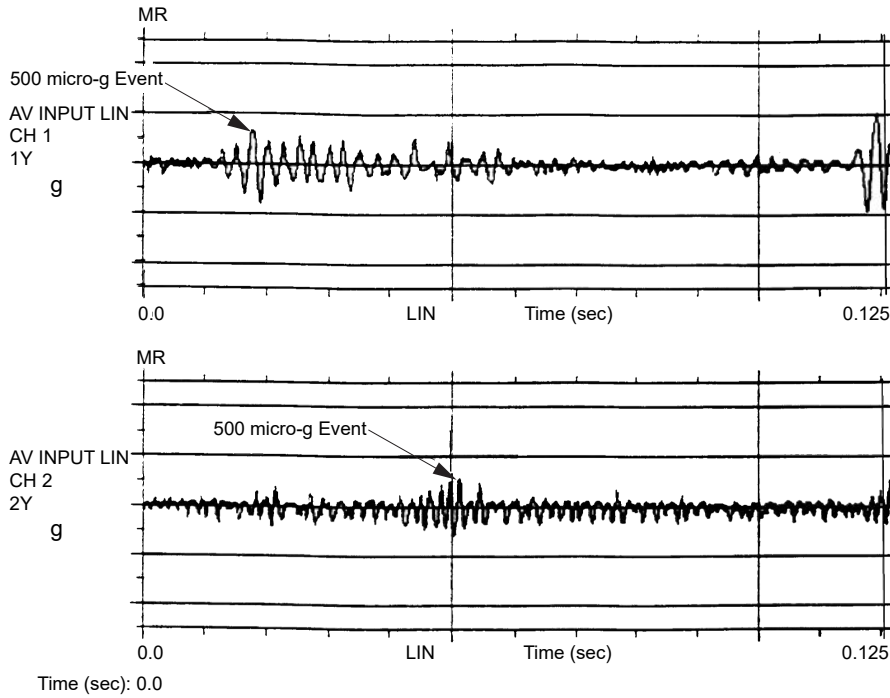
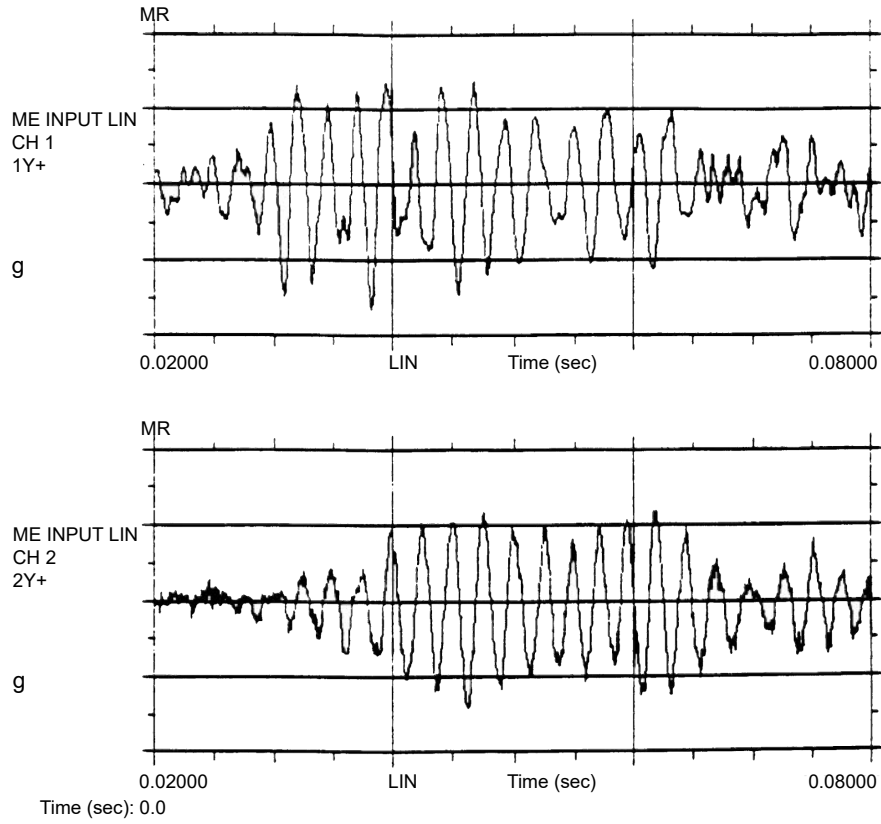

Figure 8-4 Acceleration Time History (Zoomed In on Transient Event)



8.3 Sample Calculation AC Power Equipment Minimum Distance



This is a sample calculation to determine minimum distance from a feeder, transformer, or other AC electrical source, using the formula found in [2.7.3 Electrical Current on page 31](#) to determine minimum distance from a feeder, transformer, or other AC electrical source.

$$I \text{ (amps)} = 20x^2 \text{ (meters)} \div S \text{ (meters)}$$

Note that the formula has three variables. If you have two of them, you can calculate the third. In this example, we calculate the minimum distance **x** from the source—in this case, a main electrical feeder carrying 450 amps of current in a 127 mm (5 in.) conduit.

Rearranging:	$x^2 = \frac{I \times S}{20}$ $x = \sqrt{\frac{I \times S}{20}}$
--------------	------------------------------------------------------------------

where:	
x	Minimum distance (in meters) from the feeder lines to isocenter of the magnet
I	Maximum allowable RMS single phase current (in amps) or maximum allowable RMS line current (in amps) in three phase feeder lines
S	Separation (in meters) between single phase conductors or greatest separation between three phase conductors

The separation **S** is the spacing between the conductors, and when all 3 conductors are run in a single conduit, **S** is simply the diameter of the conduit.

$$S = 5 \text{ inches} = 0.127 \text{ meters}$$

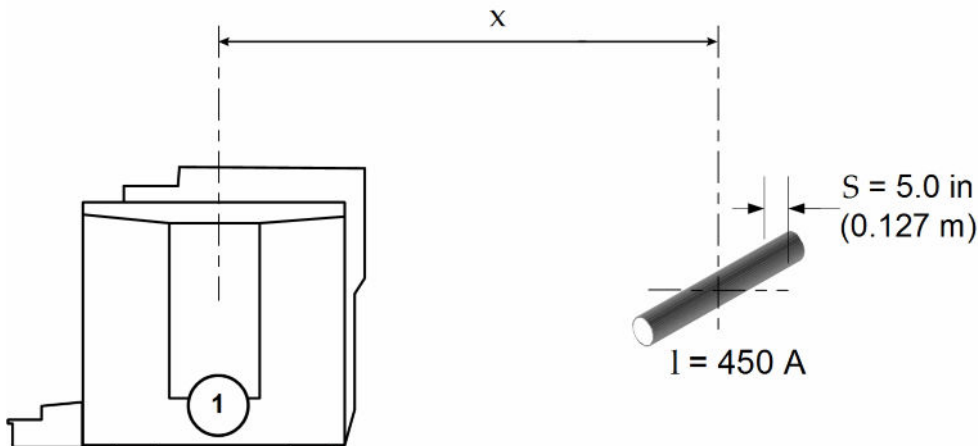

Item	Description
1	Magnet

$$x = \sqrt{\frac{450 \text{ A} \times 0.127 \text{ m}}{20}}$$

The conduit should be 1.7 m (5.6 ft.) from the magnet isocenter.

In other situations, the spacing **S** may be the spacing between HV feeders, the distance between transformer lugs, or the spacing between conduits when the phase conductors are run in separate conduits.

What if it is too close?

If this is an existing condition, you should request an *EMI study* to quantify the magnitude and direction of the AC disturbances. The calculation is worst-case and does not take into account the vector direction of the AC interference. The magnet is only sensitive to AC disturbances that are directed horizontally (magnet z-axis). Also, the calculation does not account for any magnetic shielding effect of steel conduit.

8.4 Selecting Anchor Size



The following is an example to illustrate the selection of correct anchors to install a magnet in a building with 13.8 MPa (2000 psi) concrete. For this example the area is not under seismic requirements.

1. Determine the magnet clamping force (for the Magnet: 11100 N + 900 N = 12000 N (2500 lb. + 200 lb. = 2700 lb.)).
2. Refer to the examples of anchor vendor catalogs below to select the anchor diameter and embedment that meets the clamping force (tension) determined in Step 1.

Diameter : ≥ 15.875 mm (0.625 in.) ≤ 31.75 mm (1.25 in.)

For 203 mm (8 in.) embedment select 19 mm (0.75 in.) diameter

For 114.3 mm (4.5 in.) embedment select 25.4 mm (1 in.) diameter

or

Diameter : Min. M16 Max. M32

For 130 mm embedment select M20 diameter

For 114 mm embedment select M24 diameter

3. The vendor instructions and torque to the maximum recommended level for the anchor selected in Step 2 must be provided to the RF shielded room vendor for correct installation of the anchor and equipment.

Table 8-2 Allowable Anchor Loads in Concrete (English Units)

Anchor Diameter mm (in.)	Embedment Depth mm (in.)	13.8 MPa (2000 psi)		20.7 MPa (3000 psi)		27.6 MPa (4000 psi)		41.4 MPa (6000 psi)	
		Tension kN (lb.)	Shear kN (lb.)	Tension kN (lb.)	Shear kN (lb.)	Tension kN (lb.)	Shear kN (lb.)	Tension kN (lb.)	Shear kN (lb.)
15.9 (5/8)	70 (2 3/4)	5.6 (1250)	12.5 (2800)	7.1 (1600)	13.7 (3070)	8.1 (1810)	14.8 (3300)	8.5 (1920)	12.5 (3330)
	102 (4)	8.3 (1870)	14.8 (3330)	10.7 (2400)	14.8 (3330)	13.0 (2930)	14.8 (3330)	14.2 (3200)	12.5 (3330)
	178 (7)	11.2 (2500)	14.8 (3330)	13.4 (3010)	14.8 (3330)	16.2 (3650)	14.8 (3330)	16.2 (3650)	12.5 (3330)
19.1 (3/4)	83 (3 1/4)	6.9 (1550)	12.8 (2880)	8.7 (1950)	14.7 (3310)	10.5 (2350)	16.6 (3730)	11.6 (2610)	21.4 (4800)
	121 (4 3/4)	11.2 (2510)	20.1 (4510)	14.5 (3250)	20.7 (4650)	17.2 (3870)	21.4 (4800)	20.8 (4670)	21.4 (4800)
	203 (8)	13.0 (2930)	21.4 (4800)	17.2 (3870)	21.4 (4800)	20.2 (4530)	21.4 (4800)	22.8 (5120)	21.4 (4800)

Table 8-2 Allowable Anchor Loads in Concrete (English Units) (Table continued)

Anchor Diameter mm (in.)	Embedment Depth mm (in.)	13.8 MPa (2000 psi)		20.7 MPa (3000 psi)		27.6 MPa (4000 psi)		41.4 MPa (6000 psi)	
		Tension kN (lb.)	Shear kN (lb.)	Tension kN (lb.)	Shear kN (lb.)	Tension kN (lb.)	Shear kN (lb.)	Tension kN (lb.)	Shear kN (lb.)
25.4 (1)	114 (4 1/2)	13.9 (3120)	27.0 (6080)	17.2 (3870)	30.1 (6770)	20.5 (4610)	33.2 (7470)	21.4 (4800)	33.2 (7470)
	152 (6)	19.6 (4400)	33.2 (7470)	28.5 (6400)	33.2 (7470)	32.0 (7200)	33.2 (7470)	32.6 (7330)	33.2 (7470)
	229 (9)	24.9 (5600)	33.2 (7470)	35.59 (8000)	33.2 (7470)	41.77 (9390)	33.2 (7470)	41.8 (9390)	33.2 (7470)



NOTE  All bolded values in this table fail to meet the clamping force (tension), and are therefore not acceptable anchors.

Table 8-3 Allowable Anchor Loads in Concrete (Metric Units)

Anchor Diameter	Embedment Depth mm (in.)	13.8 MPa (2000 psi)		20.7 MPa (3000 psi)		27.6 MPa (4000 psi)		41.4 MPa (6000 psi)	
		Tension kN (lb.)	Shear kN (lb.)	Tension kN (lb.)	Shear kN (lb.)	Tension kN (lb.)	Shear kN (lb.)	Tension kN (lb.)	Shear kN (lb.)
M16	105 (4 1/8)	11.2 (2500)	25.1 (5650)	20.9 (4705)	39.9 (8965)	24.2 (5450)	45.0 (10125)	30.7 (6900)	46.9 (10550)
M20	130 (5 1/8)	25.1 (5650)	52.9 (11900)	30.7 (6910)	58.7 (13195)	36.4 (8175)	64.5 (14490)	44.5 (10005)	64.5 (14490)
M24	155 (6 1/8)	30.0 (6735)	61.2 (13760)	36.9 (8300)	70.5 (15855)	43.9 (9860)	29.8 (17950)	57.7 (12980)	95.6 (21490)

NOTE  All bolded values in this table fail to meet the clamping force (tension), and are therefore not acceptable anchors.

8.5 Sample control schematic for customer-supplied MDP



This section provides an example of a control schematic for the auto-restart and Emergency Power Off (EPO) functions that meets the minimum GE HealthCare PIM requirements. This schematic does not include control, protection, wiring or devices that may be required due to local safety and regulatory requirements. Only the minimum equipment, devices and wiring is shown to meet the performance requirements of GE HealthCare equipment. The final MDP design must be compliant with applicable local codes and regulations.

Figure 8-5 Customer MDP control schematic

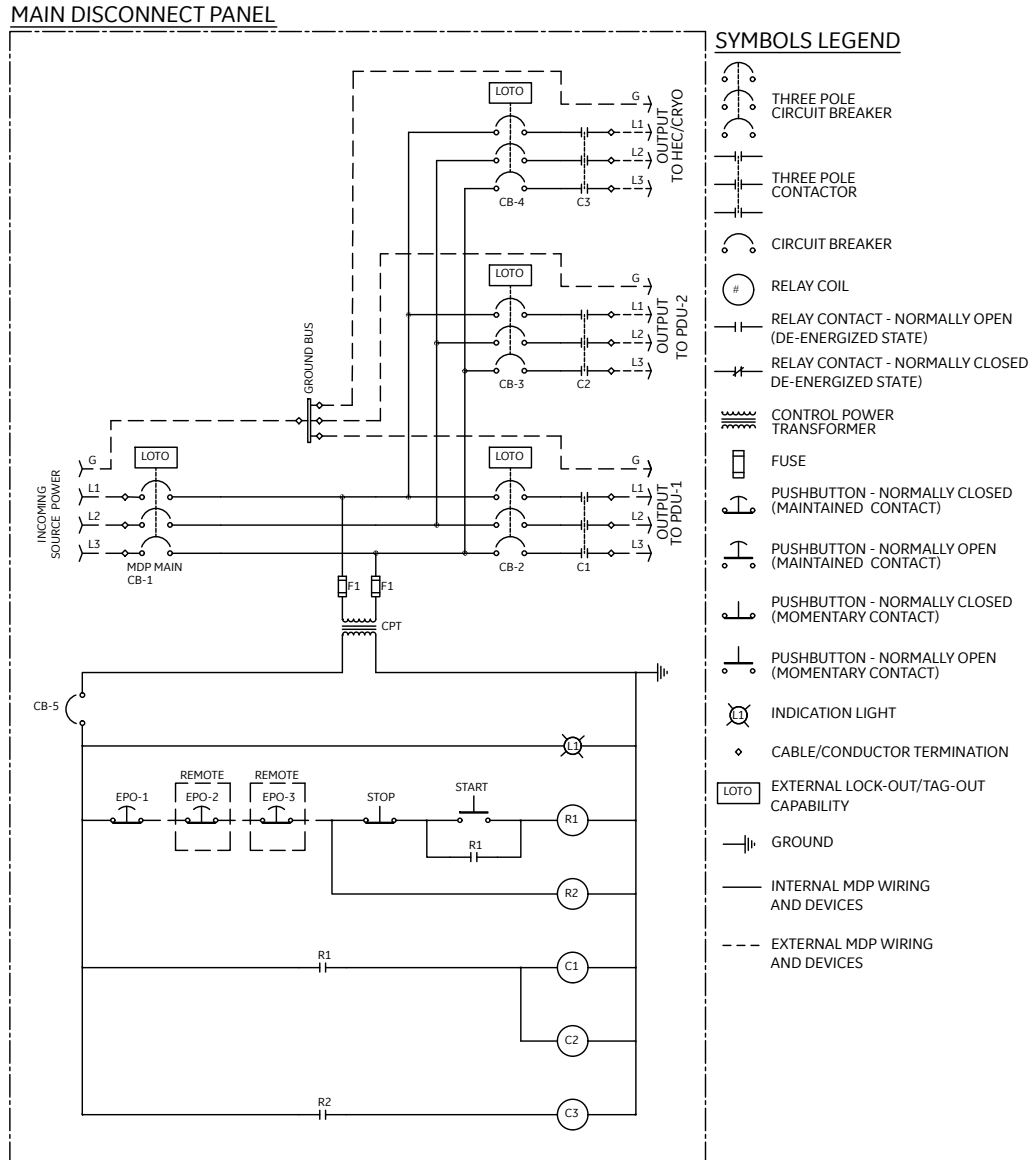

Revision History

Rev	Date	Description
English Document review and approval per DOC3108515		
2	November 2025	<ul style="list-style-type: none">• Section 1.1.3: Added safety considerations row• Section 1.1.5: Added one item for Digital Service and Connectivity Requirements• Section 2.1: Added this section Safety Considerations• Section 2.4: Added one common item for room size requirements• Section 2.11.3: Updated weight info• Section 3.6.1: Updated weight info• Section 7.1.2: Updated Table 7-3 Available Cable Lengths, Table 7-5 Available Cable Lengths for Gradient Cable and RF Cable (Magnet Room, Magnet Gradient Cable Strain Relief Plate to Pen Panel Top Edge)
1	July 2025	Initial Release



GE HealthCare

www.gehealthcare.com