



# **SIGNA Premier System**

## Pre-Magnet Delivery System Installation

5791338  
Revision 4



# Language Policy

## DOC0371395 - Global Language Procedure

ПРЕДУПРЕЖ ДЕНИЕ (BG)	<p>Това упътване за работа е налично само на английски език.</p> <ul style="list-style-type: none"> <li>Ако доставчикът на услугата на клиента изиска друг език, задължение на клиента е да осигури превод.</li> <li>Не използвайте оборудването, преди да сте се консултирали и разбрали упътването за работа.</li> <li>Неспазването на това предупреждение може да доведе до нараняване на доставчика на услугата, оператора или пациента в резултат на токов удар, механична или друга опасност.</li> </ul>
警告 (ZH-CN)	<p>本维修手册仅提供英文版本。</p> <ul style="list-style-type: none"> <li>如果客户的维修服务人员需要非英文版本，则客户需自行提供翻译服务。</li> <li>未详细阅读和完全理解本维修手册之前，不得进行维修。</li> <li>忽略本警告可能对维修服务人员、操作人员或患者造成电击、机械伤害或其他形式的伤害。</li> </ul>
警告 (ZH-HK)	<p>本服務手冊僅提供英文版本。</p> <ul style="list-style-type: none"> <li>倘若客戶的服務供應商需要英文以外之服務手冊，客戶有責任提供翻譯服務。</li> <li>除非已參閱本服務手冊及明白其內容，否則切勿嘗試維修設備。</li> <li>不遵從本警告或會令服務供應商、網絡供應商或病人受到觸電、機械性或其他形式的危險。</li> </ul>
警告 (ZH-TW)	<p>本維修手冊僅有英文版。</p> <ul style="list-style-type: none"> <li>若客戶的維修廠商需要英文版以外的語言，應由客戶自行提供翻譯服務。</li> <li>請勿試圖維修本設備，除非您已查閱並瞭解本維修手冊。</li> <li>若未留意本警告，可能導致維修廠商、操作員或病患因觸電、機械或其他危險而受傷。</li> </ul>
UPOZORENJE (HR)	<p>Ovaj servisni priručnik dostupan je na engleskom jeziku.</p> <ul style="list-style-type: none"> <li>Ako davatelj usluge klijenta treba neki drugi jezik, klijent je dužan osigurati prijevod.</li> <li>Ne pokušavajte servisirati opremu ako niste u potpunosti pročitali i razumjeli ovaj servisni priručnik.</li> <li>Zanemarite li ovo upozorenje, može doći do ozljede davatelja usluge, operatera ili pacijenta uslijed strujnog udara, mehaničkih ili drugih rizika.</li> </ul>
VÝSTRAHA (CS)	<p>Tento provozní návod existuje pouze v anglickém jazyce.</p> <ul style="list-style-type: none"> <li>V případě, že externí služba zákazníkům potřebuje návod v jiném jazyce, je zajištění překladu do odpovídajícího jazyka úkolem zákazníka.</li> <li>Nesnažte se o údržbu tohoto zařízení, aniž byste si přečetli tento provozní návod a pochopili jeho obsah.</li> <li>V případě nedodržování této výstrahy může dojít k poranění pracovníka prodejního servisu, obslužného personálu nebo pacientů vlivem elektrického proudu, respektive vlivem mechanických či jiných rizik.</li> </ul>
ADVARSEL (DA)	<p>Denne servicemanual findes kun på engelsk.</p> <ul style="list-style-type: none"> <li>Hvis en kundes tekniker har brug for et andet sprog end engelsk, er det kundens ansvar at sørge for oversættelse.</li> <li>Forsøg ikke at servicere udstyret uden at læse og forstå denne servicemanual.</li> <li>Manglende overholdelse af denne advarsel kan medføre skade på grund af elektrisk stød, mekanisk eller anden fare for teknikeren, operatøren eller patienten.</li> </ul>

<p>WAARSCHUWING (NL)</p>	<p>Deze onderhoudshandleiding is enkel in het Engels verkrijgbaar.</p> <ul style="list-style-type: none"> <li>Als het onderhoudspersoneel een andere taal vereist, dan is de klant verantwoordelijk voor de vertaling ervan.</li> <li>Probeer de apparatuur niet te onderhouden alvorens deze onderhoudshandleiding werd geraadpleegd en begrepen is.</li> <li>Indien deze waarschuwing niet wordt opgevolgd, zou het onderhoudspersoneel, de operator of een patiënt gewond kunnen raken als gevolg van een elektrische schok, mechanische of andere gevaren.</li> </ul>
<p>WARNING (EN)</p>	<p>This service manual is available in English only.</p> <ul style="list-style-type: none"> <li>If a customer's service provider requires a language other than English, it is the customer's responsibility to provide translation services.</li> <li>Do not attempt to service the equipment unless this service manual has been consulted and is understood.</li> <li>Failure to heed this warning may result in injury to the service provider, operator or patient from electric shock, mechanical or other hazards.</li> </ul>
<p>HOIATUS (ET)</p>	<p>See teenindusjuhend on saadaval ainult inglise keeles.</p> <ul style="list-style-type: none"> <li>Kui klienditeeninduse osutaja nõuab juhendit inglise keelest erinevas keeles, vastutab klient tõlketeenuse osutamise eest.</li> <li>Ärge üritage seadmeid teenindada enne eelnevalt käesoleva teenindusjuhendiga tutvumist ja sellest aru saamist.</li> <li>Käesoleva hoiatuse eiramine võib põhjustada teenuseosutaja, operaatori või patsiendi vigastamist elektrilöögi, mehaanilise või muu ohu tagajärjel.</li> </ul>
<p>VAROITUS (FI)</p>	<p>Tämä huolto-ohje on saatavilla vain englanniksi.</p> <ul style="list-style-type: none"> <li>Jos asiakkaan huoltohenkilöstö vaatii muuta kuin englanninkielistä materiaalia, tarvittavan käännöksen hankkiminen on asiakkaan vastuulla.</li> <li>Älä yritä korjata laitteistoa ennen kuin olet varmasti lukenut ja ymmärtänyt tämän huolto-ohjeen.</li> <li>Mikäli tätä varoitusta ei noudateta, seurauksena voi olla huoltohenkilöstön, laitteiston käyttäjän tai potilaan vahingoittuminen sähköiskun, mekaanisen vian tai muun vaaratilanteen vuoksi.</li> </ul>
<p>ATTENTION (FR)</p>	<p>Ce manuel d'installation et de maintenance est disponible uniquement en anglais.</p> <ul style="list-style-type: none"> <li>Si le technicien d'un client a besoin de ce manuel dans une langue autre que l'anglais, il incombe au client de le faire traduire.</li> <li>Ne pas tenter d'intervenir sur les équipements tant que ce manuel d'installation et de maintenance n'a pas été consulté et compris.</li> <li>Le non-respect de cet avertissement peut entraîner chez le technicien, l'opérateur ou le patient des blessures dues à des dangers électriques, mécaniques ou autres.</li> </ul>
<p>WARNUNG (DE)</p>	<p>Diese Serviceanleitung existiert nur in englischer Sprache.</p> <ul style="list-style-type: none"> <li>Falls ein fremder Kundendienst eine andere Sprache benötigt, ist es Aufgabe des Kunden für eine entsprechende Übersetzung zu sorgen.</li> <li>Versuchen Sie nicht diese Anlage zu warten, ohne diese Serviceanleitung gelesen und verstanden zu haben.</li> <li>Wird diese Warnung nicht beachtet, so kann es zu Verletzungen des Kundendiensttechnikers, des Bedieners oder des Patienten durch Stromschläge, mechanische oder sonstige Gefahren kommen.</li> </ul>

ΠΡΟΕΙΔΟΠΟΙΗΣΗ (EL)	<p>Το παρόν εγχειρίδιο σέρβις διατίθεται στα αγγλικά μόνο.</p> <ul style="list-style-type: none"> <li>Εάν το άτομο παροχής σέρβις ενός πελάτη απαιτεί το παρόν εγχειρίδιο σε γλώσσα εκτός των αγγλικών, αποτελεί ευθύνη του πελάτη να παρέχει υπηρεσίες μετάφρασης.</li> <li>Μην επιχειρήσετε την εκτέλεση εργασιών σέρβις στον εξοπλισμό εκτός εάν έχετε συμβουλευτεί και έχετε κατανοήσει το παρόν εγχειρίδιο σέρβις.</li> <li>Εάν δεν λάβετε υπόψη την προειδοποίηση αυτή, ενδέχεται να προκληθεί τραυματισμός στο άτομο παροχής σέρβις, στο χειριστή ή στον ασθενή από ηλεκτροπληξία, μηχανικούς ή άλλους κινδύνους.</li> </ul>
FIGYELMEZTETÉS (HU)	<p>Ezen karbantartási kézikönyv kizárólag angol nyelven érhető el.</p> <ul style="list-style-type: none"> <li>Ha a vevő szolgáltatója angoltól eltérő nyelvre tart igényt, akkor a vevő felelőssége a fordítás elkészítése.</li> <li>Ne próbálja elkezdni használni a berendezést, amíg a karbantartási kézikönyvben leírtakat nem értelmezték.</li> <li>Ezen figyelmeztetés figyelmen kívül hagyása a szolgáltató, működtető vagy a beteg áramütés, mechanikai vagy egyéb veszélyhelyzet miatti sérülését eredményezheti.</li> </ul>
AÐVÖRUN (IS)	<p>Þessi þjónustuhandbók er aðeins fánleg á ensku.</p> <ul style="list-style-type: none"> <li>Ef að þjónustuveitandi viðskiptamanns þarfnast annas tungumáls en ensku, er það skylda viðskiptamanns að skaffa tungumálþjónustu.</li> <li>Reynið ekki að afgreiða tækið nema að þessi þjónustuhandbók hefur verið skoðuð og skilin.</li> <li>Brot á sinna þessari aðvörun getur leitt til meiðsla á þjónustuveitanda, stjórnanda eða sjúklings frá raflosti, vélrænu eða öðrum áhættum.</li> </ul>
AVVERTENZA (IT)	<p>Il presente manuale di manutenzione è disponibile soltanto in lingua inglese.</p> <ul style="list-style-type: none"> <li>Se un addetto alla manutenzione richiede il manuale in una lingua diversa, il cliente è tenuto a provvedere direttamente alla traduzione.</li> <li>Procedere alla manutenzione dell'apparecchiatura solo dopo aver consultato il presente manuale ed averne compreso il contenuto.</li> <li>Il mancato rispetto della presente avvertenza potrebbe causare lesioni all'addetto alla manutenzione, all'operatore o ai pazienti provocate da scosse elettriche, urti meccanici o altri rischi.</li> </ul>
警告 (JA)	<p>このサービスマニュアルには英語版しかありません。</p> <ul style="list-style-type: none"> <li>サービスを担当される業者が英語以外の言語を要求される場合、翻訳作業はその業者の責任で行うものとさせていただきます。</li> <li>このサービスマニュアルを熟読し理解せずに、装置のサービスを行わないでください。</li> <li>この警告に従わない場合、サービスを担当される方、操作員あるいは患者さんが、感電や機械的又はその他の危険により負傷する可能性があります。</li> </ul>
경고 (KO)	<p>본 서비스 매뉴얼은 영어로만 이용하실 수 있습니다.</p> <ul style="list-style-type: none"> <li>고객의 서비스 제공자가 영어 이외의 언어를 요구할 경우, 번역 서비스를 제공하는 것은 고객의 책임입니다.</li> <li>본 서비스 매뉴얼을 참조하여 숙지하지 않은 이상 해당 장비를 수리하려고 시도하지 마십시오.</li> <li>본 경고 사항에 유의하지 않으면 전기 쇼크, 기계적 위험, 또는 기타 위험으로 인해 서비스 제공자, 사용자 또는 환자에게 부상을 입힐 수 있습니다.</li> </ul>
BRĪDINĀJUMS (LV)	<p>Šī apkopes rokasgrāmata ir pieejama tikai angļu valodā.</p> <ul style="list-style-type: none"> <li>Ja klienta apkopes sniedzējam nepieciešama informācija citā valodā, klienta pienākums ir nodrošināt tulkojumu.</li> <li>Neveiciet aprīkojuma apkopi bez apkopes rokasgrāmatas izlasīšanas un saprašanas.</li> <li>Šī brīdinājuma neievērošanas rezultātā var rasties elektriskās strāvas triecienu, mehānisku vai citu faktoru izraisītu traumu risks apkopes sniedzējam, operatoram vai pacientam.</li> </ul>

ĮSPĖJIMAS (LT)	<p>Šis eksploataavimo vadovas yra tik anglų kalba.</p> <ul style="list-style-type: none"> <li>• Jei kliento paslaugų tiekėjas reikalauja vadovo kita kalba – ne anglų, suteikti vertimo paslaugas privalo klientas.</li> <li>• Nemėginkite atlikti įrangos techninės priežiūros, jei neperskaitėte ar nesupratote šio eksploataavimo vadovo.</li> <li>• Jei nepaisysite šio įspėjimo, galimi paslaugų tiekėjo, operatoriaus ar paciento sužalojimai dėl elektros šoko, mechaninių ar kitų pavojų.</li> </ul>
ADVARSEL (NO)	<p>Denne servicehåndboken finnes bare på engelsk.</p> <ul style="list-style-type: none"> <li>• Hvis kundens serviceleverandør har bruk for et annet språk, er det kundens ansvar å sørge for oversettelse.</li> <li>• Ikke forsøk å reparere utstyret uten at denne servicehåndboken er lest og forstått.</li> <li>• Manglende hensyn til denne advarselen kan føre til at serviceleverandøren, operatøren eller pasienten skades på grunn av elektrisk støt, mekaniske eller andre farer.</li> </ul>
OSTRZEŻENIE (PL)	<p>Niniejszy podręcznik serwisowy dostępny jest jedynie w języku angielskim.</p> <ul style="list-style-type: none"> <li>• Jeśli serwisant klienta wymaga języka innego niż angielski, zapewnienie usługi tłumaczenia jest obowiązkiem klienta.</li> <li>• Nie próbować serwisować urządzenia bez zapoznania się z niniejszym podręcznikiem serwisowym i zrozumienia go.</li> <li>• Niezastosowanie się do tego ostrzeżenia może doprowadzić do obrażeń serwisanta, operatora lub pacjenta w wyniku porażenia prądem elektrycznym, zagrożenia mechanicznego bądź innego.</li> </ul>
ATENÇÃO (PT-BR)	<p>Este manual de assistência técnica encontra-se disponível unicamente em inglês.</p> <ul style="list-style-type: none"> <li>• Se outro serviço de assistência técnica solicitar a tradução deste manual, caberá ao cliente fornecer os serviços de tradução.</li> <li>• Não tente reparar o equipamento sem ter consultado e compreendido este manual de assistência técnica.</li> <li>• A não observância deste aviso pode ocasionar ferimentos no técnico, operador ou paciente decorrentes de choques elétricos, mecânicos ou outros.</li> </ul>
ATENÇÃO (PT-PT)	<p>Este manual de assistência técnica só se encontra disponível em inglês.</p> <ul style="list-style-type: none"> <li>• Se qualquer outro serviço de assistência técnica solicitar este manual noutra idioma, é da responsabilidade do cliente fornecer os serviços de tradução.</li> <li>• Não tente reparar o equipamento sem ter consultado e compreendido este manual de assistência técnica.</li> <li>• O não cumprimento deste aviso pode colocar em perigo a segurança do técnico, do operador ou do paciente devido a choques eléctricos, mecânicos ou outros.</li> </ul>
ATENȚIE (RO)	<p>Acest manual de service este disponibil doar în limba engleză.</p> <ul style="list-style-type: none"> <li>• Dacă un furnizor de servicii pentru clienți necesită o altă limbă decât cea engleză, este de datoria clientului să furnizeze o traducere.</li> <li>• Nu încercați să reparați echipamentul decât ulterior consultării și înțelegerii acestui manual de service.</li> <li>• Ignorarea acestui avertisment ar putea duce la rănirea depanatorului, operatorului sau pacientului în urma pericolelor de electrocutare, mecanice sau de altă natură.</li> </ul>

ОСТОРОЖНО! (RU)	<p>Данное руководство по техническому обслуживанию представлено только на английском языке.</p> <ul style="list-style-type: none"> <li>• Если сервисному персоналу клиента необходимо руководство не на английском, а на каком-то другом языке, клиенту следует самостоятельно обеспечить перевод.</li> <li>• Перед техническим обслуживанием оборудования обязательно обратитесь к данному руководству и поймите изложенные в нем сведения.</li> <li>• Несоблюдение требований данного предупреждения может привести к тому, что специалист по техобслуживанию, оператор или пациент получит удар электрическим током, механическую травму или другое повреждение.</li> </ul>
UPOZORENJE (SR)	<p>Ovo servisno uputstvo je dostupno samo na engleskom jeziku.</p> <ul style="list-style-type: none"> <li>• Ako klijentov serviser zahteva neki drugi jezik, klijent je dužan da obezbedi prevodilačke usluge.</li> <li>• Ne pokušavajte da opravite uređaj ako niste pročitali i razumeli ovo servisno uputstvo.</li> <li>• Zanemarivanje ovog upozorenja može dovesti do povređivanja servisera, rukovaoca ili pacijenta usled strujnog udara ili mehaničkih i drugih opasnosti.</li> </ul>
UPOZORNENIE (SK)	<p>Tento návod na obsluhu je k dispozícii len v angličtine.</p> <ul style="list-style-type: none"> <li>• Ak zákazníkovi poskytovateľ služieb vyžaduje iný jazyk ako angličtinu, poskytnutie prekladateľských služieb je zodpovednosťou zákazníka.</li> <li>• Nepokúšajte sa o obsluhu zariadenia, kým si neprečítate návod na obsluhu a neporozumiete mu.</li> <li>• Zanedbanie tohto upozornenia môže spôsobiť zranenie poskytovateľa služieb, obsluhujúcej osoby alebo pacienta elektrickým prúdom, mechanické alebo iné ohrozenie.</li> </ul>
ATENCIÓN (ES)	<p>Este manual de servicio sólo existe en inglés.</p> <ul style="list-style-type: none"> <li>• Si el encargado de mantenimiento de un cliente necesita un idioma que no sea el inglés, el cliente deberá encargarse de la traducción del manual.</li> <li>• No se deberá dar servicio técnico al equipo, sin haber consultado y comprendido este manual de servicio.</li> <li>• La no observancia del presente aviso puede dar lugar a que el proveedor de servicios, el operador o el paciente sufran lesiones provocadas por causas eléctricas, mecánicas o de otra naturaleza.</li> </ul>
VARNING (SV)	<p>Den här servicehandboken finns bara tillgänglig på engelska.</p> <ul style="list-style-type: none"> <li>• Om en kunds servicetekniker har behov av ett annat språk än engelska, ansvarar kunden för att tillhandahålla översättningstjänster.</li> <li>• Försök inte utföra service på utrustningen om du inte har läst och förstår den här servicehandboken.</li> <li>• Om du inte tar hänsyn till den här varningen kan det resultera i skador på serviceteknikern, operatören eller patienten till följd av elektriska stötar, mekaniska faror eller andra faror.</li> </ul>
OPOZORILO (SL)	<p>Ta servisni priročnik je na voljo samo v angleškem jeziku.</p> <ul style="list-style-type: none"> <li>• Če ponudnik storitve stranke potrebuje priročnik v drugem jeziku, mora stranka zagotoviti prevod.</li> <li>• Ne poskušajte servisirati opreme, če tega priročnika niste v celoti prebrali in razumeli.</li> <li>• Če tega opozorila ne upoštevate, se lahko zaradi električnega udara, mehanskih ali drugih nevarnosti poškoduje ponudnik storitev, operater ali bolnik.</li> </ul>
DİKKAT (TR)	<p>Bu servis kılavuzunun sadece ingilizcesi mevcuttur.</p> <ul style="list-style-type: none"> <li>• Eğer müşteri teknisyeni bu kılavuzu ingilizce dışında bir başka lisandan talep ederse, bunu tercüme ettirmek müşteriye düşer.</li> <li>• Servis kılavuzunu okuyup anlamadan ekipmanlara müdahale etmeyiniz.</li> <li>• Bu uyarıya uyulmaması, elektrik, mekanik veya diğer tehlikelerden dolayı teknisyen, operatör veya hastanın yaralanmasına yol açabilir.</li> </ul>

ЗАСТЕРЕЖЕННЯ (УК)	<p>Даний посібник з експлуатації доступний тільки англійською мовою.</p> <ul style="list-style-type: none"><li>• Якщо постачальник послуг клієнта спілкується іноземною мовою, тоді клієнт зобов'язаний забезпечити переклад.</li><li>• Заборонено проводити огляд обладнання без попереднього звертання до даного посібника з експлуатації і розуміння інформації, поданої у ньому.</li><li>• Недотримання цього застереження може завдати шкоди здоров'ю постачальника послуг, оператора або пацієнта через ураження електричним струмом, механічну травму або інше ушкодження.</li></ul>
----------------------	---

# Contents

<b>Chapter 1 Getting started .....</b>	<b>11</b>
1.1 Preparing the site .....	11
1.2 System Components .....	12
1.2.1 Magnet Room .....	12
1.2.2 Equipment Room .....	12
1.2.3 Control Room .....	12
1.2.4 Accessories .....	12
1.2.5 System Overview.....	13
1.3 Doing an inspection of the product delivery.....	14
1.4 Pre-magnet delivery system installation workflow .....	16
<b>Chapter 2 Installing components .....</b>	<b>17</b>
2.1 Installing the Main Disconnect Panel (MDP).....	17
2.2 Doing a check that pen panel frames are installed.....	20
2.3 Preparing the Integrated Cooling Cabinet (ICC) or the Platform Integrated Cooling Cabinet (pICC) for the magnet installation .....	21
2.3.1 Uncrating and positioning the Integrated Cooling Cabinet (ICC) .....	22
2.3.1.1 Checking the level of the Integrated Cooling Cabinet (ICC).....	29
2.3.1.2 Connecting the cryocooler hoses and cables (equipment room) [Integrated Cooling Cabinet (ICC)].....	30
2.3.2 Uncrating and positioning the Platform Integrated Cooling Cabinet (pICC) .....	35
2.3.2.1 Checking the level of the Platform Integrated Cooling Cabinet (pICC) .....	42
2.3.2.2 Connecting the cryocooler hoses and cables (equipment room) [Platform Integrated Cooling Cabinet (pICC)].....	44
<b>Chapter 3 Completing the installation .....</b>	<b>53</b>
3.1 Making sure the pre-magnet delivery installation is complete.....	53
3.2 Completing the GE HealthCare Field Engineer responsibilities.....	53
<b>Revision History.....</b>	<b>55</b>

Page intentionally left blank

# Chapter 1 Getting started

## 1.1 Preparing the site

**Table 1-1 Required conditions**

Condition
Before equipment is delivered, you must complete pre-installation work to avoid delays and confusion. Refer to the <i>SIGNA™ Premier Preinstallation Manual (5815067)</i> .

**Table 1-2 Safety**

Safety
<p>Before working in any GE HealthCare MR suite or doing any GE HealthCare service procedure, you must:</p> <ul style="list-style-type: none"> <li>• Have read and understood all hazard conditions and safety requirements in the latest revision of the <i>GE HealthCare MR Service Safety Manual (5452735)</i>.</li> <li>• Have successfully completed all relevant GE HealthCare Environmental Health and Safety (EHS) courses (or for non-GE employees, equivalent workplace training courses).</li> <li>• Comply with all site-specific training and workplace safety requirements.</li> </ul> <p>If you have any safety concerns at any time, do not begin work or immediately stop work and move to a safe location. Immediately contact your supervisor or site safety officer for instructions on how to proceed.</p>

### Introduction

This manual provides instructions for positioning or installing the following components of the SIGNA Premier system prior to delivery and installation of the magnet.



#### IMPORTANT

Pre-magnet delivery items depend on the region. Perform installation only for the items shipped prior to magnet delivery.

- Main disconnect panel
- Pen panel frames
- Integrated Cooling Cabinet (ICC) (if shipped)

### System options

There is one system option that impacts site preparation: oxygen monitor.

### Facility options

The following facility options impact site preparation:

- SIGNA System Seismic Anchorage Service (R43900JE).

#### NOTE

Magnet seismic anchoring is the customer's responsibility to coordinate magnet mounting methods with the RF shielded room vendor to prevent RF leaks and secondary grounding problems.

## 1.2 System Components

### 1.2.1 Magnet Room

1. 3.0T Magnet and Magnet Enclosure (MAG) and Vibroacoustic Damping Kit
2. Patient Table (PT)
3. Magnet Rundown Unit (MRU)

**NOTE**

An optional remote MRU may be located outside the Magnet Room.

### 1.2.2 Equipment Room

1. Main Disconnect Panel (MDP) (may be customer-supplied in exempt regions)
2. Integrated System Cabinet (ISC)
3. Integrated Cooling Cabinet (ICC) (ICC refers to either ICC or pICC)
4. Integrated System Cabinet (ISC) Penetration Panel (PP)
5. Integrated Cooling Cabinet (ICC) Secondary Penetration Wall (SPW)
6. Magnet Monitor (MON)
7. Optional:
  - Magnetic Resonance Elastography (MRE)
  - Multi-Nuclear Spectroscopy (MNS)

### 1.2.3 Control Room

1. Operator Workspace equipment (OW)
2. Pneumatic Patient Alert System (PA1)
3. Optional:
  - Oxygen Monitor (OXY)
  - Physiological Acquisition Transceiver (PAT) Charging Station

### 1.2.4 Accessories

1. Patient accessories, including RF coils, phantoms, cushions, sponges, straps, and wedges

**NOTE**

**(For systems with RX29.0 and later software)** The phantom cart and the LVshim phantom side lobes are not used and are not delivered with the system.

2. Gating accessories, including patient cardiac leads, peripheral gating probe, and respiratory bellows

## 1.2.5 System Overview

Figure 1-1 System overview (example)

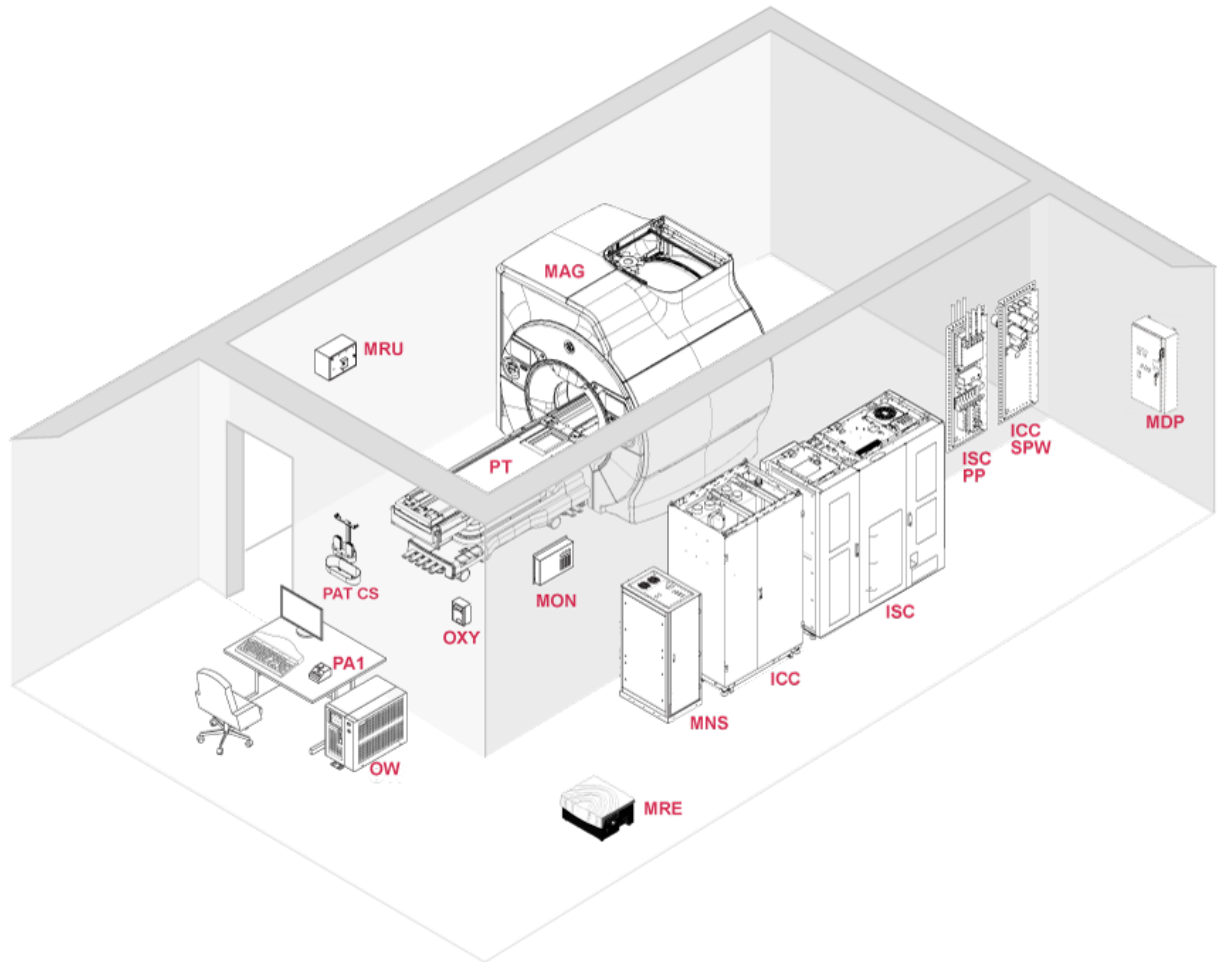

**NOTE**

MNS, MRE, PAT Charging Station and OXY shown above are optional components of the system.

## 1.3 Doing an inspection of the product delivery

### Prerequisites

**Table 1-3 Safety**

Safety
<p>Before working in any GE HealthCare MR suite or doing any GE HealthCare service procedure, you must:</p> <ul style="list-style-type: none"> <li>• Have read and understood all hazard conditions and safety requirements in the latest revision of the GE HealthCare <i>MR Service Safety Manual</i> (5452735).</li> <li>• Have successfully completed all relevant GE HealthCare Environmental Health and Safety (EHS) courses (or for non-GE employees, equivalent workplace training courses).</li> <li>• Comply with all site-specific training and workplace safety requirements.</li> </ul> <p>If you have any safety concerns at any time, do not begin work or immediately stop work and move to a safe location. Immediately contact your supervisor or site safety officer for instructions on how to proceed.</p>

### Procedure

1. Examine all packages closely at delivery. If damage is apparent, do the following:
  - 1.1. Make sure the notation *damage in shipment* is written on all copies of the freight or express bill before delivery is accepted or signed for by a GE HealthCare representative or a hospital receiving agent.
  - 1.2. Whether noted or concealed, you must report damage to the carrier immediately upon discovery, or in any event, within 14 days after receipt, and hold the contents and containers for inspection by the carrier. A transportation company will not pay a claim for damage if an inspection is not requested within this 14-day period.
  - 1.3. Call Global Parts at 1-800-548-3366 (option 6) to file a report of the damage.



#### **NOTE**

Contact your local service coordinator for more information on this process.

2. Make sure that all catalog numbers listed as delivered on the shipping document have been delivered.
3. If any catalogs and/or packing boxes are missing or noted as shipped short, identify the impact on the installation schedule.

4. Make sure each packing box is in the correct location based on the *Where Label* that is attached to the outside of the box.

**Figure 1-2 Packing box labels**

*Where Label*



*When Label*

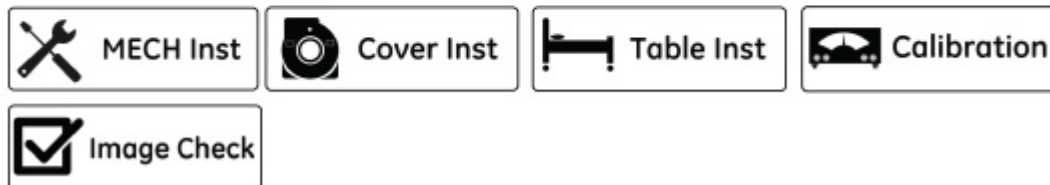

**NOTE**

The *When Label* identifies when to use the box.

5. If you are not sure about the contents of a box, refer to Product Delivery Instructions (PDIs) and packing lists to make sure the shipment is correct.



**NOTE**

PDIs specify box contents, part numbers, and shipping procedures, and are identified by catalog number. Lists of items included with each box are detailed in separate packing lists.

6. If the ICC has shipped, find the product locator card attached to the legacy ICC Top Asm (5599329) or the platform ICC Asm (5766221).
  - 6.1. At this time, for U.S. ONLY, the preferred method of submitting information is the FE Site Verification Web Site. The FE Site Verification consists of three components that are available on the web from the main menu. They are:
    - 6.1.1. Install/deinstall product locator model and serial numbers
    - 6.1.2. Add/modify ship to address information
    - 6.1.3. Update CARES FE data for primary/secondary FEs
  - 6.2. One "Shipping Card" is filled out and submitted when shipped (extra cards are supplied for trans-shipments between storage and distribution points), and the "Installation Card" and extra shipment cards are attached.



**NOTE**

Make sure that the serial and model number on each rating plate matches the installation card numbers before removing the installation card. Note that there may be one or more shipment cards and bar code labels with the installation card. These shipment cards are used to trace the transfer of serialized units between various inventory storage and distribution points until the product reaches its final installation destination. Process just the installation card and discard any extra shipment cards and labels.

# 1.4 Pre-magnet delivery system installation workflow

**Table 1-4 Required conditions**

Condition
All on-site construction must be complete before equipment is delivered and installation begins. Attempting to install the system while construction is being completed will impact installation efficiency and further delay site completion. Make sure that all pre-installation and construction work is completed before equipment is delivered to help make sure of an earlier turnover date.

Follow the workflow below to make sure of an orderly and efficient system installation. Note that many procedures may be performed in parallel and may be performed in any order according to the specific situation of each site.

This flowchart assumes that all system equipment was delivered together. Make sure that every part required is available before proceeding to the mechanical installation.

**Figure 1-3 Site installations required prior to system mechanical installation**

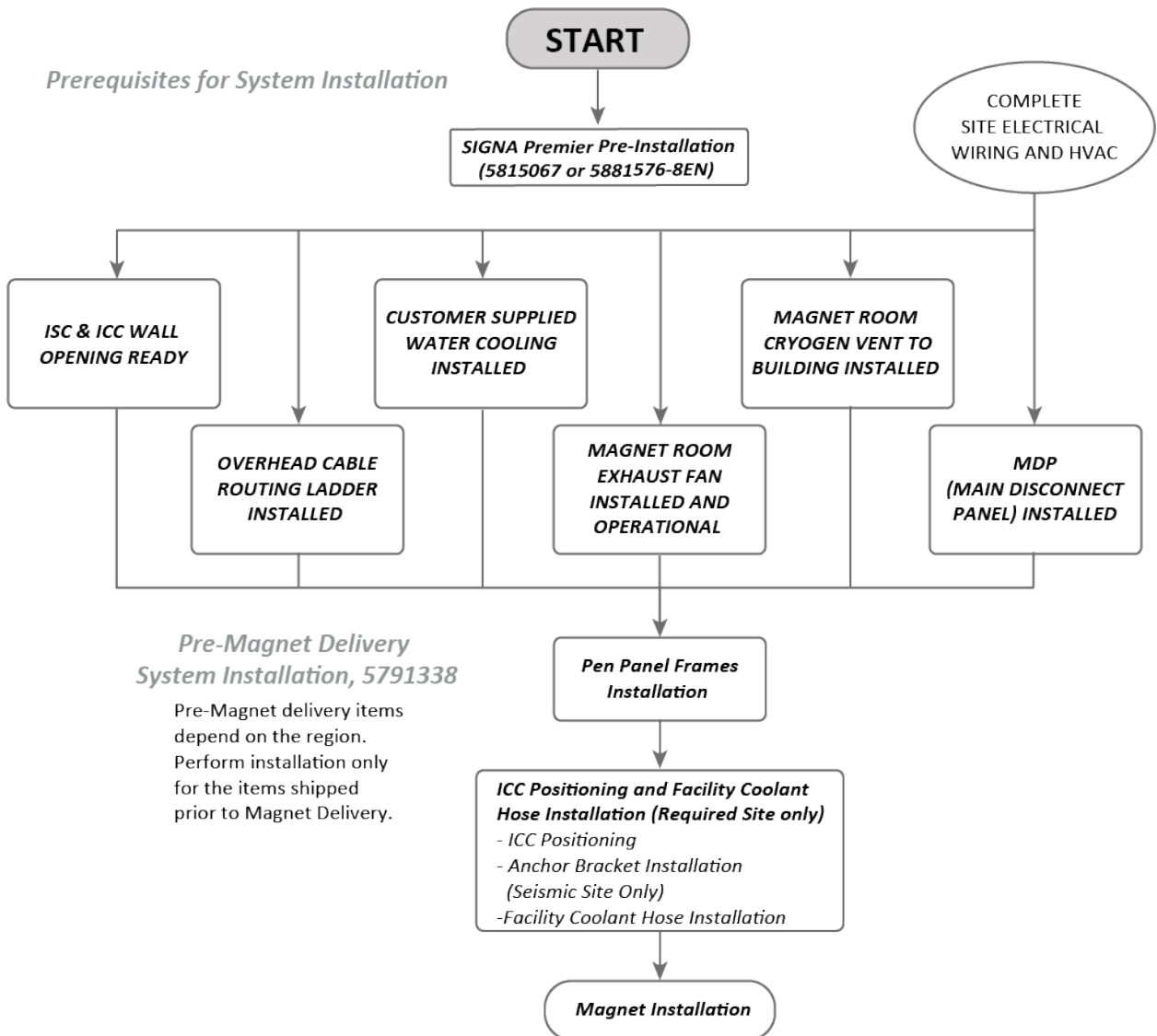

## Chapter 2 Installing components

### 2.1 Installing the Main Disconnect Panel (MDP)

#### Prerequisites

**Table 2-1 Personnel requirements**

Personnel requirements	
	<p><b>IMPORTANT</b> GE Field Engineers cannot install, service, or repair the MDP. Only a licensed electrician is qualified to complete these tasks. Refer to the MR Service Safety Manual (5452735) for further safety information.</p> <p>To service the MDP, the customer must provide a qualified electrician or other appropriate facility personnel who meets the electrical safety codes for their area.</p>

**Table 2-2 Safety**

<p>Before working in any GE HealthCare MR suite or doing any GE HealthCare service procedure, you must:</p> <ul style="list-style-type: none"> <li>• Have read and understood all hazard conditions and safety requirements in the latest revision of the GE HealthCare <i>MR Service Safety Manual</i> (5452735).</li> <li>• Have successfully completed all relevant GE HealthCare Environmental Health and Safety (EHS) courses (or for non-GE employees, equivalent workplace training courses).</li> <li>• Comply with all site-specific training and workplace safety requirements.</li> </ul> <p>If you have any safety concerns at any time, do not begin work or immediately stop work and move to a safe location. Immediately contact your supervisor or site safety officer for instructions on how to proceed.</p>
---

#### About this task

Have a customer electrician mount the MDP and connect it to a facility power source. Refer to architectural site layout drawings for specifications and mounting locations. You can find the MDP manual in the panel.

Figure 2-1 Main Disconnect Panel (MDP)





**NOTE**

This figure is for reference only and may not be specific to your product.

**Figure 2-2 System Main Disconnect Panel (MDP) Setup (refer to the table below for circuit breaker specifications)**

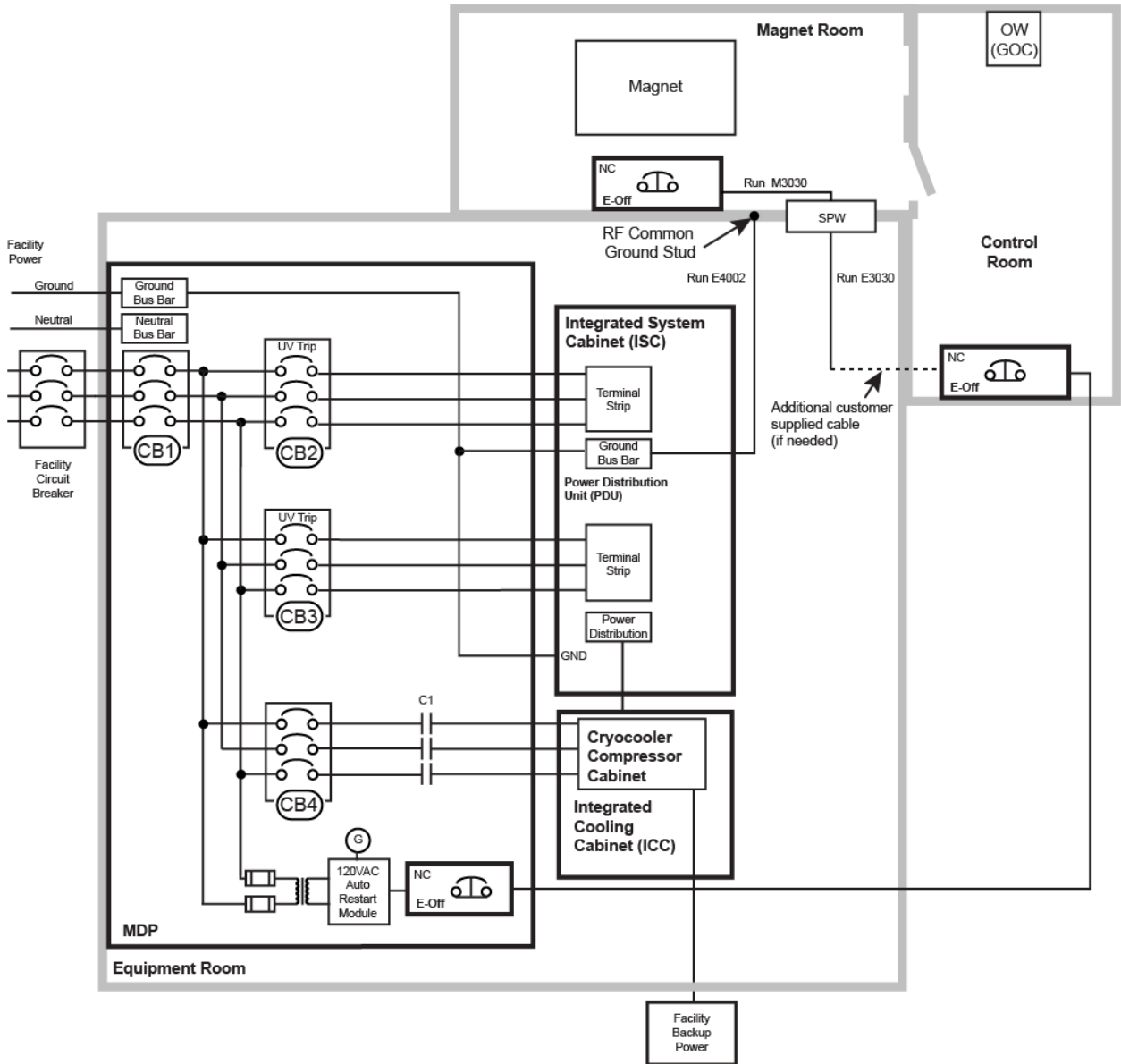

**Table 2-3 System Main Disconnect Panel (MDP) Setup**

Circuit Breaker (CB)	480 VAC	380/400/415 VAC
CB1	250A	350A
CB2	200A	250A
CB3	60A	80A
CB4	30A	30A

## 2.2 Doing a check that pen panel frames are installed

### Prerequisites

Personnel requirements			
Required persons	Preliminary requirements	Procedure	Finalization
1	-	2 minutes	-

**Table 2-4 Safety**

<p>Before working in any GE HealthCare MR suite or doing any GE HealthCare service procedure, you must:</p> <ul style="list-style-type: none"> <li>• Have read and understood all hazard conditions and safety requirements in the latest revision of the GE HealthCare <i>MR Service Safety Manual</i> (5452735).</li> <li>• Have successfully completed all relevant GE HealthCare Environmental Health and Safety (EHS) courses (or for non-GE employees, equivalent workplace training courses).</li> <li>• Comply with all site-specific training and workplace safety requirements.</li> </ul> <p>If you have any safety concerns at any time, do not begin work or immediately stop work and move to a safe location. Immediately contact your supervisor or site safety officer for instructions on how to proceed.</p>
---

### About this task

Make sure that the third-party vendor for the scan room has installed the ISC PW frame and ICC SPW frame, and that they are mounted from the equipment room. Refer to architectural site layout drawings for specifications and mounting locations.

**Figure 2-3 Fasteners through penetration panel adapter plate, RF shield, and wall (Standard on the wall configuration)**

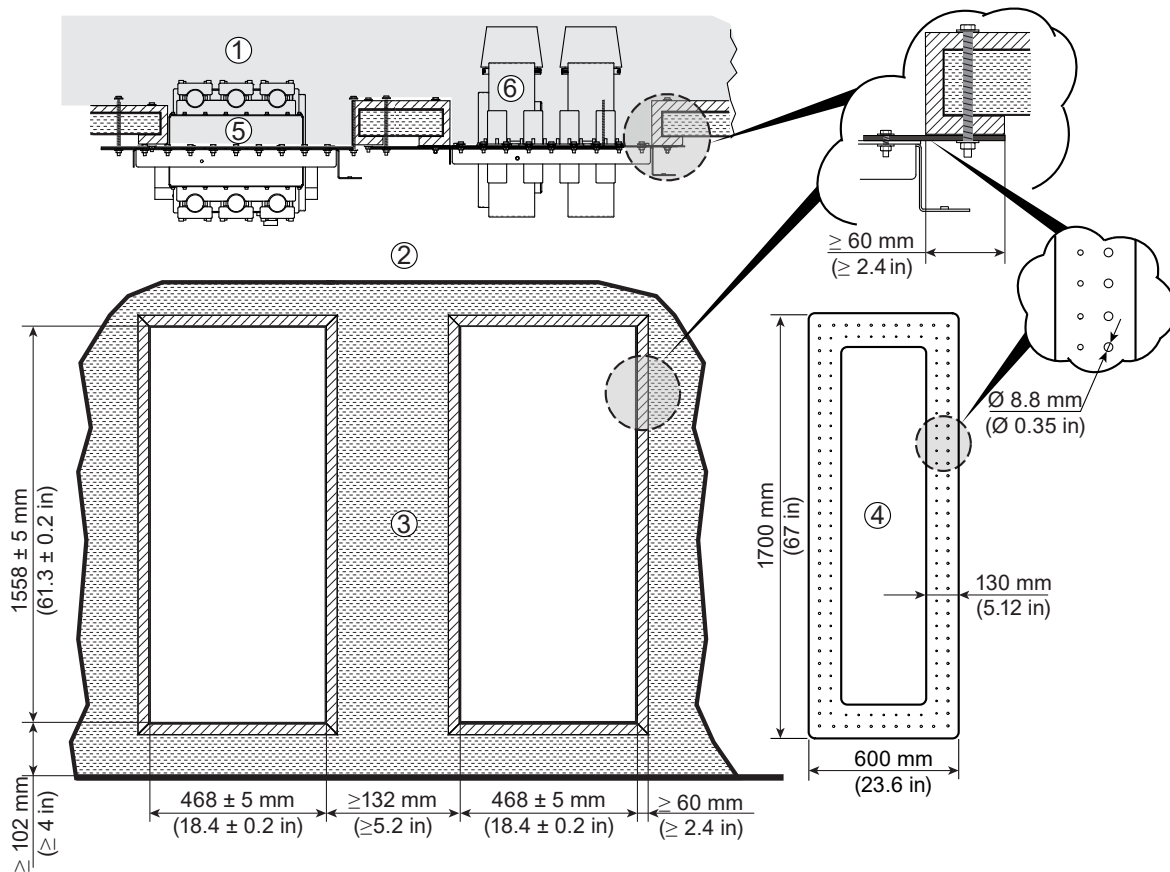

## 2.3 Preparing the Integrated Cooling Cabinet (ICC) or the Platform Integrated Cooling Cabinet (pICC) for the magnet installation

### About this task

Check the ICC unit and complete one of the following:

- [2.3.1 Uncrating and positioning the Integrated Cooling Cabinet \(ICC\) on page 22](#)
- [2.3.2 Uncrating and positioning the Platform Integrated Cooling Cabinet \(pICC\) on page 35](#)

## 2.3.1 Uncrating and positioning the Integrated Cooling Cabinet (ICC)

### Procedure

1. Put the crate in position. Make sure there is a minimum clearance of 1219 mm (4 ft) behind the crate and 4267 mm (14 ft) in front of the crate.

 **WARNING**



**POTENTIAL CRUSH HAZARD**

The crate and ICC are heavy. During crate disassembly, the front panel can fall. During ICC positioning, the ICC can tip. Both situations can cause injury upon impact.

Make sure that two people are present to disassemble the crate and move the ICC.



**NOTE**

Weight of ICC is 560 kg (1,235 lbs).

2. Remove the eight screws from the bottom of the front panel.



**NOTE**

The screws that you need to remove are marked in red on the crate.

3. On the left side panel, remove the six upper screws along the front edge.
4. On the right side panel, remove the six upper screws along the front edge.
5. With an assistant holding the front panel in position, remove the eight screws from the top of the front panel.
6. Remove the front panel and lay it on the floor, front side down, in front of the crate.
7. Remove the screw from the folding subpanel that is located at the bottom of the front panel.

**Figure 2-4 Folding subpanel**

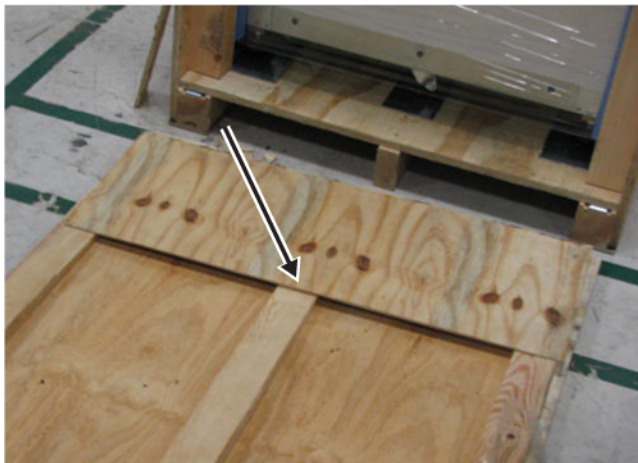

8. Lift the subpanel away from the front panel, extending it from the end of the front panel.

9. Turn the front panel over, making it into a ramp for the cabinet. The subpanel should still extend out from the end of the ramp.

**Figure 2-5 Cabinet ramp**



10. Engage the two hooks on the opposite end of the ramp with the two brackets on the crate base.

**Figure 2-6 Crate hook (left) and ramp hook (right)**



11. Make sure the ramp is secure and flush with the base.

**Figure 2-7 Cabinet ramp and crate base**



12. Remove the six screws from the lower front edge of the left panel to release the left wooden brace that holds the cabinet. Remove and discard the brace.

13. Remove the six screws from the lower front edge of the right panel to release the right wooden brace that holds the cabinet. Remove and discard the brace.
14. Remove the eight screws from the bottom of the left panel.
15. Remove the eight screws from the bottom of the right panel.
16. Remove the eight screws from the bottom of the rear panel.
17. Pull the two webbed handles on the rear of the crate until the crate clears the cabinet and crate base.

**Figure 2-8 Crate webbed handles**

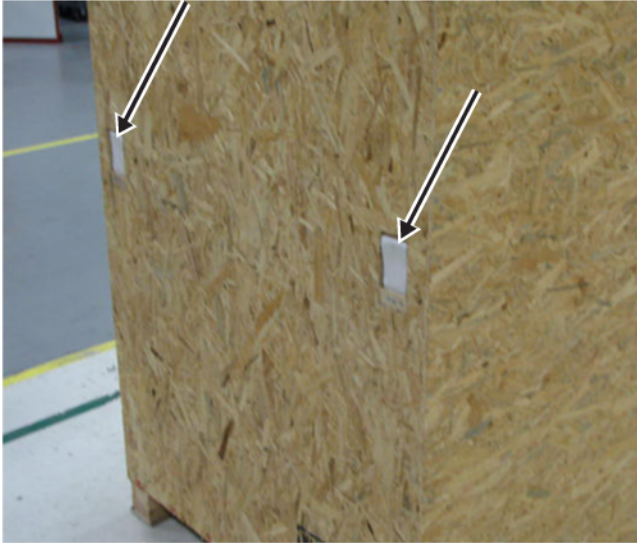

18. With a minimum of two people, roll the cabinet straight down the ramp.
19. Break down and discard the crate.
20. Remove the wrapper, shipping tape, and protective foam from the cabinet.
21. Install three bushings along the bottom of the left side of the cabinet.

**Figure 2-9 Installing the bushings**

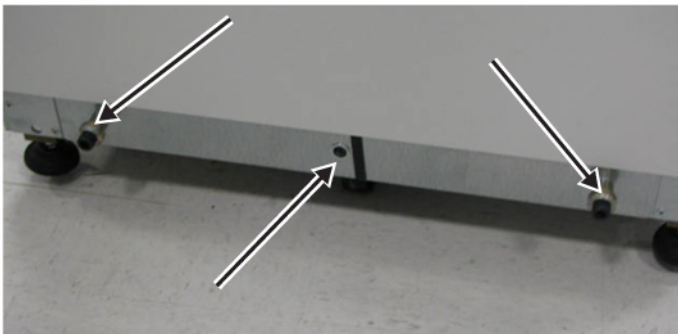

22. Install three bushings along the bottom of the right side of the cabinet.

23. If not already done, remove the two screws with wing nuts from the opposite ends of the dolly to separate the two dolly halves.

**Figure 2-10 Separating the two dolly halves**



24. Put one half of the dolly against the left side of the cabinet, engaging the bushings in the wide openings at the attachment point. Slide the dolly sideways to move the bushings to the thin slots.

**Figure 2-11 Mounting lugs and dolly keyhole slots**



25. Put the other half of the dolly against the right side of the cabinet, engaging the bushing in the wide opening at the attachment point. Slide the dolly sideways to move the bushing to the thin slot.



**NOTE**

Use the dolly to move the cabinet. The wheels on the cabinet are only suitable for moving short distances when the cabinet is near its final install location.

26. Using an adjustable wrench or socket wrench to rotate the jacking screws, raise the dolly until there is pressure or the cabinet just starts to lift.

**Figure 2-12 Adjusting the dolly**

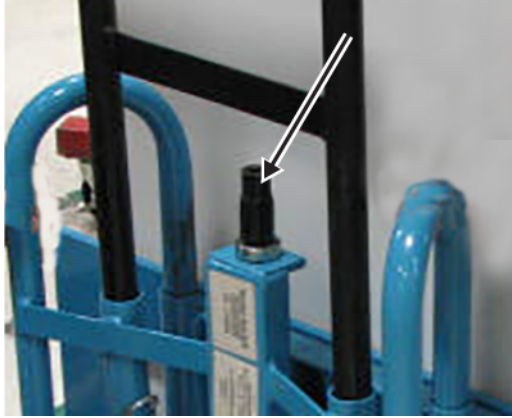

27. Then raise the dolly in 6 mm (0.25 inch) increments on each side until the cabinet is raised 25.40 mm (1.00 inch).
28. Wrap the strap around the cabinet and through the slots on the two dollies. Put the red stripe on the jack strap to face outward (away from the cabinet).

**Figure 2-13 Securing the cabinet on the dolly**



29. Tighten the strap.
30. Use the dolly to roll the cabinet into position in the equipment room until the cabinet is parallel to the wall and close to its final install location.
31. Remove the strap.
32. Rotate the jack screws to lower the cabinet until it rests on the floor.
33. Loosen the bushings.
34. Disengage the dollies from the bushings.
35. Remove the bushings from the cabinet.

36. Make sure the Integrated Cooling Cabinet (ICC) has the following part numbers:

**NOTE**

If any of the part numbers do not match the ones in the list, the ICC is not configured for the Architect or Artist system. If the cabinet part number is incorrect, the correct cabinet must be ordered prior to installation. If a component part number is incorrect, replace the component with the correct component.

- Cabinet: 5599329
- Control Box: 5599333-2
- Gradient Cooling Unit: 5599336-2
- Cabinet Cooling Unit: 5599337-2

37. Move the cabinet into its final install position.

38. If you can get to the adjusters, lower the four adjusters on the ICC so that they reach to the floor.

**NOTE**

At a minimum, the two front adjusters need to be lowered.

39. If the site is a seismic site, attach the ICC side anchor brackets according to the illustration below.

**Figure 2-14 Attaching the ICC side anchor brackets**

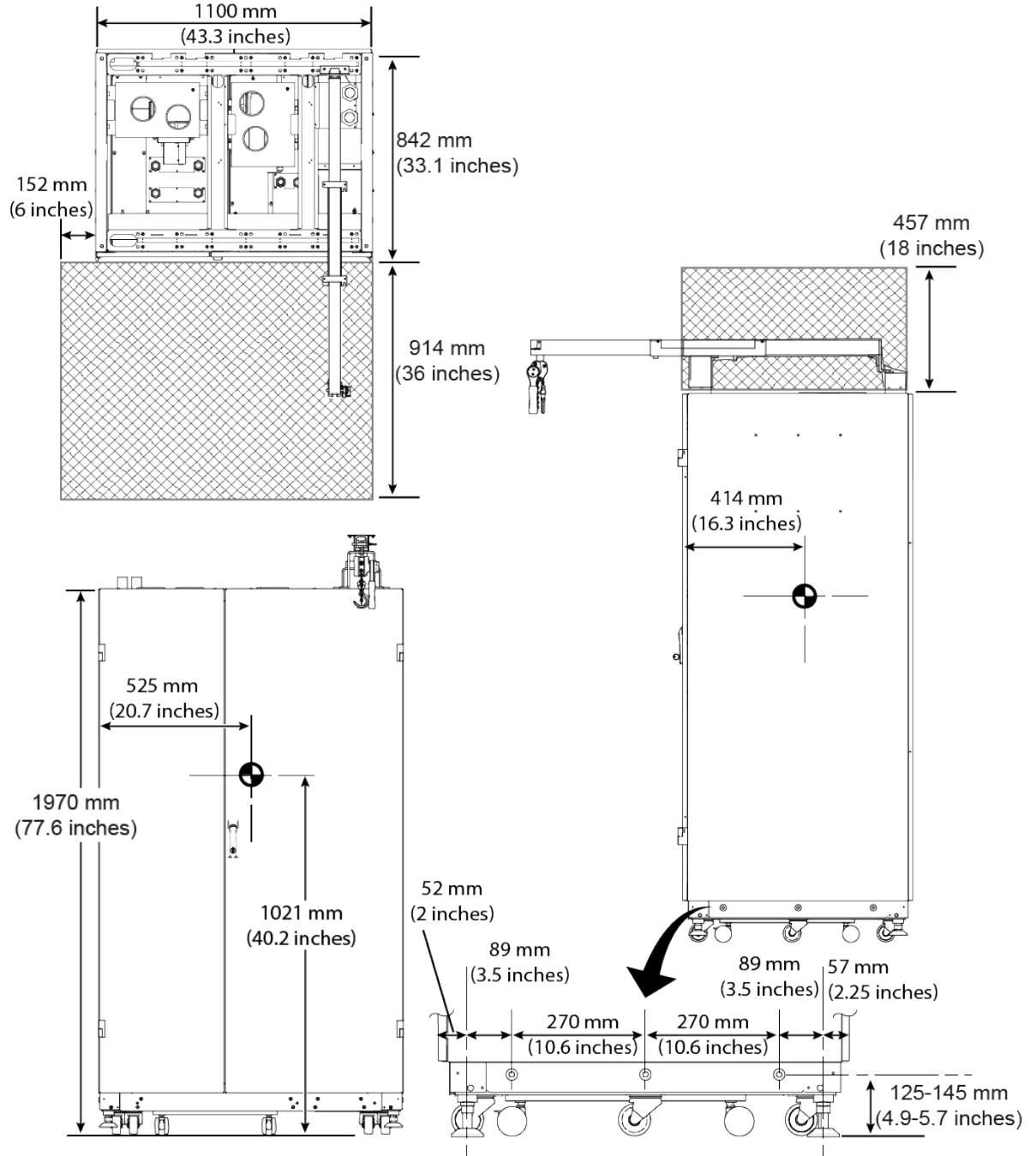

40. Check the level of the cabinet as described in the next task.

## 2.3.1.1 Checking the level of the Integrated Cooling Cabinet (ICC)

### Prerequisites

Tools and test equipment			
Item	Quantity	Part number	Manufacturer
Level	1	-	-

### Procedure

1. Put the level on the top front frame, and measure the level of the X-Z plane. Check that the bubble is centered between the lines.
2. Put the level on the top side frame (left or right), and measure the level of the Y-Z plane. Check that the bubble is centered between the lines.
3. If the cabinet is not leveled, adjust the cabinet using the front adjusters.

**Figure 2-15 Adjusting the cabinet height**

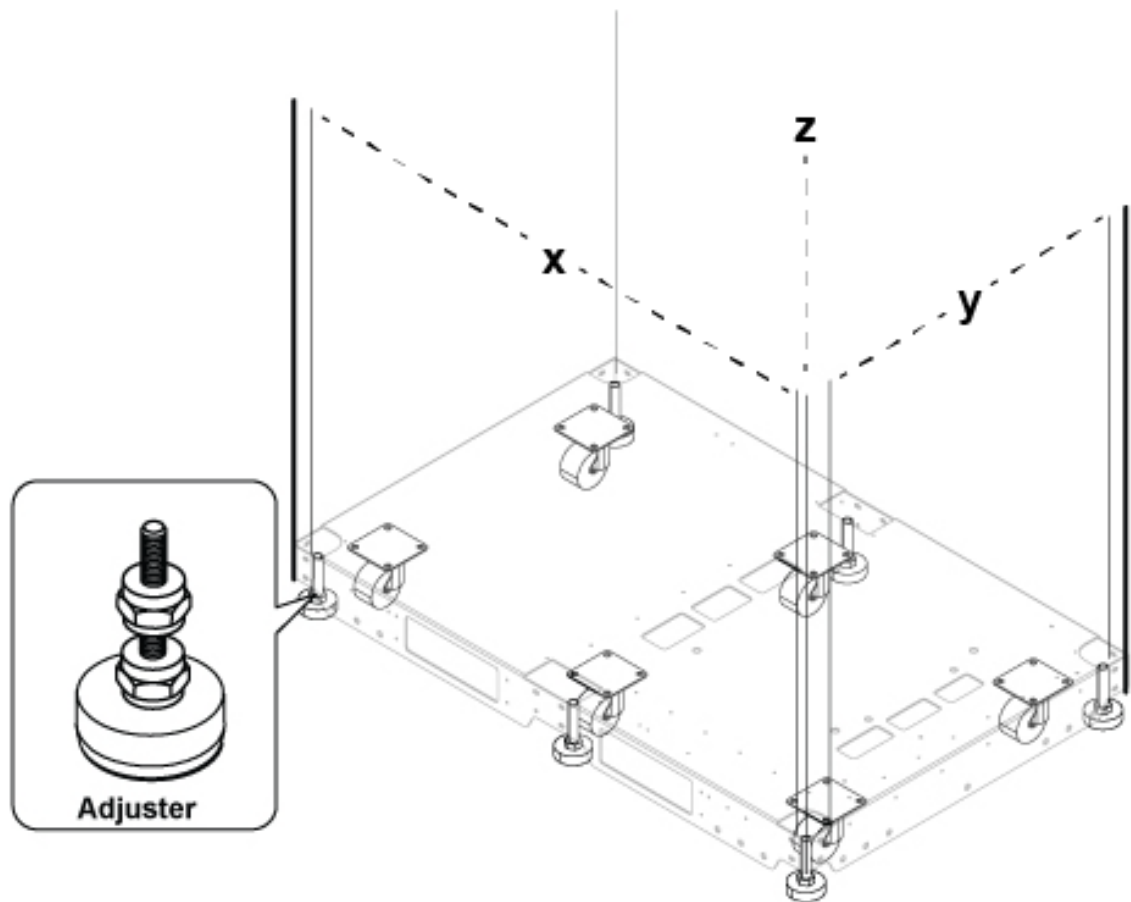

## 2.3.1.2 Connecting the cryocooler hoses and cables (equipment room) [Integrated Cooling Cabinet (ICC)]

### Procedure

1. Connect **Cable Run 623** to **Cable Run 624** using the provided terminal board.

**Figure 2-16 Cable Run connections**

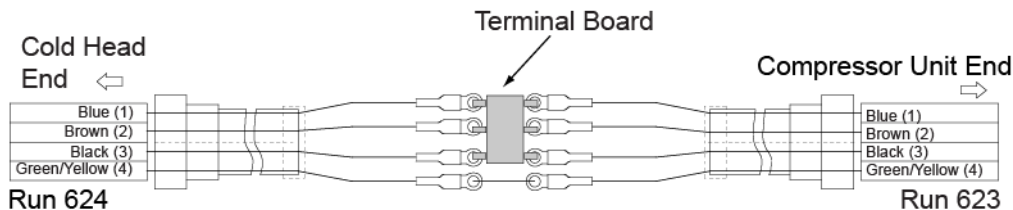

2. Before routing the hoses and cables, do a check of the hose/cable alignment on the tray.

**Figure 2-17 Equipment room cable tray cross section view**

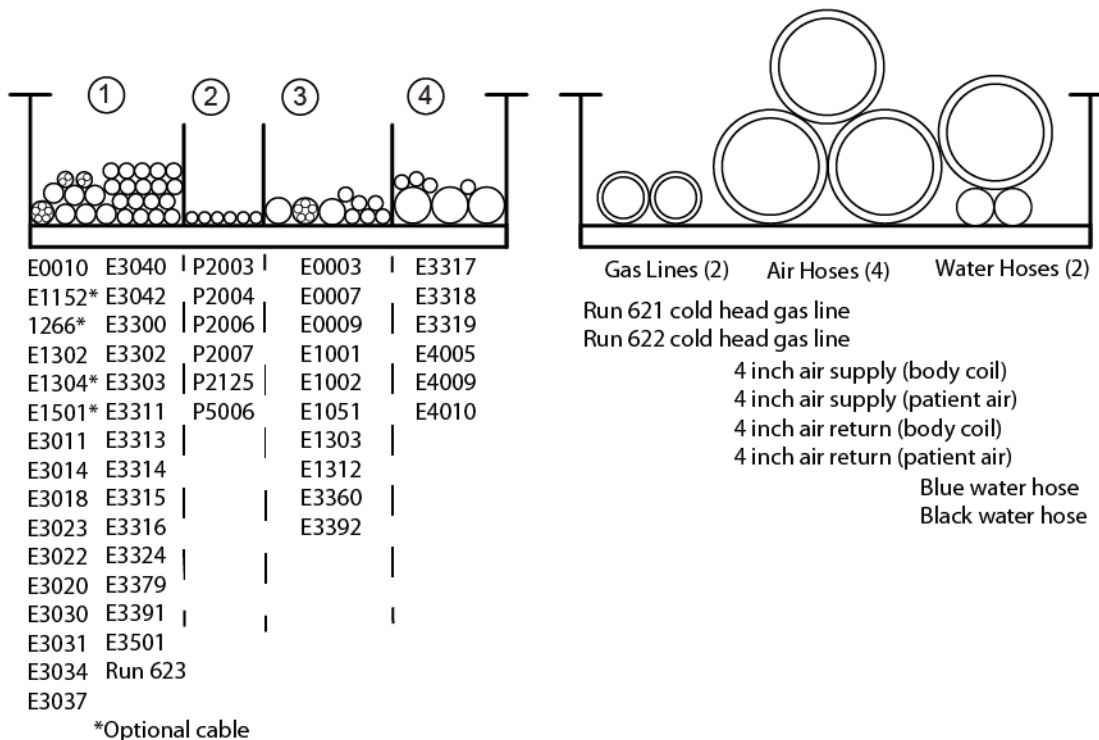

Item	Description
1	300V signal, 300V power, and 300V power/signal
2	Fiber optic
3	≥ 600V coax/RF and AC power
4	Gradient and RF common ground

3. If the facility water hoses are not already connected, have the site connect them to the 1-1/2 inch female NPT fittings on top of the Integrated Cooling Cabinet (ICC).

**Figure 2-18 Connecting the facility water hoses to the ICC**

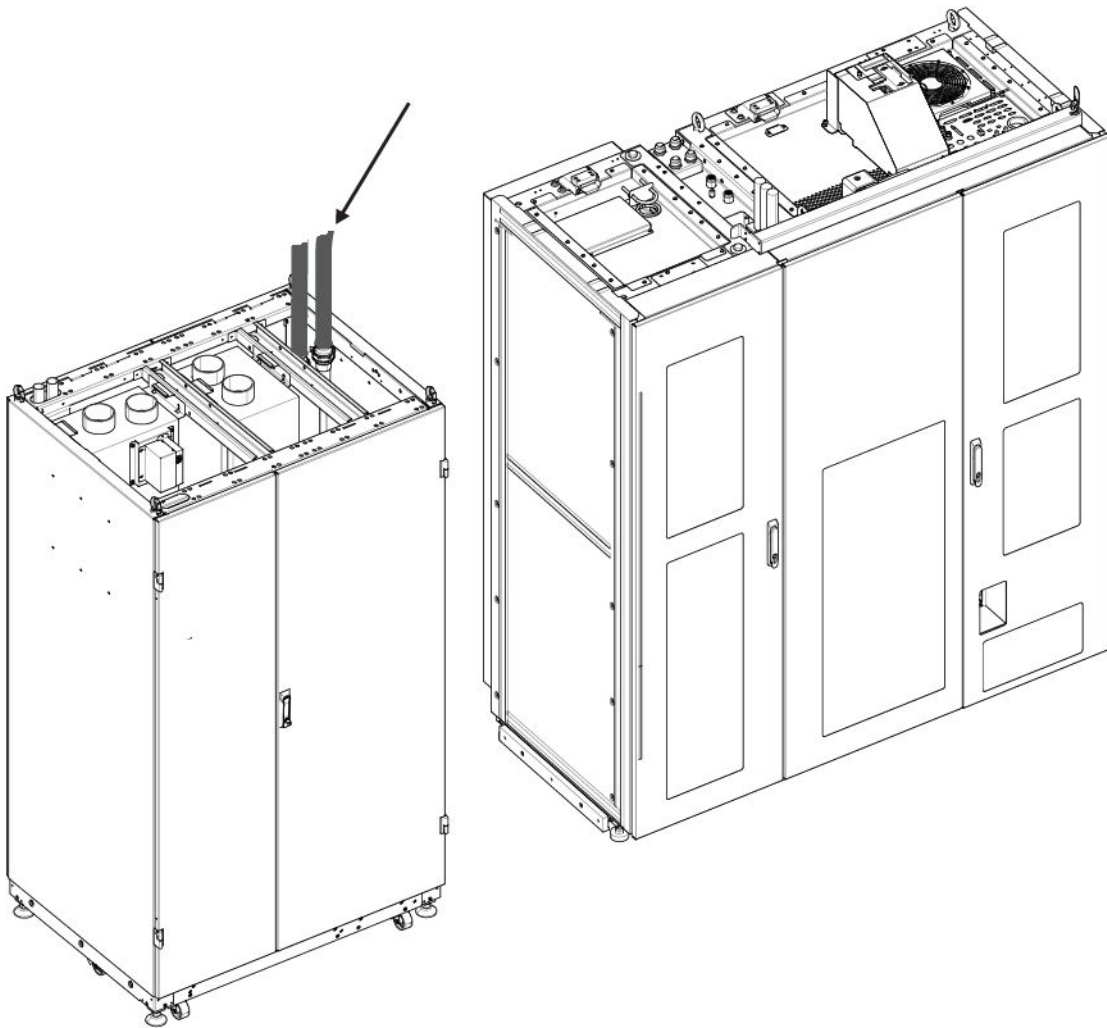

4. Connect two elbow hose nipples and extension (supplied with the ICC) to the F-50 water supply and return ports.

**Figure 2-19 Connecting the water hoses**

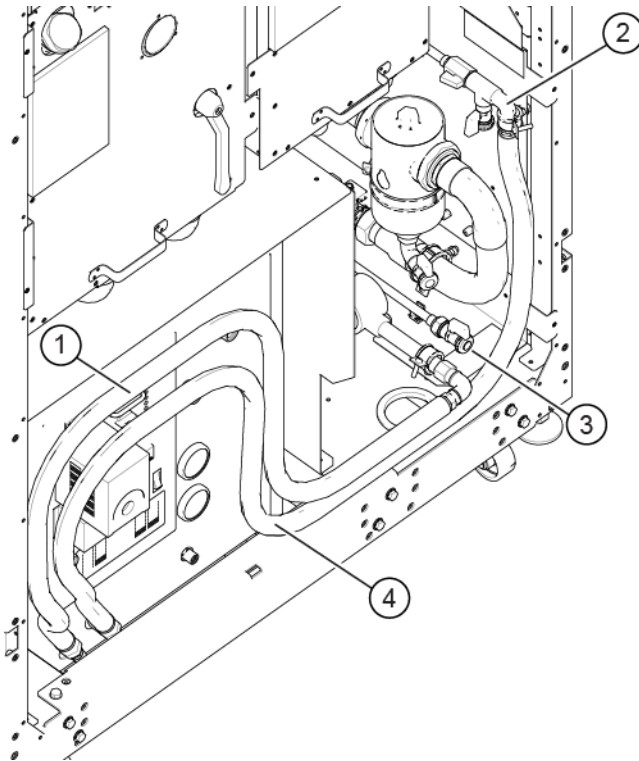

Item	Description
1	Inlet (supply 90-degree elbow and extension)
2	FPU drain line, upper/city water return
3	FPU drain line, bottom/city water supply
4	Outlet (return 90-degree elbow)

5. Connect the water hoses in between the Facility Plumbing Unit (FPU) and the F-50.
  - 5.1. Use the gray hose for the supply line and the yellow hose for the return line.
  - 5.2. Secure the hose connections to the F-50 with a wrench.

6. Rearrange insulation already in place from the ICC vendor to provide maximum coverage.

**Figure 2-20 Arranging the hose insulation**



7. Install the bottom reinforcement bar.

**Figure 2-21 Installing the reinforcement bar**

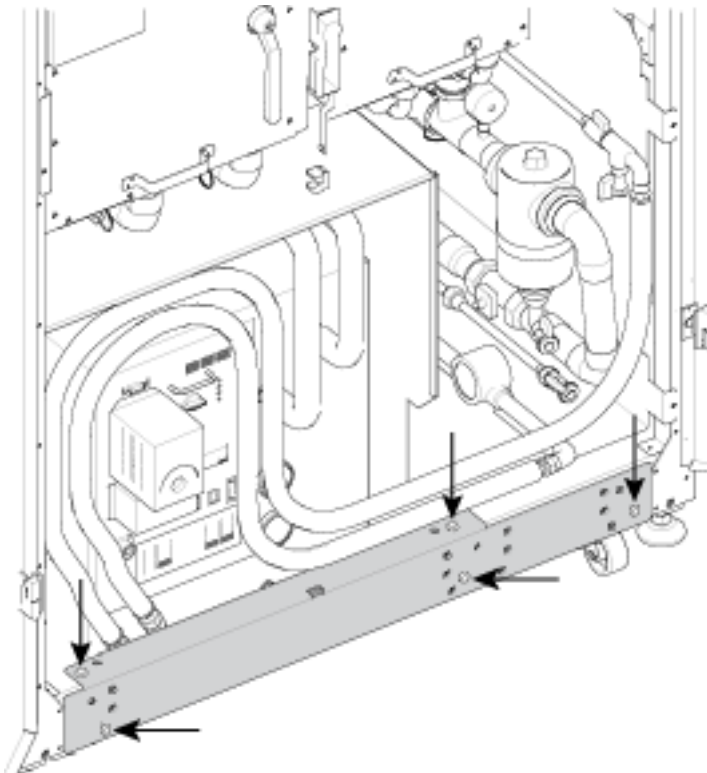

8. Route and connect the following cables:
  - The customer should route the F-50 power cable (Run E0009) from GE **MDP > CB4/C1** to **ICC > F-50 Cryocooler > Power** and connect the cable to the cryocooler using a 90-degree

elbow fitting. Include a service loop in the cable at the cryocooler to allow the cryocooler to be pulled out for servicing.

- Route the sensor cables (Run 833) and connect them to the magnet monitor.
- Connect the cables between the magnet monitor and the ICC SPW.



**NOTE**

The F-50 power is provided by the GE Main Disconnect Panel (MDP) with a 30A breaker. If the customer purchased their own MDP, a 30A breaker or equivalent is required.

**Figure 2-22 Routing the F-50 power cable**

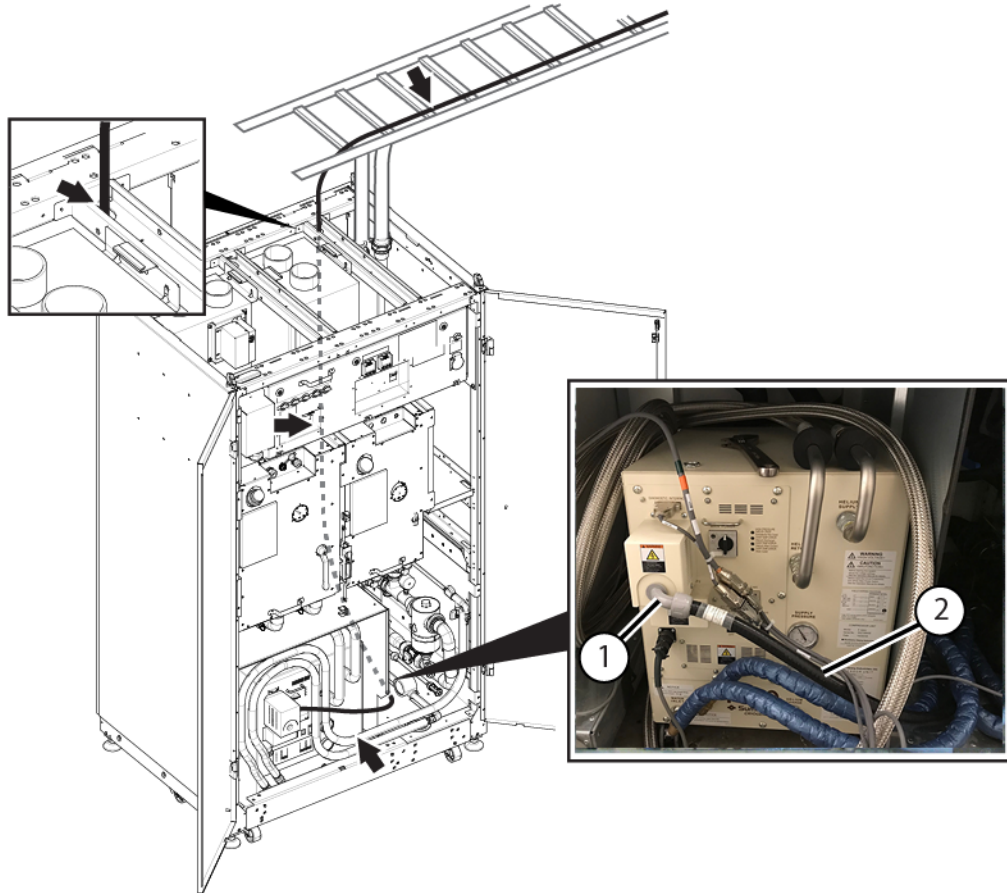

Item	Description
1	90° elbow fitting
2	F-50 power cable

## 2.3.2 Uncrating and positioning the Platform Integrated Cooling Cabinet (pICC)

### Prerequisites

Personnel requirements			
Required persons	Preliminary requirements	Procedure	Finalization
2	-	2 hours	-

Tools and test equipment			
Item	Quantity	Part number	Manufacturer
Pair: Nonferrous Safety Shoes	1	-	-
Pair: Insulated Leather Gloves	1	-	-
Screwdriver (power tool recommended)	1	-	-

Required conditions
The floor under the pICC is leveled per the <i>SIGNA™ Premier Preinstallation Manual (5815067)</i> .
For seismic areas, anchor holes for the pICC have been drilled by a pre-installation vendor. Refer to the <i>SIGNA™ Premier Preinstallation Manual (5815067)</i> for the anchor locations.

**Table 2-5 Safety**

<p>Before working in any GE HealthCare MR suite or doing any GE HealthCare service procedure, you must:</p> <ul style="list-style-type: none"> <li>• Have read and understood all hazard conditions and safety requirements in the latest revision of the <i>GE HealthCare MR Service Safety Manual (5452735)</i>.</li> <li>• Have successfully completed all relevant GE HealthCare Environmental Health and Safety (EHS) courses (or for non-GE employees, equivalent workplace training courses).</li> <li>• Comply with all site-specific training and workplace safety requirements.</li> </ul> <p>If you have any safety concerns at any time, do not begin work or immediately stop work and move to a safe location. Immediately contact your supervisor or site safety officer for instructions on how to proceed.</p>
---

### About this task



#### **WARNING**

#### POTENTIAL CRUSH HAZARD

The crate and pICC are heavy. During pICC positioning, the pICC can tip. This situation can cause injury upon impact.

Make sure that two people disassemble the crate and move the pICC. Prior to removing the shipping brackets, make sure the pICC is resting on its feet and not the wheels to prevent movement of the pICC when attaching the cabinet dolly.

## Procedure

1. Uncrate the disposable pICC packaging, and recycle at the site.



### NOTE

The pICC is secured to the base of the crate using two shipping brackets (on the left and right sides). Prior to removing the shipping brackets, make sure the pICC is resting on its feet and not on the wheels, to prevent movement of the pICC when attaching the cabinet dolly.

**Figure 2-23 pICC packaging**



### NOTE

Make sure the chains and straps are rated for the weight of the pICC, and that they are securely fastened to the eyebolts and the lifting mechanism.

The weight of the pICC:

- Uncrated weight: 425 kg (935 lbs)
- Global crated weight: 486 kg (1071 lbs)

- Remove the shipping bracket mounting hardware and crate base fasteners to release the pICC from the base of the crate as shown below. After these fasteners have been removed, the pICC can be lifted off the base.

**Figure 2-24 Crate base mounting**

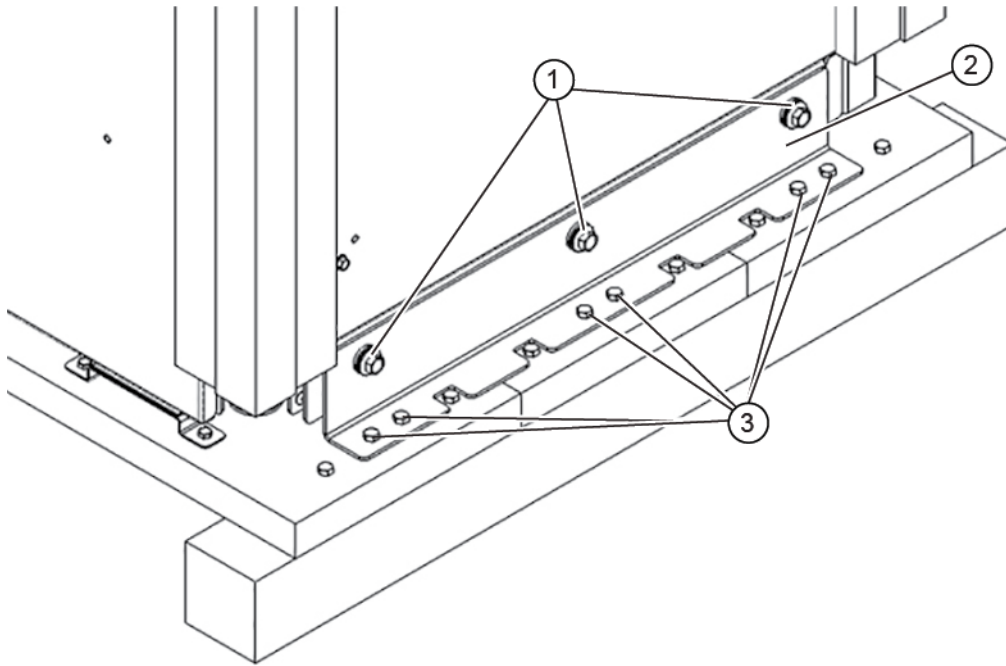

1	Mounting hardware
2	Shipping bracket
3	Base crate fasteners

- Install three bushings along the bottom of the left side of the cabinet.

**Figure 2-25 Installing the bushings**

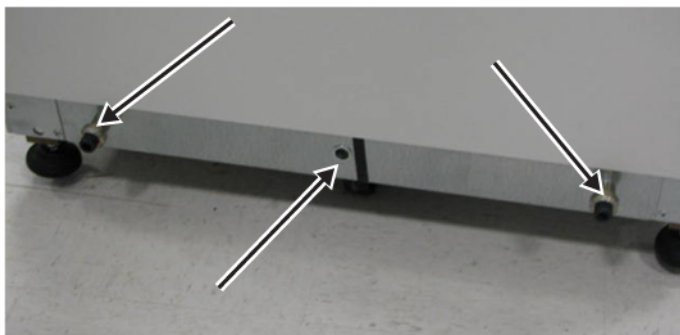

- Install three bushings along the bottom of the right side of the cabinet.

- Maneuver the dolly so that all three bushings slip into the slide lock on the attachment plate.

**Figure 2-26 Bushings and slide lock on attachment plate**

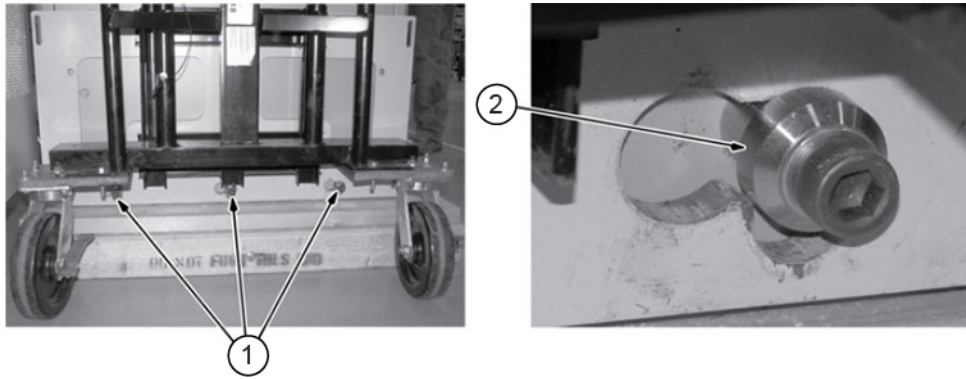

1	Bushings
2	Bushing in slide lock on attachment plate

- Raise the dolly by turning the jack screw clockwise to lock the dolly into position.

**Figure 2-27 Securing pICC to dolly**

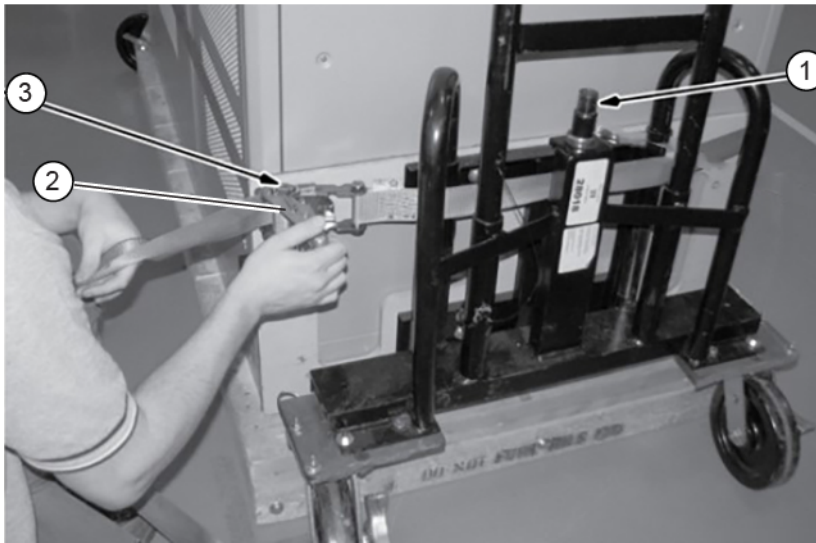

1	Jack screw
2	Clamp
3	Strap

7. Fasten the pICC to the dollies with the strap. Put the jack strap through the slot of the attachment plate, with the red stripe facing out (away from the cabinet). Make sure the clamp is on a flat surface of the dolly.

**Figure 2-28 Jack strap**



8. Using an adjustable wrench or socket wrench to rotate the jacking screws, raise the dolly until there is pressure or the cabinet just starts to lift.

**Figure 2-29 Adjusting the dolly**



9. Lift the pICC off the pallet by turning the jack screw clockwise until the cabinet is raised.
10. Alternate raising each dolly in 6 mm (0.25 inch) increments until the cabinet is raised above the pallet.
11. Slide the pallet out from under the cabinet.
12. Alternate lowering each side of the cabinet by turning the jack screw counterclockwise until the cabinet is 25.40 mm (1.00 inch) above the floor.
13. Move the ICC on the dolly into the equipment room.

14. Move the cabinet into its final install position using the four swivel casters.



**NOTE**

The pICC can also be lifted vertically using the eyebolts on the lid. Make sure the chains or straps are rated for the weight of the pICC, and that they are securely fastened to the eyebolts and the lifting mechanism.

**Figure 2-30 Lifting eyebolts**

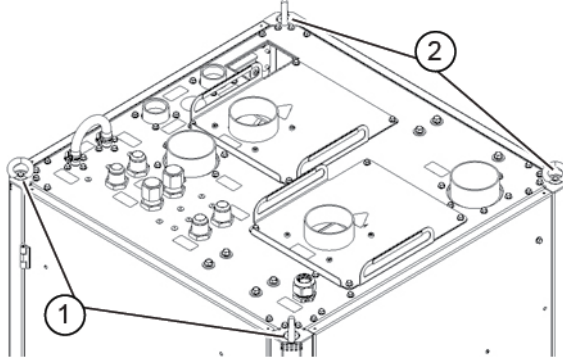

1	Front eyebolts
2	Rear eyebolts

**Figure 2-31 Platform Integrated Cooling Cabinet (pICC)**

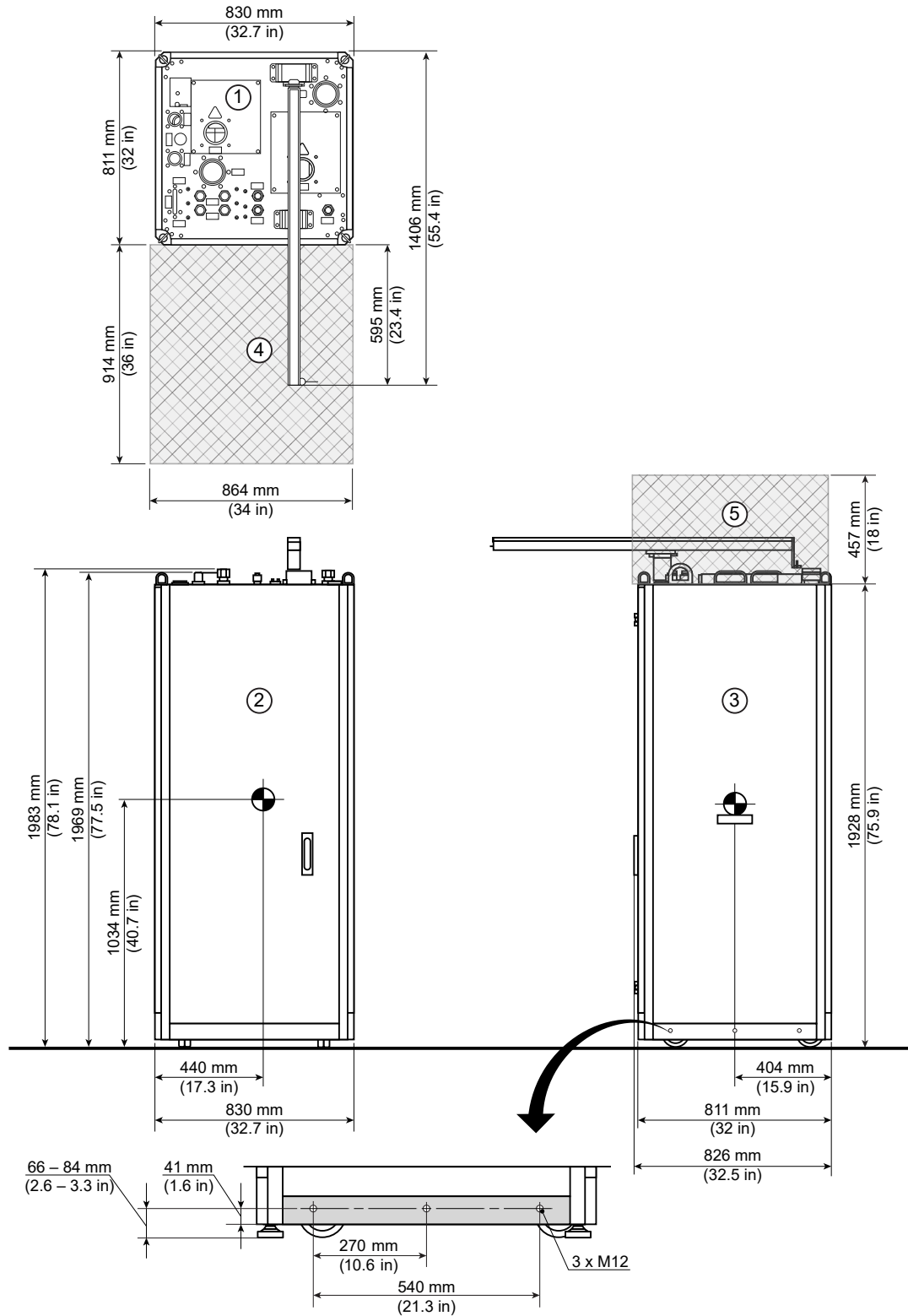

1	Top view
2	Front view
3	Side view

4	Service area
5	Air flow and cables

15.

**NOTICE**



**INSTALL BRACKETS FOR SEISMIC LOCATIONS**

You must install brackets to secure the pICC to the floor using the three M12 threads. If the site is a seismic site, attach the pICC side anchor brackets as shown below. The pICC allows for the installation of seismic brackets onto the left, right, and rear sides of the pICC. At minimum, seismic brackets must be installed on the left and right side of the pICC.



**NOTE**

The minimum full thread depth of the 3X M12 threads is 12.5 mm (.49 inches); the minimum clearance depth is 50.8 mm (2.00 inches).

**Figure 2-32 Attaching the pICC side anchor brackets**

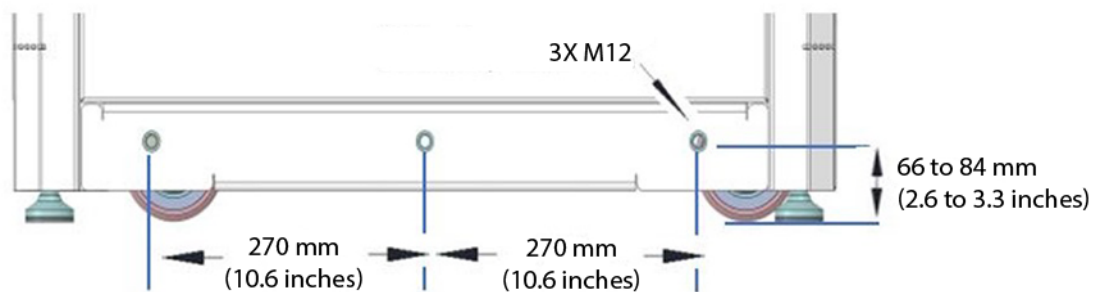

- 15.1. Align the seismic bracket with the mounting nuts on the desired side of the pICC.
  - 15.2. Install the seismic bracket to the pICC using the hardware supplied with the shipping bracket.
  - 15.3. Install the seismic bracket to the ground using the hardware procured and installed locally per site architectural drawings.
  - 15.4. Repeat steps for the other sides.
16. Check the level of the cabinet. See [2.3.2.1 Checking the level of the Platform Integrated Cooling Cabinet \(pICC\) on page 42](#).

### 2.3.2.1 Checking the level of the Platform Integrated Cooling Cabinet (pICC)

**Prerequisites**

Tools and test equipment			
Item	Quantity	Part number	Manufacturer
Level	1	-	-

**WARNING**



**TIPPING HAZARD**

If the incline is greater than 15 degrees, the pICC can tip and fall causing injury upon impact.

Use the limiting hex nut to prevent the feet from extending beyond 30 mm off the ground. If the cabinet must be lifted to the maximum height, ensure the incline is less than 15 degrees.

**About this task**

The pICC has four leveling feet that are used to level the pICC. Lower the four leveling feet on the pICC so they reach the ground.

**Procedure**

1. Access the pICC through the front door.
2. Locate the four threaded rods in each corner.

**Figure 2-33 Threaded rods on pICC**

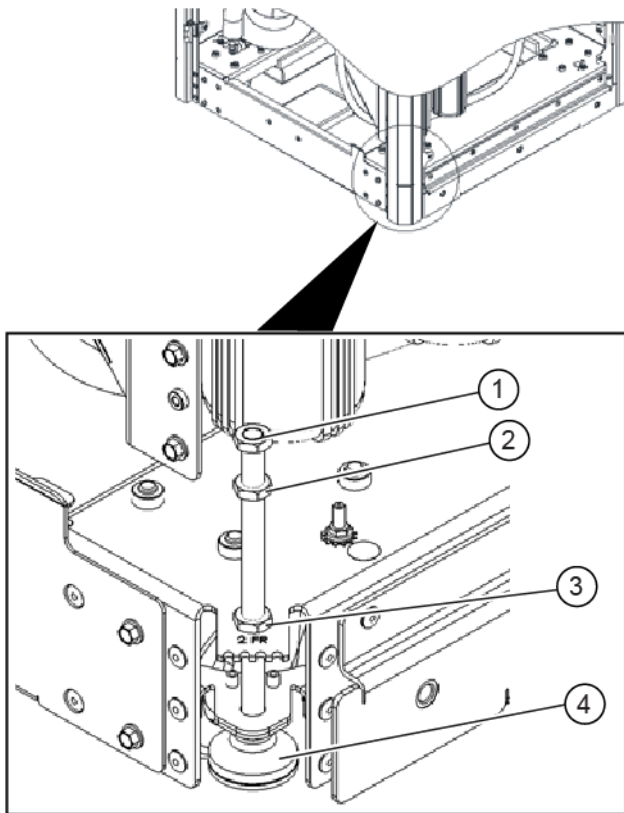

1	Hex nut driver
2	Limiting nut
3	Locking hex nut
4	Leveling foot

3. Using a 19 mm wrench, turn the locking hex nut counterclockwise to free the threaded rod. Repeat on all required rods as necessary.
4. Using a 19 mm wrench, gradually turn the hex nut driver clockwise on each threaded rod, alternating between rods and turning no more than two full rotations for each rod until the pICC is leveled. The locking hex nut may need to be further recessed up the threaded rod. Repeat on all required rods as necessary.

The locking hex nut might need to be recessed up the threaded rod for all of the required rods.

## 2.3.2.2 Connecting the cryocooler hoses and cables (equipment room) [Platform Integrated Cooling Cabinet (pICC)]

### About this task



#### **WARNING**

##### COOLANT LEAKAGE HAZARD

This procedure involves a risk of coolant leakage that could cause property damage, injury and/or death. All plumbing connections should only be completed by properly trained and certified technicians wearing proper protective gear and using the proper tools.

Make sure external plumbing connections have been closed/turned off prior to installing or uninstalling plumbing connections. Complete all plumbing connection installation procedures prior to opening/turning on external plumbing connections. Always make sure that all plumbing connections are free of leaks after installation to prevent property damage or hazardous slip and fall conditions that may lead to injury or death.



#### **WARNING**

##### SUPPLY PRESSURE HAZARD

The supply pressure for the facility side circuit must not exceed 6 bar.

#### **NOTICE**

##### USE THE CORRECT INSTALLATION INSTRUCTIONS

Consult the cryogen compressor's installation manual for the correct installation procedures. Make sure the cooling water supply and return labels are correct prior to installation.

**Procedure**

1. Connect **Cable Run 623** to **Cable Run 624** using the provided terminal board.

**Figure 2-34 Cable Run connections**

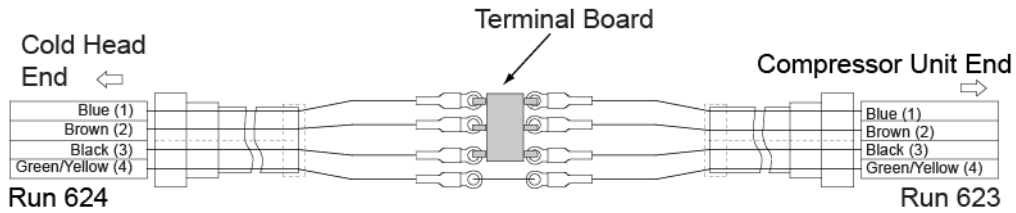

2. Before routing the hoses and cables, do a check of the hose/cable alignment on the tray.

**Figure 2-35 Equipment room cable tray cross section view**

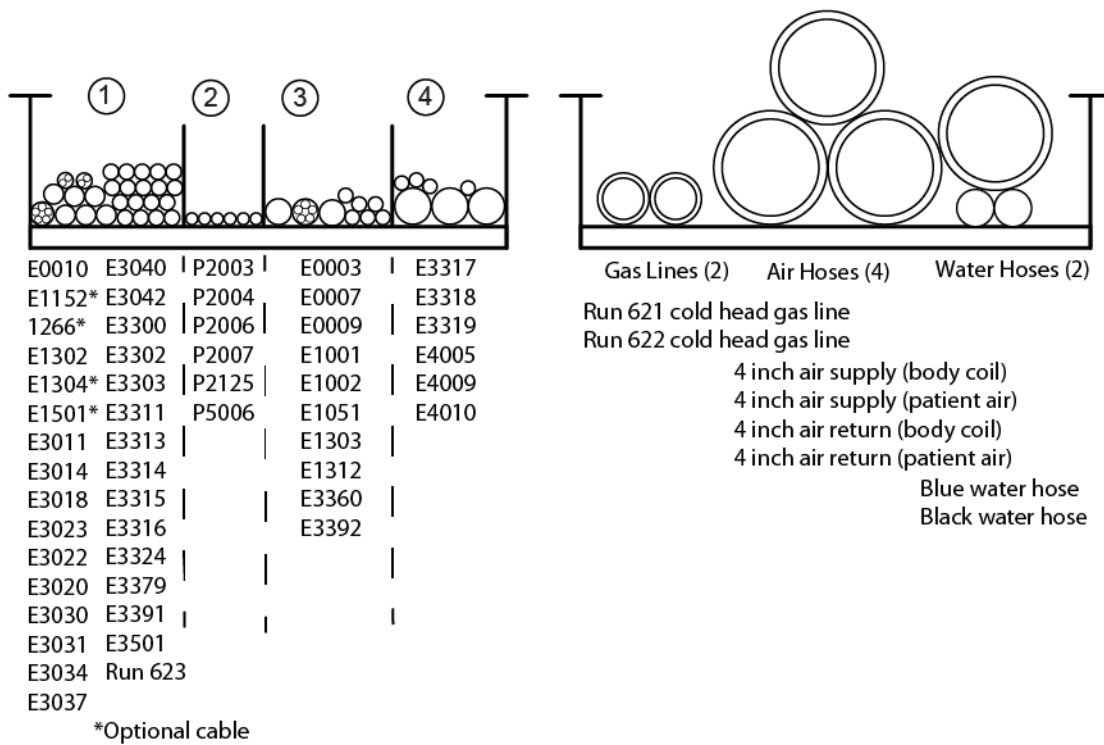

Item	Description
1	300V signal, 300V power, and 300V power/signal
2	Fiber optic
3	≥ 600V coax/RF and AC power
4	Gradient and RF common ground

3. If the facility water hoses are not already connected, have the site connect them to the 1-1/2 inch female NPT fittings on top of the pICC.

- Connect the facility supply (typically chiller) to the pICC port labeled FAC PRIM SPY on the lid using PTFE (Teflon) tape. Wrap the PTFE (Teflon) tape, one-and-a-half wraps around the male portion of the thread. Start two threads up from the end of the male portion of the fitting.

**Figure 2-36 pICC lid connection diagram**

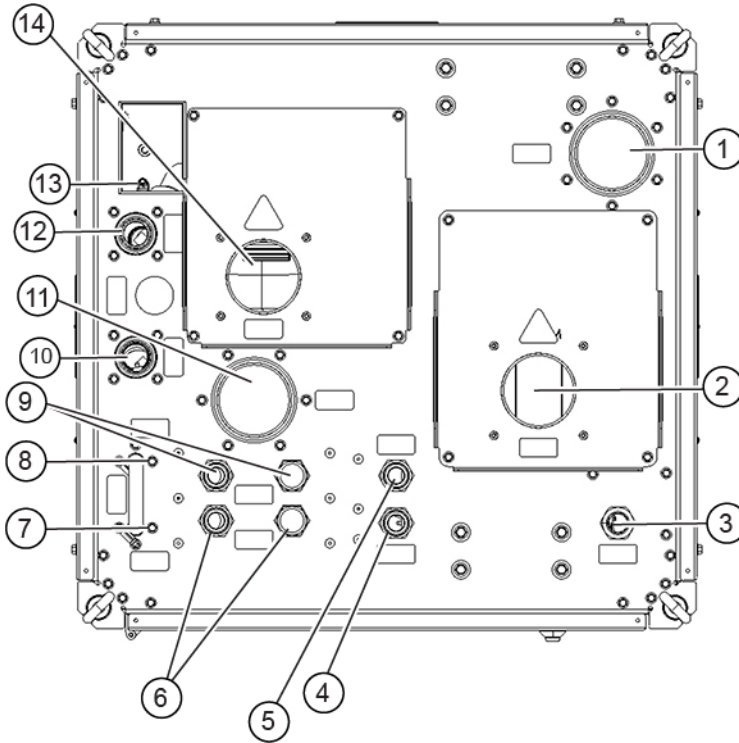

1	PAT AIR RTN	4 inch hose duct	PB air return from MR to pICC
2	BC AIR SPY	4 inch hose duct	BB air supply from pICC to MR
3	J1	Cord grip	Incoming power cable to pICC
4	GC SEC RTN	1 inch 37° JIC male (size 16)	GCU coolant return from MR to pICC
5	GC SEC SPY	1 inch 37° JIC male (size 16)	GCU coolant supply from pICC to MR
6	ISC SEC RTN	1 inch 37° JIC male (size 16)	CCU coolant return from ISC to pICC
7	CW SPY	½ inch hose bead	Emergency backup coolant supply from pICC CRY circuit
8	CW RTN	½ inch hose bead	Emergency backup coolant return to pICC CRY circuit
9	ISC SEC SPY	1 inch 37° JIC male (size 16)	CCU coolant supply from pICC to ISC
10	FAC PRIM SPY	1 ½ inch FPT	FPU coolant supply from chiller to pICC

11	BC AIR RTN	4 inch hose duct	BB air return from MR to pICC
12	FAC PRIM RTN	1 ½ inch FPT	FPU coolant return from pICC to chiller
13	N/A	Opening	Helium hose connections to and from cryogen compressor, serial cable (44-pin D-sub) connection to electrical enclosure, PHPS2 signal cable to PB
14	PAT AIR SPY	4 inch hose duct	PB air supply from pICC to MR

5. Connect the facility return (typically chiller) to the pICC port labeled FAC PRIMRTN on the lid using PTFE (Teflon) tape.
6. Install the NPT plumbing connections per ASME B1.20.3 standards.

**Figure 2-37 pICC FPU valves for adjustment**

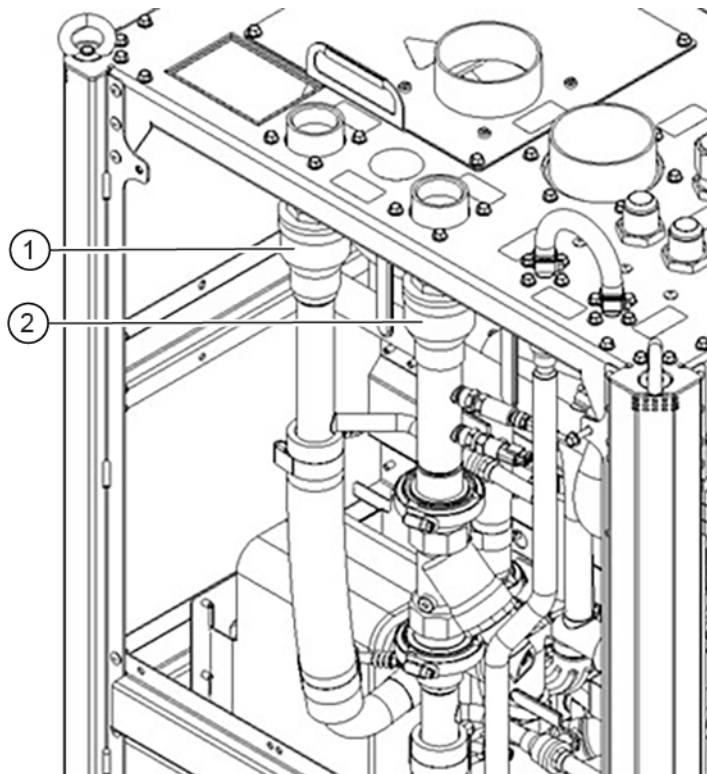

1	Facility return valve
2	Facility supply valve

7. Configure the valves in the pICC to enable coolant flow to the FPU circuit:
  - 7.1. Locate the FPU supply and return valves in the pICC.
  - 7.2. Open both valves with the handle parallel to the direction of the flow.
8. The cryogen compressor fittings kit is supplied within the ship loose box and contains the following: 2 stainless steel 90° ½ inch (size -8) JIC male adapter to 3/8 inch BSPT male elbow

adapters, and 1 stainless steel 3/8 inch BSPT male-to-female bushing. To install the cryogen compressor cooling connections, complete the following:

- 8.1. Access the pICC through the front door.
- 8.2. Locate the CRY cooling hoses and clip cable ties on each hose to unravel them.

**Figure 2-38 Cryogen compressor cooling hoses**

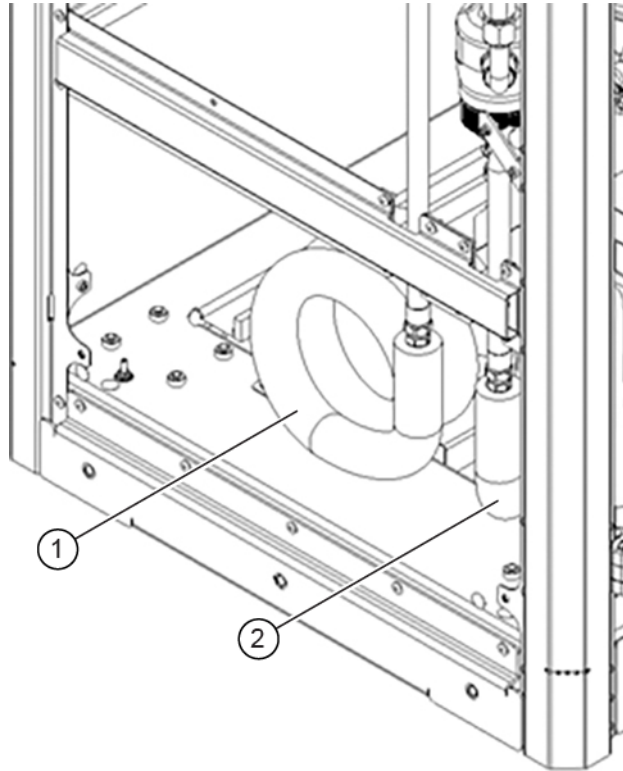

1	CRY cooling return hose
2	CRY cooling supply hose

- 8.3. Use the gray hose for the supply line and the yellow hose for the return line.
- 8.4. The hoses are connected from the factory by a male-to-male adapter (jumper connection). Use a 7/8 inch wrench (for the JIC 37° hose swivel connectors) and a 13/16 inch wrench (for

the male-to-male adapter) to disconnect the hoses from each other and the adapter, and discard the male-to-male adapter.

**Figure 2-39 Cryogen compressor cooling jumper connection removal**

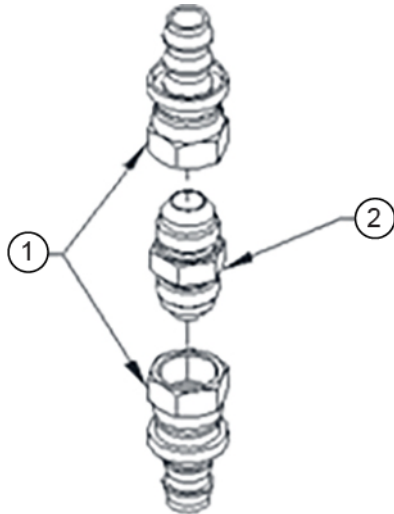

1	JIC 37° swivel fittings
2	Male-to-male adapter

- 8.5. Use a 19 mm wrench to install an elbow at the cooling return port on the cryogen compressor and orient the fitting as shown below. Install the CRY cooling supply hose (labeled **CRY PRIM SPY**) to the other end of the elbow.

**Figure 2-40 Cryogen compressor cooling plumbing orientation**

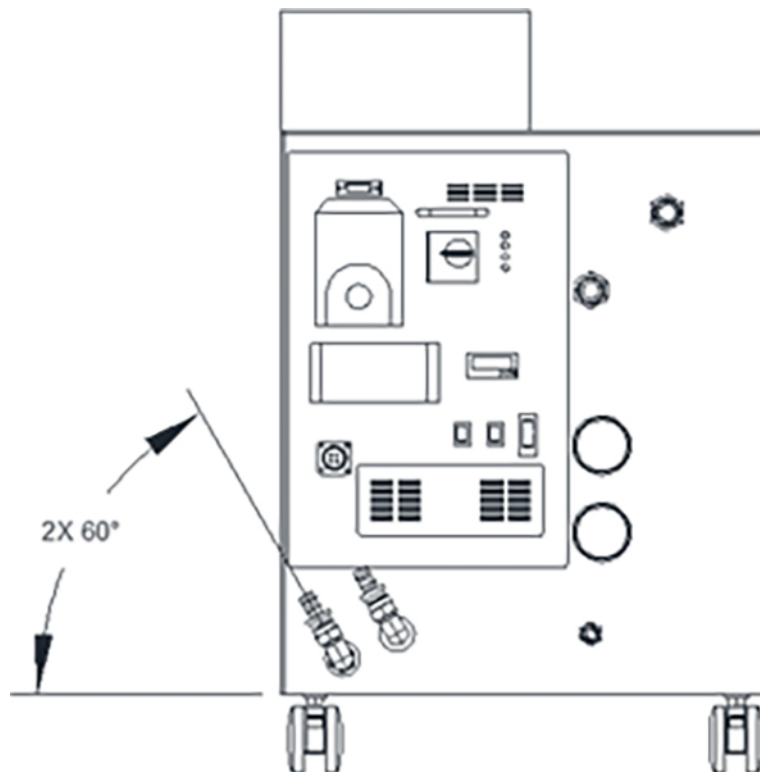

- 8.6. Use a 7/8 inch wrench to install the bushing at the cooling supply port on the cryogen compressor. Install an elbow on the other end of the bushing and orient the fitting as indicated in [Figure 2-40 Cryogen compressor cooling plumbing orientation on page 49](#). Install the CRY cooling return hose (labeled **CRY PRIM RTN**) to the other end of the elbow.
- 8.7. Configure the valves in the pICC as follows to enable coolant flow to the cryogen compressor:
  - 8.7.1. Locate the CRY supply and return valves. Open both valves (handle parallel to direction of flow).
  - 8.7.2. Locate the CW supply and return valves. Make sure both valves are closed (handle perpendicular to direction of flow).
9. To install the cryogen compressor in the pICC, complete the following:
  - 9.1. Access the pICC through the front door.
  - 9.2. Disconnect the auxiliary tank return quick connect hose.
  - 9.3. Uninstall the front gusset:
    - 9.3.1. Use a 10 mm wrench to unfasten the two M6 front gusset bolts A.
    - 9.3.2. Use a 10 mm wrench to unfasten the two M6 front gusset bolts B.
    - 9.3.3. Use a 10 mm wrench to unfasten the four M6 front gusset bolts C.
    - 9.3.4. Remove the front gusset.
  - 9.4. Uninstall the front brace:
    - 9.4.1. Use a 10 mm wrench to unfasten the four M6 front brace bolts.
    - 9.4.2. Remove the front brace.
  - 9.5. Remove the ship loose box and ship loose bracket, or proceed to the next step if these have previously been removed.
  - 9.6. Maneuver the cryogen compressor into the pICC opening. The front of the cryogen compressor should face the front of the pICC. The cryogen compressor should contact foam strips in the pICC at each of its three edges (left, right and rear).

9.7. Reinstall the front brace and its bolts.

The lower door stop of the brace should face upwards. See [Figure 2-41 Cryogen compressor installation \(front view\)](#) on page 51.

**Figure 2-41 Cryogen compressor installation (front view)**

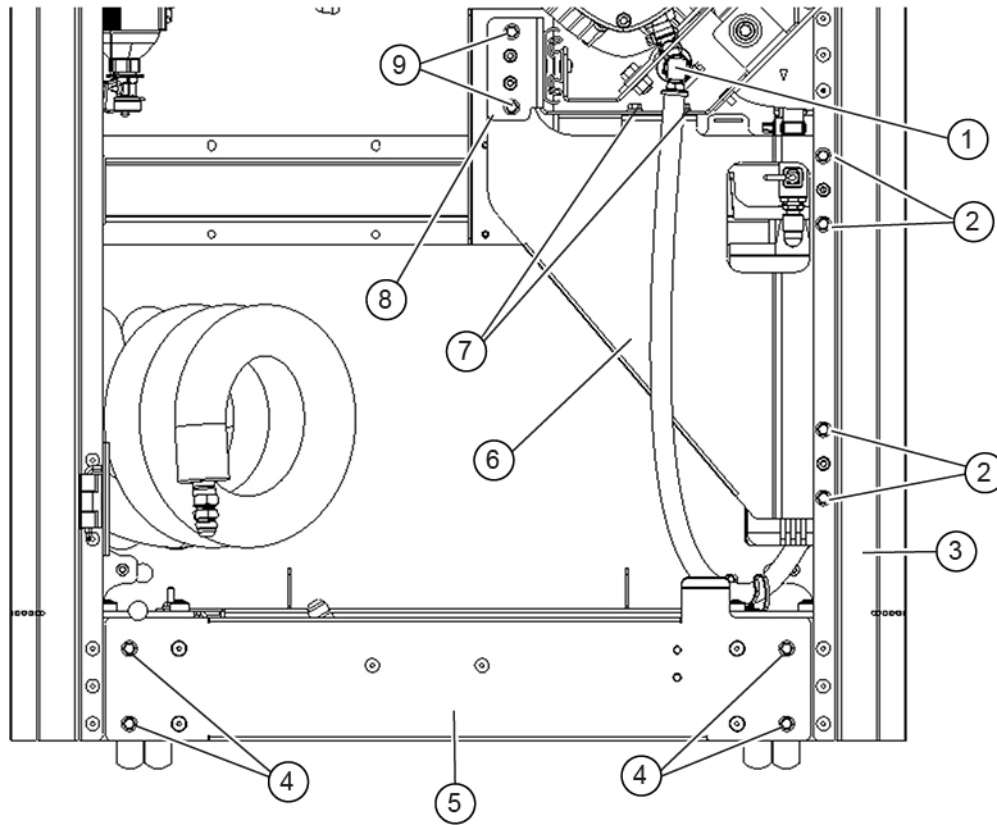

1	Auxiliary tank return quick connect
2	Front gusset bolts C
3	Front right corner
4	Front brace bolts
5	Front brace
6	Front gusset
7	Front gusset bolts A
8	CCU pump slide
9	Front gusset bolts B

9.8. Reinstall the front gusset and its bolts to the CCU pump slide base and front right corner.



**NOTE**

The front gusset fits behind the CCU pump slide base and front right corner.

**Figure 2-42 Positioning studs for front gusset**

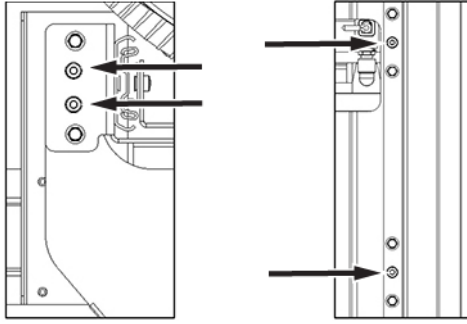

- 9.8.1. Align the front gusset with the positioning studs shown above.
- 9.8.2. Use a 10 mm wrench to install the two M6 front gusset bolts B.
- 9.8.3. Use a 10 mm wrench to install the four M6 front gusset bolts C.
- 9.8.4. Use a 10 mm wrench to install the two M6 front gusset bolts A.
- 9.9. Reinstall the auxiliary tank return quick connect hose to the CCU pump drain port. See [Figure 2-41 Cryogen compressor installation \(front view\) on page 51](#).

## Chapter 3 Completing the installation

### 3.1 Making sure the pre-magnet delivery installation is complete

#### About this task

The following steps need to be reviewed and completed by a GE HealthCare Field Engineer, especially if the system was installed by non-GE HealthCare personnel.

#### Procedure

1. Make sure all steps in the flowchart are complete.
2. Resolve any shipment shortages.
3. Resolve any omissions made by the mechanical contractors.

### 3.2 Completing the GE HealthCare Field Engineer responsibilities

#### Procedure

1. Record and enter applicable data into applicable site configuration files and records.
2. Complete product locator information for all installed serialized components, new or updated, using one of the following methods:
  - **(U.S. Only)** FE Site Verification website
  - Process and return product locator installation cards for all serialized components to:  
**Product Locator File, P.O. Box 414, W-523, Milwaukee, WI 53201-0414**



#### NOTE

Failure to fill out and return product locator cards may result in failure of your site to receive future FMIs.

3. Store the delivered site's set of service tools and spare kit in the service cabinet at the site.
4. Set up and organize a reference cabinet for the service manuals. Leave all service manuals on-site.
5. Locate any Material Safety Data Sheets (MSDS). They must be retained on-site. Inform the customer that material with MSDS was brought on-site, as the customer should know/decide where on-site the MSDS should be retained.
6. Make sure that the entire site is clean from any install debris before handing it over to the customer for clinical scanning. Also inform customer to follow the instructions given in the Operator Manual for cleaning and disinfection prior to starting the clinical scanning.

Page intentionally left blank

## Revision History

Revision	Date	Description
4	April 2024	<ul style="list-style-type: none"> <li>• Routed in MyWorkShop as DOC2079199 Revision 5.</li> <li>• In section 1.2.2, Equipment Room: <ul style="list-style-type: none"> <li>◦ In list item 1, the MDP supply statement was updated.</li> <li>◦ In list item 3, clarification was added about the inclusion of pICC.</li> </ul> </li> <li>• In section 1.2.3 Control Room, list item 3 was updated to include <i>Physiological Acquisition Transceiver (PAT) Charging Station</i>.</li> <li>• In section 1.2.5 System Overview, the Note was updated to include <i>PAT Charging Station</i>.</li> <li>• In section 1.4, Pre-magnet delivery system installation workflow, <i>Figure 1-3 Site installations required prior to system mechanical installation</i> was updated to include part number 5881576-8EN.</li> <li>• In section 2.1, Installing the Main Disconnect Panel (MDP), a Note was added after <i>Figure 2-1 Main Disconnect Panel (MDP)</i>.</li> <li>• In section 2.3 Preparing the Integrated Cooling Cabinet (ICC) or the Platform Integrated Cooling Cabinet (pICC) for the magnet installation, added step 36.</li> <li>• In section 2.3.2, Uncrating and positioning the Platform Integrated Cooling Cabinet (pICC): <ul style="list-style-type: none"> <li>◦ Step 7 was updated.</li> <li>◦ <i>Figure 2-31 Platform Integrated Cooling Cabinet (pICC)</i> was improved.</li> </ul> </li> <li>• In section 2.3.2.2 Connecting the cryocooler hoses and cables (equipment room) [Platform Integrated Cooling Cabinet (pICC)], added substep 8.3.</li> <li>• In section 3.2 Completing the GE HealthCare Field Engineer responsibilities, added step 6.</li> </ul>

Revision	Date	Description
3	April 2022	<ul style="list-style-type: none"> <li>• Routed in MyWorkShop as DOC2079199 Revision 4.</li> <li>• In section 1.1 Getting started, updated R4390JA to R43900JE.</li> <li>• In section 2.3 Preparing the Integrated Cooling Cabinet (ICC) for magnet installation: <ul style="list-style-type: none"> <li>◦ Updated the title and short description to include Platform Integrated Cooling Cabinet (pICC).</li> <li>◦ Added About this task section and cross-references for the existing Uncrating the ICC topic and added cross-reference to the new Uncrating the pICC topic.</li> </ul> </li> <li>• Created new section 2.3.2 Uncrating and positioning the Platform Integrated Cooling Cabinet (pICC) for magnet installation.</li> <li>• Created new section 2.3.2.1 Checking the level of the Platform Integrated Cooling Cabinet (pICC).</li> <li>• Created new section 2.3.2.2 Connecting the cryocooler hoses and cables (equipment room) (for pICC).</li> <li>• Renumbered and renamed existing sections: <ul style="list-style-type: none"> <li>◦ Section 2.3.2 Checking the level of the cabinet is now named Checking the level of the Integrated Cooling Cabinet (ICC) and is section 2.3.1.1.</li> <li>◦ Section 2.3.3 Connecting the cryocooler hoses and cables (equipment room) is now section 2.3.1.2, renamed to Connecting the cryocooler hoses and cables (equipment room) [Integrated Cooling Cabinet (ICC)].</li> </ul> </li> <li>• Removed section 2.3.3, Identifying table anchor positions; this information is now associated with the magnet handling manuals.</li> </ul>

Revision	Date	Description
2	November 2019	<ul style="list-style-type: none"> <li>• Updated Table 1 of section 1.1, Preparing the site, to refer to the <i>SIGNA™ Premier Preinstallation Manual</i> part number instead of the document number.</li> <li>• Updated the last bullet point in section 1.1.1, Introduction, to refer to the updated magnet and anchor positioning section, Identifying table anchor positions.</li> <li>• Updated section 1.2, System components, to include the following: <ul style="list-style-type: none"> <li>◦ 3.0T Magnet and Magnet Enclosure (MAG) and VibroAcoustic Damping Kit</li> <li>◦ Multi-Nuclear Spectroscopy (MNS) [future]</li> <li>◦ High Order Shim (HOS)</li> </ul> </li> <li>• Updated step 1 of section 1.3, Doing an inspection of the product delivery. <ul style="list-style-type: none"> <li>◦ Changed the note about reporting damage to the carrier from a note to substep b.</li> <li>◦ Changed previous substep b to substep c. Updated this step to clarify that the phone number is for Global Parts, not the carrier. The correct option to select when calling this number is option 6, not option 8.</li> </ul> </li> <li>• Made the following updates to section 1.4, Pre-magnet delivery system installation workflow: <ul style="list-style-type: none"> <li>◦ Updated Figure 3 to refer to the <i>SIGNA™ Premier Preinstallation Manual</i> part number instead of the document number.</li> <li>◦ Updated the reference in Figure 3 from "Drawing of Magnet Center Line and Anchor Position" to "Identifying table anchor positions."</li> <li>◦ Removed the following note from the end of the section: "Cryocooler (F-50) will be installed according to the <i>System Installation Manual</i>." This installation will occur either during the Pre-Magnet Delivery System Installation or the System Installation, and both manuals include this procedure.</li> </ul> </li> <li>• Updated Figure 5 and added Table 7 in section 2.1, Installing the Main Disconnect Panel (MDP), to reflect circuit breaker specifications for different VAC.</li> <li>• Updated Figure 6 in section 2.2, Doing a check that pen panel frames are installed. The images of the pen panels were rescaled to correctly align with wall bolts.</li> <li>• Updated section 2.3.1, Uncrating and positioning the Integrated Cooling Cabinet (ICC). <ul style="list-style-type: none"> <li>◦ Updated references to the PIM to be less generic, and specific to the actual title and part number: <i>SIGNA™ Premier Preinstallation Manual (5815067)</i>.</li> <li>◦ Updated steps 24 and 25 to have more clear part terminology.</li> <li>◦ Updated step 26 and added step 27 to add more clarity to the dolly-cabinet lifting process.</li> <li>◦ In step 28, removed the reference to slots on the cabinets. The jack strap is only inserted through slots on the dollies.</li> </ul> </li> <li>• Added section 2.3.2, Checking the level of the cabinet.</li> <li>• Updated section 2.3.3 (formerly section 2.3.2), Connecting the cryocooler hoses and cables (equipment room). <ul style="list-style-type: none"> <li>◦ Updated the section to be consistent in word choice with the <i>Installation Manual</i>.</li> <li>◦ Updated Figure 21 to include callouts and more clear annotations.</li> </ul> </li> </ul>

Revision	Date	Description
		<ul style="list-style-type: none"> <li>◦ Updated step 4 to include the connection of an extension. Also updated the callouts for Figure 23 to be more descriptive, and adjusted where callout 3 was pointing.</li> <li>◦ Updated Figures 24 and 26 to show a 90-degree elbow fitting where the F-50 power cable connects to the cryocooler.</li> <li>◦ Updated the first bullet in step 8 to be more specific to the cable runs. Updated references to the MDP to be prefaced with "GE." Updated the Note about F-50 power to include both GE and customer information.</li> <li>◦ Updated the second bullet in step 8 to refer to Run 833 instead of Run E3024.</li> <li>◦ Updated Figure 26 in step 8. The facility water hoses are now only represented in the fittings on top of the cabinet.</li> <li>• Replaced section 2.4, Doing a check of the magnet positioning lines and anchor position, with Identifying table anchor positions.</li> </ul>
1	December 2017	Initial release





GE HealthCare

[www.gehealthcare.com](http://www.gehealthcare.com)