

# Revolution Maxima/Ace and Optima CT680 Expert

## Pre-Installation

### Operating Documentation



5809942-1EN  
Revision 8



## Effectivity:

The information in this manual applies to the following GE Healthcare CT Scanners:

- Revolution Maxima
- Revolution Ace
- Optima CT680 Expert
- Revolution Maxima Select

The information in this manual does NOT apply to non-fixed (mobile) installations.

## Language Policy

DOC0371395 - Global Language Procedure

ПРЕДУПРЕЖ ДЕНИЕ (BG)	Това ръководство е налично само на китайски (ZH-CN), английски, френски, немски, японски, корейски, полски, португалски (PT-BR), руски, испански и виетнамски. Ако доставчикът на услуги на даден клиент изисква език, който е различен от тези езици, отговорност на клиента е да предостави преводачески услуги.
警告 (ZH-CN)	本手册仅提供中文 (ZH-CN)、英文、法语、德语、意大利语、日语、韩语、波兰语、葡萄牙语 (PT-BR)、俄语、西班牙语和越南语版本。如果客户的服务提供商需要其他语言, 则客户有责任提供翻译服务。
警告 (ZH-HK)	本手冊僅提供中文 (ZH-CN)、英文、法文、德文、意大利文、日文、韓文、波蘭文、葡萄牙文 (PT-BR)、俄文、西班牙文及越南文版本。如客戶的服務供應商需要這些語言以外的版本, 則相關客戶有責任提供有關的翻譯服務。
警告 (ZH-TW)	此手冊僅提供中文 (ZH-CN)、英文、法文、德文、義大利文、日文、韓文、波蘭文、葡萄牙文 (PT-BR)、俄文、西班牙文及越南文版本。假如客戶的服務提供者所需語言版本不在所列語言之中, 客戶需自行負責提供翻譯服務。
UPOZORENJE (HR)	Ovaj je priručnik dostupan samo na kineskom (ZH-CN), engleskom, francuskom, njemačkom, talijanskom, japanskom, korejskom, poljskom, portugalskom (PT-BR), ruskom, španjolskom i vijetnamskom jeziku. Ako klijentov serviser zahtijeva jezik koji nije jedan od tih jezika, odgovornost je klijenta pružiti uslugu prevodenja.
VÝSTRAHA (CS)	Tato příručka je k dispozici pouze v čínštině (ZH-CN), angličtině, francouzštině, němčině, italštině, japonštině, korejštině, polštině, portugalštině (PT-BR), ruštině, španělštině a vietnamštině. Pokud poskytovatel služeb zákazníka vyžaduje jiný jazyk než tyto jazyky, je odpovědností zákazníka poskytovat překladatelské služby.
ADVARSEL (DA)	Denne vejledning findes kun på kinesisk (ZH-CN), engelsk, fransk, tysk, italiensk, japansk, koreansk, polsk, portugisisk (PT-BR), russisk, spansk og vietnamesisk. Hvis en kundes tjenesteudbyder kræver et andet sprog end disse sprog, er det kundens ansvar at levere oversættelsestjenester.
WAARSCHUWING (NL)	Deze handleiding is alleen beschikbaar in het Chinees (ZH-CN), Engels, Frans, Duits, Italiaans, Japans, Koreaans, Pools, Portugees (PT-BR), Russisch, Spaans en Vietnamees. Als de serviceprovider van een klant een andere taal dan deze talen vereist, is het de verantwoordelijkheid van de klant om vertaalservices te leveren.
WARNING (EN)	This manual is available in Chinese (ZH-CN), English, French, German, Italian, Japanese, Korean, Polish, Portuguese (PT-BR), Russian, Spanish, and Vietnamese only. If a customer's service provider requires a language other than these languages, it is the customer's responsibility to provide translation services.
HOIATUS (ET)	See juhend on saadaval ainult hiina (ZH-CN), inglise, prantsuse, saksa, itaalia, jaapani, korea, poola, portugali (PT-BR), vene, hispaania ja vietnami keeles. Kui kliendi teenusepakkujal on vaja juhendit mõnes muus keeles, on tõlketeenuste osutamine kliendi kohustus.

VAROITUS (FI)	Tämä opas on saatavilla vain kiinaksi (ZH-CN), englanniksi, ranskaksi, saksaksi, italiaksi, japaniksi, koreaksi, puolaksi, portugaliksi (PT-BR), venäjäksi, espanjaksi ja vietnamiksi. Jos asiakkaan palveluntarjoaja edellyttää muuta kuin näitä kieliä, käännöspalveluiden tarjoaminen on asiakkaan vastuulla.
ATTENTION (FR)	Ce manuel est disponible uniquement en allemand, anglais, chinois (ZH-CN), coréen, espagnol, français, italien, japonais, polonais, portugais (PT-BR), russe et vietnamien. Si le prestataire de services d'un client nécessite que le manuel soit rédigé dans une autre langue que celles mentionnées ci-dessus, il incombe au client de le faire traduire.
WARNUNG (DE)	Dieses Handbuch ist nur auf Chinesisch (ZH-CN), Englisch, Französisch, Deutsch, Italienisch, Japanisch, Koreanisch, Polnisch, Portugiesisch (PT-BR), Russisch, Spanisch und Vietnamesisch verfügbar. Wenn ein Dienstleister des Kunden dieses in einer anderen Sprache als die genannten benötigt, liegt es in der Verantwortung des Kunden, Übersetzungsdienstleistungen zu erbringen.
ΠΡΟΕΙΔΟΠΟΙΗΣΗ (EL)	Αυτό το εγχειρίδιο είναι διαθέσιμο μόνο σε Κινεζικά (ZH-CN), Αγγλικά, Γαλλικά, Γερμανικά, Ιταλικά, Ιαπωνικά, Κορεατικά, Πολωνικά, Πορτογαλικά (PT-BR), Ρωσικά, Ισπανικά και Βιετναμέζικά. Εάν ο πάροχος υπηρεσιών ενός πελάτη απαιτεί γλώσσα που δεν συμπεριλαμβάνεται σε αυτές τις γλώσσες, αποτελεί ευθύνη του πελάτη να παρέχει υπηρεσίες μετάφρασης.
FIGYELMEZTETÉS (HU)	Ez a kézikönyv az alábbi nyelveken érhető el: angol, francia, japán, kínai (ZH-CN), koreai, lengyel, német, olasz, orosz, portugál (PT-BR), spanyol és vietnámi. Ha az ügyfél szolgáltatója ezektől eltérő nyelvű kézikönyvet szeretne, akkor az ügyfél feladata, hogy gondoskodik a megfelelő fordításról.
ÁÐVÖRUN (IS)	Þessi handbók er aðeins fánleg á kínversku (ZH-CN), ensku, frönsku, þýsku, ítölsku, japönsku, kóresku, pólsku, portúgölsku (PT-BR), rússnesku, spænsku og víetnömsku. Ef þjónustuaðili viðskiptavinar þarfnast annars tungumáls en þessara tungumála er það á ábyrgð viðskiptavinarins að veita þýðingarþjónustu.
AVVERTENZA (IT)	Questo manuale è disponibile solo in lingua cinese (ZH-CN), inglese, francese, tedesco, italiano, giapponese, coreano, polacco, portoghese (PT-BR), russo, spagnolo e vietnamita. Qualora un fornitore di servizi del cliente richieda una lingua diversa dall'inglese, sarà responsabilità del cliente fornire il servizio di traduzione corrispondente.
警告 (JA)	このマニュアルは、中国語 (ZH-CN)、英語、フランス語、ドイツ語、イタリア語、日本語、韓国語、ポーランド語、ポルトガル語 (PT-BR)、ロシア語、スペイン語、およびベトナム語のみで提供されています。お客様のサービスプロバイダがこれらの言語以外の言語を必要とする場合は、お客様の責任において翻訳サービスを提供してください。
경고 (KO)	이 설명서는 중국어(중국어-중국), 영어, 프랑스어, 독일어, 이탈리아어, 일본어, 한국어, 폴란드어, 포르투갈어(포르투갈어-브라질), 러시아어, 스페인어, 베트남어로만 제공됩니다. 고객의 서비스 제공자가 이 언어를 제외한 다른 언어를 요구하는 경우, 번역 서비스를 제공하는 것은 고객의 책임입니다.
BRĪDINĀJUMS (LV)	Šī rokasgrāmata ir pieejama tikai ķīniešu (ZH-CN), angļu, franču, vācu, itāliešu, japāņu, korejiešu, poļu, portugāļu (PT-BR), krievu, spāņu un vjetnamiešu valodā. Ja klientu apkalpošanas speciālistam ir nepieciešama cita valoda, kas atšķiras no šeit norādītajām, klienta pienākums ir nodrošināt tulkotājas pakalpojumu.
ĮSPĖJIMAS (LT)	Šis vadovas pateikiamas tik kinų (ZH-CN), anglų, prancūzų, vokiečių, italų, japonų, korėjiečių, lenkų, portugalų (PT-BR), rusų, ispanų ir vietnamiečių kalbomis. Jei klientų paslaugų teikėjui reikalinga kita nei šios kalba, už vertimo paslaugų suteikimą atsako klientas.
ADVARSEL (NO)	Denne håndboken er bare tilgjengelig på kinesisk (ZH-CN), engelsk, fransk, tysk, italiensk, japansk, koreansk, polsk, portugisisk (PT-BR), russisk, spansk og vietnamesisk. Hvis en kundes tjenesteleverandør krever et annet språk, er det kundens ansvar å levere en oversettelsestjeneste.
OSTRZEŻENIE (PL)	Niniejsza instrukcja jest dostępna wyłącznie w języku chińskim (ZH-CN), angielskim, francuskim, niemieckim, włoskim, japońskim, koreańskim, polskim, portugalskim (PT-BR), rosyjskim, hiszpańskim i wietnamskim. Jeśli usługodawca klienta wymaga języka, który nie został wymieniony powyżej, obowiązkiem klienta jest zapewnienie usług tłumaczeniowych.
ATENÇÃO (PT-BR)	Este manual está disponível somente em chinês (ZH-CN), inglês, francês, alemão, italiano, japonês, coreano, polonês, português (PT-BR), russo, espanhol e vietnamita. Se o prestador de serviços de um cliente necessitar de um idioma diferente dos mencionados, o fornecimento dos serviços de tradução é de responsabilidade do cliente.

ATENÇÃO (PT-PT)	Este manual está disponível apenas em alemão, chinês (ZH-CN), coreano, espanhol, francês, inglês, italiano, japonês, polaco, português (PT-BR), russo e vietnamita. Se o fornecedor de serviços de um cliente necessitar de um idioma diferente dos listados aqui, é da responsabilidade do cliente assegurar os serviços de tradução.
ATENȚIE (RO)	Acest manual este disponibil numai în limbile chineză (ZH-CN), engleză, franceză, germană, italiană, japoneză, coreeană, poloneză, portugheză (PT-BR), rusă, spaniolă și vietnameză. Dacă furnizorul de servicii al unui client solicită o limbă diferită față de aceste limbi, este responsabilitatea clientului să furnizeze servicii de traducere.
ОСТОРОЖНО! (RU)	Настоящее руководство доступно только на китайском (ZH-CN), английском, французском, немецком, итальянском, японском, корейском, польском, португальском (PT-BR), русском, испанском и вьетнамском языках. Если поставщику услуг заказчика требуется руководство на каком-либо другом языке, перевод руководства на необходимый язык осуществляется стороной заказчика.
UPOZORENJE (SR)	Ovaj priručnik dostupan je samo na kineskom (ZH-CN), engleskom, francuskom, nemačkom, italijanskom, japanskom, korejskom, poljskom, portugalskom (PT-BR), ruskom, španskom i vijetnamskom jeziku. Ako korisnik kao pružalac usluge zahteva neki drugi jezik od navedenih, njegova je dužnost da obezbedi prevod.
UPOZORNENIE (SK)	Táto príručka je dostupná len v nasledovných jazykoch: čínština (ZH-CN), angličtina, francúzština, nemčina, taliančina, japončina, kórejščina, poľština, portugalčina (PT-BR), ruština, španielčina a vietnamčina. Ak poskytovateľ služieb daného zákazníka požaduje iný ako tieto jazyky, za poskytnutie prekladateľských služieb zodpovedá zákazník.
ATENCIÓN (ES)	Este manual está disponible solo en chino (ZH-CN), inglés, francés, alemán, italiano, japonés, coreano, polaco, portugués (PT-BR), ruso, español y vietnamita. Si el proveedor de servicios de un cliente requiere un idioma distinto de estos idiomas, es responsabilidad del cliente proporcionar los servicios de traducción.
VARNING (SV)	Den här manualen finns endast tillgänglig på kinesiska (ZH-CN), engelska, franska, tyska, italienska, japanska, koreanska, polska, portugisiska (PT-BR), ryska, spanska och vietnamesiska. Om en kunds tjänsteleverantör behöver ett annat språk än dessa är det kundens ansvar att ordna med översättningstjänster.
OPOZORILO (SL)	Ta priročnik je na voljo v kitajščini (ZH-CN), angleščini, francoščini, nemščini, italijanščini, japonščini, korejščini, poljščini, portugalščini (PT-BR), ruščini, španščini in vietnamščini. Če kupčev ponudnik storitev potrebuje drug jezik, mora za prevod poskrbeti kupec.
DİKKAT (TR)	Bu kılavuz yalnızca Çince (ZH-CN), İngilizce, Fransızca, Almanca, İtalyanca, Japonca, Korece, Lehçe, Portekizce (PT-BR), Rusça, İspanyolca ve Vietnamca dillerinde mevcuttur. Müşteri servis sağlayıcısı bu dillerden başka bir dil talep ederse çeviri hizmeti sağlamak müşterinin sorumluluğundadır.
ЗАСТЕРЕЖЕННЯ (UK)	Цей посібник доступний лише китайською (ZH-CN), англійською, французькою, німецькою, італійською, японською, корейською, польською, португальською (PT-BR), російською, іспанською та в'єтнамською мовами. Якщо постачальник послуг замовника використовує мову, яку не вказано у цьому переліку, послуги з перекладу має забезпечити замовник.

## Damage in Transportation

All packages should be closely examined at time of delivery. If damage is apparent, have notation "damage in shipment" written on all copies of the freight or express bill before delivery is accepted or "signed for" by a GE HealthCare representative or a hospital receiving agent. Whether noted or concealed, damage MUST be reported to the carrier immediately upon discovery, or in any event, within 14 days after receipt, and the contents and containers held for inspection by the carrier. A transportation company will not pay a claim for damage if an inspection is not requested within this 14 day period.

To file a report:

- Call 1-800-548-3366 and use option 6.

- Fill out the GIQ workflow for any items missing, damaged, OBF/FOI for in process installs: <https://app.sc.ge.com>
- Contact your local service coordinator for more information on this process.

Rev. Nov. 10, 2017

## Certified Electrical Contractor Statement

All electrical installations that are preliminary to positioning of the equipment at the site prepared for the equipment shall be performed by licensed electrical contractors. In addition, electrical feeds into the Power Distribution Unit shall be performed by licensed electrical contractors. Other connections between pieces of electrical equipment, calibrations and testing shall be performed by qualified GE HealthCare personnel. The products involved (and the accompanying electrical installations) are highly sophisticated, and special engineering competence is required. In performing all electrical work on these products, GE HealthCare will use its own specially trained field engineers. All of GE HealthCare's electrical work on these products will comply with the requirements of the applicable electrical codes.

The purchaser of GE HealthCare equipment shall only utilize qualified personnel (i.e., GE HealthCare's field engineers, personnel of third-party service companies with equivalent training, or licensed electricians) to perform electrical servicing on the equipment.

## IMPORTANT ... X-Ray Protection

X-ray equipment if not properly used may cause injury. Accordingly, the instructions herein contained should be thoroughly read and understood by everyone who will use the equipment before you attempt to place this equipment in operation. The GE HealthCare will be glad to assist and cooperate in placing this equipment in use.

Although this apparatus incorporates a high degree of protection against x-radiation other than the useful beam, no practical design of equipment can provide complete protection. Nor can any practical design compel the operator to take adequate precautions to prevent the possibility of any persons carelessly exposing themselves or others to radiation.

It is important that anyone having anything to do with x-radiation be properly trained and fully acquainted with the recommendations of the National Council on Radiation Protection and Measurements as published in NCRP Reports available from NCRP Publications, 7910 Woodmont Avenue, Room 1016, Bethesda, Maryland 20814, and of the International Commission on Radiation Protection, and take adequate steps to protect against injury.

The equipment is sold with the understanding that the GE HealthCare, its agents, and representatives have no responsibility for injury or damage which may result from improper use of the equipment.

Various protective materials and devices are available. It is urged that such materials or devices be used.

## Lithium Battery Cautionary Statements

 **CAUTION**



RISK OF EXPLOSION.

Danger of explosion if battery is incorrectly replaced.

Replace only with the same or equivalent type recommended by the manufacturer. Discard used batteries according to the manufacturer's instructions.

**WARNING**



DANGER D'EXPLOSION

Il y a danger d'explosion s'il y a remplacement incorrect de la batterie.

Remplacer uniquement avec une batterie du même type ou d'un type recommandé par le constructeur. Mettre au rebut les batteries usagées conformément aux instructions du fabricant.

## Omissions & Errors

Customers, please contact your GE HealthCare Sales or Service representatives.

GE HealthCare personnel, please use the GE HealthCare PQR Process to report all omissions, errors, and defects in this publication.

## Revision History

Revision	Date	Reason for change
1	July 23, 2019	Initial release.
2	Oct 21, 2019	<p><b>Chapter 5:</b> Section 2.5 update console weight.</p> <p><b>Chapter 6:</b> Section 1.0 update lite table minimum clearance dimension per SPR HCSDM00576892.</p> <p><b>Chapter 8:</b> Update figures 8-15~16, 8-18~21.</p> <p><b>Chapter 11:</b> Add section 3.0 for RSvP information.</p>
3	Dec 11, 2020	<p>Add GT2000 Table information.</p> <p><b>Chapter 1:</b> Update Pre-installation checklist according to DOC1809666_r7.</p> <p><b>Chapter 4:</b> Add UPS and A1 minimum workspace clearances</p> <p><b>Chapter 5:</b> Update system operational clearances and component dimensions.</p> <p><b>Chapter 6:</b> Update minimum service clearances, update rear cover and tube shipping box dimensions.</p> <p><b>Chapter 7:</b> Add Suggested and Typical room size description, update figure 7-1 Minimum Room Size and figure 7-3 Typical Control Room Layout.</p> <p><b>Chapter 8:</b> Add figure for Boom-In-Room Typical Layout and cable routing.</p> <p><b>Chapter 8:</b> Update ceiling requirement and table center-of-gravity.</p> <p><b>Chapter 12:</b> Update feeder and sub-feeder wire size.</p> <p><b>Chapter 13:</b> Update UPS and A1 information.</p> <p><b>Chapter 14:</b> Update system and sub-system delivery consideration.</p> <p><b>Appendix:</b> Update cover removal clearance.</p>
4	Feb 08, 2021	<p><b>Chapter 1:</b> Update Project Manager (PM) to Project Manager of Installation (PMI).</p> <p><b>Chapter 5:</b> Add rear cover dollies in Storage Cabinet.</p> <p><b>Chapter 8:</b> Add ceiling requirement for AVIMOS camera.</p> <p><b>Chapter 8:</b> Update Gantry and PDU sizes in "Component Weight and Floor Loading Data".</p> <p><b>Chapter 10:</b> Update radiation unit to 1mR=8.76uGy.</p> <p><b>Chapter 11:</b> Update SW version to 19BW15.xx for RsVP.</p> <p><b>Chapter 12:</b> Update system rating information 120kV/460mA for 75kVA (55kW).</p> <p><b>Chapter 13:</b> Update GE Supplied cables information.</p>
5	May 18, 2022	<p><b>Chapter 1:</b> Update tilt bed truck to forklift.</p> <p><b>Chapter 4:</b> Update Chapter 4 to separate a part to Appendix.</p> <p><b>Chapter 6:</b> Add express mode camera in Patient Environment.</p> <p><b>Chapter 8:</b> Update express mode information.</p> <p><b>Chapter 8:</b> Add new anchor 5874830/5874830-2.</p> <p><b>Chapter 8:</b> Add Anti-seismic kit information.</p> <p><b>Chapter 9:</b> Update EMI information.</p> <p><b>Chapter 12:</b> Update System Power Requirements.</p> <p><b>Chapter 13:</b> Update option cable list to add depth camera and RCP cables.</p> <p><b>Chapter 14:</b> Update tiltbed truck to forklift.</p>

6	October 27, 2022	<p>Add product name: Revolution Maxiam Select.</p> <p><b>Chapter 1:</b> Update Pre-Installation checklist based on DOC1809666_r8.</p> <p><b>Chapter 5:</b> Add figure for tube change box in Scan Room.</p> <p><b>Chapter 8:</b> Add figure for Boom-In-Room with DVI-Fiber.</p> <p><b>Chapter 8:</b> Update boom installation typical layout.</p> <p><b>Chapter 12:</b> Update ground cable size from 55mm<sup>2</sup> to 50mm<sup>2</sup>.</p> <p><b>Chapter 13:</b> Update A1/MDP drawing, E4502BB, E4502BC and E45021BB.</p>
7	May 15, 2023	<p><b>Chapter 14:</b> Update the section of Lifting based on SPR HCSDM00720264.</p>
8	November 19, 2024	<p><b>Chapter 1:</b> Update pre-installation checklist based on DOC1809666_r9.</p> <p><b>Chapter 6:</b> Update patient environment based on IEC 2431/05.</p> <p><b>Chapter 6:</b> Delete Suggested Room Size and Typical Room Size.</p> <p><b>Chapter 6:</b> Update Short Footprint Considerations.</p> <p><b>Chapter 7:</b> Update Lite Table size based on floor template 5854932DDW.</p> <p><b>Chapter 7:</b> Add Z8G5 information.</p> <p><b>Chapter 8:</b> Update Boom information.</p> <p><b>Chapter 8:</b> Update safety factor value according to 5809939-1EN_r7.</p> <p><b>Chapter 8:</b> Add power box information in Table 8-4 Component Weight and Floor Loading Data.</p> <p><b>Chapter 8/14:</b> Add new lightweight gantry dolly information.</p> <p><b>Chapter 8:</b> Delete anchor lock ring from Table according to MWS.</p> <p><b>Chapter 8:</b> Add Z8G5 information.</p> <p><b>Chapter 9:</b> Add EMC4.1 based on DOC2947691.</p> <p><b>Chapter 12/13:</b> Update facility grounding and insulated copper ground wire description according to service feedback.</p> <p><b>Chapter 12/13:</b> Update feeder cables size per IEC standard based on DOC3061766.</p> <p><b>Chapter 13:</b> Update 5808965 cable length in GE Supplied Long Run Length 5824782-2.</p> <p><b>Chapter 13:</b> Update UPS Wiring Cables information.</p> <p><b>Chapter 13:</b> Update the Cardiac information in GE Supplied Option Cables section.</p> <p><b>Chapter 13:</b> Delete BEVCO information, FE can refer DOC2058932 from SIMS.</p> <p><b>Chapter 15:</b> Tilting not approved for Flat-bed Truck.</p>

Page intentionally left blank

# Contents

<b>1 Introduction</b>	<b>17</b>
1.1 Introduction	17
1.1.1 Using Pre-Installation Manual	17
1.1.2 Assigning a Site Project Coordinator	17
1.1.3 Customer Responsibility	17
1.1.4 Roles and Responsibilities	18
1.2 What is Pre-Installation?	19
1.3 What is Pre-Installation Work?	19
1.4 Pre-Installation Tools	20
1.5 Pre-Installation Checklist	20
<b>2 Installation Types</b>	<b>21</b>
2.1 How to Determine the Best Installation Type for Your Site	21
2.2 Typical Installations	21
2.3 Construction Site Installations	21
2.3.1 Full Construction Site with Completed Radiology Area	22
2.3.2 Full Construction Site with Limited Delivery Access	22
2.4 Relocatable Building Installations	22
2.5 Upgrade Installations	23
2.6 Quick Installations	23
2.7 Two-Step (Temporary) Installations	24
<b>3 System Siting Requirements</b>	<b>25</b>
3.1 System Siting Requirements	25
3.2 Customer System Siting Requirements	25
3.2.1 Regulatory Requirements	26
3.2.2 Electrical	26
3.2.3 Structural	26
3.2.3.1 Dust and Air Quality	27
3.2.3.2 Environmental Influences	27
3.2.3.3 Finished Floor Requirements	27
3.2.3.4 Finished Walls Requirements	28
3.2.4 Radiation Protection	28
3.2.5 Environmental	28
3.2.6 Options	28
3.2.7 Clearances	28
3.2.8 Network	28
3.2.9 Chemical Contamination	29
3.2.10 Delivery	29
3.3 Site Readiness	29
3.3.1 Pre-Installation Delivery Tasks	29

3.3.2 Site Review with Customer .....	29
<b>4 Regulatory Requirements .....</b>	<b>31</b>
4.1 Regulatory Terms and Definitions .....	31
4.2 Regulatory Clearances .....	32
<b>5 Service Clearance Requirements .....</b>	<b>33</b>
5.1 Service Clearance Requirements .....	33
5.2 Service Clearances for Single Service Engineer .....	34
5.2.1 Gantry Service Clearance.....	34
5.2.2 Cover Removal .....	35
5.2.3 Power Distribution Unit (PDU).....	36
5.2.4 Console .....	36
5.2.5 Storage Cabinet.....	37
<b>6 Room Sizes.....</b>	<b>39</b>
6.1 Room Dimensions .....	39
6.2 Minimum Room Size .....	39
6.3 Minimum Room Layouts .....	39
6.4 Short Footprint Considerations.....	40
6.4.1 Instruction of using Short Footprint function.....	41
6.5 Control Room Considerations .....	42
6.5.1 Typical Console Considerations .....	42
6.5.2 Console Long Cable Option .....	43
6.6 Patient Environment .....	44
<b>7 System Component Dimensions .....</b>	<b>45</b>
7.1 Minimum Operating Clearances .....	45
7.1.1 Ceiling Pedestal Mount Installation .....	45
7.1.2 Injector Control Installation .....	45
7.1.3 System Operational Clearances .....	46
7.2 Component Dimensions .....	47
7.2.1 Gantry Dimensions .....	47
7.2.2 Gantry and GT1700V/GT2000 Table Dimensions .....	49
7.2.3 Gantry and Lite Table Dimensions .....	50
7.2.4 Power Distribution Unit Dimensions.....	51
7.2.5 Console Dimensions .....	52
7.2.5.1 Open Console.....	52
7.2.5.2 StandAlone Console .....	54
7.2.5.3 Power Box (Option).....	55
7.2.5.4 Workspace Desk Dimensions .....	56
<b>8 Structural and Mounting Requirements .....</b>	<b>57</b>
8.1 Importance of Meeting Structural Requirements .....	57
8.1.1 Levelness, Vibration, and Floor Loading.....	57

8.1.2	Seismic Loading .....	57
8.1.3	Anchoring .....	57
8.2	Ceiling Requirements .....	57
8.2.1	Regulatory Requirements .....	58
8.2.2	Ceiling Requirement for Boom-In-Room .....	58
8.2.2.1	Ceiling Mounted Devices .....	58
8.2.2.2	Boom Installation Typical Layout .....	59
8.2.2.3	Pedestal Mounting Plate (Supplied by Customer) .....	60
8.2.2.4	Pedestal Height Requirement .....	63
8.2.2.5	Junction (Box) Mounting Plate.....	64
8.2.3	Ceiling Requirement for Auto Patient Positioning Depth Camera .....	65
8.2.3.1	Depth Camera Installation Typical Layout .....	67
8.2.3.2	Junction Plate Requirement .....	68
8.2.3.3	Junction Plate Position .....	73
8.2.4	Ceiling Requirement for AVIMOS Camera .....	76
8.2.4.1	AVIMOS Camera Installation Typical Layout.....	77
8.2.4.2	Junction Plate Requirement .....	79
8.2.4.3	Cable Requirement.....	83
8.3	Minimum Floor Requirements .....	84
8.3.1	Floor Levelness Specification .....	84
8.3.1.1	Critical Specifications .....	84
8.3.1.2	Floor Levelness Guidelines.....	84
8.3.1.3	Measuring Floor Levelness .....	84
8.3.2	Scan Window .....	86
8.3.3	Floor Vibration Specification .....	86
8.3.3.1	Requirements.....	86
8.3.3.2	Sources of Floor Vibration .....	88
8.3.4	Floor Strength .....	88
8.4	Floor Loading and Component Weights .....	89
8.4.1	Floor Loading and Anchoring Guidelines.....	90
8.4.2	Anchor Edge Distance Definition .....	91
8.5	GE-Supplied Anchoring.....	91
8.5.1	Specifications of GE-supplied Anchors .....	91
8.5.2	Requirements for Using GE-supplied Anchors .....	92
8.6	Seismic Mounting.....	95
8.6.1	Overview.....	95
8.6.2	Center-of-Gravity Information .....	97
<b>9</b>	<b>Environmental Requirements .....</b>	<b>105</b>
9.1	Temperature and Humidity Specifications .....	105
9.1.1	Temperature (Scan and Control Rooms) .....	105
9.1.2	Humidity (Scan Room & Control Room) .....	105
9.1.3	Other Guidelines .....	105
9.2	Cooling Requirements .....	106
9.3	Altitude .....	107
9.4	Electro-Magnetic Interference (EMI) .....	108

9.4.1 Gantry .....	108
9.4.2 Console / Computer Equipment.....	108
9.4.3 PDU .....	108
9.4.4 UPS .....	108
9.4.5 EMI Reduction .....	108
9.4.6 Equipment EMI "Envelopes" .....	109
9.5 Electro-Magnetic Compatibility (EMC) .....	110
9.5.1 General Scope .....	110
9.5.2 Electromagnetic Emission .....	111
9.5.3 Electromagnetic Immunity.....	112
9.5.4 Use Limitation .....	116
9.5.5 Installation Requirements and Environment Control .....	118
9.5.5.1 Environment of Intended Use .....	118
9.5.5.2 Cable Shielding and Grounding .....	119
9.5.5.3 Subsystem & Accessories Power Supply Distribution .....	119
9.5.5.4 Stacked Components & Equipment.....	119
9.5.5.5 Low Frequency Magnetic Field.....	119
9.5.5.6 Static Magnetic Field Limit .....	119
9.5.5.7 Electrostatic Discharge Environment & Recommendations.....	119
9.6 System Component Noise Levels .....	120
<b>10 Radiation Protection Requirements .....</b>	<b>121</b>
10.1 Shielding Requirements.....	121
<b>11 Network Requirements.....</b>	<b>125</b>
11.1 Network Connections .....	125
11.1.1 Network Type .....	125
11.1.2 Network Speed.....	125
11.1.3 Network Cable Routing.....	125
11.2 Customer Broadband Responsibilities.....	126
11.2.1 Contact GE to Find Zone Broadband Specialist.....	126
11.2.2 Provide GE with IT Contact Information for the Site .....	126
11.3 Digital Service and Connectivity Requirements .....	126
11.3.1 Background .....	126
11.3.2 InSite RSVP Connectivity Requirements.....	127
<b>12 Power Requirements .....</b>	<b>129</b>
12.1 Introduction.....	129
12.2 System Input Power .....	129
12.2.1 Power Source Configuration.....	129
12.2.2 Rating.....	129
12.2.3 Regulation .....	130
12.2.4 Phase Imbalance .....	130
12.2.5 Sags, Surges and Transients .....	130
12.2.6 Grounding.....	130
12.2.7 Potential Equalization Conductor (Reference IEC 60601-1-2 2007; 2014; 2020) .....	131

12.3 Recommended Power Distribution System .....	131
12.3.1 Using a Dedicated Distribution Transformer (Recommended).....	131
12.3.2 Using an Existing Distribution Transformer .....	132
12.3.3 System Power Requirements .....	132
12.3.3.1 System Power Requirements for 100kVA.....	132
12.3.3.2 System Power Requirements for 75kVA.....	134
12.3.3.3 System Power Requirements for 50kVA.....	135
<b>13 Interconnection Data .....</b>	<b>139</b>
13.1 Introduction.....	139
13.2 Component Designators .....	139
13.3 Interconnect Runs, Wiring and Cables .....	140
13.3.1 GE Supplied System Cable (Open Console) .....	140
13.3.1.1 GE Supplied Standard Length 5824111 (Reference IEC 60601-1-2 2007; 2014; 2020).....	140
13.3.1.2 GE Supplied Long Run Length 5824111-2 (Reference IEC 60601-1-2 2007; 2014; 2020) ..	141
13.3.2 GE Supplied System Cable (StandAlone Console).....	142
13.3.2.1 GE Supplied Standard Length 5824782 (Reference IEC 60601-1-2 2007; 2014; 2020).....	143
13.3.2.2 GE Supplied Long Run Length 5824782-2 (Reference IEC 60601-1-2 2007; 2014; 2020) ..	144
13.3.3 GE Supplied Option Cables (Reference IEC 60601-1-2 2007; 2014; 2020) .....	145
13.3.4 UPS Wiring Cables (Reference IEC 60601-1-2 2007; 2014; 2020) .....	147
13.3.5 A1/MDP-UPS .....	147
13.3.6 Contractor/Customer Supplied .....	148
13.4 Contractor Supplied Components .....	151
13.5 Scan Room Warning Light and Door Interlock.....	151
13.6 Typical Customer Supplied Wiring .....	152
<b>14 Delivery and Storage Requirements .....</b>	<b>153</b>
14.1 Delivery Types and System Lifting and Rigging Restriction .....	153
14.1.1 Loading Dock Deliveries .....	153
14.1.2 Ground (Non-Loading Dock) Deliveries .....	153
14.1.2.1 Liftgate Truck .....	153
14.1.2.2 Tiltbed Truck - NOT Approved .....	154
14.1.2.3 Forklift Truck .....	154
14.1.2.4 Rigging.....	154
14.2 Delivery to the Scan Suite .....	155
14.2.1 Packing Dimension .....	155
14.2.2 Lifting.....	155
14.2.2.1 Stairway Deliveries .....	155
14.2.3 Floor Protection .....	156
14.2.4 Un-loading and un-packing the System .....	156
14.3 Dollies .....	156
14.3.1 Installations within the United States .....	157
14.3.2 Zero Clearance Dollies .....	157
14.3.3 Tilting Table Dollies .....	157
14.3.4 Installations Outside of the United States .....	157
14.4 Gantry Delivery Considerations.....	158

---

- 14.4.1 Gantry Shipping State .....158
- 14.4.2 Door Openings .....158
- 14.4.3 Elevator Requirements .....158
- 14.5 Table Delivery Considerations .....159
- 14.6 Console Delivery Considerations.....160
- 14.7 Storage Requirements.....160
  - 14.7.1 Short-term Storage (Less than Six Months) .....160
  - 14.7.2 Construction-Site Storage .....160
- 14.8 Extreme Temperature Delivery and Storage .....161
- 15 Handling Requirements ..... 163**
  - 15.1 Transportation.....163
  - 15.2 Handling Requirements .....163
    - 15.2.1 Avoid Dropping.....163
    - 15.2.2 Avoid Shocks and Vibrations .....163
    - 15.2.3 Avoid Tipping .....163
    - 15.2.4 Flat-bed Truck Removal (NOT Approved Tilting).....164
- A Regulatory Clearances for US ..... 165**
  - A.1 Regulations.....165
  - A.2 Clearance Requirements.....165
  - A.3 Minimum Regulatory Workspace Clearances by Major Subsystem .....170
  - A.4 How to Measure.....173
  - A.5 NEC Conduit and Duct Fill Rate .....174
- B Alternate Cover Removal Options..... 175**
  - B.1 Overview.....175
  - B.2 Front Cover Removal .....175
  - B.3 Rear Cover Removal.....175

# 1 Introduction

This document contains the physical and electrical data necessary for planning and preparing a site for system installation. The responsibility of arranging and paying for this work rests solely with the purchaser.

## 1.1 Introduction

### 1.1.1 Using Pre-Installation Manual

This manual is the official source of prerequisites to installing a General Electric (GE) Computed Tomography (CT) system. Topics covered are site planning, site preparation, and the system requirements. This manual is divided into requirements for the customer, the system, the environment and on-site construction. It also includes the importance of addressing the local and national regulatory requirements, which may be specific to your location.

A GE Project Manager of Installation (PMI) will be available for specific questions or concerns. The PMI's primary responsibility is to assist the buyer with the siting requirements. This manual is a guide toward the actual installation of your GE CT system. Prior to any construction or installation, GE Headquarters Architectural Planning must approve the completeness of all preliminary concepts, site plans, and final working drawings.

*Pre-installation includes the procurement and installation of ALL requirements, materials, and services necessary for the installation and startup of a CT system.*

### 1.1.2 Assigning a Site Project Coordinator

It is the customers (purchaser) responsibility to assign a site project coordinator. The site project coordinator is the primary contact and liaison between with the construction planners, architects, contractors, and any other site administrative personnel for all site related functions; reporting to the purchaser.

The primary responsibility of the site project coordinator, working closely with GE, is to ensure the purchaser upholds all requirements outlined in this manual. To ensure a successful installation, it is recommended that the site project coordinator manage the entire project from pre-install to final startup, be familiar with all phases of pre-installation and installation of similar medical device construction projects. The site project coordinator should read and understand the contents of this manual and be familiar with the installation procedures.

### 1.1.3 Customer Responsibility

It is the responsibility of the customer to prepare the site in accordance with all the specifications provided in this manual and in conjunction with site-specific drawings and applicable regulations. Consideration should be taken for future expansion during the design phase of the site. It is essential to verify all aspects of the site configuration before construction has begun, as subsequent changes can be costly or impractical.

**Pre-Install Checklist** A detailed pre-installation checklist is provided in this manual. It is the responsibility of the customer to ensure all requirements on the checklist are fulfilled and that the site conforms to all specifications and requirements detailed in this manual.

**Planning and Design Work** The customer will select the location of the site. All architectural, mechanical, and electrical drawings associated with the design and planning of the site are the responsibility of the customer. Any alterations or modifications to the drawings or to products not specifically included in the sales contract are the customer's responsibility. The customer shall provide the site project coordinator, a clean and safe work environment including proper lighting, and a level suitably supported structured floor. All floors, walls and ceiling should be in a finished state prior to installation, and all site-construction renovation completed.

**Regulatory Compliance** The customer shall be solely responsible for all regulatory compliance. All work shall comply with national, state and local regulatory and building codes for the location in which the installation occurs. This includes but is not limited to: permits, inspections, radiation licensing, fire control devices, earthquake regulations, international building codes.

**Electrical Requirements** The customer shall be solely responsible for providing all electrical material and service required as outlined and illustrated in this publication. This includes but is not limited to: Installation of all properly-sized junction boxes, outlets with covers, line safety switches, and fittings installed at the locations specified in the site design. Supplying electrical power of the required voltage, all necessary power supply cables and grounds, all necessary power cables and grounds to the PDU, and an Emergency-Off switch in the scan room.

## 1.1.4 Roles and Responsibilities

- **Customer** : Also known as Buyer or Purchaser or End User. This is the entity that has entered into contract with GE to buy the product.
- **GE Salesperson** : Responsible for completing the customer order process. They coordinate the completion of customer order as desired by the customer, for the customer. They are responsible for correcting incorrect orders. Changing orders, coordinating any replacement of damage in shipment items and for resolving missing in shipment issues.
- **GE Project Manager of Installation (PMI)** : Responsibilities include the overall project coordination and site planning of GE products; manages activities cross-functionally with sales, customer, customer contractors, and local field teams to ensure customer site is designed and prepared to accept and install product in the facility.
- **GE Field Engineer** : GE field personnel responsible for the actual assembly, installation, calibration of the product and verification of the proper operation and configuration of the GE product. This may include the physical movement of the system and its subcomponents from the point of delivery to the scan suite.
- **Zone Broadband Specialist** : GE personnel responsible for providing IT expertise and maintaining records of specific network IT connectivity parameters that are required to properly configure the products' connection to the broadband connection provided by the customer.
- **Network IT Personnel** : Dedicated on site personnel affiliated with or contracted by the customer. Responsible for providing IT expertise necessary to ensure successful network IT connectivity between the GE product and the facility.
- **Qualified Electrician** : Also known as Electrical Contractor. Qualified (Certified by a regulatory agency), In-House individual or entity contracted by the customer. Responsible for electrical connections between customer power source and up to and including the final connection to the GE product.
- **Architectural Engineer** : Dedicated on site personnel affiliated with the customer or contracted by the customer to manage the details of the construction parameters defined by regulatory agencies and as defined by parameters in the GE Pre-installation manual for the proper installation of the GE product.

- **Structural Engineer** : Dedicated on site personnel affiliated with the customer or contracted by the customer to manage the details of the structural parameters defined by regulatory agencies and as defined by the structural parameters provided in the GE Pre-installation manual for the proper installation of the GE product.
- **HVAC Design Engineer** : Dedicated on site personnel affiliated with the customer or contracted by the customer to manage the details of the air conditioning and air handling parameters defined by regulatory agencies and as defined by parameters in the GE Pre-installation manual for the proper installation of the GE product.
- **Independent Contractor** : Person or entity who contracts to do work for another person according to his or her own processes and methods; the contractor is not subject to another's control except for what is specified in a mutually binding agreement for a specific job. Can be contracted by GE personnel or by the customer for a unique or special task as part of the GE product installation process.
- **Customer provided Project Coordinator** : Dedicated contact person that works with GE Project Manager (PM). Acts as the single point of contact for the customer. Coordinates with all persons or entities contracted by the customer for the successful installation of a GE product.
- **Rigger** : Person, persons or entity hired as an Independent Contractor to perform a specific task related to the movement of GE product from the point of delivery to the scan suit where it will be installed.

## 1.2 What is Pre-Installation?

Pre-installation is any site preparation required prior to the installation of the system. This manual states all pre-installation siting and regulatory requirements. The Pre-Installation Kit may not answer all of your questions, contact your GE Project Manager of Installation (PMI) for answers. Likewise, prior to any construction or approval, GE Headquarters Architectural Planning must review all CT site plans, preliminary concepts, and final working drawings. Contact your GE Project Manager of Installation (PMI) for complete information regarding your site-specific room layout.

## 1.3 What is Pre-Installation Work?

Pre-Installation work includes:

- Site renovation.
- Alterations or modifications to products not specifically included in the sales contract.
- Installation of electrical conduit, junction boxes, ducts, outlets, and line safety switches.
- Installation of AWG stranded copper interconnection wiring, conforming to the following requirements:
  - The electrical contractor shall ring out and tag all wires at both ends.
  - Wires shall be continuous and without splices.
  - Ground wires shall conform to product requirements.
  - Color-coded wires shall be used whenever possible, to enable easier identification.
- All work shall conform to IBC (International Building Code) and local building and safety codes.

**NOTE**

GE neither provides nor installs the wires, conduits, junction boxes, or ducts illustrated in this publication, unless specifically mentioned.

## 1.4 Pre-Installation Tools

A list of primary customer tools for successfully completing the pre-installation process for a system is described below.

### Customer Pre-Installation Task

- Regulatory and Service Clearance Information
- System Installation and Alignment Tool (P/N 5824714)

Not included with system, and also available from your PMI/FE from GE tool warehouse. Use this to determine equipment layout and anchoring locations.

- Site Print

Supplied by your PMI or sales rep. Must show actual room size, location of all equipment in the finished room, all service and operating clearances, and meet all regulatory requirements

### Pre-Installation Manual Guide

Table below shows the location of the information necessary for fulfilling each of the pre-installation requirements.

**Table 1-1 Locations of Site Requirement Information in this manual**

Installation Site Requirement Information	
<a href="#">2 Installation Types on page 21</a>	<a href="#">3 System Siting Requirements on page 25</a>
<a href="#">4 Regulatory Requirements on page 31</a>	<a href="#">5 Service Clearance Requirements on page 33</a>
<a href="#">6 Room Sizes on page 39</a>	<a href="#">8 Structural and Mounting Requirements on page 57</a>
<a href="#">9 Environmental Requirements on page 105</a>	<a href="#">10 Radiation Protection Requirements on page 121</a>
<a href="#">11 Network Requirements on page 125</a>	<a href="#">12 Power Requirements on page 129</a>
<a href="#">14 Delivery and Storage Requirements on page 153</a>	<a href="#">15 Handling Requirements on page 163</a>
Contractors must complete ALL WORK before the scheduled delivery date.	

## 1.5 Pre-Installation Checklist

To ensure the latest revision is used, locate DOC2949059 on SIMS Content Viewer.

## 2 Installation Types

### 2.1 How to Determine the Best Installation Type for Your Site

Discuss installation options with your PMI to determine which of the installation types listed below best fits your site and schedule.

- [2.2 Typical Installations on page 21](#)
- [2.3 Construction Site Installations on page 21](#)
- [2.4 Relocatable Building Installations on page 22](#)
- [2.5 Upgrade Installations on page 23](#)
- [2.6 Quick Installations on page 23](#)
- [2.7 Two-Step \(Temporary\) Installations on page 24](#)

### 2.2 Typical Installations

Typical installations occur at established sites with finished, dust-free, occupancy-ready scan suites. The rooms range from suggested to minimum room sizes, and have NO ongoing construction on-site. A typical installation allows customers flexibility for room upgrades and site improvements. Upgrades and improvements may require additional planning prior to system delivery, especially when involving:

- Seismic approval
- Floor structural improvements
- HVAC improvements
- Electrical improvements
- Review of scan room shielding requirements by a qualified radiological health physicist.

As with any installation, the final site design for a typical installation must meet all service and regulatory requirements detailed in this manual.

### 2.3 Construction Site Installations

A *construction installation* describes installation at sites without an occupancy permit, often with ongoing construction. In general, construction sites fail to meet the recommended specifications for delivery of the system. GE does not recommend construction installations, as they can result in delays, increased costs, and possible damage to the system. When construction-site delivery proves unavoidable, the installation falls into one of two categories.

- Full construction site with completed radiology area.
- Full construction site with limited delivery access.

Review the following categories to determine which most closely matches the condition of the planned installation site.

### 2.3.1 Full Construction Site with Completed Radiology Area

This type of site consists of a finished, dust-free, occupancy-ready radiology suite. While there is no remaining construction in or around the scan suite area, there may be ongoing construction in other areas. At the time of delivery such sites feature:

- Dust control measures deployed in the radiology suite area.
- Scan suite access limited to a single entrance (see [Figure 2-1 Full construction site with completed radiology area on page 22](#)).
- Radiology suite sealed off from the remaining construction area.
- Operational HVAC, with a positive air pressure within the radiology suite.

In addition the radiology suite at such a site REMAINS in a dust-free, occupancy-ready state after delivery and throughout the remaining construction phase.

**Figure 2-1 Full construction site with completed radiology area**

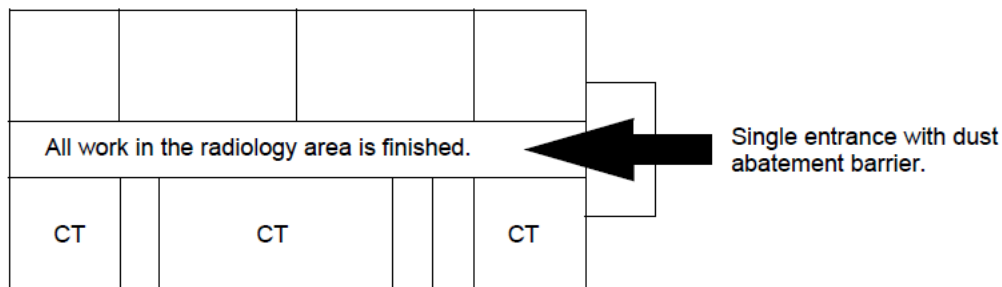

### 2.3.2 Full Construction Site with Limited Delivery Access

This type of site allows delivery during ongoing construction of the radiology suite area. At such sites, delivery occurs prior to site completion, but the product remains stored until a finished, dustfree, occupancy-ready radiology suite area is ready. This type of site requires the system scanner to be delivered in a sealed package with dollies. Delivery to the storage area may require a lift truck or riggers. Installation work begins only when the site reaches the completed, dust-free, occupancy-ready radiology suite requirement.

#### NOTE

If delivery requires vertical or horizontal lifting, the PMI adds the necessary identifier to the order.

## 2.4 Relocatable Building Installations

A re-locatable building is made in a factory and delivered to the site of its permanent location. Relocatable buildings qualify as fixed sites and must satisfy all of the requirements of a fixed site. The gantry and table must be mounted on a solid concrete floor. Any other floor type installations must be designed by the customer's structural engineer and meet all GE Healthcare's specifications listed in this manual.

Refer to the [8 Structural and Mounting Requirements on page 57](#) of this manual for further information.

## 2.5 Upgrade Installations

Upgrade installations occur after the installation of another system. A change in the customer's needs requires the installation of additional equipment at the same site. For example, adding a PET system to an existing CT system.

To proceed with an upgrade installation, the customer's room size must be large enough to accommodate the new product without violating the regulatory and service requirements of the new product. When planning for an upgrade installation, siting requirements of the new equipment may exceed those of your existing system. Requirements needing additional consideration include:

- Floor thickness
- Room shielding
- Additional electrical capacity
- Increased cooling capacity
- Scan room shielding requirements

The final site design must include a room layout showing the equipment room with the recommended room size dimensions. All upgrade installations must meet all service and regulatory requirements detailed in the manual.

## 2.6 Quick Installations

Quick Installations involve sites requiring minimum room improvements. These installations typically consist of a weekend de-installation and room preparation completion, with a next business day delivery and installation.

### Requirements

A site must meet a number of requirements to qualify for a Quick Installation, including:

- Existing electrical disconnect device, wire size, and grounds must meet all requirements referenced in [3.2.2 Electrical on page 26](#)
- Existing structural specifications met, including floor thickness, and all requirements referenced in [3.2.3 Structural on page 26](#)
- Existing HVAC capacity and regulation must meet all requirements referenced in [3.2.5 Environmental on page 28](#)
- Existing CT suite must meet all regulatory and minimum size requirements referenced in [3.2.7 Clearances on page 28](#)
- Existing facility must accommodate delivery and meet all delivery requirements referenced in [3.2.10 Delivery on page 29](#)
- Existing facility must meet all scan room shielding requirements referenced in [3.2.4 Radiation Protection on page 28](#)

Consult your Project Manager of Installation (PMI) for information about any additional requirements.

## Restrictions

The following restrictions govern Quick Installations: check with your PMI regarding floor anchor re-use.

- Quick Installations require a new room print that accurately reflects the rooms targeted for upgrade.
- You **CANNOT** re-use existing floor anchors for a new CT system.
- New floor anchors must be a minimum of 102 mm (4 in) from any existing floor penetrations.
- Rooms not meeting the minimum requirements for the final product must undergo an upgrade/enlargement prior to the installation.

## 2.7 Two-Step (Temporary) Installations

The two-step installation is a temporary installation of one system in a site, with the intention of upgrading the site to another system in a near future date. The following restrictions apply to two-step installations:

- Must comply with ALL siting requirements necessary for the upgraded or final system. This includes the recommended room size and all electrical, structural, and HVAC requirements.
- All requirements referenced in [3 System Siting Requirements on page 25](#) apply to these types of installations.
- The customer is responsible for verifying compliance with all requirements.
- Rooms not meeting minimum requirements for the final product must undergo sufficient upgrading/enlargement.

### NOTE

Temporary installations include all systems installed at a site for a period ranging from two weeks to six months.

## 3 System Siting Requirements

### 3.1 System Siting Requirements

The requirements listed in this manual apply to all fixed-site customer installations, including installation within re-locatable buildings. The following requirements represent the **MINIMUM** that a site must meet before beginning **ANY** new or replacement system installation. All parties should review these requirements to ensure that the site:

- Meets all Service requirements
- Meets all Regulatory requirements
- Meets all minimum structural, flooring, and vibration requirements
- Meets minimum HVAC requirements
- Meets minimum Electrical requirements
- Meets all network requirements
- Meets all radiation protection requirements
- Meets all operational clearances
- Includes all finished doors, floors, windows, ceilings, walls, and all plumbing and cabinets are installed ([3.2.3.3 Finished Floor Requirements on page 27](#) and [3.2.3.4 Finished Walls Requirements on page 28](#) may apply).
- Does not have ANY continuing construction in the scan room OR neighboring suite areas.
- Conforms to the final GE site print, which must be kept ON-SITE and must show all items intended for the finished room.

#### NOTE

Each site should receive a Quick Start Kit from the PMI. Use the Pre-Installation Checklist in this manual to confirm that the site meets all of the requirements listed above. GE recommends completing all work to meet these requirements PRIOR to starting installation.

### 3.2 Customer System Siting Requirements

This section provides a breakdown of the customer tasks crucial for ensuring proper site preparation, regardless of whether planning for a replacement system at an existing site, or designing a new scan room for a first time.

Installation cannot proceed until verification of site-readiness occurs. A site is ready **ONLY** when it meets ALL delivery, regulatory, system, network, radiation protection, and operational requirements, as well as, requirements for any options. The purchaser is responsible for completing all work necessary to install the system, and includes:

- Completion of all items in [3.2.3 Structural on page 26](#) (recommended before installation begins.)
- PMI verification that ALL items on the Pre-Installation Checklist are completed.
- Review and preparation of all site-ready items.

To ensure timely delivery and installation, GE recommends that the customer complete all necessary work and schedule a site-ready visit prior to the delivery date. To confirm that the site meets all requirements, you may need to employ these and other contractors:

- Structural Engineer and/or Architect
- HVAC Contractor
- Electrical Contractor
- Qualified Radiological Health Physicist
- Cleaning Services.

**NOTICE**

An improperly prepared site—one that is in a state of construction—can result in a delayed installation date and/or damage to the system.

### 3.2.1 Regulatory Requirements

Verify that the site conforms to all of the following:

- The room must meet all regulatory clearance requirements.
- The room must meet all minimum size requirements.
- The site print is on-site, reflects actual room size and layout, and has received final approval.
- No grounded walls are found in regulatory clearance areas.
- The room meets all local codes.

### 3.2.2 Electrical

- Install the correct size junction boxes with covers at locations shown in the installation plan.
- Install appropriate conduits and duct work for system cables. If the suite houses additional components, determine the necessary considerations and complete the connections.
- Install a power supply of correct voltage output and adequate kVA rating.
- Install local disconnects, including proper over-current protection. This includes the A1/MDP main disconnect with Lock-out and Tag-out (LOTO) installation.

### 3.2.3 Structural

- Install “steelwork” or other suitable support work for mounting equipment from walls or ceilings.
- Review structural requirements including:
  - floor vibration
  - floor levelness
  - floor thickness
  - any seismic considerations, if applicable.
- Complete all suite and room renovations and modifications prior to delivery.

### 3.2.3.1 Dust and Air Quality

Ensure that the scan suite area is free of all dust, and not subject to ANY ongoing construction, including the installation of cabinets, hanging doors, and ceiling tiles.

**CAUTION**

POTENTIAL EARLY SYSTEM FAILURE.

Fine dust can deposit on the internal electronic components in Gantry, DAS, Tube, Table, PDU, and Operator Console.

It results in potential damage to the electronic components and lead to an early system failure.

Before installing scanner systems, ensure that the scan suite area is free of all dust and not subject to any ongoing construction.

**TYPES OF DUST TO AVOID** Ensure that NO construction occurs in or immediately around the scan suite area that results in:

- concrete dust
- drywall dust
- ceiling tile dust
- wood sawdust or shavings
- dust tracked into the CT suite from adjoining rooms

Failure to take appropriate precautions to protect the system against these types of dust may result in DAMAGE to the system and early SYSTEM FAILURE.

### 3.2.3.2 Environmental Influences

CT systems are designed with commercial components that are sensitive to air contaminants like sulfide, chloride and nitrates. It is the responsibility of the purchaser to ensure that the levels of these contaminates are low (Class1). See IEC60654-4 for air quality guidelines.

### 3.2.3.3 Finished Floor Requirements

**NOTE**

If a customer does not have concrete floor for the system installation, then the required anchoring must be approved by customer's structural engineer. It is customer's responsibility to finish the flooring.

Installation requires a finish floor in the scan and control rooms. The floor surface in the scan room directly under the gantry and table must be level. The scan room must be level by 6 mm (1/4 in) over the table and gantry area to be acceptable. Shims should not be used to compensate for a floor that does not meet this requirement. Eight or more floor covering openings that are 102 mm (4 in) in diameter are made to ensure the table and gantry rest on a solid surface. These floor penetrations can be sealed if required. These requirements apply to all installation types.

***Finished Floor Exception 1***

For sites replacing their scan room floor covering after the table and gantry are installed, the floor can be clean-finished with dust free concrete. The finish floor in the scan room requires no dust-producing operations when applying final floor covering.

#### ***Finished Floor Exception 2***

Facilities under new construction that have a finished radiology area with a single controlled-access and dust abatement barrier, can have a finished concrete floor in the scan room. The finished concrete floor in the scan room requires no dust-producing operations when applying final floor covering.

### **3.2.3.4 Finished Walls Requirements**

Finished walls inside the scan and control rooms must be painted at the time of installation. This requirement applies to all installation types. A finished walls exception is made for new construction and upgraded facilities. A primer coat of paint is acceptable for equipment installation. However, the final coat of paint must be applied using a brush of some type (roller, or bristle). The final coat of paint cannot be applied using a spray method.

### **3.2.4 Radiation Protection**

A qualified radiological health physicist should verify that the scan room's radiation shielding provides adequate radiation protection for the planned system. Refer Shielding Requirements for more details.

### **3.2.5 Environmental**

Review HVAC requirements, including system environmental controls and patient comfort needs. Make sure the site provides an HVAC system capable of maintaining the recommended temperature and humidity specifications at the time of installation.

### **3.2.6 Options**

- Confirm that all customer installation options are reviewed and final locations determined.
- All GE supplied installation options are reviewed and final locations determined.
- The laser camera should be on site at the time of system installation.

### **3.2.7 Clearances**

- Review operational clearances to verify whether daily use items fit (e.g. beds, carts).
- Consider clearances for emergency medical equipment.
- Ensure that all storage cabinets and sinks appear on the site print in their proper locations.
- Confirm that adequate space exists in the scan suite for delivery and installation of all replacement parts following installation of the system.

### **3.2.8 Network**

Ensure that network communication is in place and active.

## 3.2.9 Chemical Contamination

Never install wet film processors in the same room as the scanner, as this may result in possible contamination of scanner components. Chemicals utilized by such processors can contribute to increased equipment failures and downtime, and decreased reliability.

When siting this equipment, consider the effects that contact with these chemicals and the resulting fumes might have on human subjects in proximity to them. In addition, film processor equipment installation must meet all manufacturer requirements (e.g. ventilation specifications) as well as all applicable local, state, and national codes.

## 3.2.10 Delivery

- Determine room dimensions and verify that doorways adequately accommodate the system.
- Verify the existence of an accessible dust-free non-construction zone route to the scan suite that accommodates delivery.
- Identify elevators, doorways and hallways that can accommodate delivery.
- Provide floor protection, if needed.
- Request rigging, if needed.

## 3.3 Site Readiness

The GE Healthcare Project Manager of Installation (PMI) assists the purchaser in meeting all system siting requirements.

### 3.3.1 Pre-Installation Delivery Tasks

The PMI also performs the following pre-installation delivery tasks:

- Determines the delivery type: ground, dock.
- Determines if the delivery requires tilt dollies or riggers; orders dollies and lifting crates, as needed.
- Determines if the delivery requires the use of floor protection.
- Determines if the ground delivery requires the use of a forklift, and informs GE Transportation of the need for a forklift.

### 3.3.2 Site Review with Customer

A site-ready visit should occur prior to the delivery date. This visit verifies that the site meets all system siting requirements and confirms that installation can proceed. During the site-ready visit, a GE representative confirms that the site meets all of the required site-ready conditions including floor levelness, and delivery route readiness. Lifting options and construction site packaging must be ordered prior to delivery and cannot be added on-site.

Page intentionally left blank

## 4 Regulatory Requirements

### 4.1 Regulatory Terms and Definitions

#### **CLEARANCES**

Clearances are the clear space or distance between or around objects and equipment, governed by all applicable safety, service and regulatory requirements and representing the lowest margin of freedom permissible for equipment siting.

#### **DIMENSIONS**

The length, width, depth and height of equipment.

#### **EGRESS**

An egress is the single path of exit from within any room. It is the customer's responsibility to provide a means of egress.

#### **PRE-INSTALLATION ESCALATION**

Pre-installation escalation is the process used to consult CT Engineering, the Design Center, or Environmental Health and Safety (EHS) to resolve preinstallation issues related to siting concerns and requirements.

#### **GROUNDING WALL**

A grounded wall is any wall with electrical conductivity to earth. Conductive materials generally found in walls include masonry, concrete, and tile. Treat as grounded additional elements commonly found in walls, including but limited to:

- Medical gas ports and plates
- Metal doors and window frames
- Water sources and metallic sink structures
- Metallic wall mounted cabinets
- A1 main disconnect panel
- Equipment Emergency Off panels
- Industrial equipment (such as air conditioners and vents)
- Expansion joints
- Surface raceway
- Exposed wall conduits
- Floor outlet boxes
- Floor HVAC boxes
- Floor medical gas

Common wall components **NOT** constituting grounded elements include:

- Standard wall outlet

- Light switches
- Telephones
- Communication wall jacks
- Ceiling tile grids

**HEAD CLEARANCE**

Head clearance represents the height dimension of the workspace, measured from the floor at the front edge of the equipment to the ceiling or any overhead obstructions. It requires a minimum of 1981 mm (78 in) of the height of the equipment, whichever is greater.

**MINIMUM**

Minimum indicates the lowest limit permitted by law or other authority.

**SERVICE ACCESS WIDTH**

Service access width refers to the width of the working space in front of the equipment, and requires a minimum of 762 mm (30 in) or the width of the equipment, whichever is greater.

**WORKSPACE**

The workspace represents a three dimensional box of space required for safe inspection or service of energized equipment. It consists of depth, width, and height, with the depth dimension measured perpendicular to the direction of access. US regulation requires a minimum depth of 914 mm (36 in). Additional conditions can increase the minimum requirement. For example, FCT defines workspace as the envelope of the component superstructure, measured for the PDU with the front panel removed, and measured for the gantry and table with the extended covers removed.

## 4.2 Regulatory Clearances

Refer to [A Regulatory Clearances for US on page 165](#) for United States (US) installations.

# 5 Service Clearance Requirements

## 5.1 Service Clearance Requirements

- Sufficient space to remove the covers [Figure 5-1 Minimum Service Clearances on page 33](#).
- One service engineer shall be able to accomplish all service component replacement tasks without needing special tools or equipment.
- ALL room layouts to provide service space and access around the table to the gantry right side. This is needed for replacement procedures that require components that are shipped in large boxes, such as the tube, detector, and HV tank.

**Figure 5-1 Minimum Service Clearances**

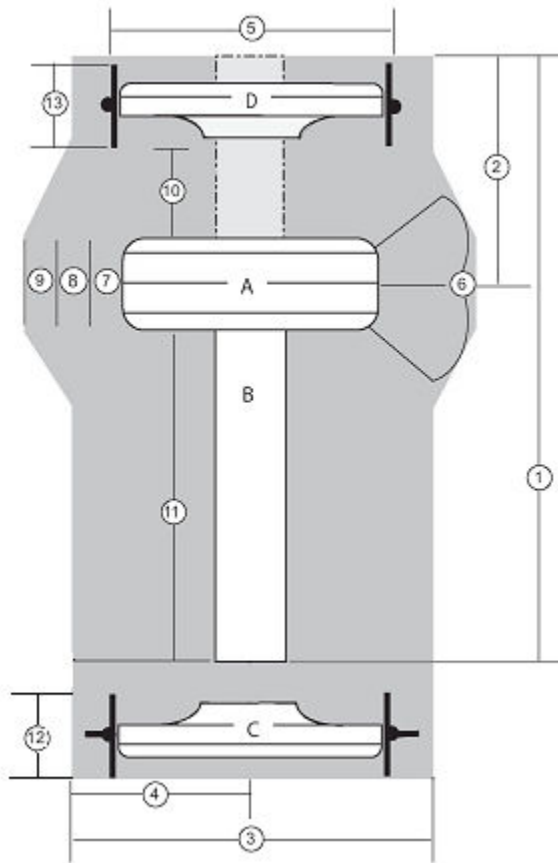

Minimum Service Clearances		
Item		Dimension
1	GT2000	5716 mm (225 in.) (travel distance of table, with cradle extender)
	GT1700V	4840 mm (191 in.) (travel distance of table, with cradle extender)
	Lite Table	4611.9 mm (181 in.) (travel distance of table, with cradle extender)
2	GT2000	2010.4 mm (79 in.) (scan center to cradle max travel, with cradle extender)

Minimum Service Clearances		
	GT1700V	1708.4 mm (67 in.) (scan center to cradle max travel, with cradle extender)
	Lite Table	1628 mm (64 in.) (scan center to cradle max travel, with cradle extender)
3		2830 mm (112 in.)
4		1415 mm (56 in.)
5		2501 mm (98.5 in.)
6		914 mm (36 in.) (minimum separation distance)
7		356 mm (14 in.)
8		711 mm (28 in.)
9		914 mm (36 in.)
10		914 mm (36 in.)
11	GT2000	3315.6 mm (130.5 in.) (table height is 485 mm)
	GT1700V	2741.6 mm (108 in.) (table height is 485 mm)
	Lite Table	2609 mm (102.7 in.) (table height is 494 mm)
12		899 mm (36.7 in.)*
13		750 mm (30.6 in.)
*: If the gantry front cover is not parked at table rear, the clearance can be reduced to 356 mm (14 in.).		
CT Components		
Item	Description	
A	Gantry with covers installed	
B	Table cradle footprint, coverage as extended in both directions	
C	Gantry front cover removed with dolly	
D	Gantry rear cover removed with dolly	

## 5.2 Service Clearances for Single Service Engineer

### NOTE

When calculating service clearances, refer to [Figure 5-1 Minimum Service Clearances on page 33](#) for all service clearance needs.

### 5.2.1 Gantry Service Clearance

Specifications for Boom Assembly clearance arc are defined in [Figure 5-2 Boom Assembly Clearance on page 35](#). The boom assembly is used during tube and detector replacement. The minimum ceiling height within the clearance radius is 2286 mm (90 in).

Figure 5-2 Boom Assembly Clearance

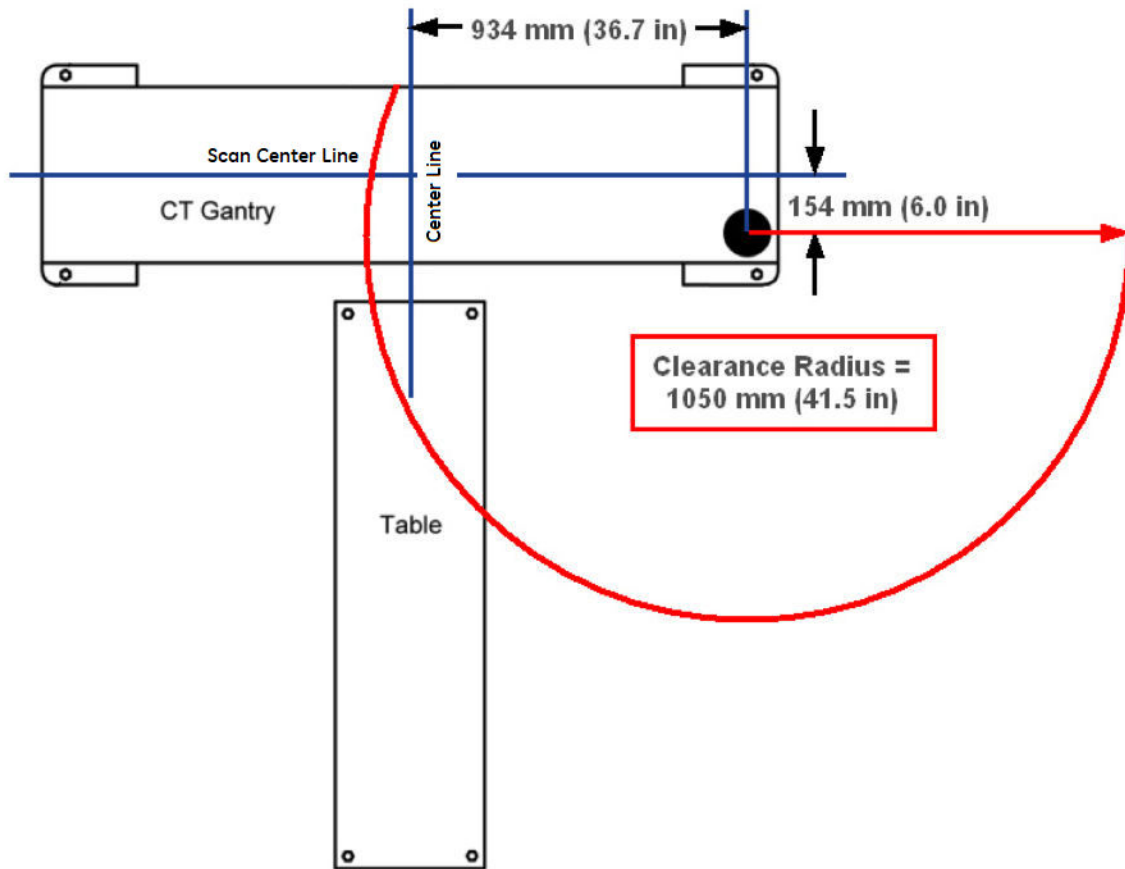

## 5.2.2 Cover Removal

- Gantry front cover removal requires the use of the Tilting Cover Dollies and a minimum clearance space of 2830 mm (112 in.) to maneuver the cover, as illustrated in [5.1 Service Clearance Requirements on page 33](#). The dollies allow the service engineer to separate the cover from the gantry, tilt it 90 degrees, roll it to the foot end of the table, and then tilt it an additional 90 degrees, so that it is upside-down relative to its normal system-mounted condition. After removal, the service engineer must then move the gantry front cover to a position that satisfies the minimum regulatory clearances.
- The gantry rear cover, with service dollies installed, requires a clearance width of 2501 mm (98 in.) and a depth of 914 mm (36 in.) for removal, as shown in [5.1 Service Clearance Requirements on page 33](#). Sufficient space to allow the service engineer to move the cover either straight back or to one side of the table to satisfy the minimum service clearances shown in [5.1 Service Clearance Requirements on page 33](#) must be maintained. The rear cover with dollies cannot extend past the allowable clearance space within the room (see [5.1 Service Clearance Requirements on page 33](#)). If the system is not sited straight (it is positioned diagonally), full service space is still required. The PMI and customer should discuss this consideration and make the necessary provisions.
- The scan room must offer sufficient space to allow adequate egress during service operations that require both front and rear cover removal. If the customer and PMI have any concern that site will not provide adequate space for egress under these conditions, they should discuss these requirements and make the necessary provisions to accommodate this event.

- A single service engineer can safely perform servicing of the table. Ensure sufficient clear space to maintain egress clearances with the table covers or cradle removed.
- A single service engineer can safely perform servicing of the system. Ensure sufficient clear space to maintain egress clearances with covers or cradle removed.
- A tube change box is 1016 mm (L) x 711 mm (W) x 737 mm (H) (40 in. x 28 in. x 29 in.), if the handles are extended, the box dimension is 1813 mm (L) x 711 mm (W) (71 in. x 28 in.). The box rolls like a wheelbarrow and must have access to the right side of the gantry. It is the PMI's responsibility to demonstrate that the tube change box can be positioned in the tube change area next to the gantry and that the front and rear covers can be removed.

**Figure 5-3 Tube Change Box Delivery (example)**

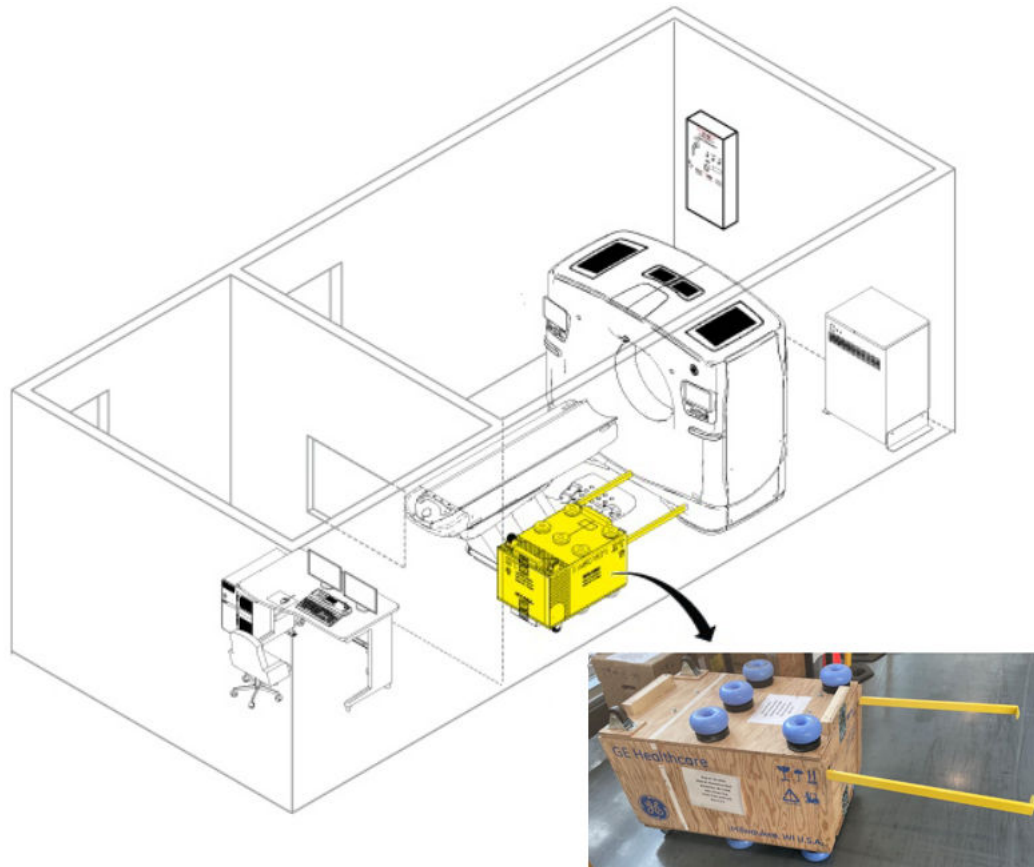

### 5.2.3 Power Distribution Unit (PDU)

When positioning the Power Distribution Unit (PDU), consider regulatory compliance, as defined in Regulatory Clearances. See [Table A-2 PDU – Minimum Workspace Clearances on page 170](#) in that section.

### 5.2.4 Console

As some service activities require access to the rear of the console, be sure to maintain sufficient space for moving the console to allow rear service access.

See [Figure 6-3 Typical Control Room Layout on page 43](#) for a typical control room layout.

## 5.2.5 Storage Cabinet

GE Healthcare provides a storage cabinet (see Note below) for storing all supplied service equipment (see [Table 5-1 Equipment Stored in Storage Cabinet on page 37](#)). Situate this storage cabinet within the scan room suite area to allow easy service access. The dimensions of the cabinet measure 610 mm D x 914 mm W x 1067 mm H (24 in. D x 36 in. W x 42 in. H), complete unit not to exceed 68kg (150 lbs) (empty).

### NOTE

A storage cabinet is provided as option (B77292CA).

**Table 5-1 Equipment Stored in Storage Cabinet**

Item	Size	Weight (total)	
QA Phantom (water filled)	20 cm x 15 cm (7.9 in. x 5.9 in.)	5.5 kg	12 lb
Phantom Holder	25 cm x 25 cm (9.8 in. x 9.8 in.)	3.6 kg	8 lb
FE Box (Purple)	30 cm x 38 cm x 30 cm (11.8 in. x 15 in. x 11.8 in.)	6.8 kg	15 lb
Install Support Kit (box)	30 cm x 30 cm x 38 cm	9.1 kg	20 lb
Three Piece Tube Hoist Assembly	77 cm x 8 cm and 38 cm x 15 cm (30.3 in. x 3.1 in. and 15 in. x 5.9 in.)	9.1 kg	20 lb
Balance Weight Kit		33 kg	73 lb
Front Cover Dollies	85 cm x 20 cm and 85 cm x 15 cm (33.5 in. x 7.9 in. and 33.5 in. x 5.9 in.)	~15.9 kg	35 lb
Rear Cover Dollies	70 cm x 135 cm	~11.5 kg	25 lb

Page intentionally left blank

## 6 Room Sizes

### 6.1 Room Dimensions

**Table 6-1 Scan Room Minimum Size Dimensions**

System Configuration	Minimum Room Size
System with GT2000 Table	6223mm * 3327 mm (20.4 ft * 10.9 ft)
System with GT1700V Table	5563 mm * 3327 mm (18.3 ft * 10.9 ft)
System with Lite Table	5377 mm * 3327 mm (17.6 ft * 10.9 ft)
 <b>NOTE</b> All service/regulatory requirements apply in accordance with country specific regulations. All service/regulatory requirements apply, with the addition of no energized left-side service. Minimum room size includes Axial Head Holder and Extender.	

### 6.2 Minimum Room Size

The minimum room configuration represents the smallest functionally acceptable space for this product and represents the type of room often found at doctor's offices and smaller clinics and outpatient facilities. Due to its limited size, and to functional and regulatory requirements, this room usually provides only LIMITED workspace, and leaves to NO space to add in-room millwork and sinks and still meet the necessary regulatory and service requirements. This room can accommodate the transportation of patients into the scan area using wheelchairs, and provides access for crash carts and other emergency medical equipment on only one side of the table.

Sites considering a minimum room size may not have been designed with the structural requirements necessary to support the system and consequently may require upgrading prior to installation.

Customers considering a minimum room size should discuss their workspace requirements and future upgrade plans with their PMI, as the size and layout of these rooms often eliminates them from any future upgrade considerations and offers NO compatibility with future two-step installations.

If using the square meters (square footage) to determine regulatory compliance, please note that the front and rear cover clearances are wider than the regulatory clearance along the table length, and that the cover park position is behind the table in the home position.

**NOTE**

Sites must provide sufficient space to allow the removal of the rear cover, which is on wheels, from behind the gantry during service operations.

### 6.3 Minimum Room Layouts

**Room A** - Less than 711 mm (28 in.), but greater than 356 mm (14 in.) of space on the gantry left side, measured from covers to left side wall, compromising service, egress, and workspace on the gantry's left side.

**Room B** - Less than 914 mm (36 in.), but greater than 711 mm (28 in.) measured from the covers to the left sidewall. In this configuration service, egress, and workspace are acceptable around the gantry.

**Figure 6-1 Minimum Room Size**

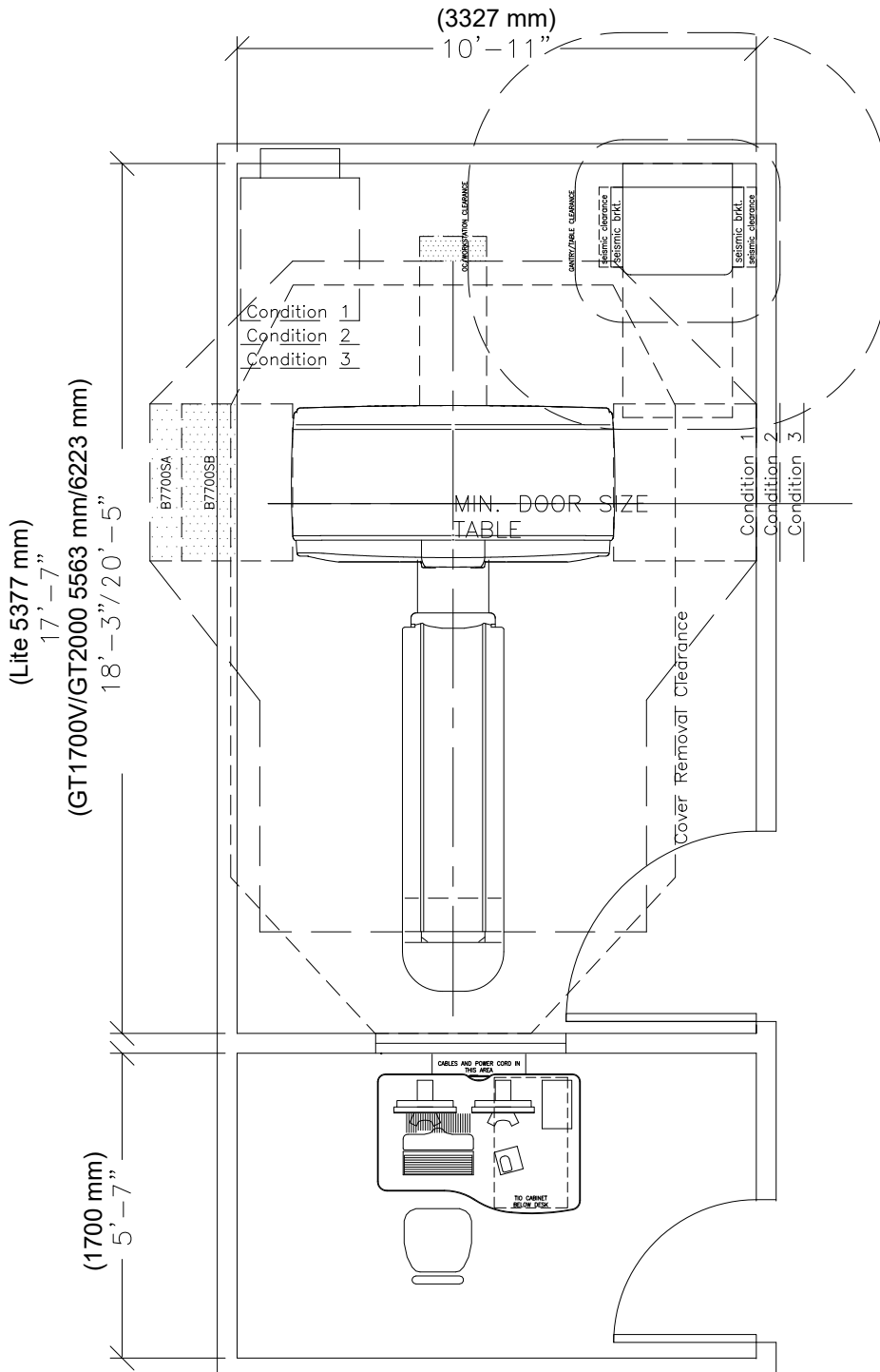

## 6.4 Short Footprint Considerations

If the site room length cannot satisfy the requirements for standard mode. Short Footprint mode can be considered. This feature is for both GT1700V Table and Lite Table.

The Short Footprint mode limits the distance of the cradle travel so that cradle does not collide with the wall behind Gantry. The scannable range is limited accordingly.

The Short Footprint features are as follows:

- Cradle Movement limitation can be set at any position.
- Table height limitation cannot be set.
- Scannable range depends on the Gantry Rear space (distance to the wall), but need to consider the Service Clearance and country's local regulation for Gantry Rear space.

## 6.4.1 Instruction of using Short Footprint function

### NOTICE

Cradle limitation must comply with country or local regulatory clearance requirements. Cradle movement limitation set by short footprint mode must be approved by customer during pre-installation.

Figure 6-2 Short Footprint Calculation diagram

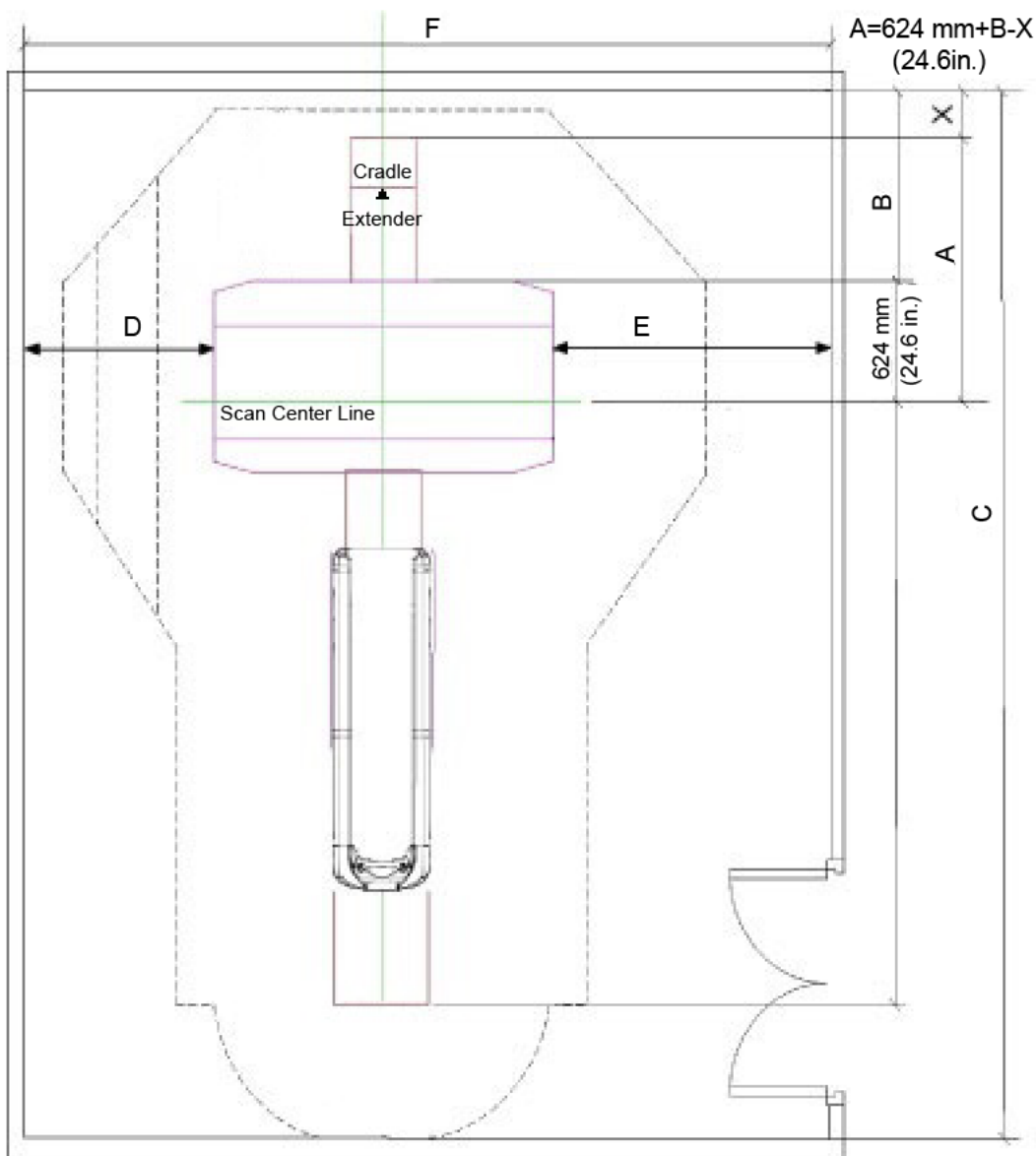

A: Cradle Scannable Limitation, the value to be set using Short Footprint function A (Scannable Range (approx.) = 624mm (24.6in.) (Scan Center Line to Gantry Rear Cover) + B (Gantry Rear Cover to Wall) - X (Safety Clearance to prevent hitting cradle to wall).

B: Gantry rear cover to wall.

C: Room Length

D: Gantry left side to wall.

E: Gantry right side to wall.

F: Room Width

X: Distance from cradle limitation to wall, no less than 152 mm (6 in).

## 6.5 Control Room Considerations

- The control room must provide an operating environment suitable for the console electronics and the operator's working comfort. See [9 Environmental Requirements on page 105](#).
- As the console requires adequate venting, maintain 96 mm (4 in.) of clear, unobstructed space on all sides of the console to allow the four fans located on the rear of the console to exhaust air to both the left and right.
- Provide a suitable work area within reach of the console for the placement of the injector control. Injector controls differ in dimensions depending on the brand selected.
- A PACS, workstation, image printer, or filming device may appear in the console control room area. These devices or other components, though having a direct link to the console via network or ethernet cable, shall NOT receive power from the console (if outlets exists on the console). If you are using additional devices or components, consider additional room power and network connections when reviewing the console workspace.

### 6.5.1 Typical Console Considerations

- The console must remain in the same configuration as shipped. Do not dismantle the console, or remove or rearrange its components.
- Cable lengths must remain as shipped (cables cannot be cut or extended to mount the monitor on the customer's counter).

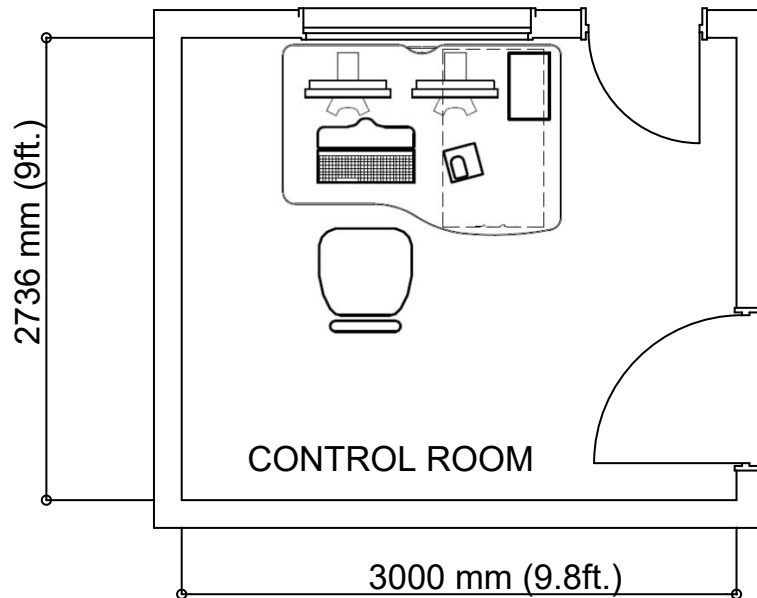
**Figure 6-3 Typical Control Room Layout**

## 6.5.2 Console Long Cable Option

Console cabinet can be placed approximately 3 meters away from LCD monitor, GSCB and keyboard by using Long Cable Option.

Refer to Console Long Cable Option Installation Manual (Direction 5456816-1EN) for the details.

### **NOTICE**

When install the console cabinet in the scan room, do not place it within the patient environment. Refer to [6.6 Patient Environment on page 44](#) for the details.

## 6.6 Patient Environment

The patient environment is defined as the following picture.

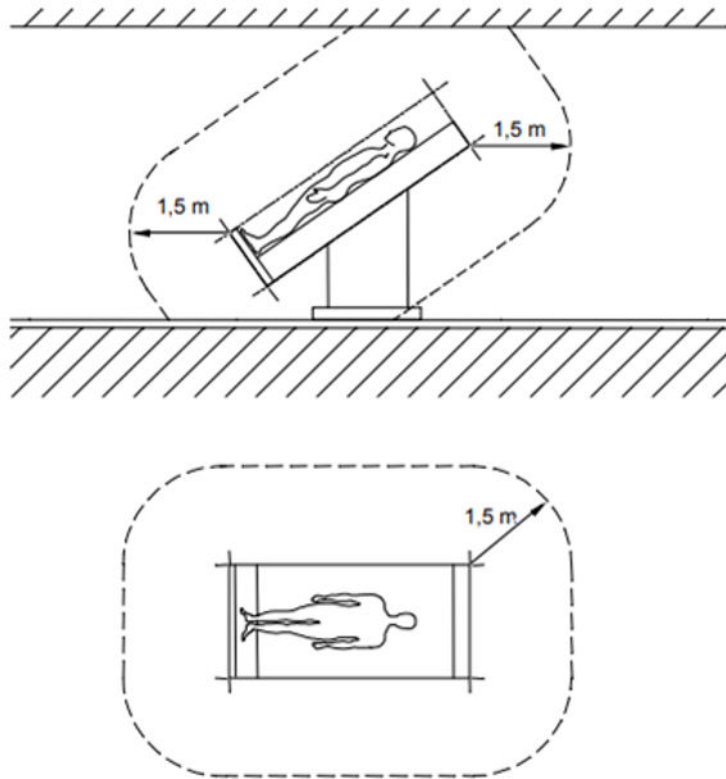

IEC 2431/05

Only Scanning Gantry, Patient Table components and the following options can be placed in this area.

- Advantage 4D
- In room monitor
- SmartStep
- Extream Injector
- Express Mode Camera
- AVIMOS Camera

## 7 System Component Dimensions

### 7.1 Minimum Operating Clearances

The sections in this chapter provide the minimum dimension and operating clearance information for each category of components listed. Be sure that the site conforms to each of these specifications.

#### 7.1.1 Ceiling Pedestal Mount Installation

The distance from the floor to the lowest point of the ceiling pedestal mount for the Injector or Monitor CANNOT measure LESS than 2134 mm (84 in.). Refer to the installation guides of those components for the length of the mounting post.

**NOTE**

The down post or ceiling mounted pedestal used to mount injectors, remote monitors or other devices shall not be installed within the tube crane area. See [5.2.1 Gantry Service Clearance on page 34](#).

**NOTICE**

Failure to maintain a distance of at least 2134 mm (84 in.) from the floor to the lowest point of the Injector or Monitor ceiling pedestal mount may pose a safety hazard. For installations with a finished ceiling height that is less than suggested, consideration should be given to utilizing floor mounted components, or attaching the mounting plate in the overhead (for example, above dropped ceiling tiles).

#### 7.1.2 Injector Control Installation

Minimum dimensions and clearances include the following requirements for the injector control:

- Provision of a suitable work area for placement of the injector control, within reach of the console.
- Wall mounted, ceiling mounted, and pedestal units require routing of cables from the gantry area to the console area. The supplied cable measures 15.2 m (50 ft).
- Injectors require an AC power source that is powered from the console. The IEC power cord is supplied with the injector.
- Available mounts come in several different lengths and configurations. Refer to the injector documentation for detailed installation instructions.

**NOTE**

The console requires IEC power plugs to power GE approved options. All Options used with the system must be powered using the console or gantry power plugs.

For systems using any NEC power plugs, Options (such as Video splitter) must be plugged inside the console power strip.

## 7.1.3 System Operational Clearances

The clearances listed in [Table 7-1 Minimum Dimensions and Operational Clearances on page 46](#) govern system operation; be sure that the site maintains each of these clearances.

**Table 7-1 Minimum Dimensions and Operational Clearances**

System Operation	mm	inches
Ceiling Pedestal mount (optional) lowest point to floor injector or monitor	2134 mm	84 in.
Finished ceiling to floor (suggested)	2743 mm	108 in.
Finished ceiling to floor (minimum)	2286 mm	90 in.
Table to maximum extension head end with extender from center line	2010.4 mm (GT2000 Table)	79 in.
	1708.4 mm (GT1700V Table)	67 in.
	1628 mm (Lite Table)	64 in.
Table extension head end with extender to obstruction	152 mm	6 in.
Table in lowest position with cradle at home position to surface of Gantry front cover	3315.6 mm (GT2000 Table)	130.5 in.
	2741.6 mm (GT1700V Table)	123 in.
	2594 mm (Lite Table)	102.1 in.
Back of Console to wall	102 mm	4 in.
Back of PDU to wall	152 mm	6 in.

# 7.2 Component Dimensions

## 7.2.1 Gantry Dimensions

Figure 7-1 Gantry with Covers Dimensions

Unit: mm (in)

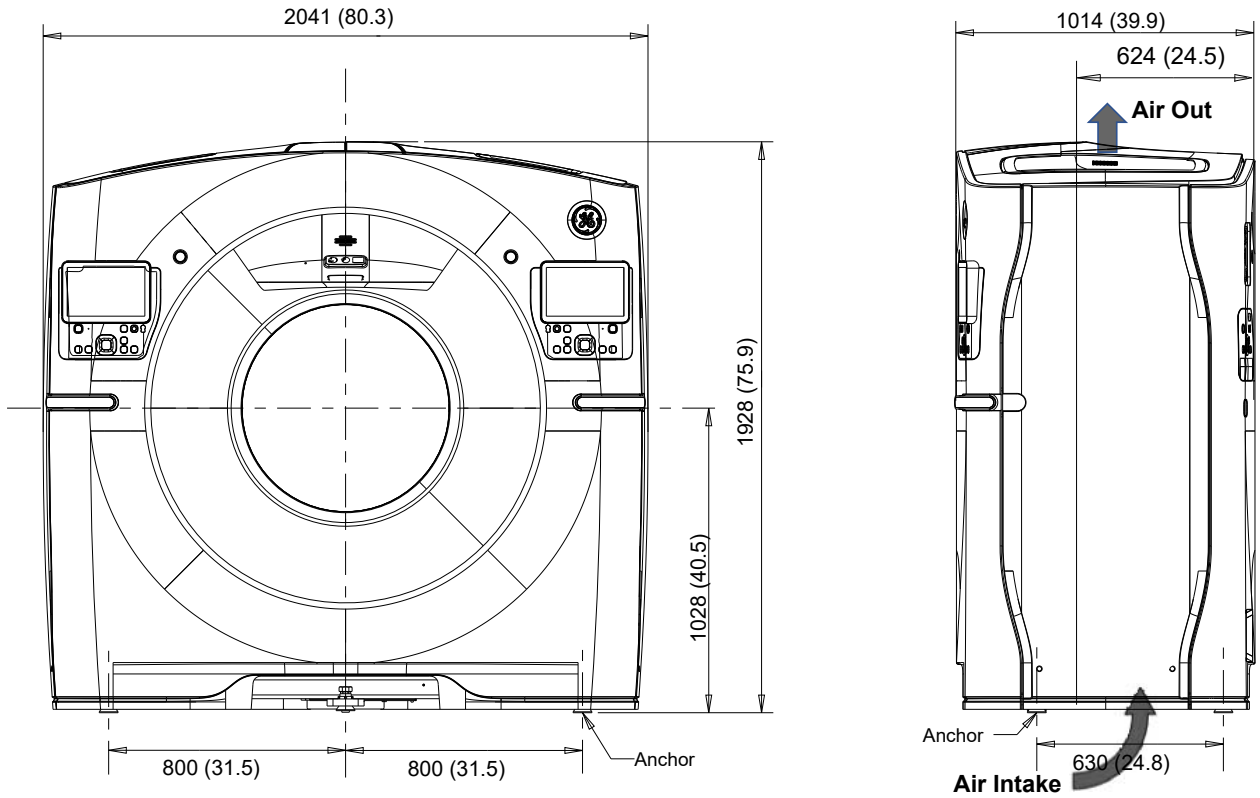

Figure 7-2 Rear Cover Door Full Open

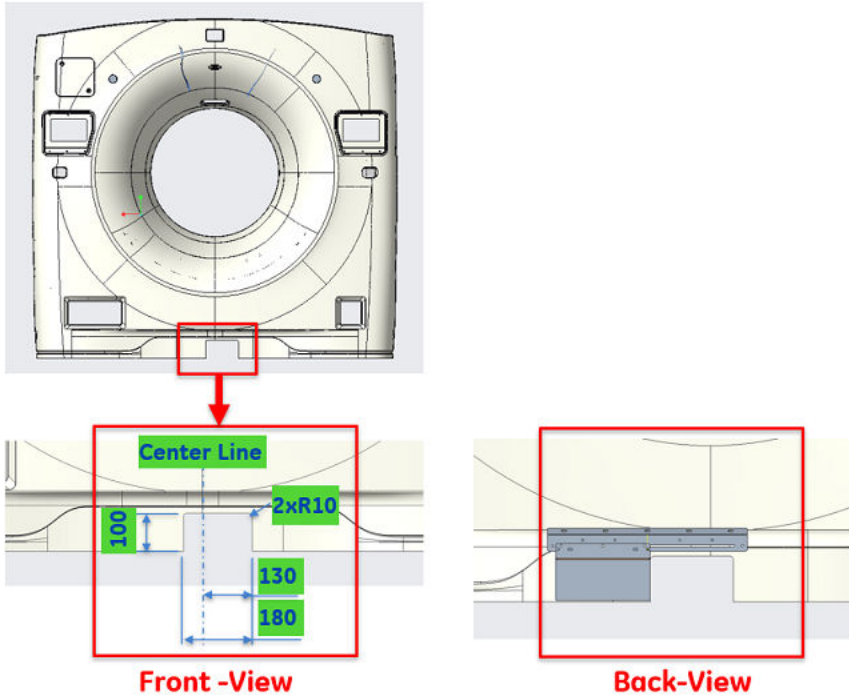
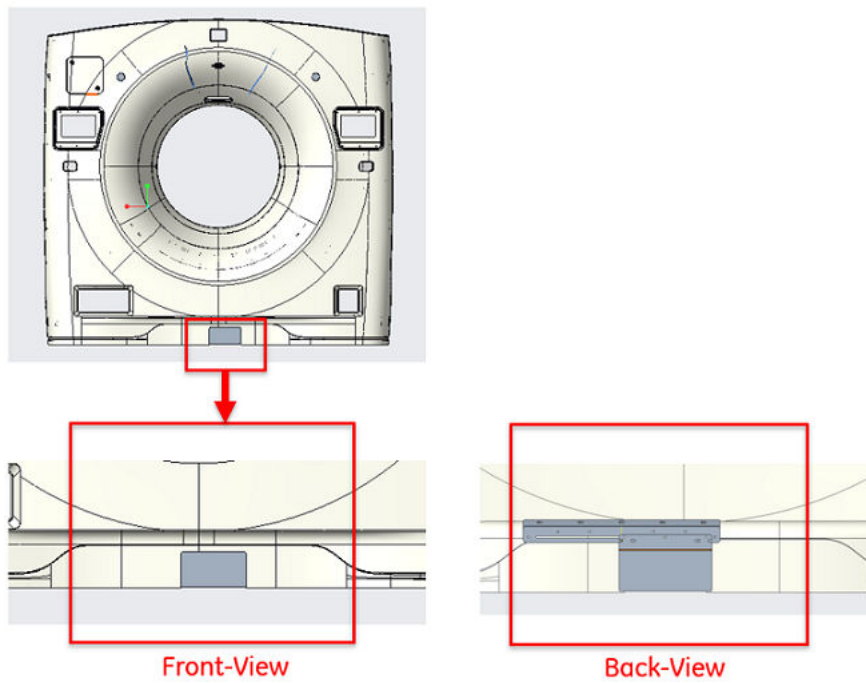
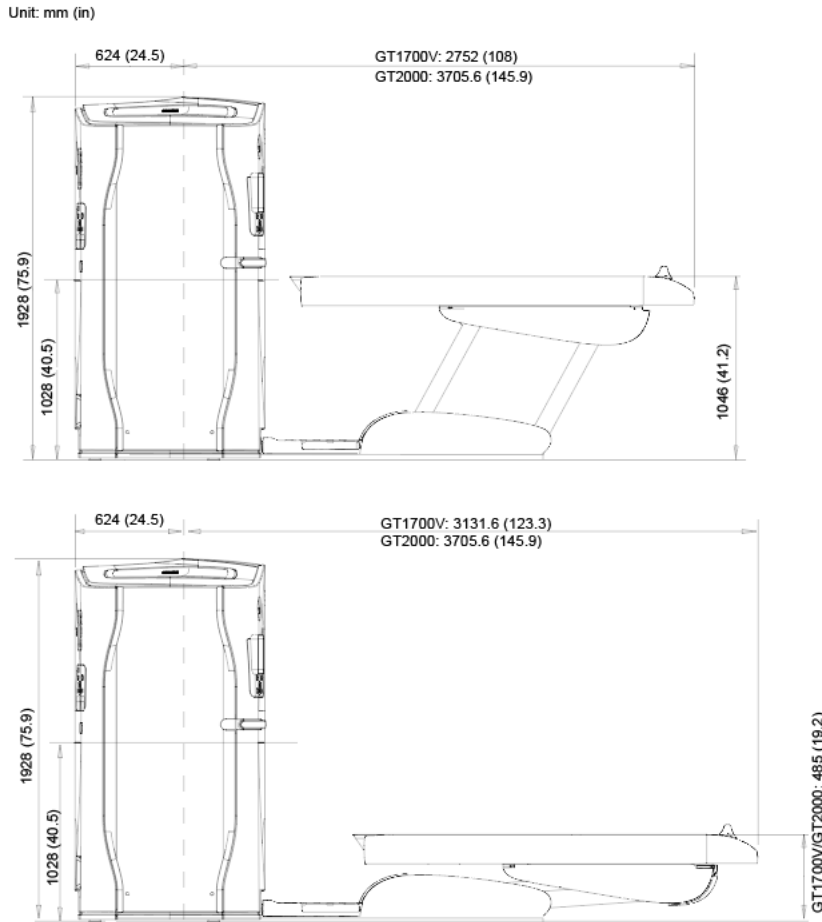

Figure 7-3 Rear Cover Door Full Close



## 7.2.2 Gantry and GT1700V/GT2000 Table Dimensions

Figure 7-4 Gantry and Table Dimensions (Side View)



**NOTE**

Table is located in the highest and the lowest position of electrical limit.

## 7.2.3 Gantry and Lite Table Dimensions

Figure 7-5 Gantry and Table Dimensions (Side View)

Unit: mm (in)

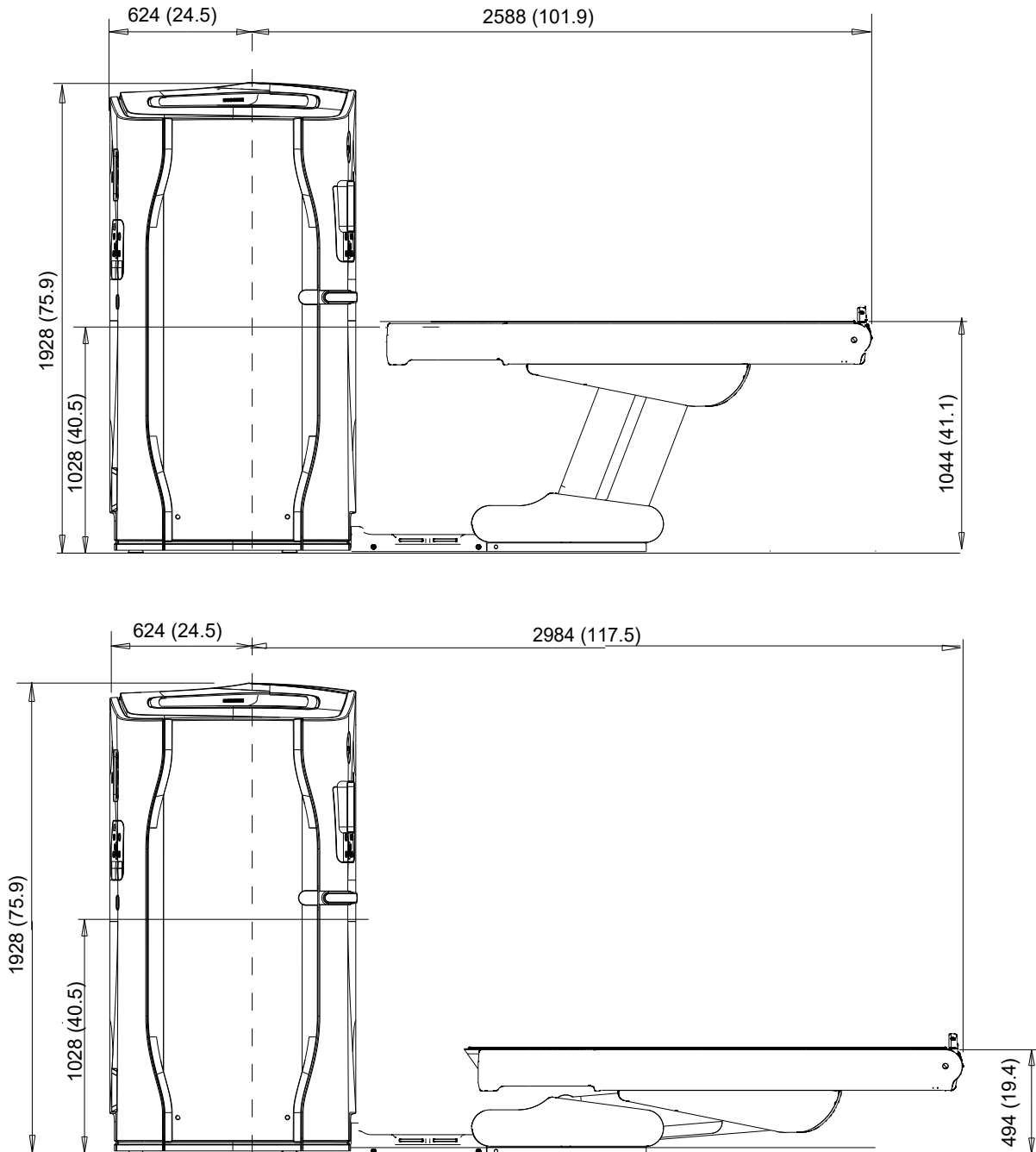

### NOTE

Table is located in the highest and the lowest position of electrical limit.

## 7.2.4 Power Distribution Unit Dimensions

PDU dimensions, air intake/exhaust, seismic bracket locations, and service areas appear below.

**Figure 7-6 Power Distribution Unit**

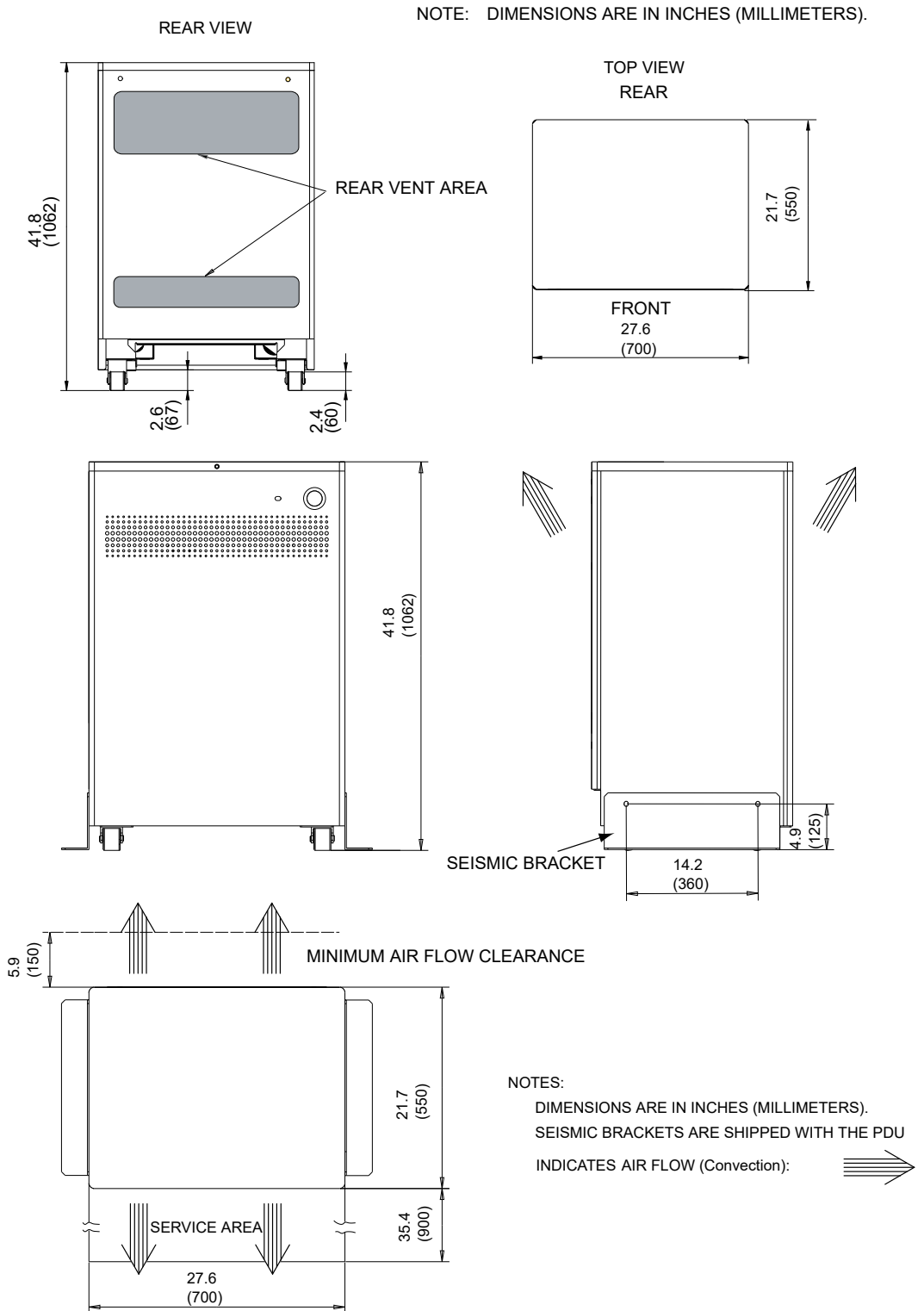

## 7.2.5 Console Dimensions

### 7.2.5.1 Open Console

Figure 7-7 Open Console with Z8G4

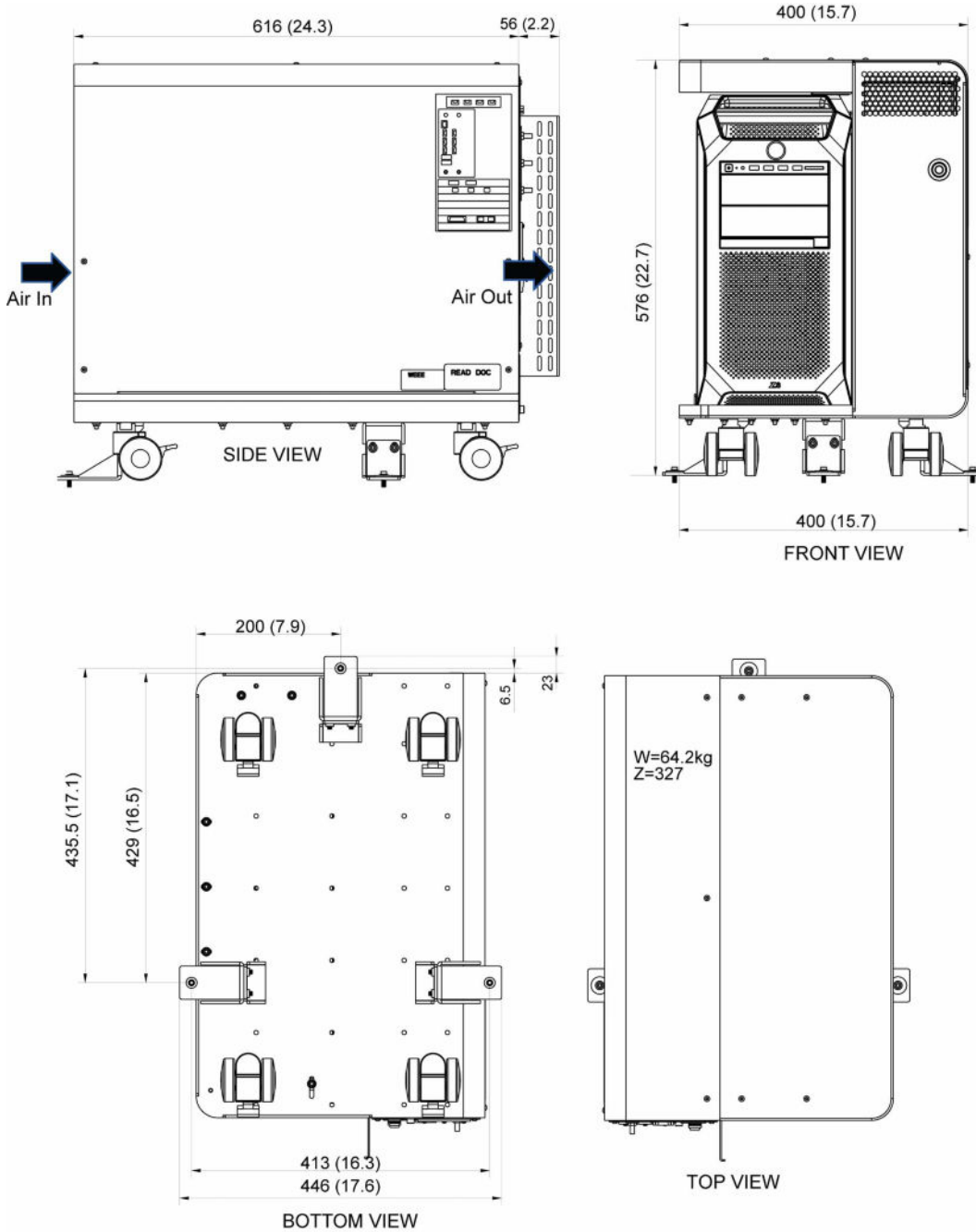

**Figure 7-8 Open Console with Z8G5**

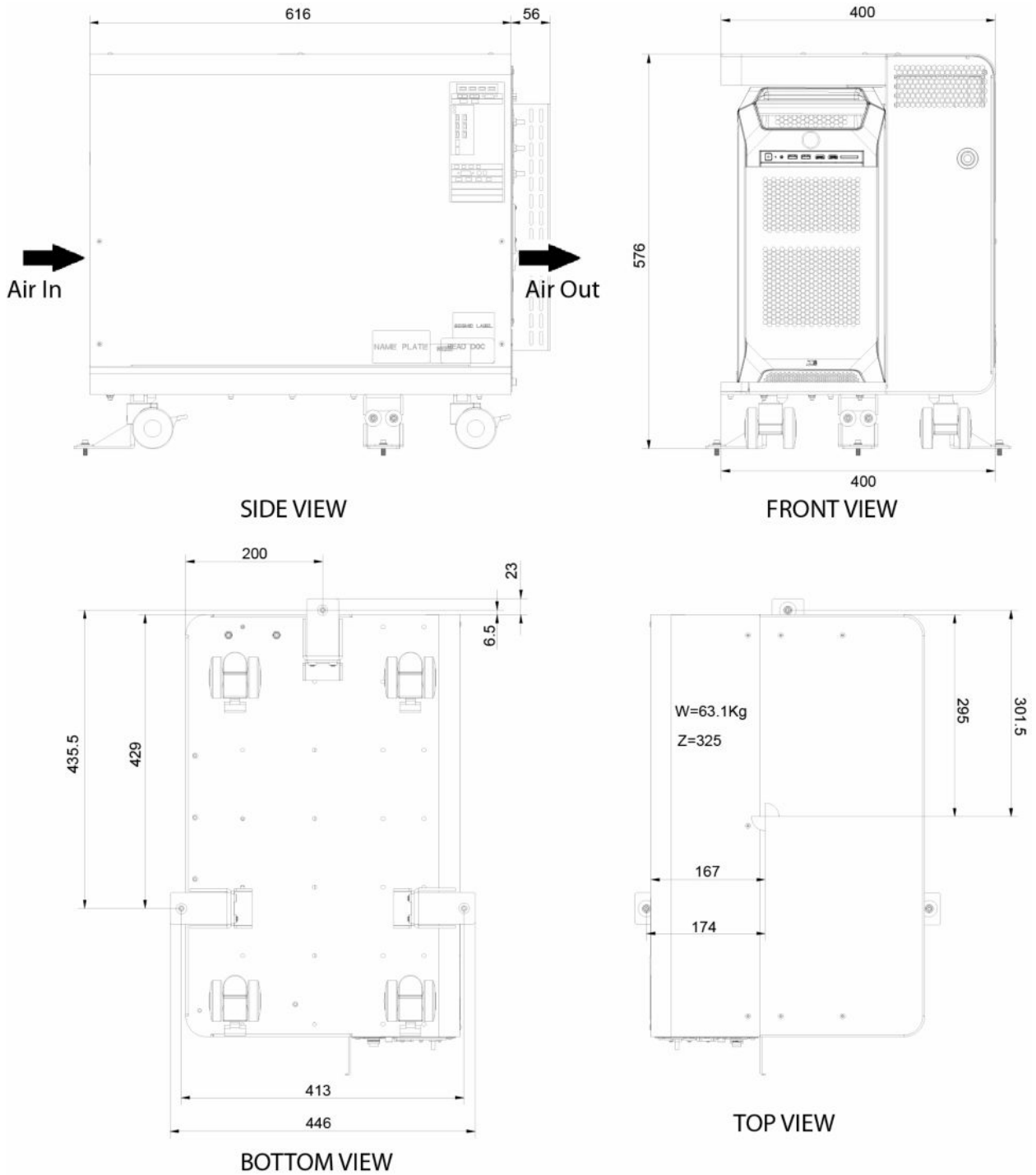

**Table 7-2 Dimensions of Open Console**

Description	Width	Depth	Height	Weight
Open Console with Z8G4	400 mm (15.7 in)	672 mm (26.5 in)	576 mm (22.7 in)	64.2 kg (142lb) (without package) 90.5kg (199.5 lb) (with package)
Open Console with Z8G5	400 mm (15.7 in)	672 mm (26.5 in)	576 mm (22.7 in)	63.1 kg (139lb) (without package) 89.4kg (197 lb) (with package)

## 7.2.5.2 StandAlone Console

Figure 7-9 Z8G4 StandAlone Console



Figure 7-10 Z8G5 StandAlone Console

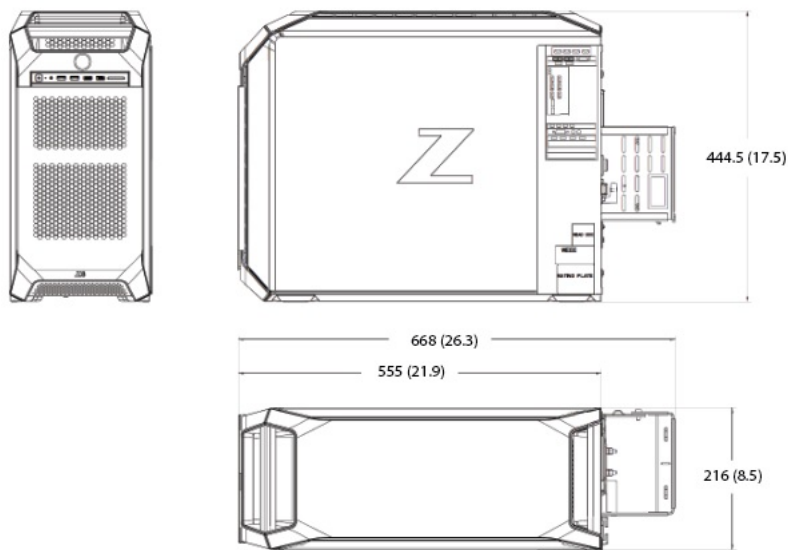

Table 7-3 Dimensions of Host Computer

Description	Width	Depth	Height	Weight
Z8G4 Host Computer	216 mm (8.5 in)	551 mm (21.7 in)	445 mm (17.5 in)	31.7 kg (70 lb) (without package)
Z8G5 Host Computer	216 mm (8.5 in)	555 mm (21.7 in)	445 mm (17.5 in)	23.1 kg (51 lb) (without package)

### 7.2.5.3 Power Box (Option)

Figure 7-11 Power Box

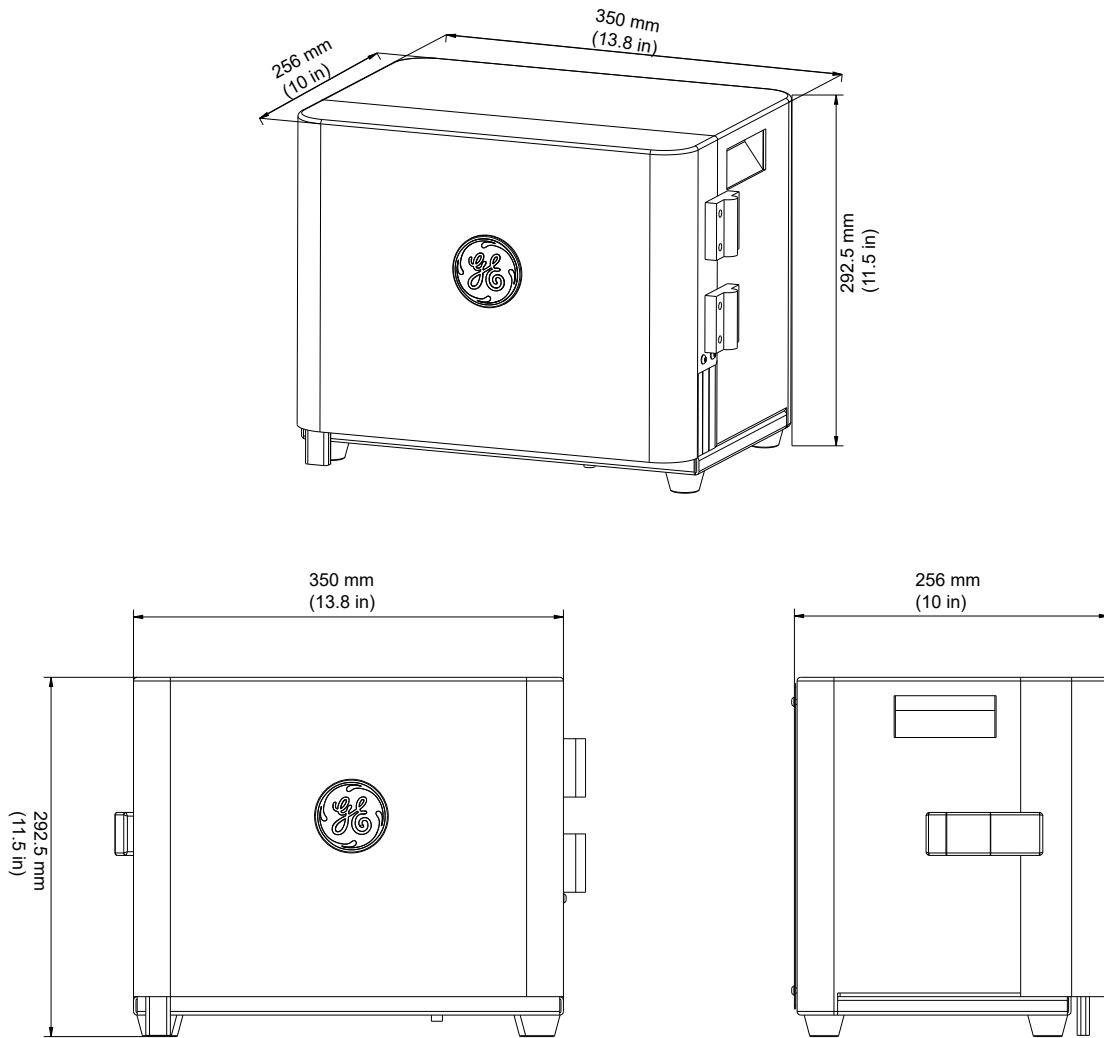

Table 7-4 Dimensions of Power Box

Description	Width	Depth	Height	Weight
Power Box	350 mm (13.8 in)	256 mm (10 in)	292.5 mm (11.5 in)	10.5 kg (23.1 lb)

### 7.2.5.4 Workspace Desk Dimensions

Figure 7-12 Smart Workspace Desk (SWS) (P/N 5449758-2)

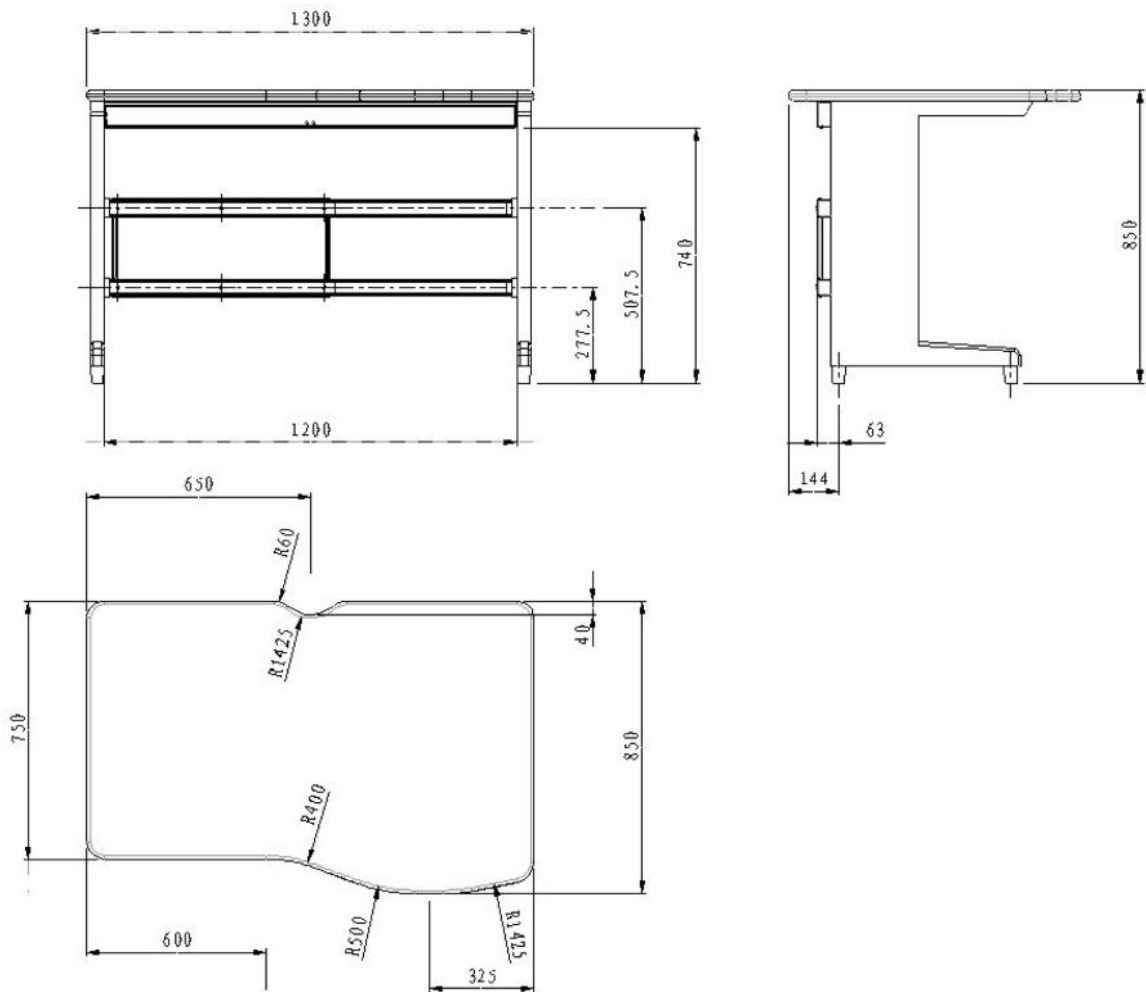

Table 7-5 Dimensions of Smart WorkSpace Desk

Description	Width	Depth	Height	Weight
SWS Desk	1300 mm (51 in)	850 mm (33 in)	850 mm (33 in)	40 kg (88 lb)

## 8 Structural and Mounting Requirements

### 8.1 Importance of Meeting Structural Requirements

System performance specifications require close consideration of the customer's floor properties. The information in this chapter provides critical information and guidelines that the customer or PMI should communicate to the architect, structural engineer, and contractor prior to construction or renovation. Failure to properly evaluate the customer's floor and ceiling properties may result in limited performance and possible safety hazards.

#### 8.1.1 Levelness, Vibration, and Floor Loading

All floors, whether configured to use the recommended GE-supplied anchoring system or an equivalent anchoring method, must meet the system requirements for Levelness, Vibration and Floor Loading.

#### 8.1.2 Seismic Loading

Local laws and building codes in some areas may require the customer's contractor and structural engineer to consider seismic loads. Seismic Mounting provides the information necessary for the customer's contractor and structural engineer to complete the proper seismic calculations.

#### 8.1.3 Anchoring

[8.5 GE-Supplied Anchoring on page 91](#) lists the information necessary for the customer's contractor or structural engineer to properly implement the GE-supplied anchoring system, if appropriate for the site. Please note that local laws, building codes, seismic considerations, and building or structural limitations may require the use of anchoring methods other than the GE-supplied anchoring system. In such cases, responsibility for providing an equivalent anchoring method rests solely with the customer's contractor or structural engineer.

Consult your architect, structural engineer, contractor, or PMI to resolve any questions.

#### **NOTICE**

Responsibility for providing an approved support structure and mounting method for all floor types, other than those listed in this chapter, rests with the purchaser. General Electric accepts no responsibility for any failure of the support structure or anchoring method, including seismic mounting and anchoring. GE accepts no responsibility for methods other than those listed.

## 8.2 Ceiling Requirements

## 8.2.1 Regulatory Requirements

For systems with Suspension Options (Boom-in-Room or Depth Camera etc...), the overhead suspension shall be installed by strictly following the GEMS installation instruction. The system manufacturer specifically disclaims any and all liability arising out of or relating to the use or performance of the suspension (including cables), including, without limitation, any liability or claims relating to patient injury, death, or the reliability of such suspension.

Where a Junction Plate is supplied and installed by the Purchaser of the system, the installation plate should comply with the applicable Regulation enforced in the country.



The customer's architect is responsible for designing and installing of all junction plates for ceiling mounted components. The system manufacturer will NOT inspect and test that the junction plate meets the loading capacity specified (recommend a 6x safety factor).

## 8.2.2 Ceiling Requirement for Boom-In-Room

If customer has purchased Boom-In-Room kit, please refer to the correct option manual for details.

The minimum ceiling height above the table and gantry shall measure at least 2286 mm (90 in.) or the minimum distance allowed by local laws and codes, whichever is greater, when measured from the floor to the finished ceiling or to the ceiling pedestal mounts of any ceiling-mounted components. The purchaser or their contractor shall complete the installation of all pedestals for ceiling-mounted components. The PMI will provide the necessary bolt hole information upon request.

The support structure for a ceiling-mounted option using a Mavig pedestal, requires a flush ceiling mounting plate. This flush ceiling mounting plate must be designed by a structural engineer and installed by a qualified contractor prior to the system installation.



### NOTE

A finished ceiling is required.

### 8.2.2.1 Ceiling Mounted Devices

If a ceiling mounted injector, remote monitor or other device is installed, it should be mounted in a position that allows for adequate patient and site personnel access to the table and gantry. It should not obstruct access to the gantry operator controls or interfere with patient loading. Refer to the table entitled Minimum Dimensions and Operational Clearances in System Component Dimensions chapter for minimum clearance requirements between the lowest points of the fixed ceiling mounted device and finished floor. The installation of any ceiling mounted device not specifically installed by GE Healthcare personnel shall be completed by the purchaser of their contractor. The GE Healthcare Project Manager will provide the necessary bolt hole information upon request.



### NOTE

If a ceiling mounted boom-in-room monitor, it should NOT be mounted another arm with equipment (like injector etc..) on the same pedestal ceiling.

### 8.2.2.2 Boom Installation Typical Layout

**⚠ WARNING**



The ceiling-mounted components should NOT touch any electricity conductive structures which are connected with power or grounding other than CT system's power and grounding, to avoid unexpected short circuit/arcing hazard.

**Figure 8-1 Boom-In-Room Cables Routing - Receiver + Optical Fiber 5573673**

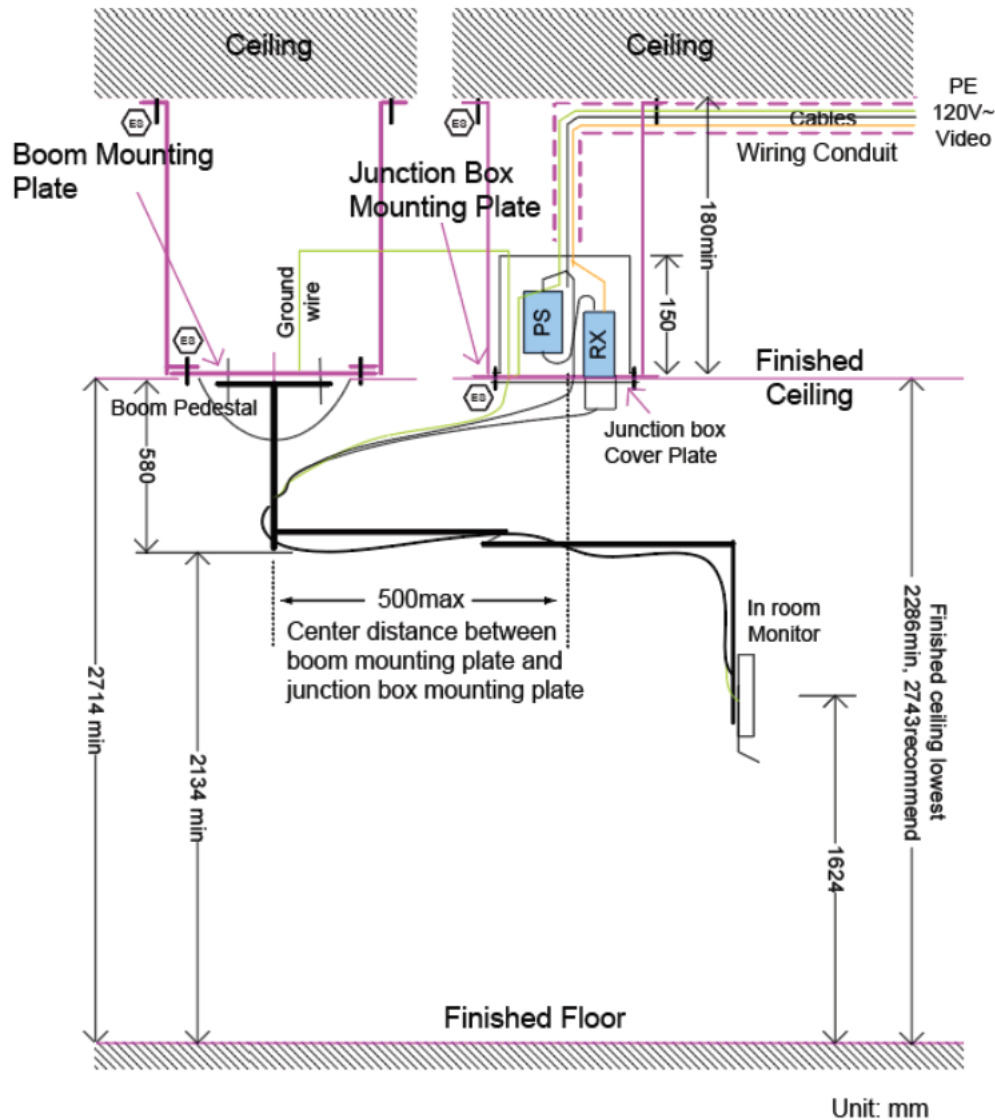

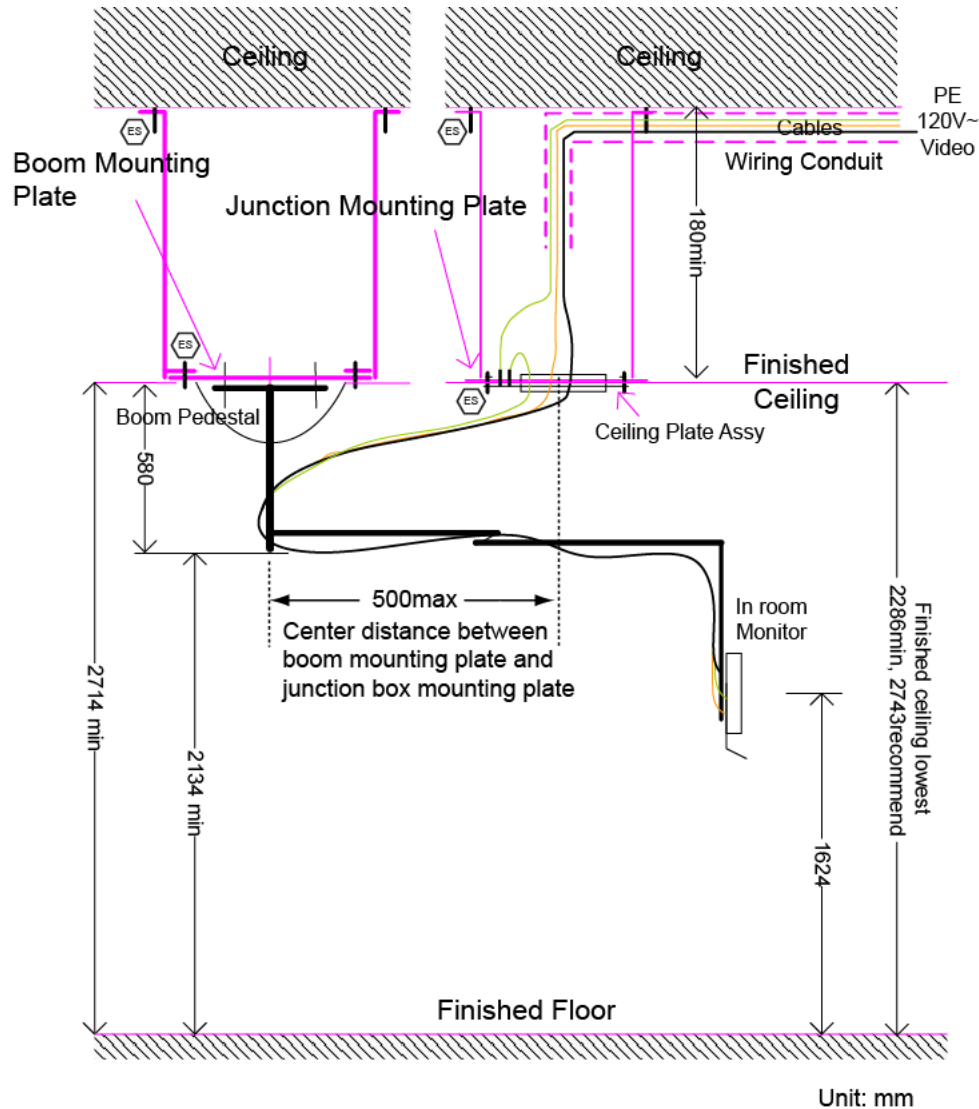
**Figure 8-2 Boom-In-Room Cables Routing - DVI Hybrid-Active Fiber 5830535**

### 8.2.2.3 Pedestal Mounting Plate (Supplied by Customer)

The pedestal ceiling mount requires a flush ceiling mounting plate that is structurally supported to handle the weight of the load as shown in [Figure 8-3 Center of Gravity for Boom-In-Room Kits, shown on the site print on page 61](#).

There are two types of ceiling column, suspension arms, and LCD mast/handle in B7710AN (5115174-20).

Some options may require different option plates than those listed below. Refer to the options install manual to determine which plate is required.

**Figure 8-3 Center of Gravity for Boom-In-Room Kits, shown on the site print**

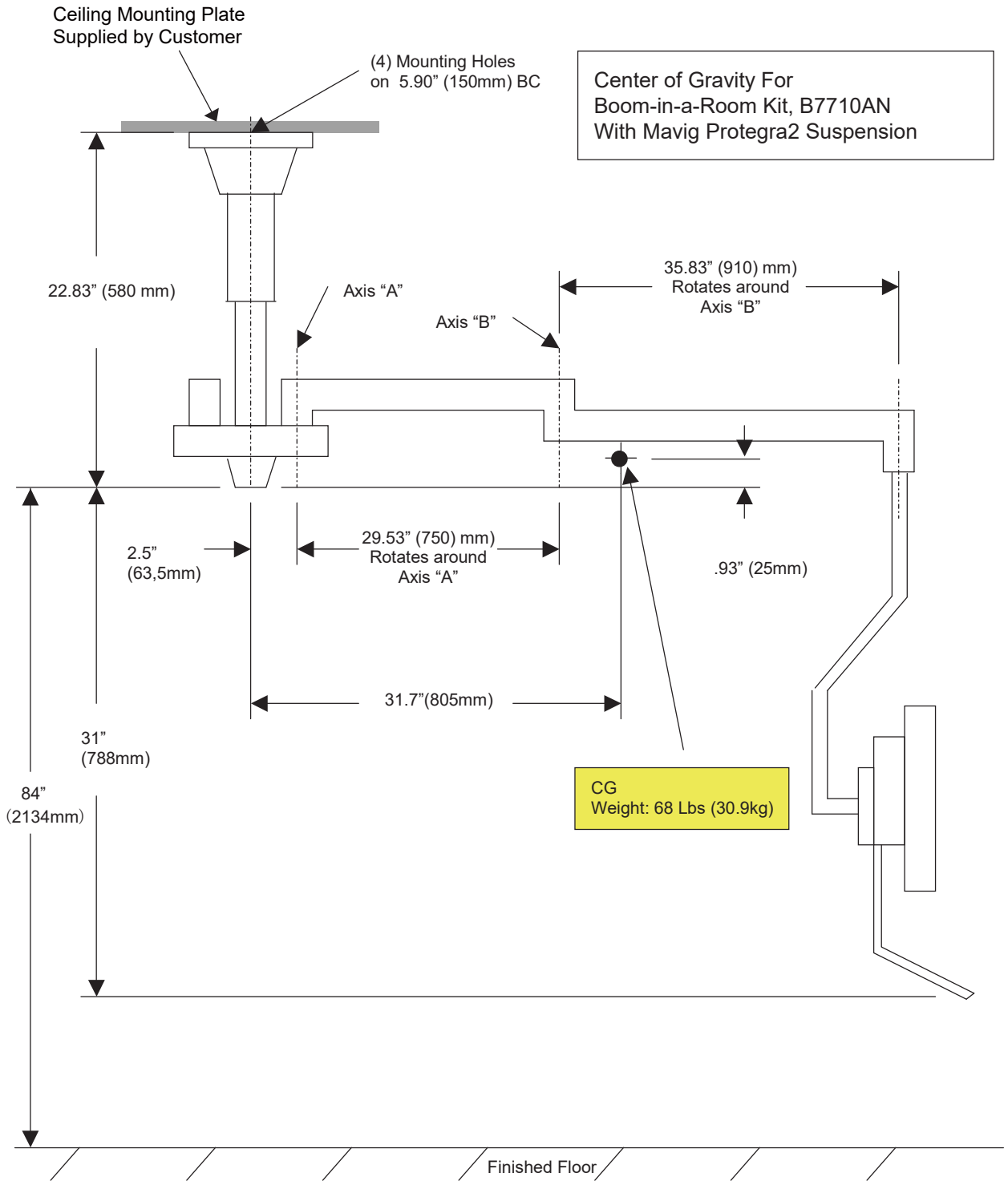

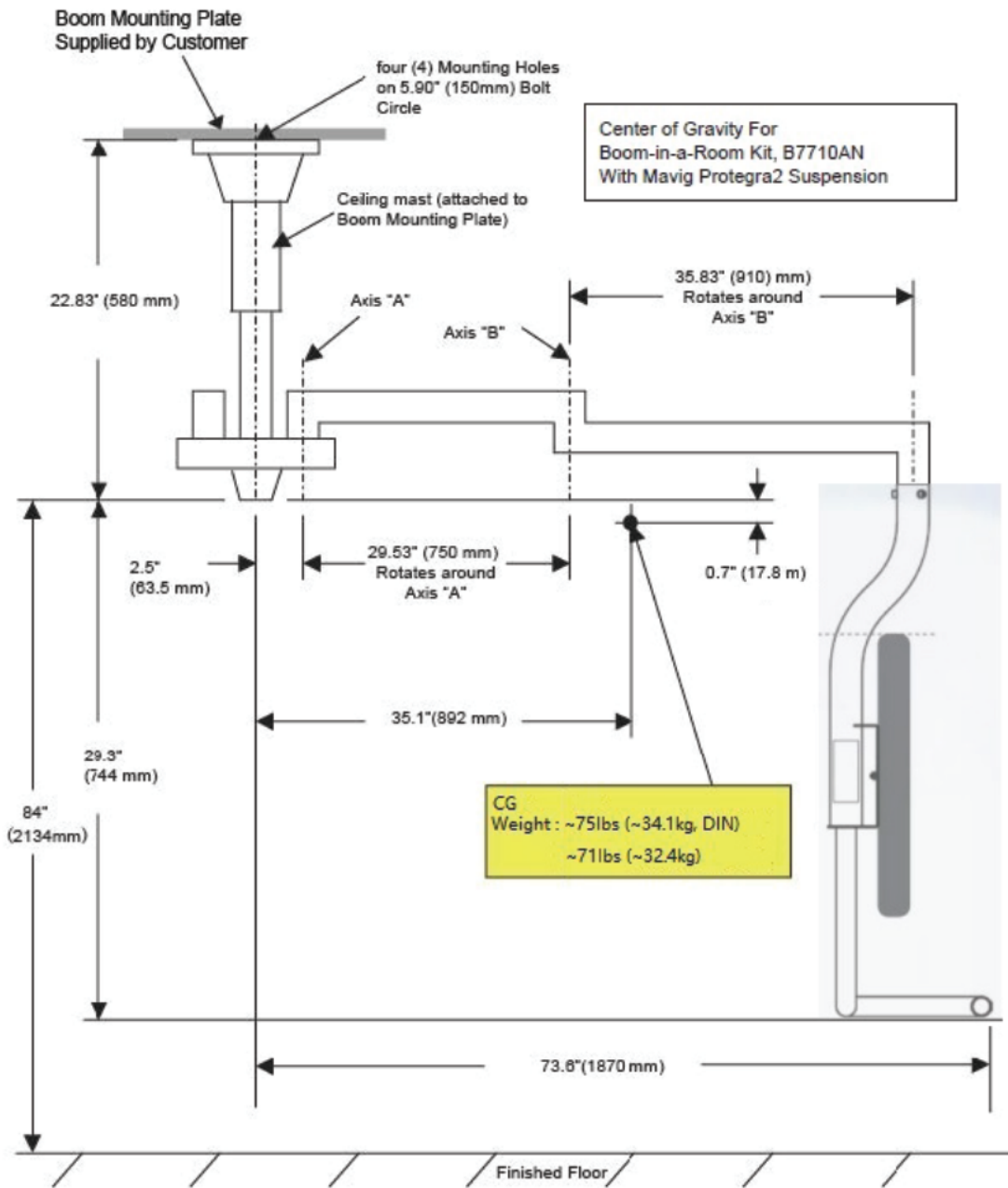

If a structural contractor designed an equivalent plate, four (4)  $\Phi 14$  (0.55 in.) mounting holes are required to anchor the boom pedestal (with flat washer, lock washer and hex nut) to the boom mounting plate and one M8 (0.32 in.) hole is used to anchor the safety chain bracket assembly. One  $\Phi 15$  (0.59 in.) hole is used for the ground cable connection.

Detailed instruction for hole size and a template is available from Mavig or in their Portegra Installation Manual. Refer to [Figure 8-4 Mounting Hole Pattern for Pedestal Mounting Plate](#) on page 63.



## 8.2.2.5 Junction (Box) Mounting Plate

Figure 8-5 Junction Mounting Plate Dimension

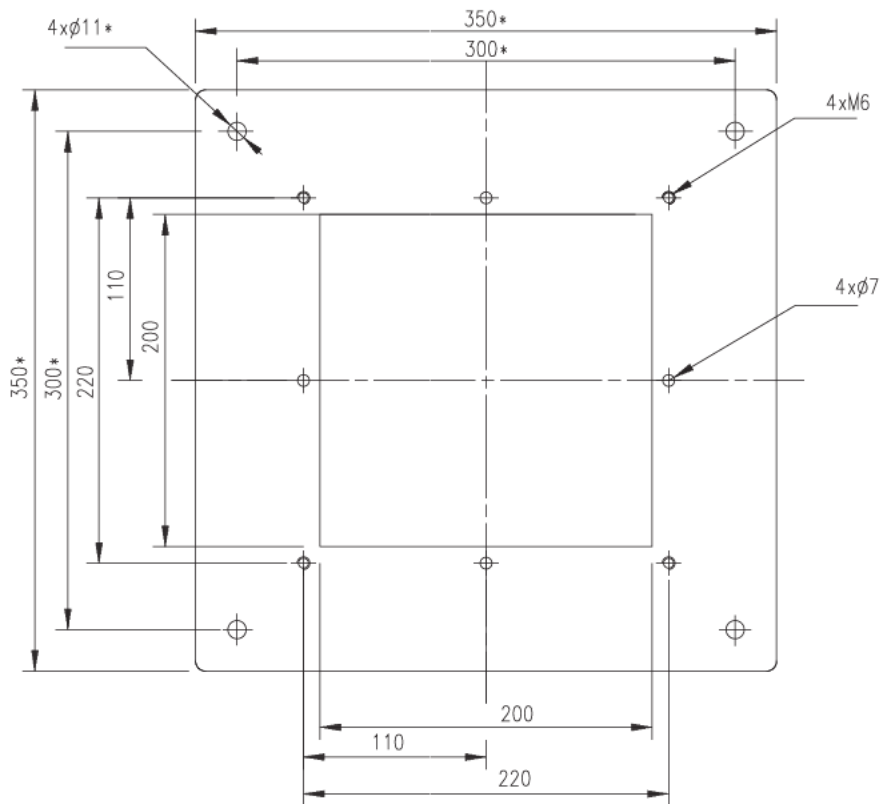

THE DIMENSIONS WITH \* IS ONLY FOR CUSTERMOER REFERENCE



### NOTE

Dimensions marked with an asterisk (\*) above (and the available engineering drawing provided by the PMI) are for customer reference only. Since the customer supplies this plate, dimensions marked with (\*) are minimum size recommendations and may vary, depending on customer ceiling layout.

- With Junction Box

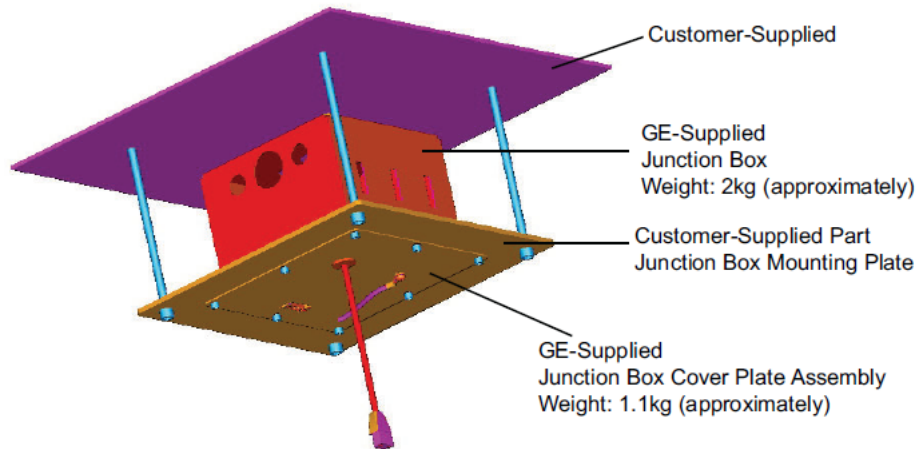
**Figure 8-6 Junction Box Mounting/Ceiling Plate**

- Without Junction Box

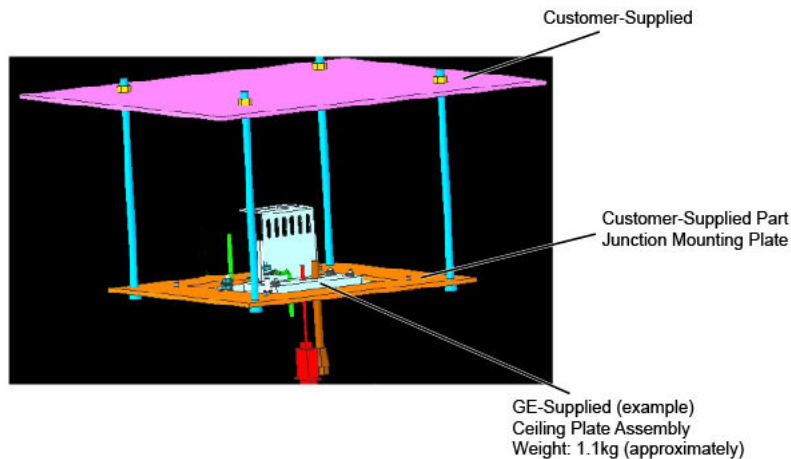
**Figure 8-7 Junction Mounting Plate/Ceiling Plate Assy**

### 8.2.3 Ceiling Requirement for Auto Patient Positioning Depth Camera

If customer has purchased Express Mode Depth Camera Option, please refer to **Auto Patient Positioning Depth Camera Installation Manual (5809939-1EN)** from SIMS Content Viewer for details.

#### **NOTICE**

NOTE TO SITE PLANNING AND CUSTOMERS:

Though the camera coverage is defined at 100mm above isocenter, Auto Patient Positioning works at different table heights, with variable patient sizes. The technique works even if part of the patient body being scanned is out of the camera view or the patient body occupies only a smaller portion of the view, but the best accuracy is achieved when the full patient body fits the view. Appropriately choosing the desired camera coverage before camera installation can optimize the Auto Patient Positioning performance.

**Figure 8-8 Boom-In-Room Moving Radius**

Cables fixed position (Junction Box)

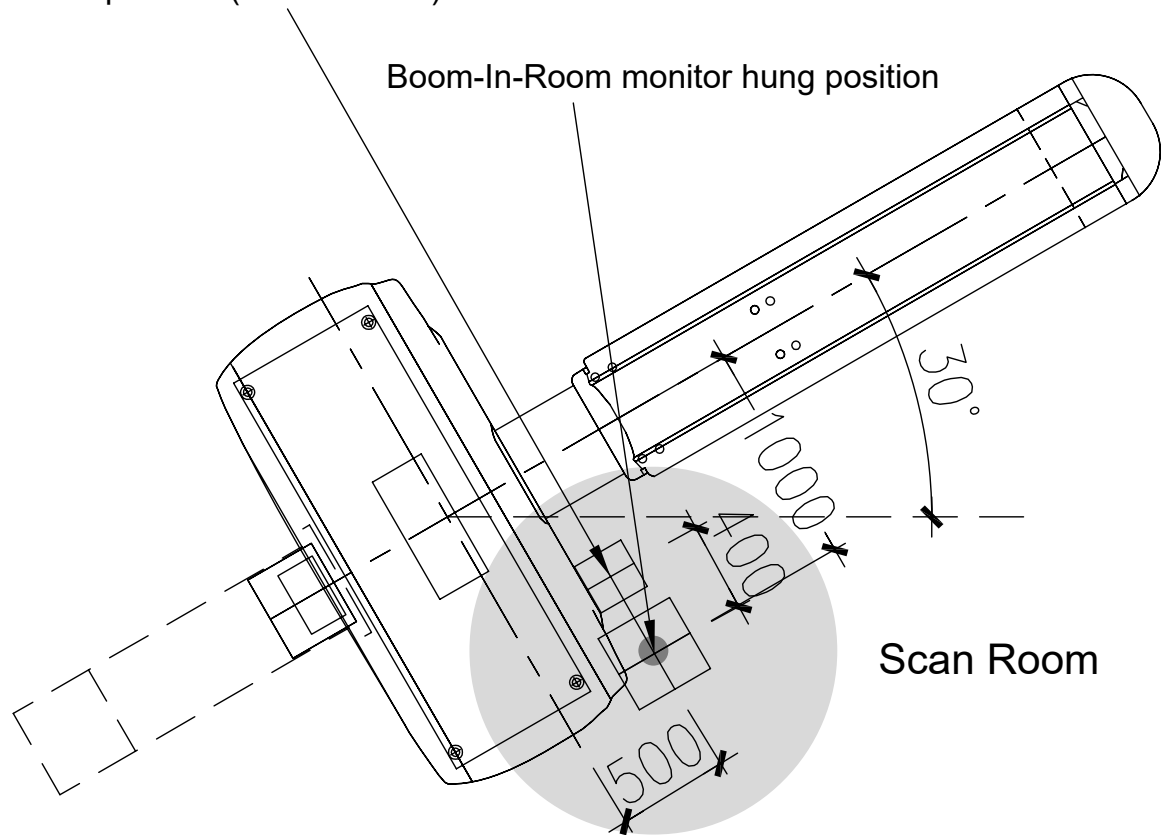
**CAUTION**

When moving ceiling mounting devices (In-Room-Monitor, Injector, Anesthesia Machine etc), make sure to avoid damage to the depth camera resulted from collisions by the suspension arms.

**NOTICE****NOTE FOR COLLISION AVOIDANCE WITH IN-ROOM-MONITOR:**

When determining the camera installation position, it's also important to avoid possible collision with the Boom-in-Room. The "upper arm" of the boom can reach a range of 850mm radius.

The camera shall be installed:

- either outside of this 850mm-radius range (the camera cover size is 360 (W)x360 (L)x180 (H) mm<sup>3</sup>).

or

- inside the range but its bottom cover is higher than the Boom upper arm. Mavig recommends no less than 579mm from finished ceiling to the column bottom. This is equivalent to 380mm between finished ceiling and the upper arm.

If the camera is installed within the boom arm reach, the customer shall be suggested to install a protective bracket beside the camera or the boom arm to avoid damage of the camera.

### 8.2.3.1 Depth Camera Installation Typical Layout

**NOTE**

The USB (5809034-3) is plenum rated, no conduit is required. However is customer chooses to run conduit it should be 20mm is size.

**Figure 8-9 Room Layout**

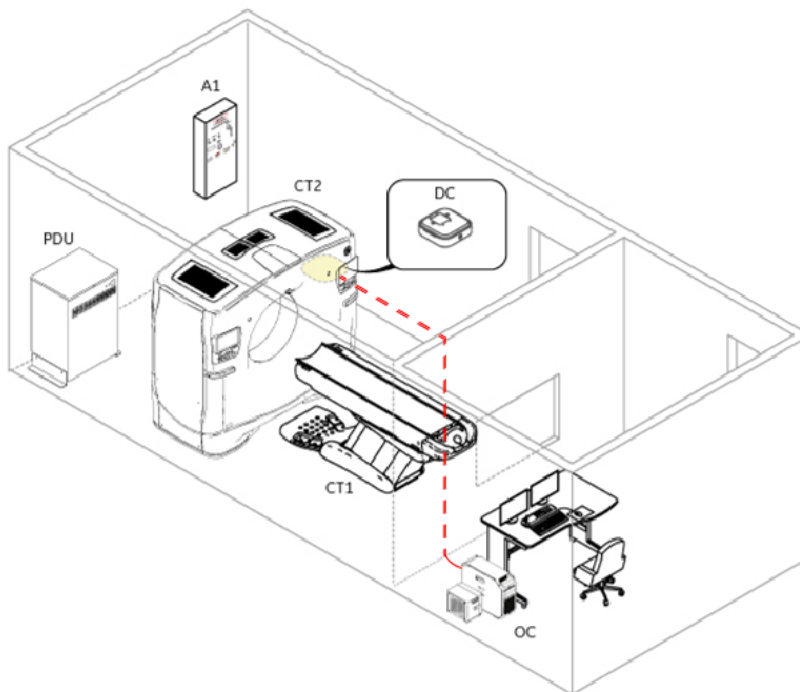

----- Depth Camera cable routing from Operator Room to Scan Room

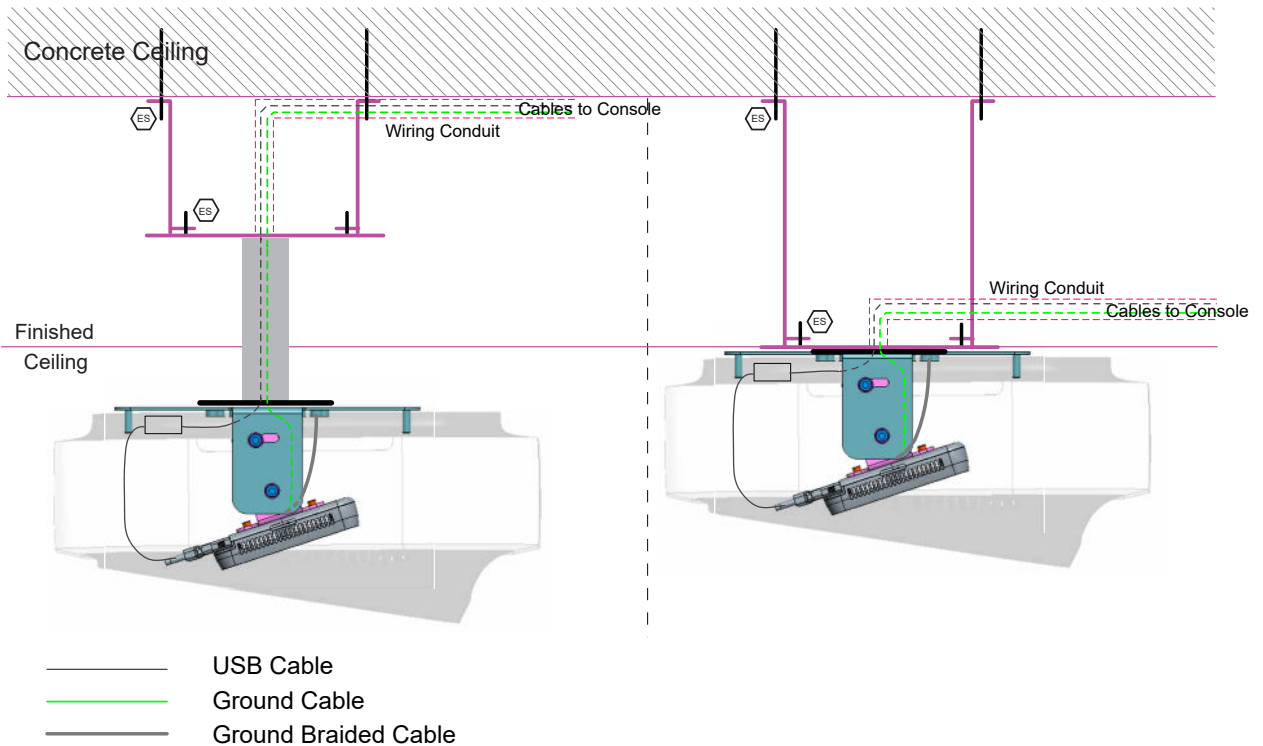
**Figure 8-10 Camera Cables Routing****WARNING**

The ceiling-mounted components should NOT touch any electricity conductive structures which are connected with power or grounding other than CT system's power and grounding, to avoid unexpected short circuit/arcing hazard.

**8.2.3.2 Junction Plate Requirement**

GE will provide a Junction Plate (5847942-2), shipped with the depth camera assy kit (5808502). If the Junction Plate supplied by GE can not meet the requests of the customer or the building structure, the customer's architect can design and install the Junction Plate (refer to Prepared by Customer) with sufficient strength to hold the camera assembly.

**NOTICE**

No matter customer uses GE junction plate or makes junction plate by themselves, customer is responsible for installing it on the concrete ceiling and meeting regulatory and GE's loading requirement.

### 8.2.3.2.1 Supplied by GE

**WARNING**



ES

The system manufacturer will NOT inspect and test that the fixing methods between the Junction Plate and the building structure meet the loading capacity specified (recommend a >4x safety factor), which is the customer's responsibility.

**Figure 8-11 Example for Fixing Junction Plate by using Anchor Bolts**

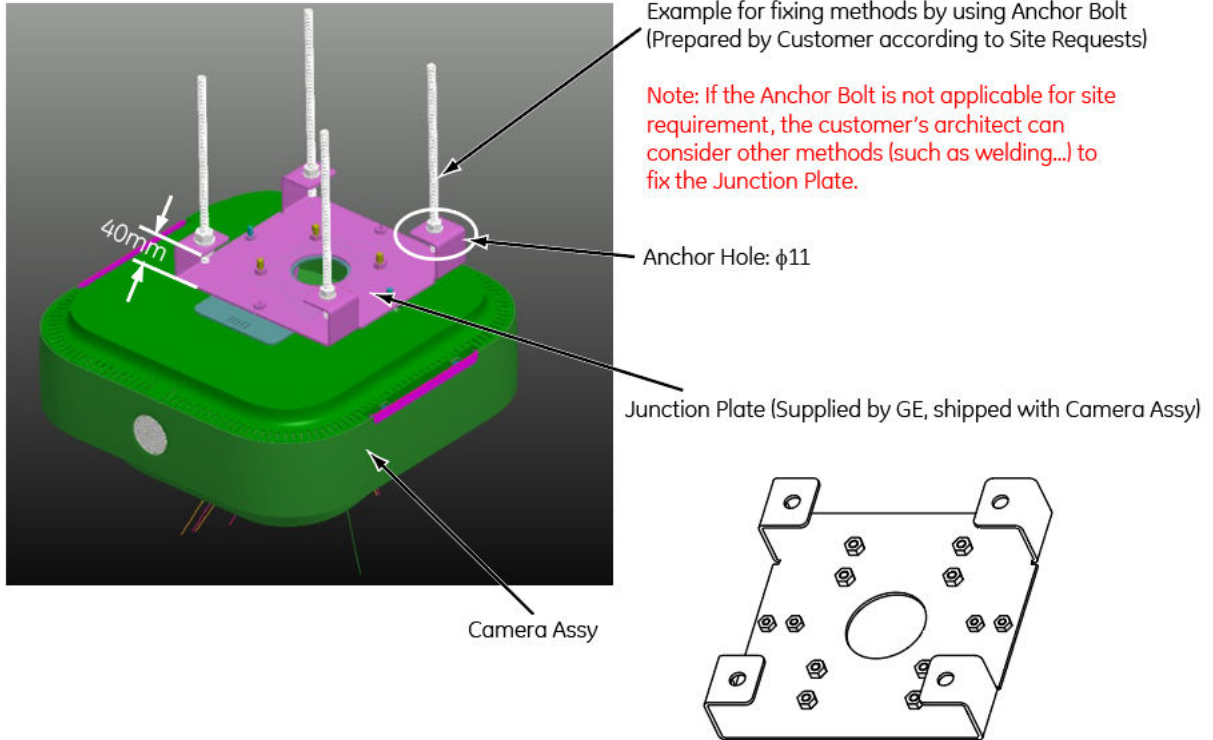

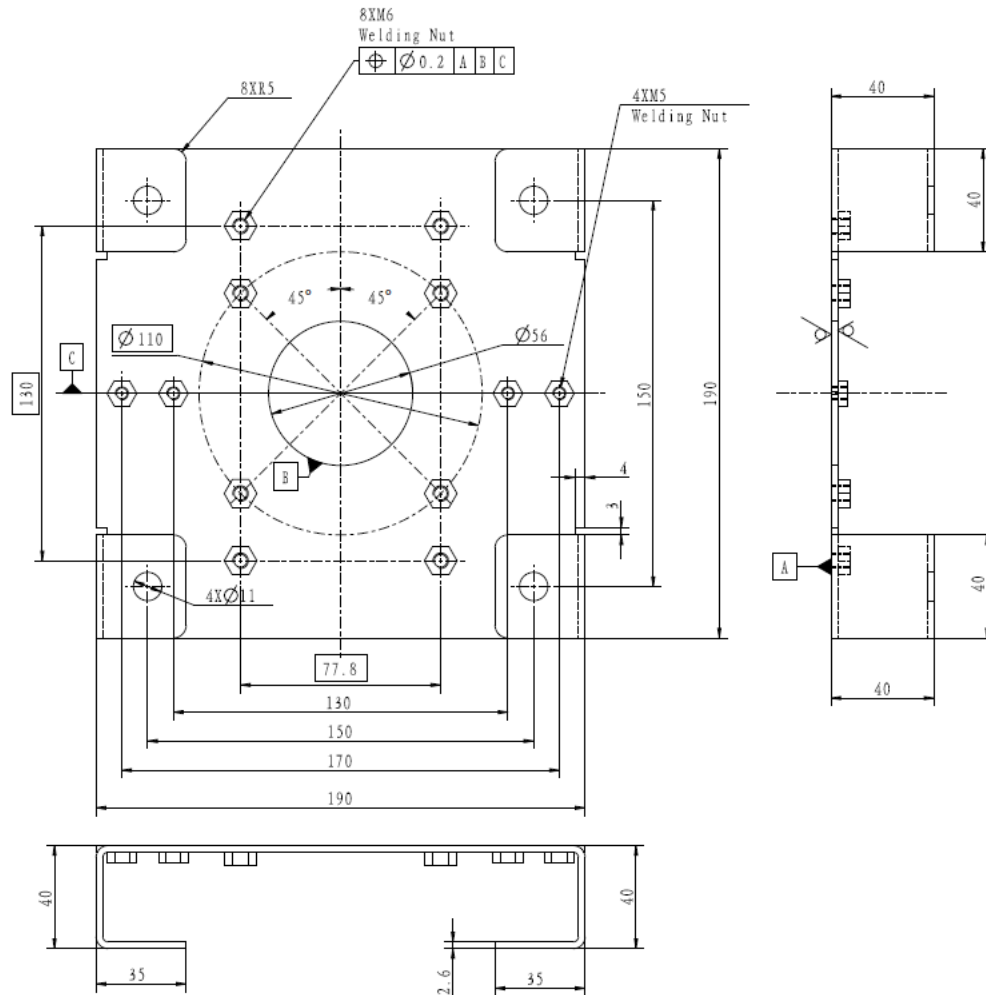
**Figure 8-12 Junction Plate (Supplied by GE)****8.2.3.2.2 Prepared by Customer****⚠ WARNING**

The customer's architect is responsible for designing and installing the Junction Plate with sufficient strength to hold the Camera Assembly. The weight of the camera assembly is approximately 3.75kg, suggest the safety load on the Junction Plate is no less than 20kg.

**⚠ WARNING**

The system manufacturer will NOT inspect and test that the Junction Plate meets the loading capacity specified (recommend a >4x safety factor), this is the customer's responsibility.

**Figure 8-13 Junction Plate (Prepared by Customer)**

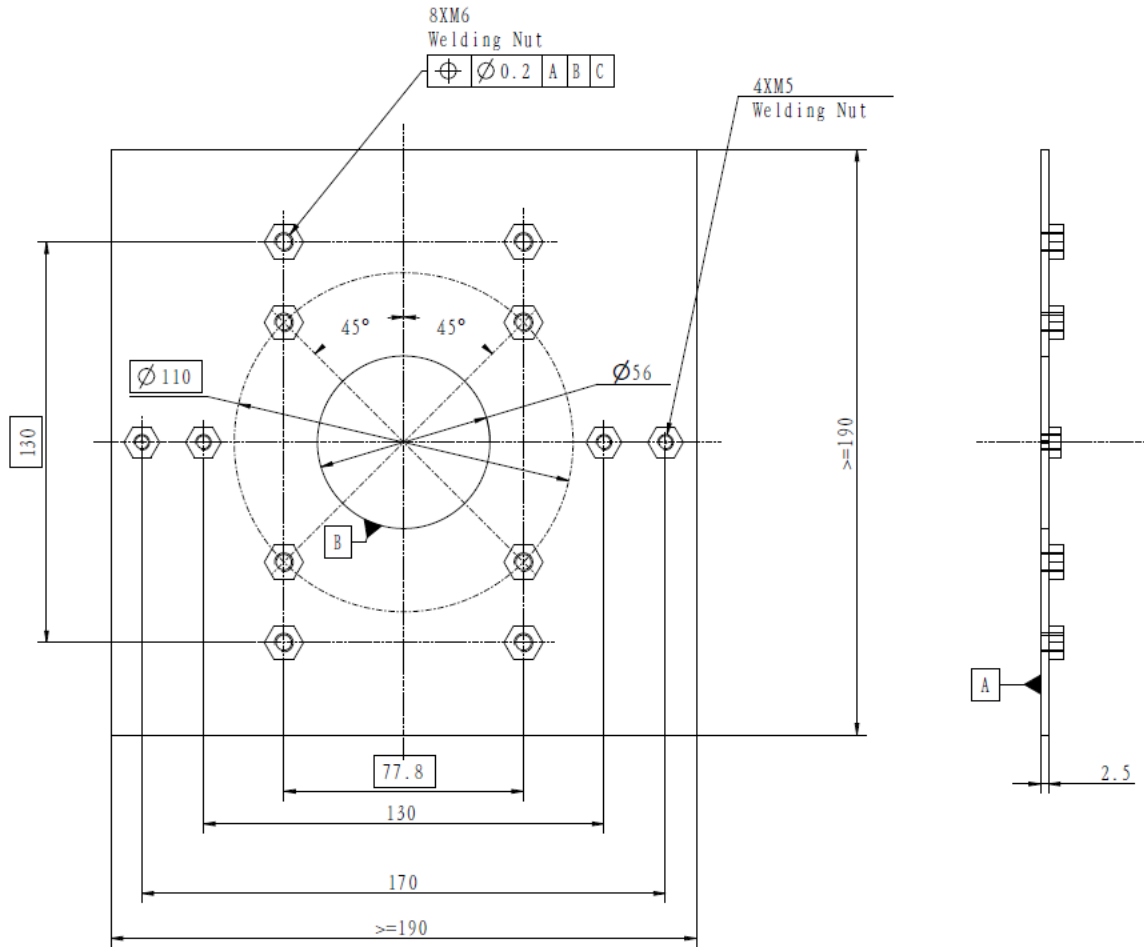

**Table 8-1 Junction Plate (Prepared by Customer)**

GB-T 13681-1992 Welding Nut		
	M5	M6
Thickness (mm)	3.7-4	4.7-5
Pledge Load (N)	11000	15500
Pledge Load (N) is to insure welding nut on junction plate is firmly enough. The junction plate already shipped together with express mode, if customer want to build junction plate by themselves, then they need to meet our 6x load requirement (>=20kg).		
Junction plate material: Steel material with a min tensile strength 375Mpa.		

**8.2.3.2.3 Junction Plate Installation Direction**

**NOTICE**

The Junction Plate direction should be in line with the system layout, NOT be in line with the scan room. see below figure for example of the Junction Plate direction.

**Figure 8-14 Junction Plate Installation Position**

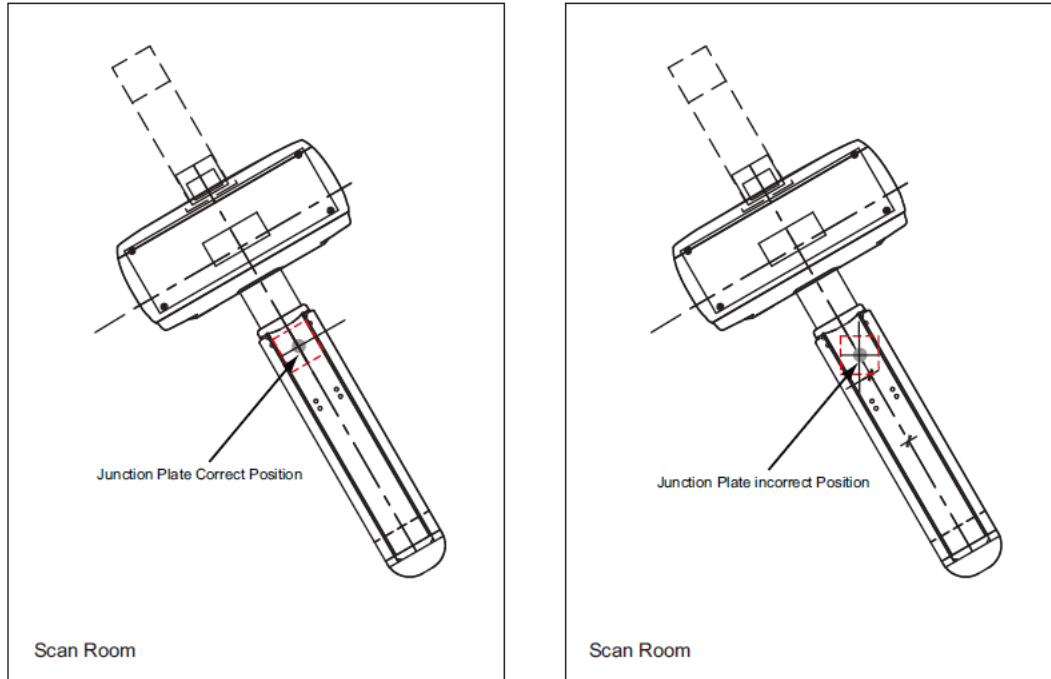

**Figure 8-15 Junction Plate Installation Direction**

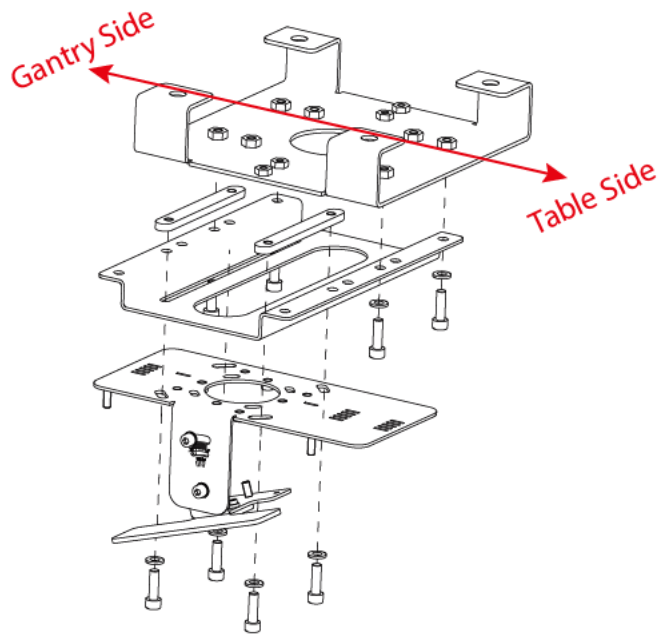

### 8.2.3.3 Junction Plate Position

When determining the camera installation position, special consideration shall be paid to the relation between the junction plate installation height and the finished ceiling height.

For the detailed procedure, please refer to **Auto Patient Positioning Depth Camera Installation Manual (5809939-1EN)**.

There are three cases for the Junction Plate installation as shown below:

- **Case A: Camera below finished ceiling**

Camera installation height is less than the finished ceiling height, customer needs order the extender kit (5821337) to install the Junction Plate 200mm or 400mm above the desired position.

**Figure 8-16 Camera Installation Position\_A**

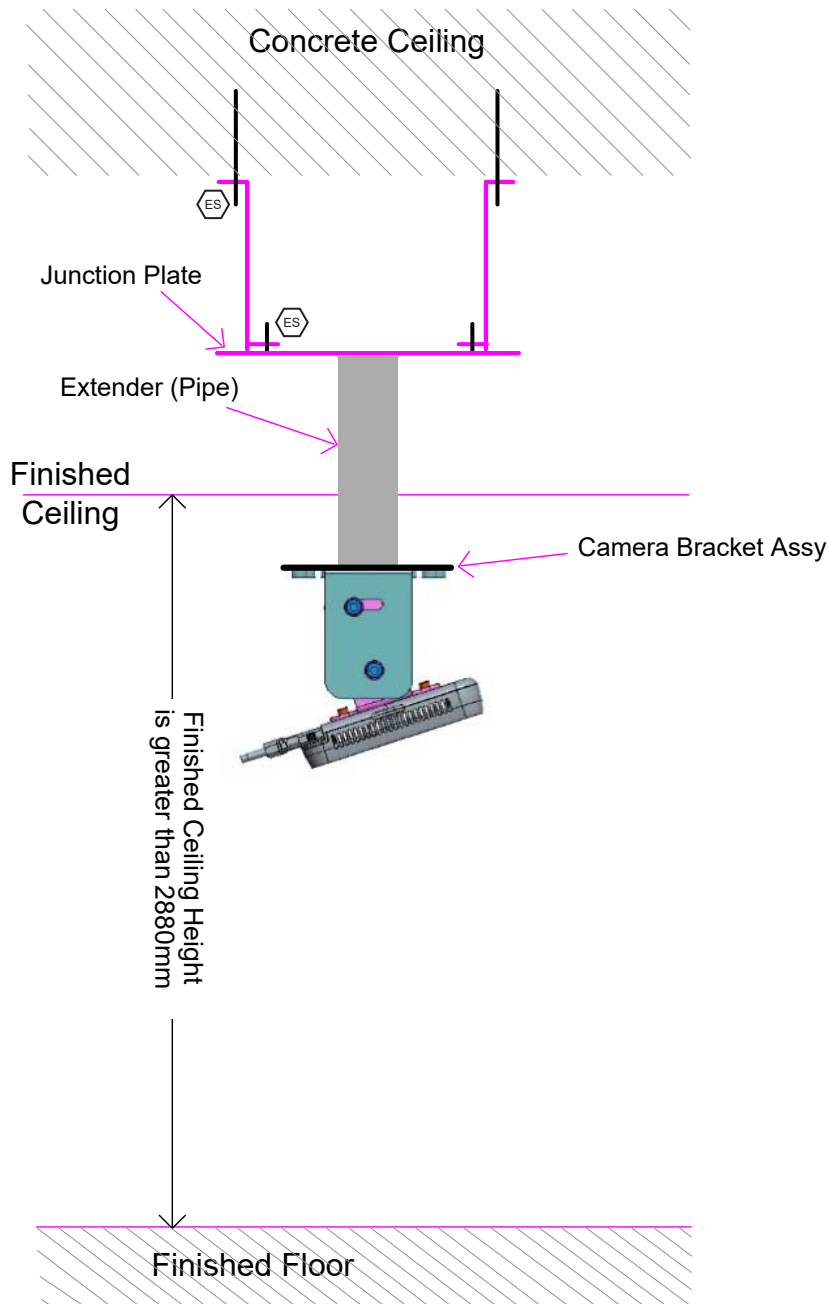

- **Case B: Camera attached to finished ceiling**

Camera installation height is equal to the finished ceiling height.

**Figure 8-17 Camera Installation Position\_B**

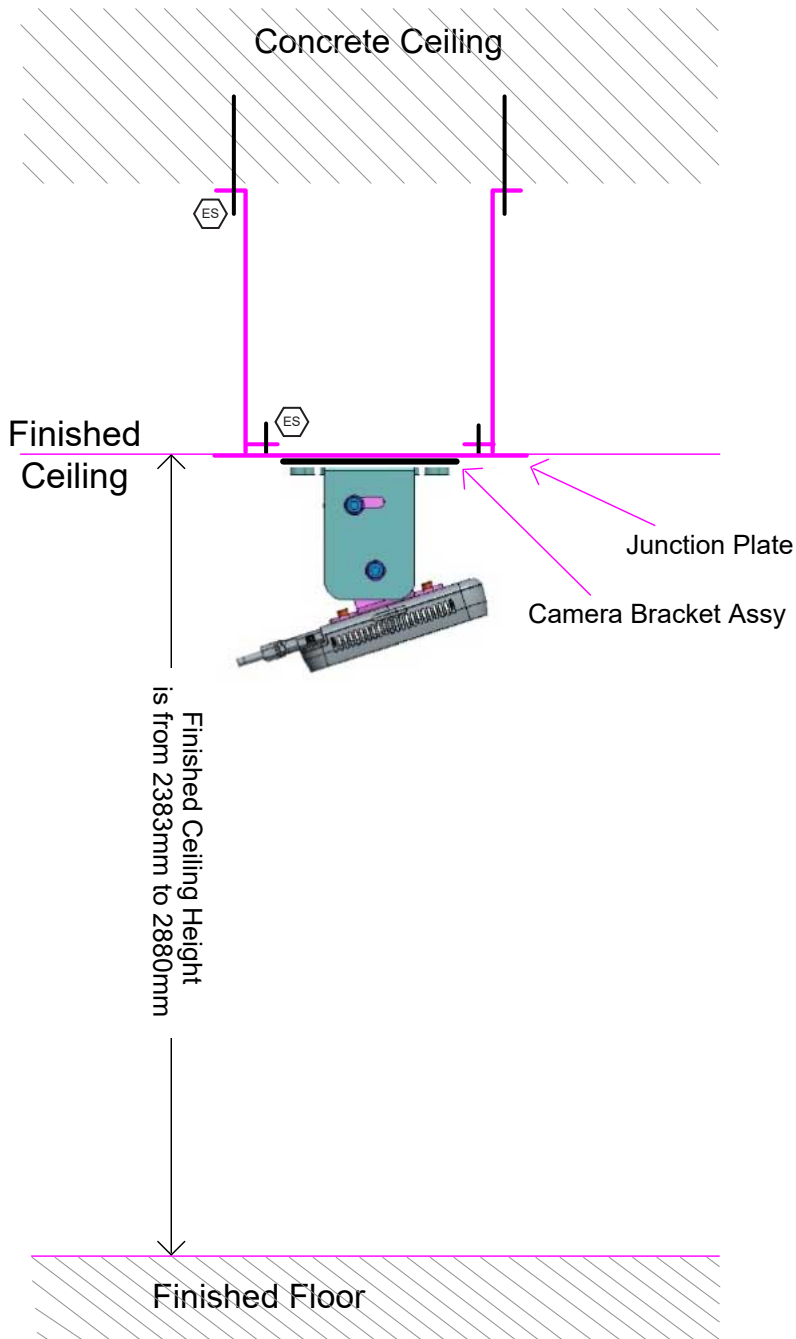

- **Case C: Camera Above finished ceiling**

Camera installation height is higher than the finished ceiling upper surface height, a rectangular hole needs to be opened in the finished ceiling as requested.

**Figure 8-18 Camera Installation Position\_C**

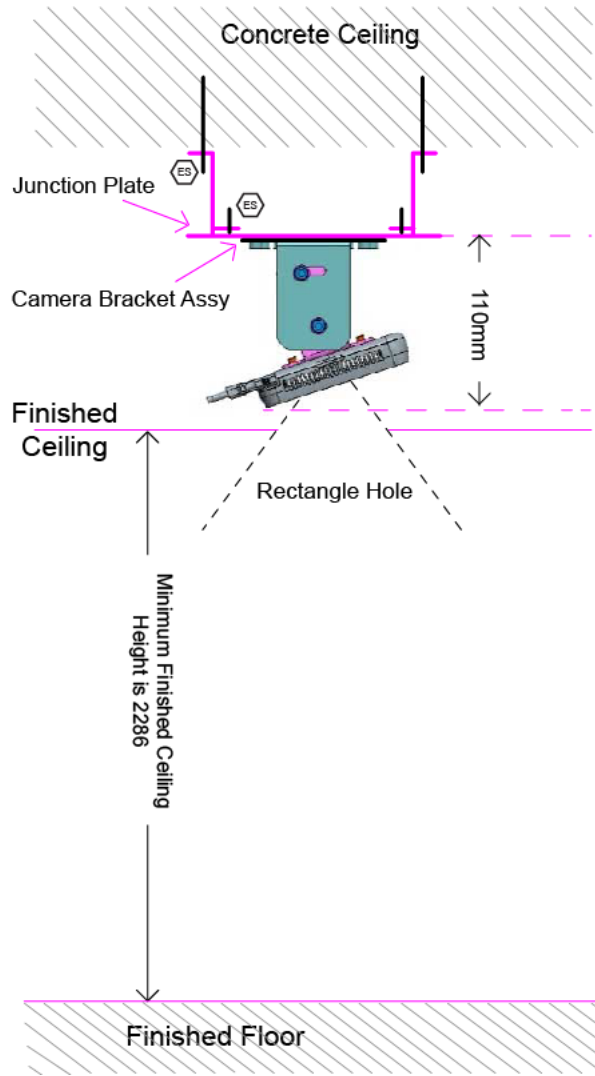

**NOTE**

Installation height of the Camera Bracket should be within 2383 ~ 2880mm regardless of finished ceiling height or junction plate height.

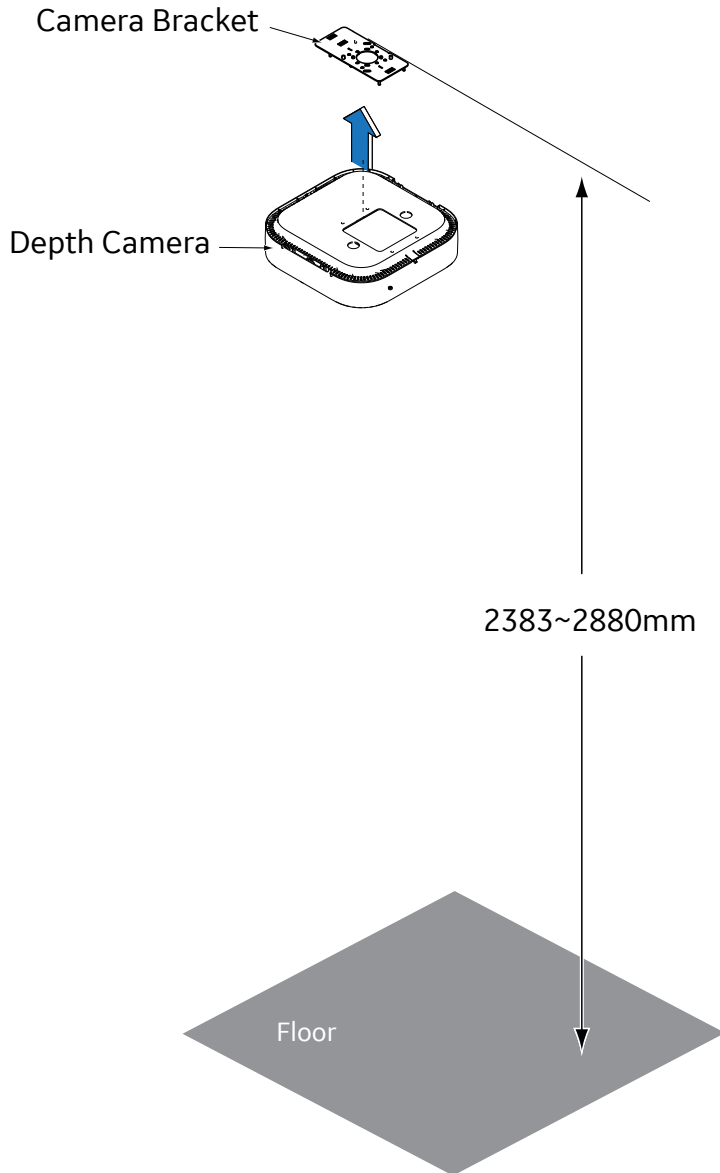
**Figure 8-19 Camera Bracket Height**

## 8.2.4 Ceiling Requirement for AVIMOS Camera

AVIMOS needs the cameras to get the proper video for doctor/technologist to view the gantry internal / external laser lines, table movement and monitor patient. Then particular area/sharpness for each video is required. Where to locate the camera and how to adjust direction is important.

If customer has purchased RCK with AVIMOS kit, please refer to **Remote Control Kit with Assisted Video Monitoring System Manual (5863844-1EN)** from SIMS Content Viewer for details.

### 8.2.4.1 AVIMOS Camera Installation Typical Layout

Figure 8-20 RCK-AVIMOS Schematics Diagram

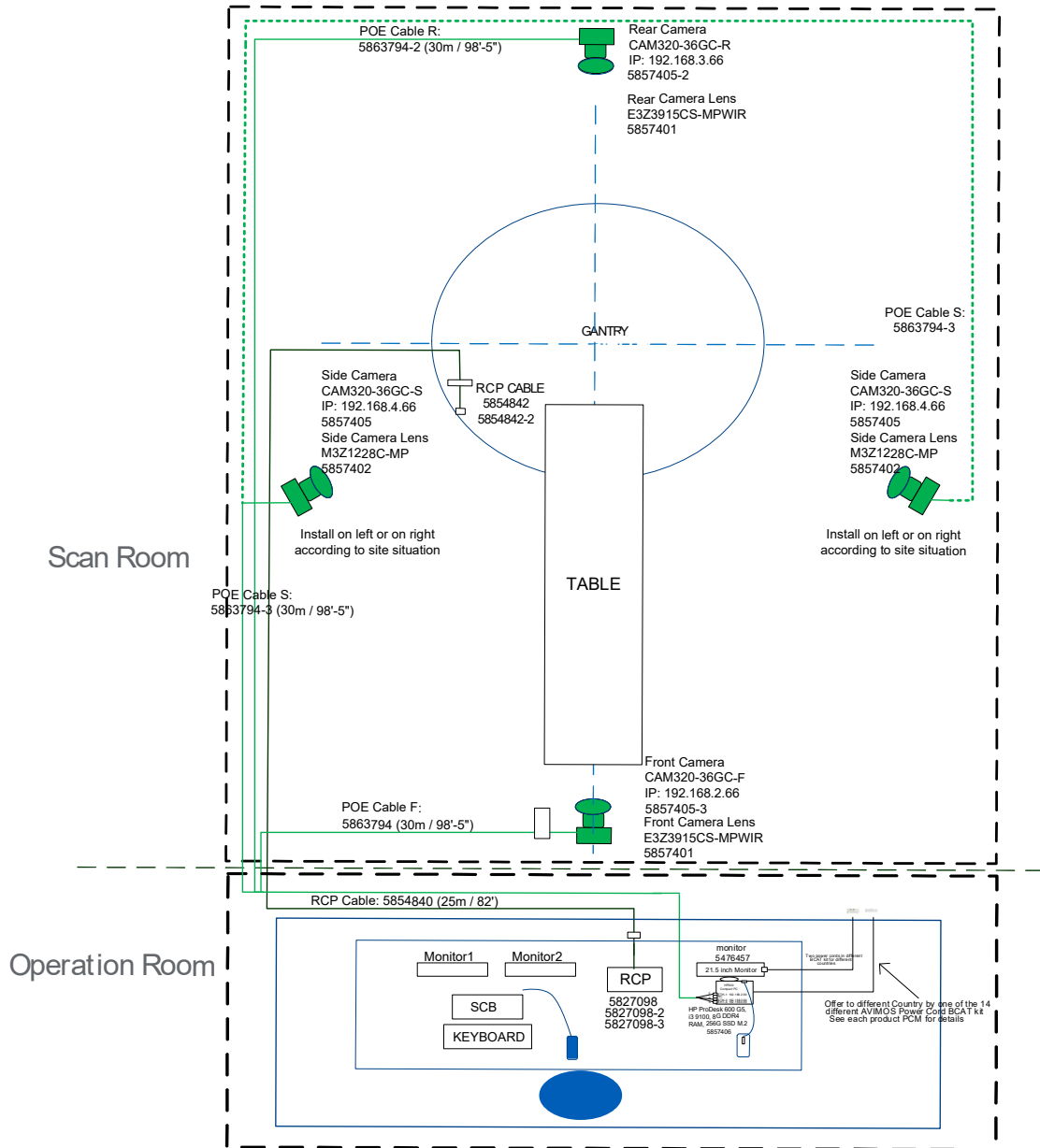
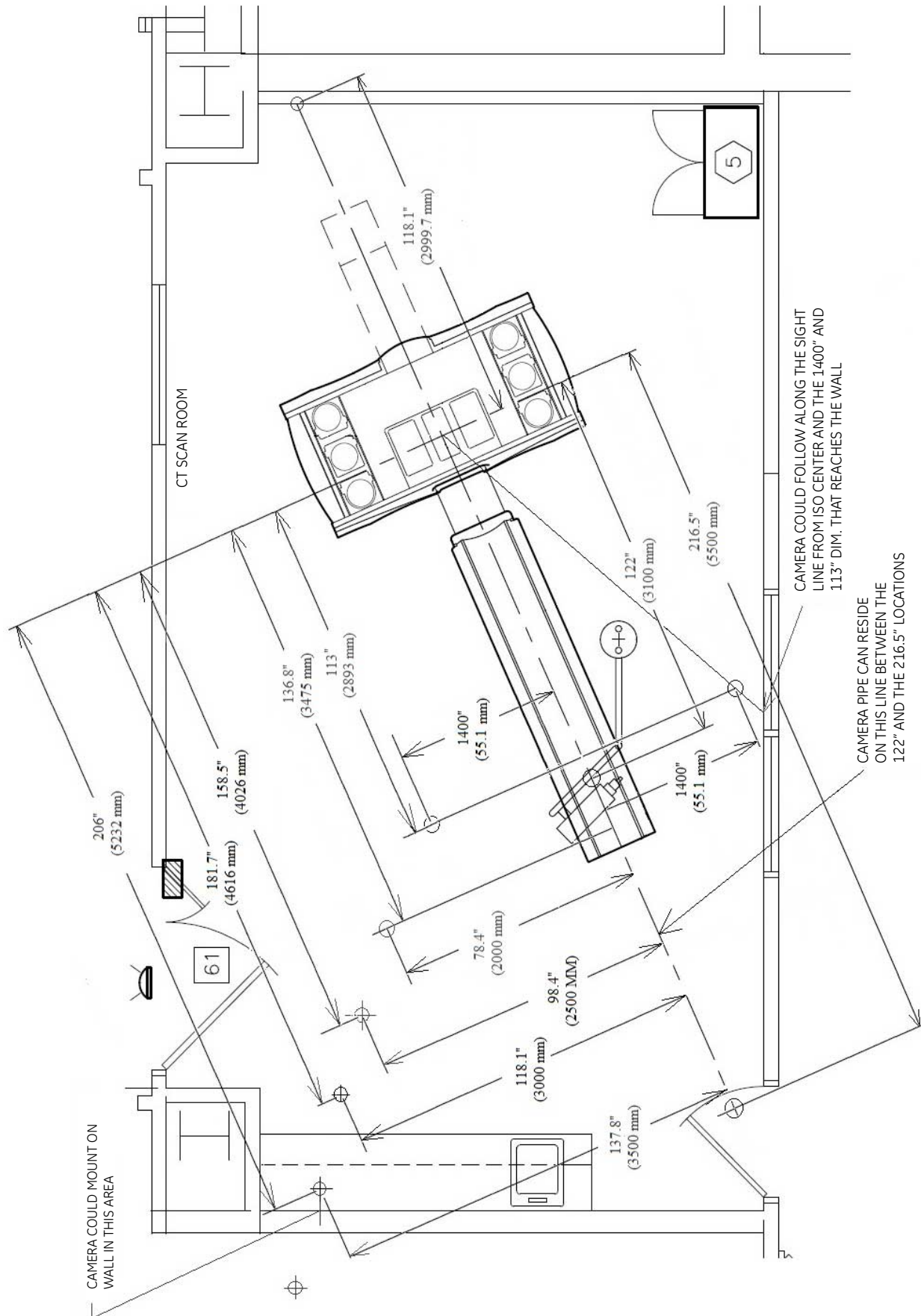

Figure 8-21 Example for Camera Position



### 8.2.4.2 Junction Plate Requirement

GE will provide two junction plates (Standard - 5863746 and Pipe - 5863748). If the junction plates supplied by GE can not meet the requests of the building structure, the customer’s architect can design and install the equivalent junction plate with sufficient strength to hold the camera.

**WARNING**



The customer’s architect is responsible for installing of junction plate. The system manufacturer will NOT inspect and test that the fixing methods between the Junction Plate and the building structure meet the loading capacity specified (recommend a 4x safety factor).

#### 8.2.4.2.1 Standard Junction Plate

Figure 8-22 Standard Junction Plate (Supplied by GE)

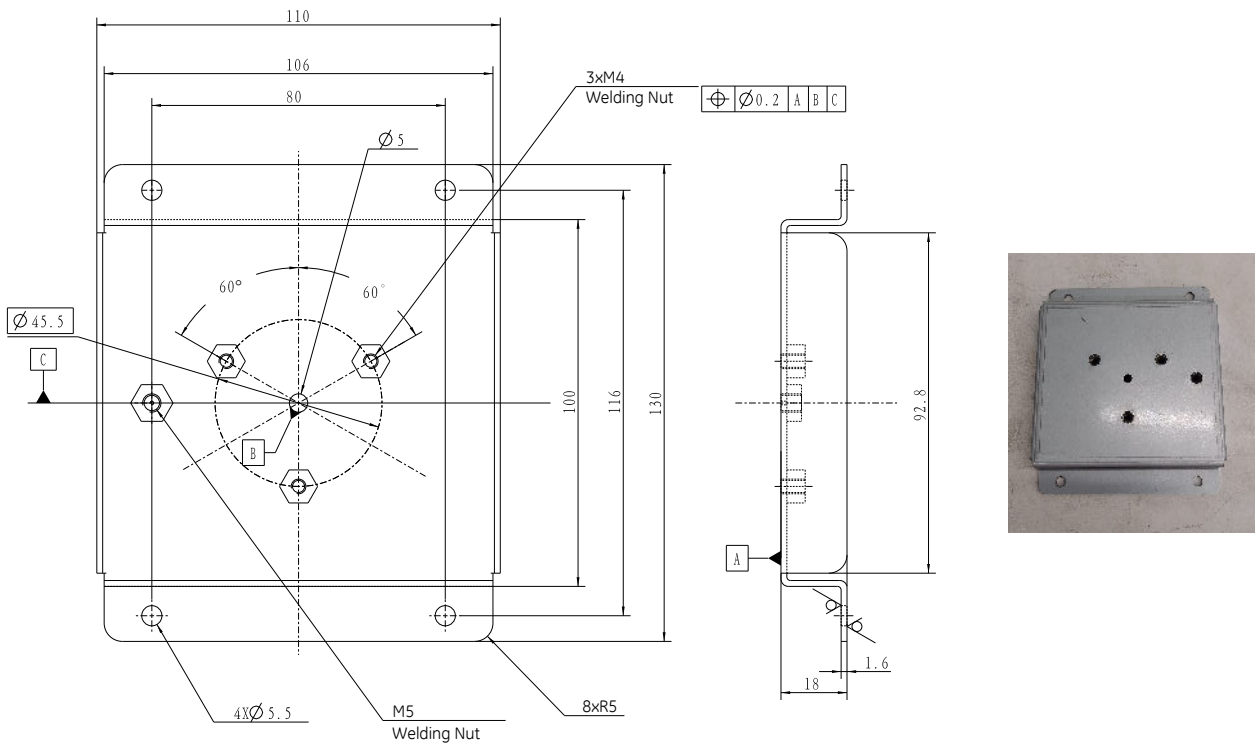

**Figure 8-23 Center of Gravity**

 Center of Gravity for Standard Configuration

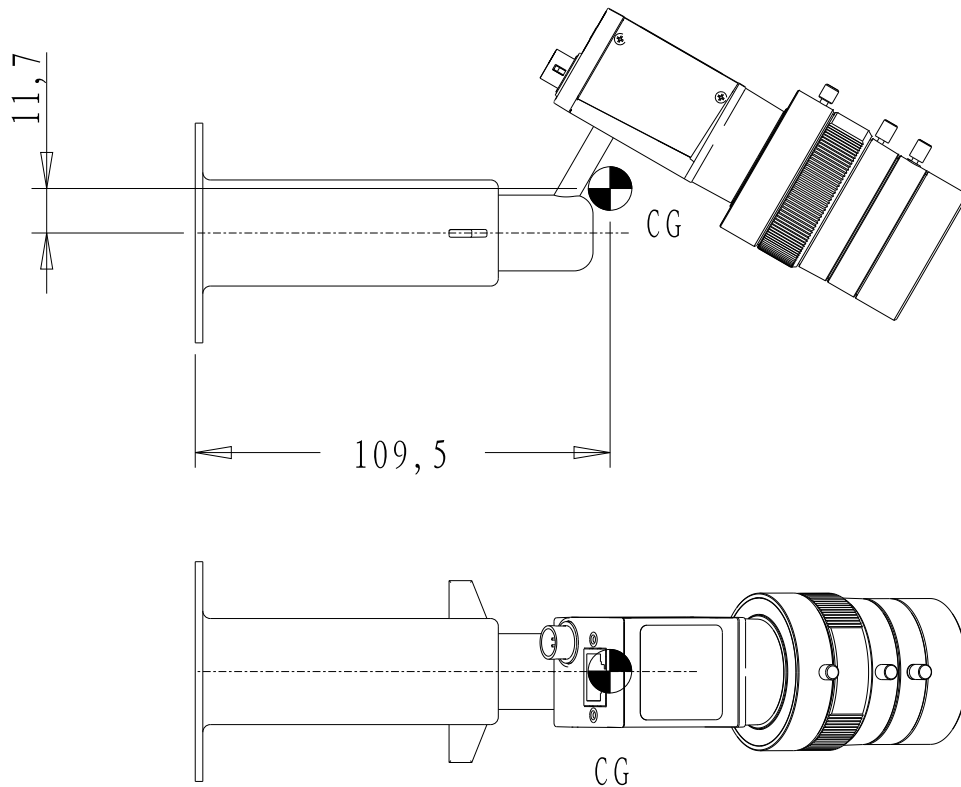

If a structural contractor designed an equivalent flat plate, the thickness should be 15mm or more, three (3) M4 mounting holes are required to anchor the camera bracket to the junction plate and one (1) M5 hole is used to anchor the safety chain. Please consider the loading capacity of the junction plate, the total weight of the camera and bracket provided by GE is 0.335kg.

The detailed instruction for hole size refers to [Figure 8-22 Standard Junction Plate \(Supplied by GE\) on page 79](#) and [Figure 8-23 Center of Gravity on page 80](#).

### 8.2.4.2.2 Junction Plate for Pipe

Figure 8-24 Junction Plate for Pipe (Supplied by GE)

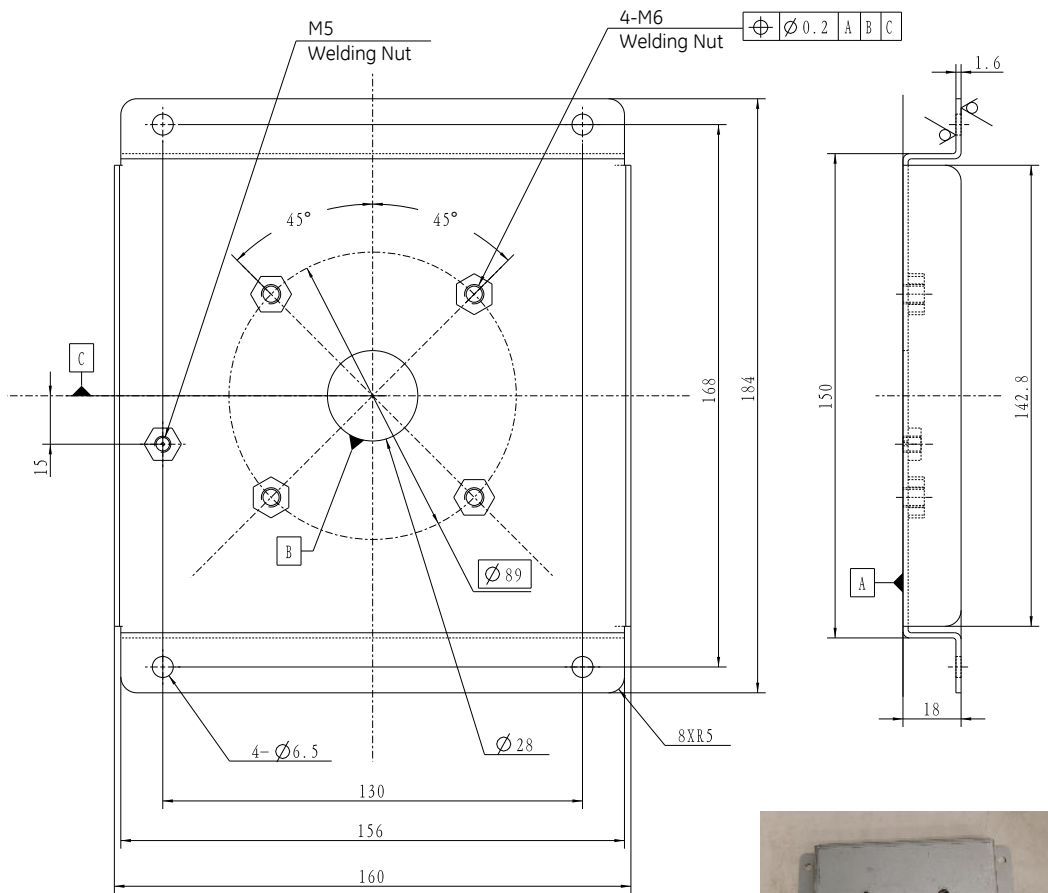

GB-T 13681-1992 Welding Nut		
	M5	M6
thickness (mm)	3.7 - 4	4.7 - 5
pledge load (N)	11000	15500

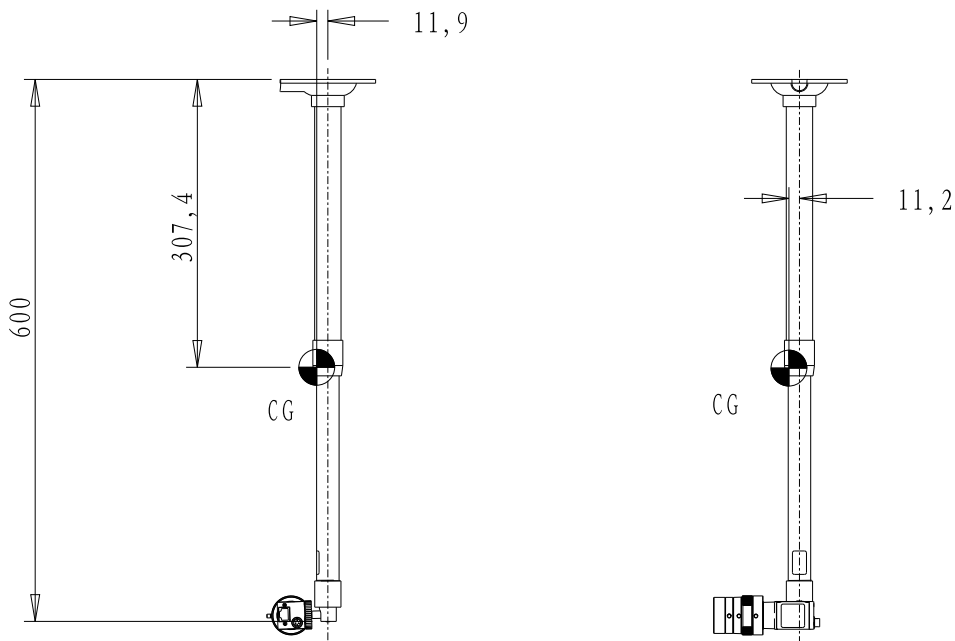

**Figure 8-25 Center of Gravity**
 Center of Gravity for Pipe Configuration

If a structural contractor designed an equivalent flat plate, the thickness should be 15mm or more, four (4) M6 mounting holes are required to anchor the camera bracket to the junction plate and one (1) M5 hole is used to anchor the safety chain. Please consider the loading capacity of the junction plate, the total weight of the camera and extendable pipe provided by GE is 0.665kg.

The detailed instruction for hole size refers to [Figure 8-24 Junction Plate for Pipe \(Supplied by GE\)](#) on page 81 and [Figure 8-25 Center of Gravity](#) on page 82.

### 8.2.4.3 Cable Requirement

Figure 8-26 Cable Connection

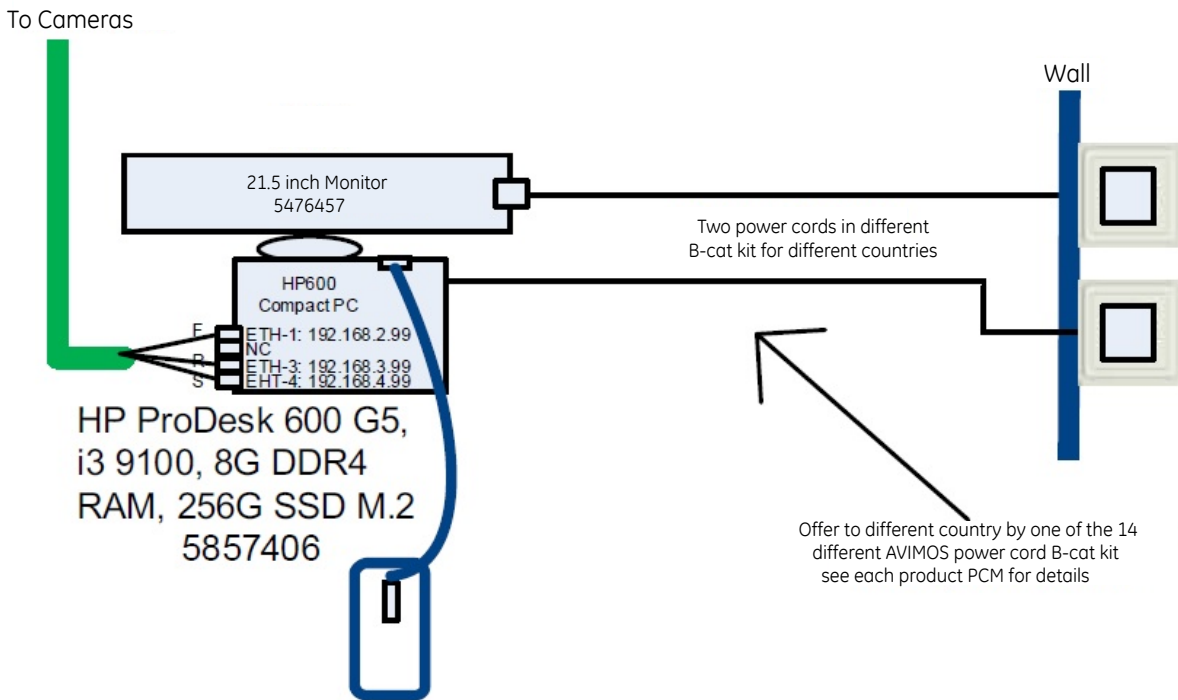

#### 8.2.4.3.1 LAN Cable Requirement

RCK-AVIMOS has three LAN cables, which need to be routed from the operating room to the scan room, so the customer should complete cable-conduit installation on ceiling in advance. (Refer to [Figure 8-20 RCK-AVIMOS Schematics Diagram on page 77](#))

#### 8.2.4.3.2 Power Cable Requirement

AVIMOS power cord should meet global all countries/regions, there are 14 selectable Power Cord Kits for different countries. (See [Figure 8-26 Cable Connection on page 83](#))



**NOTE**

The computer and monitor of AVIMOS needs to be placed in scan room because of cameras adjustment, please ensure that the wall output voltage in the scan room meets the requirements of the computer and LCD monitor.

Table 8-2 Computer and Monitor Voltage Requirement

Component	Element	Range
HP600 Computer	Mains input Volts / Amperes / Frequency	100-240VAC, ~/2.3A, 50-60Hz
LCD Monitor	Mains input Volts / Amperes / Frequency	100-240VAC, 0.75-0.40A (1.3A for Mexico), 50/60Hz

## 8.3 Minimum Floor Requirements

### 8.3.1 Floor Levelness Specification

#### 8.3.1.1 Critical Specifications

Accurate patient positioning during scanning depends on proper alignment of the gantry and the table. The floor levelness specifications in [Table 8-3 CRITICAL SPECIFICATIONS for Floor Levelness on page 84](#) ensure that the table and gantry height adjusters have enough range to allow proper leveling of the system.

**Table 8-3 CRITICAL SPECIFICATIONS for Floor Levelness**

Specification	Metric (minimum)	English (minimum)
Levelness	6 mm maximum variance over 3048 mm	1/4 in. maximum variance over 10 ft

#### 8.3.1.2 Floor Levelness Guidelines

Consider the following factors when determining floor levelness:

- Factors that can disturb the levelness of a weak floor, including:
  - Moving weights such as gurneys or heavy personal equipment.
  - Changes in the system's center-of-gravity when the table moves, as the table can carry a load capacity of up to Lite Table with 205kg (450lbs) / GT Table with 227kg (500lbs).
- Resilient tile, carpeting, or equivalent that may yield or compress over time. At sites with such floor coverings, be sure to cut away the tile or carpeting where the table and gantry adjusters touch the floor to expose the stable base material upon which to seat the adjusters.
- Floor shims are NOT PERMITTED.
- Refer to the steps listed in [8.3.1.3 Measuring Floor Levelness on page 84](#) to check whether the floor of the scan suite meets the floor levelness specifications for the system.

#### 8.3.1.3 Measuring Floor Levelness

1. Identify the position of the gantry and table in the room per the GE print. Everything matches the GE print, continue.

**Figure 8-27 GE Print with GT Table**

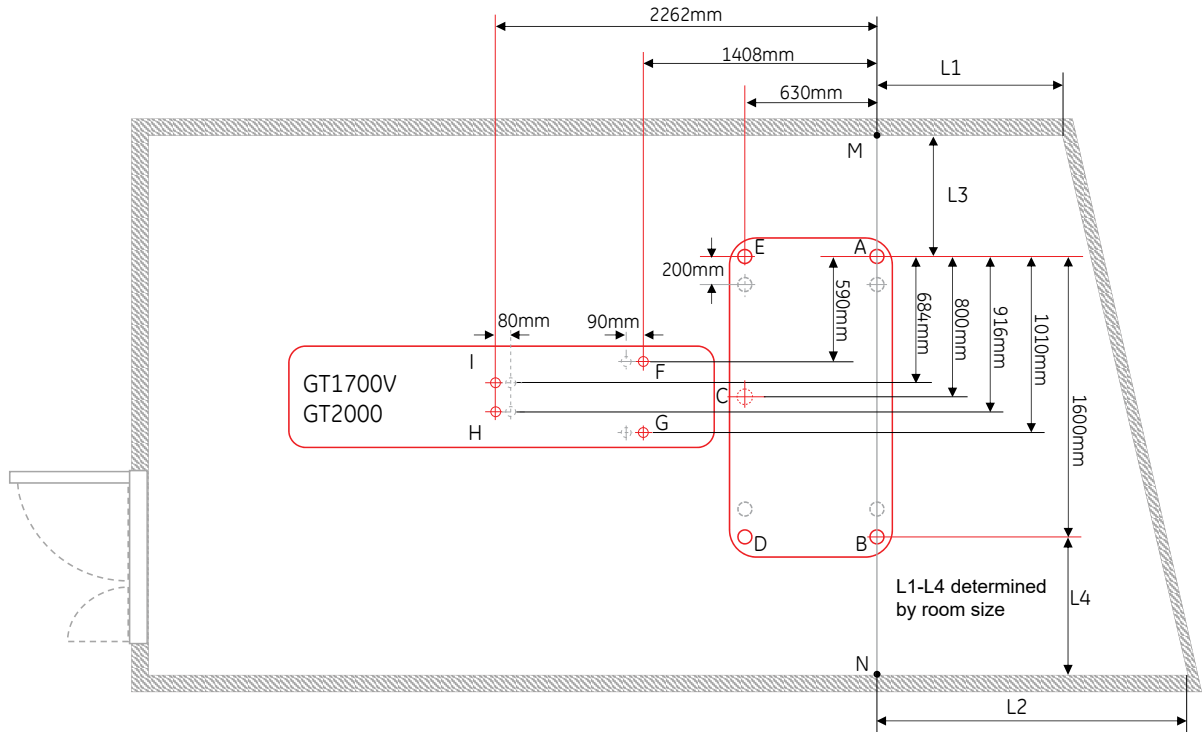

**Figure 8-28 GE Print with Lite Table**

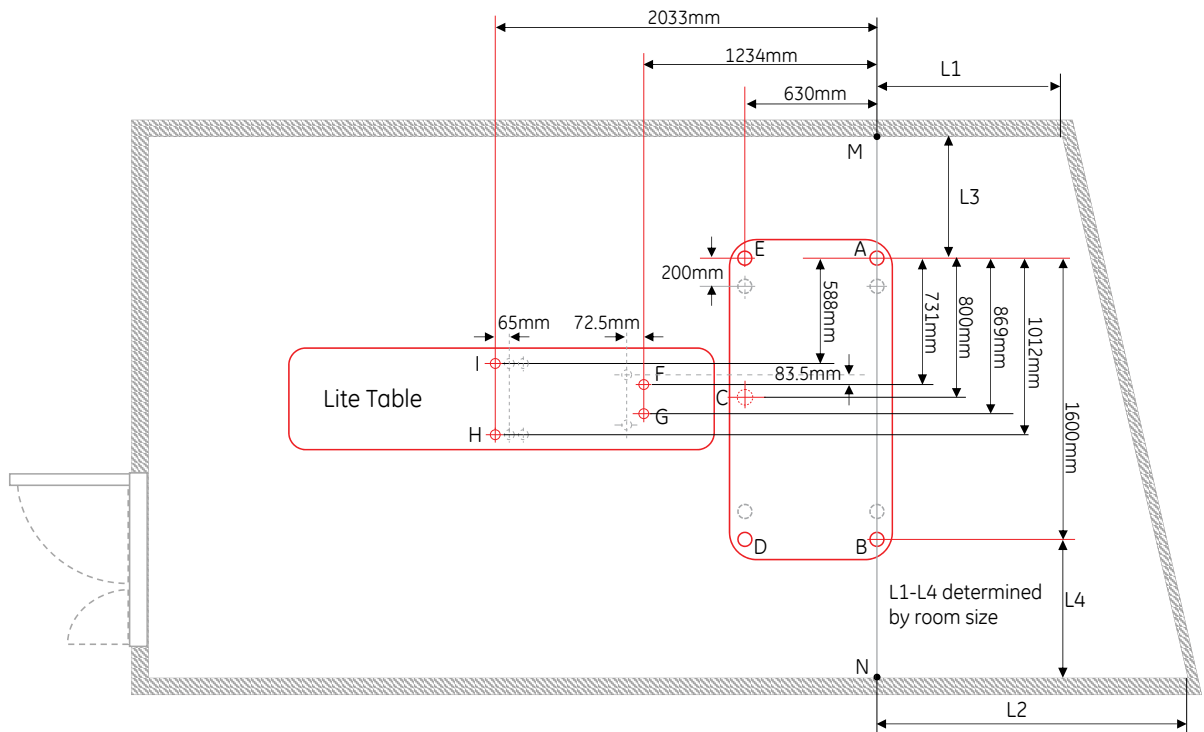

2. Make sure there are no potential clearance issues. If there are floor obstructions, such as conduits or old anchors, be sure to cut them flush to the floor to prevent the gantry from resting on them. Also, be sure there is at least 102 mm (4 in.) of clearance between any existing floor penetration and the new gantry position.

- Place the bubble-level on the approximate position of the Gantry and Table to check the levelness of the floor across the entire area covered the Gantry and Table, as shown in [Figure 8-29 Check Floor Levelness on page 86](#).

**NOTE**

If the floor is not level, your system cannot be properly aligned.

**Figure 8-29 Check Floor Levelness**

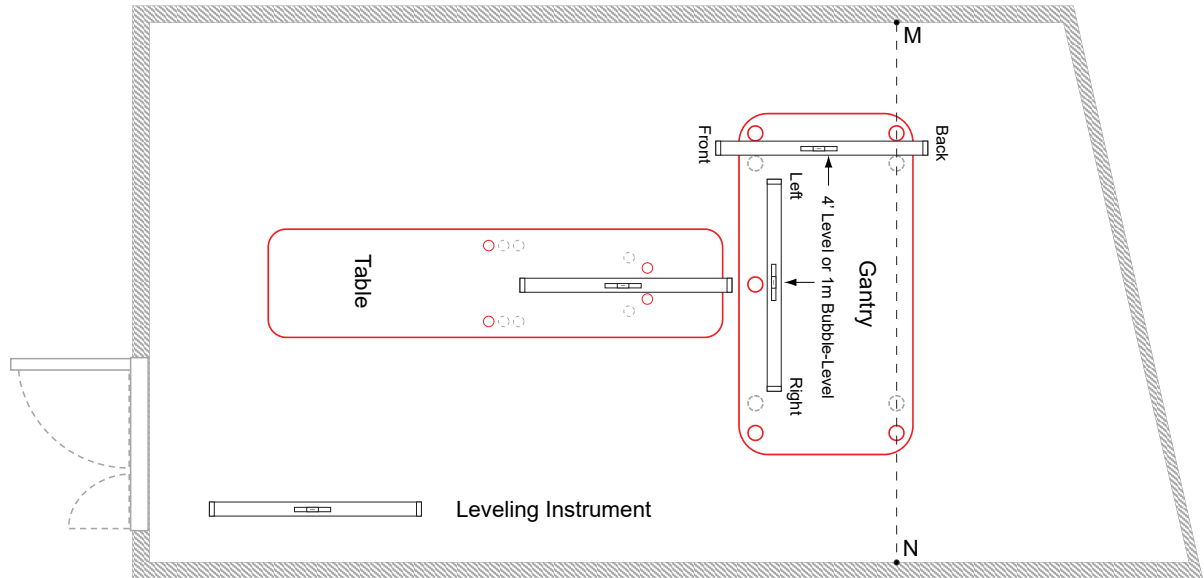

## 8.3.2 Scan Window

The recommended patient viewing window dimensions are 1219 mm wide x 1067 mm high (48 in. x 42 in.). The location of the window is dependent on the position of the operator workspace position. Consult Radiation Protection Requirements and a qualified radiological health physicist for radiation protection requirements of the window glass (lead content and thickness).

**NOTE**

The operator at the operator workspace must be able to view the patient during a scan.

## 8.3.3 Floor Vibration Specification

### 8.3.3.1 Requirements

CT systems are sensitive to vibration and may display limited performance if exceeding the vibration limits listed below. The band of frequencies in which systems exhibit the most sensitivity appears at or near the resonant frequencies of the gantry and the patient table, the latter of which varies depending on patient mass and location. These frequencies fall within the following ranges:

- Patient Table: 2 - 10 Hz
- Gantry: 8 - 14 Hz

Floor vibration from any intermittent or continuous source, such as walking, running, exercising, mechanical equipment, and traffic, must not exceed the levels shown in [Figure 8-30 Allowable floor vibration in velocity units compared to ISO class A & B limits on page 87](#) or [Figure 8-31 Allowable floor vibration in acceleration units compared to ISO class A & B limits on page 88](#),

as represented by the solid line labeled CT system/Table. These figures compare this limit to the limits of what the AISC (American Institute of Steel Construction) and the ISO (International Organization for Standardization) call Class A (VC-A) and Class B (VC-B).

**NOTE**

In Figure 8-30 Allowable floor vibration in velocity units compared to ISO class A & B limits on page 87 and Figure 8-31 Allowable floor vibration in acceleration units compared to ISO class A & B limits on page 88 the symbol  $\mu$  represents  $10^{-6}$ .

The preferred format for measuring vibration is velocity versus frequency, as shown in Figure 8-30 Allowable floor vibration in velocity units compared to ISO class A & B limits on page 87. However, should it prove necessary to measure acceleration and there is no means to convert the measured data to velocity, then use the equivalent acceleration limit shown in Figure 8-31 Allowable floor vibration in acceleration units compared to ISO class A & B limits on page 88, derived from the velocity spectrum.

**Figure 8-30 Allowable floor vibration in velocity units compared to ISO class A & B limits**

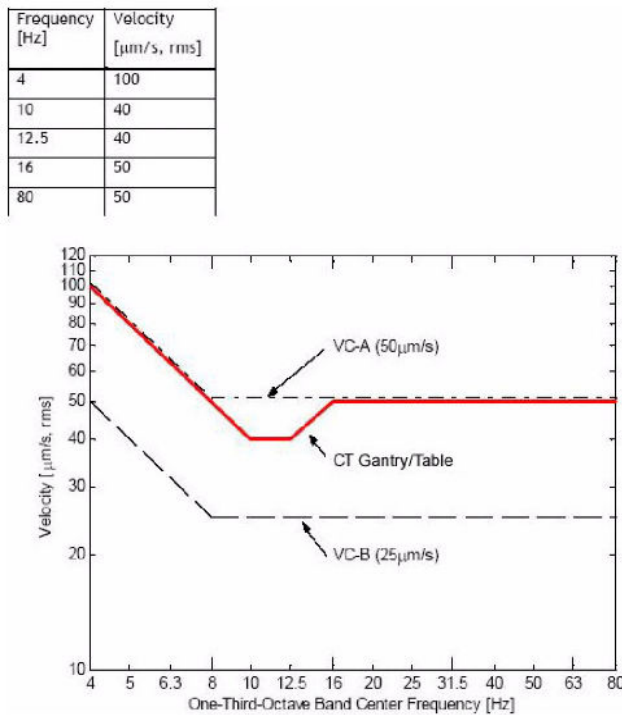

**Figure 8-31 Allowable floor vibration in acceleration units compared to ISO class A & B limits**

Frequency [Hz]	Acceleration [mm/s <sup>2</sup> , rms]
4	2.5
10	2.5
12.5	3.1
16	5
80	25

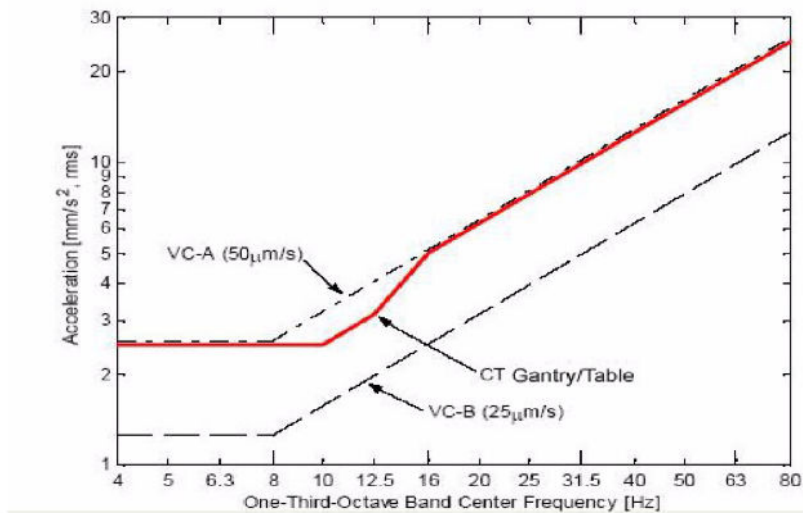

### 8.3.3.2 Sources of Floor Vibration

Consider that vibrations strong enough to affect the floor may emanate from the following sources in and around the scanning facility, requiring possible isolation of the floor or structure from them:

- Hospital power plants housing pumps, motors, air handling equipment, or air conditioning units
- Hallway foot traffic
- Elevators
- Parking lots
- Roadways
- Subways
- Trains
- Heliports

### 8.3.4 Floor Strength

Concrete floors must have a minimum strength of  $f'c = 2500$  psi ( $1.7 \times 10^7$  pa) at 28 days for (curing time) mounting floor anchors. It is the responsibility of each customer to have appropriate tests performed to determine and measure concrete strength.

## 8.4 Floor Loading and Component Weights

The customer's contractor and structural engineer should use the information in [Table 8-4 Component Weight and Floor Loading Data on page 89](#) to help determine if the floor structure in the scan suite possesses sufficient strength to support the weight of the system.

**Table 8-4 Component Weight and Floor Loading Data**

System Component	NET Weight kg (lb)	Overall W x D mm (in.)	Max Uplift Load N (lb) <sup>2</sup>	Max Compressive Load N (lb)	Load Pattern mm (in.)
Gantry	1558 (3434)	2041 x 1014 (80 x 40)	0	4614 (1038)	Four round 64 mm (2.5 inch) diameter pads on concrete floor
Dolly (each)	140 (309)	864 x 510 (34 x 20)	-	-	Four casters
Lightweight Dolly (each)	87 (192)	864 x 510 (34 x 20)	-	-	Four casters
GT2000 Table <i>with 227kg (500lb) load capacity</i>	732 (1613)	650 x 2910 (25.6 x 114.5)	1455 (327)	5210 (1170) <sup>1</sup>	Four round 64 mm (2.5 inch) diameter pads on concrete floor
GT1700V Table <i>with 227kg (500lb) load capacity</i>	672 (1481)	650 x 2370 (25.6 x 93.3)	1455 (327)	4745 (1067) <sup>1</sup>	Four round 64 mm (2.5 inch) diameter pads on concrete floor
Lite Table <i>with 205kg (450lb) load capacity</i>	525 (1157)	650 x 2347 (25.6 x 92)	2358 (530)	4972 (1118) <sup>1</sup>	Round 50 mm (2 inch) diameter pads on concrete floor
Power Distribution Unit	370 (816)	700 x 550 (27.5 x 21.6)	0	1070 (240)	Four casters
OpenOC with Z8G4	64.2 (142)	400 x 672 (16 x 26)	-	-	-
OpenOC with Z8G5	63.1 (139)	400 x 672 (16 x 26)	-	-	-
StandAlone (Z8G4)	31.7 (70)	216 x 551 (8.5 x 21.7)	-	-	-
StandAlone (Z8G5)	23.1 (51)	216 x 555 (8.5 x 21.7)	-	-	-
Power Box	10.5 (23.1)	350 x 256 (13.8 x 10)	-	-	-
LCD Monitor (each)	9 (20)	420 x 247 (16.5 X 9.7)	-	-	-
SWS Desk (5449758-2)	40 (88)	1300 x 850 (51 x 33)	-	-	-

**Table 8-4 Component Weight and Floor Loading Data** (Table continued)

System Component	NET Weight kg (lb)	Overall W x D mm (in.)	Max Uplift Load N (lb) <sup>2</sup>	Max Compressive Load N (lb)	Load Pattern mm (in.)
<sup>1</sup> <b>Note:</b> Loads provided for table support with patient in worst-case-scenario positioning.					
<sup>2</sup> <b>Note:</b> Indicates maximum load for one anchor bolt.					

## 8.4.1 Floor Loading and Anchoring Guidelines

Follow the floor loading and anchoring guidelines below when preparing a site for system installation:

- The table and gantry require secure anchoring to the scan room floor. The power distribution unit and the console sit on the floor with casters; anchoring of these components to the floor is optional, unless required because of seismic considerations.
- For total floor load of system with GT2000/GT1700V/Lite Table and no UPS, refer to [Table 8-4 Component Weight and Floor Loading Data on page 89](#).
- When carrying the heaviest possible patient, the table-gantry-footswitch assembly represents a concentrated load within the scan room. Refer to [Table 8-4 Component Weight and Floor Loading Data on page 89](#) for total weight.
- Anchors mount through the table and gantry supports. Use the gantry/table alignment tool to locate the table and gantry support positions within the scan room, making sure that any anchors that pass through the supports clear all structural beams and interferences in the floor.
- If a loading analysis determines that the gantry and table position should change relative to their position on the GE site print, be sure to take into account the clearance requirements in [4 Regulatory Requirements on page 31](#) and [5 Service Clearance Requirements on page 33](#) when determining an appropriate location for the system.
- Hospitals and scanning facilities throughout the world should follow the instructions and adhere to the flooring requirements specified by GE:
  - Wood floors often require substantial reinforcements, hence GE strongly suggest not to use wooden floors for anchoring table and gantry.
  - Temperature variation in blacktop or marble floors allow anchor movement and pullout, hence GE strongly suggests not to use these floors for anchoring table and gantry.
  - GE recommends using concrete floors with a minimum thickness of 102 mm (4 in.) for Gantry and GT Table / 110 mm (4-1/3 in.) for Lite Table. [Table 8-6 Table and Gantry Anchoring Requirements on page 92](#) describe embedment depth, hole depth, minimum concrete thickness etc. for table anchoring.
  - Customers should use GE supplied/specified anchors only.



### ESSENTIAL TO SAFETY!

GE strongly suggests not to use any alternate anchoring methods; GE accepts no responsibility for any failure of the support or the anchoring method, including those used for seismic mounting. GE accepts no responsibility for methods other than those listed. The customer is responsible for meeting all code requirements specific to the site and for this product when using alternate system anchoring.

## 8.4.2 Anchor Edge Distance Definition

The edge distance of Table and Gantry floor anchor must meet following requirements:

- **Gantry and GT Table:**

Using Hilti KWIK 0.5inch DIA\*7 inch long anchor (P/N: 5874830-2 / 5487992-2)

The distance from CL of anchor to the edge of concrete basement of Gantry / GT Table should not be less than 178mm, which is necessary to keep anchor full tension strength  $f_{RN}$ .

- **Lite Table:**

Using Hilti KWIK 0.5inch DIA\*4.5 inch long anchor (P/N: 5874830)

Using Hilti KWIK 0.5inch DIA\*5.5 inch long anchor (P/N: 2106573-3)

The distance from CL of anchor to the edge of concrete basement of Lite Table should not be less than 178mm, which is necessary to keep anchor full tension strength  $f_{RN}$ .

### NOTICE

Responsibility for providing an approved support structure and mounting method for all floor types other than the GE-recommended floor rests with the purchaser. General Electric accepts no responsibility for any failure of the support structure or anchoring method, including those used for seismic mounting. GE accepts no responsibility for methods other than those listed.

## 8.5 GE-Supplied Anchoring

GE supplies anchors for mounting the table and gantry. The console and power distribution unit do not require anchoring to the floor. It is the responsibility of the customer to have a structural engineer and trained contractor to use either the GE-supplied anchoring method or to provide an equivalent anchoring method to mount the table and gantry to the floor. Consult your architect, structural engineer, contractor, or PMI to resolve any questions.

### WARNING



POTENTIAL FOR PATIENT INJURY!

AN IMPROPERLY SECURED SYSTEM WILL CAUSE DAMAGE OR PERSONAL INJURY.

SYSTEM CAN MOVE OR TIP DURING OPERATION IF NOT PROPERLY SECURED.

PATIENT SAFETY DURING SYSTEM OPERATION REQUIRES PROPER ANCHORING OF THE SYSTEM.

### 8.5.1 Specifications of GE-supplied Anchors

[Table 8-5 GE-Supplied Anchor Specifications on page 92](#) lists the specifications of GE-supplied anchors for the system. There are two types of anchors used in this product. For a detailed view, including dimensions and additional specifications, see [Table 8-6 Table and Gantry Anchoring Requirements on page 92](#) of this section.

**Table 8-5 GE-Supplied Anchor Specifications**

<b>GE-Supplied Anchors</b>	<b>Gantry and GT Table</b>	<b>Lite Table</b>	
Part Number	5874830-2 / 5487992-2	2106573-3	5874830
Description	Hilti Kwik Bolt	Hilti Kwik Bolt 3	Hilti Kwik Bolt 1
Diameter	12.7 mm (0.5 in.)	12.7 mm (0.5 in.)	12.7 mm (0.5 in.)
Length	178 mm (7 in.)	140 mm (5.5 in)	114 mm (4.5 in)

## 8.5.2 Requirements for Using GE-supplied Anchors

Use of GE-supplied anchors ([Table 8-5 GE-Supplied Anchor Specifications on page 92](#)) shall adhere to the following requirements:

- Use the GE-supplied anchors ONLY when mounting components on concrete floors.
- Adhere to all anchoring requirements listed in [Table 8-6 Table and Gantry Anchoring Requirements on page 92](#).
- Any anchors showing more than specified length of thread above the torqued nut requires the installation of a second anchor in the closest adjacent mounting location. The second anchor shall meet the same requirements in [Table 8-6 Table and Gantry Anchoring Requirements on page 92](#).
- Non-seismic installations must use a minimum of four (4) anchors to mount the gantry and four (4) anchors to mount the table.
- Fully engage the Adjuster Lock Rings (only for Gantry) with at least one full thread showing below the notched portion on the Adjuster Screw.

**Table 8-6 Table and Gantry Anchoring Requirements**

<b>Mounting Requirements</b>	<b>Gantry and GT Table Anchor P/N 5874830-2 / 5487992-2</b>	<b>Lite Table Anchor P/N</b>	
		<b>2106573-3</b>	<b>5874830</b>
Minimum Floor Thickness	102 mm (4 in.)	110 mm (4.33 in.)	102 mm (4 in.)
Recommended Drilling Depth	85 mm (3.35 in.)	100 mm (3.94 in.)	85 mm (3.35 in.)
Average Anchor Embedment	75 mm (2.95 in.)	90 mm (3.54 in.)	68 mm (2.95 in.)
Minimum Anchor Embedment	63 mm (2.48 in.)	80 mm (3.15 in.)	63 mm (2.48 in.)
Available Alternate Anchor Locations	Yes	Yes	Yes
Shipped Anchor Size	178 mm (7 in.)	140 mm (5.5 in)	114 mm (4.5 in)
Alternate Anchoring Methods	Yes (see note, above)	Yes (see note, above)	Yes (see note, above)
Floor Levelness Requirement	6 mm (1/4 in.) over 3 m (10 ft)	6 mm (1/4 in.) over 3 m (10 ft)	6 mm (1/4 in.) over 3 m (10 ft)

**Figure 8-32 Gantry and GT Table Anchoring with 5874830-2 / 5487992-2 (7 in.) Anchor Bolt**

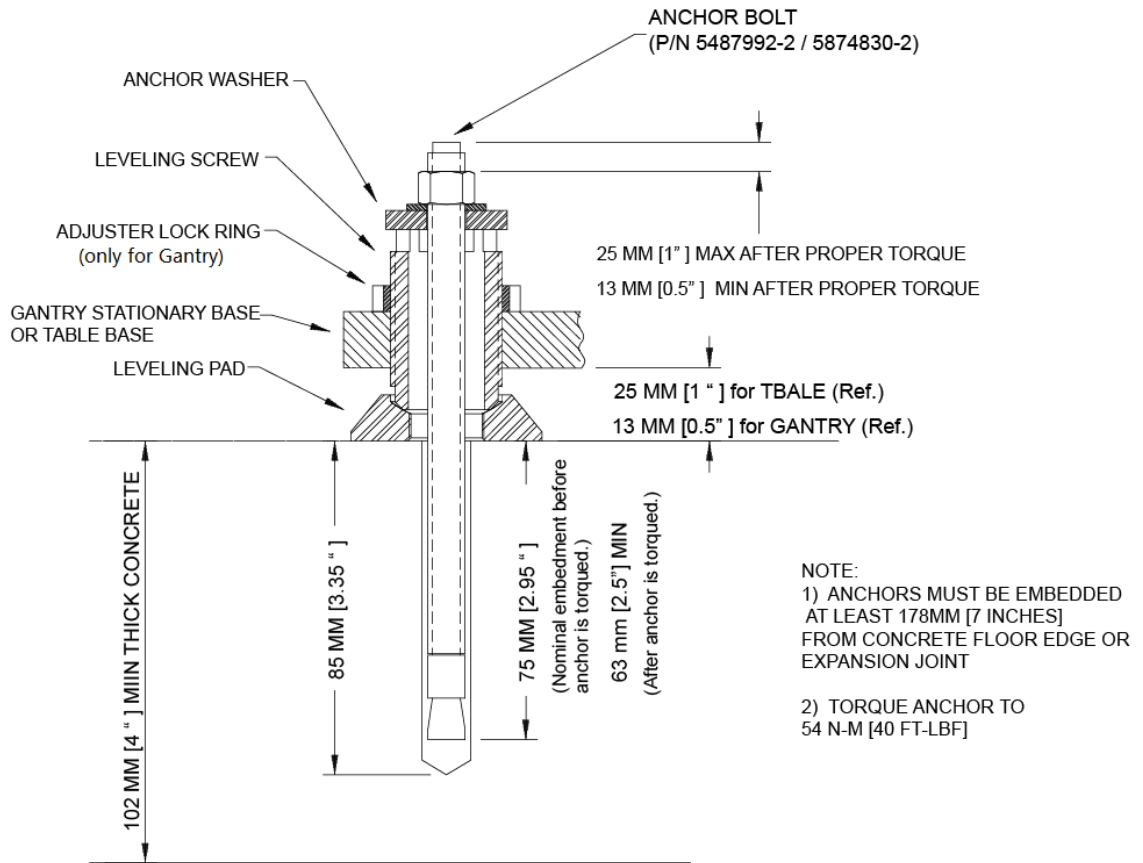

**Figure 8-33 Lite Table Anchoring with 2106573-3 Anchor Bolt**

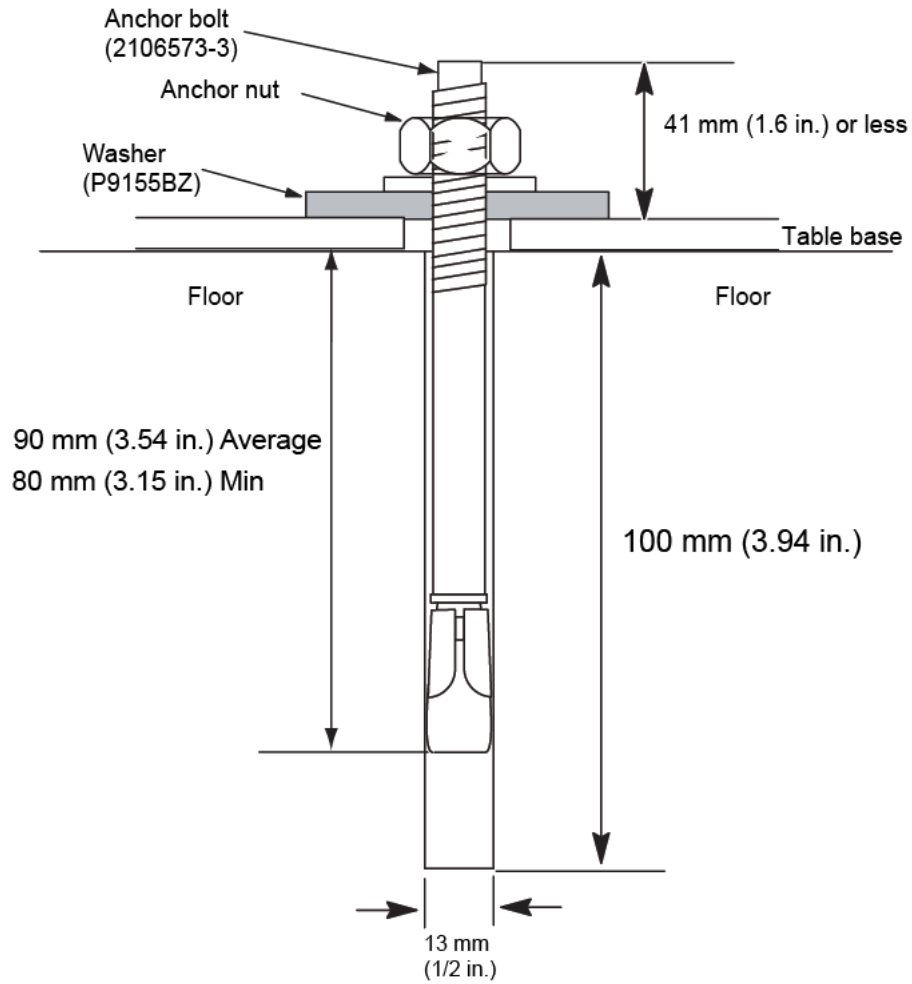

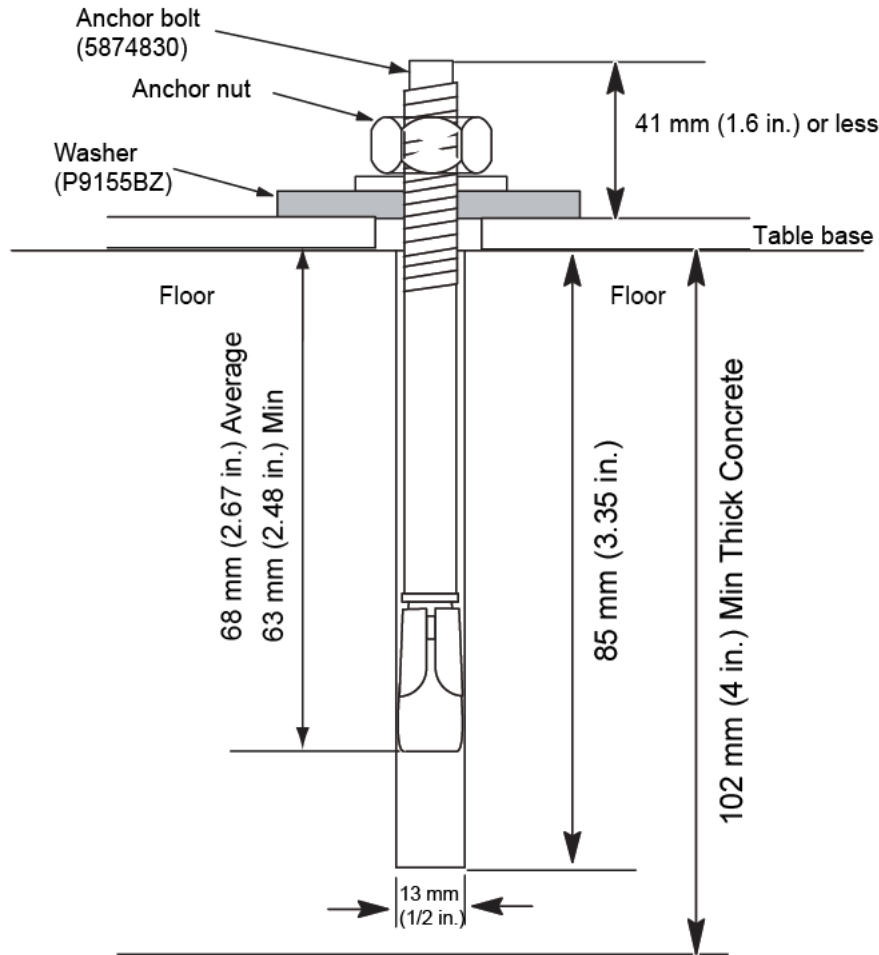
**Figure 8-34 Lite Table Anchoring with 5874830 Anchor Bolt**

## 8.6 Seismic Mounting

### 8.6.1 Overview

Refer to the guidelines in this section when mounting the system in seismic zones:

- Responsibility for proper seismic mounting rests with the customer. Refer to all applicable laws and codes for your locality.
- The customer's contractor often supplies a state-certified print or equivalent, showing seismic installation instructions.
- Consider seismic requirements for ceiling-mounted fixtures and refer to the appropriate installation instructions for ceiling-mounted fixtures.



#### NOTE

If customer has purchased Anti-Seismic Kit B76632DA, please refer to **Anti-Seismic Kit Instruction (5874514-1EN)** from SIMS Content Viewer for details.

**(For NGPDU seismic:)** PDU seismic brackets (2354563-2) and the PDU shipping kit (5453382-2) are shipped with the PDU. Detail bracket Installation procedure refer to Installation Manual.

**Figure 8-35 PDU Anti Seismic Bracket (2354563-2)**

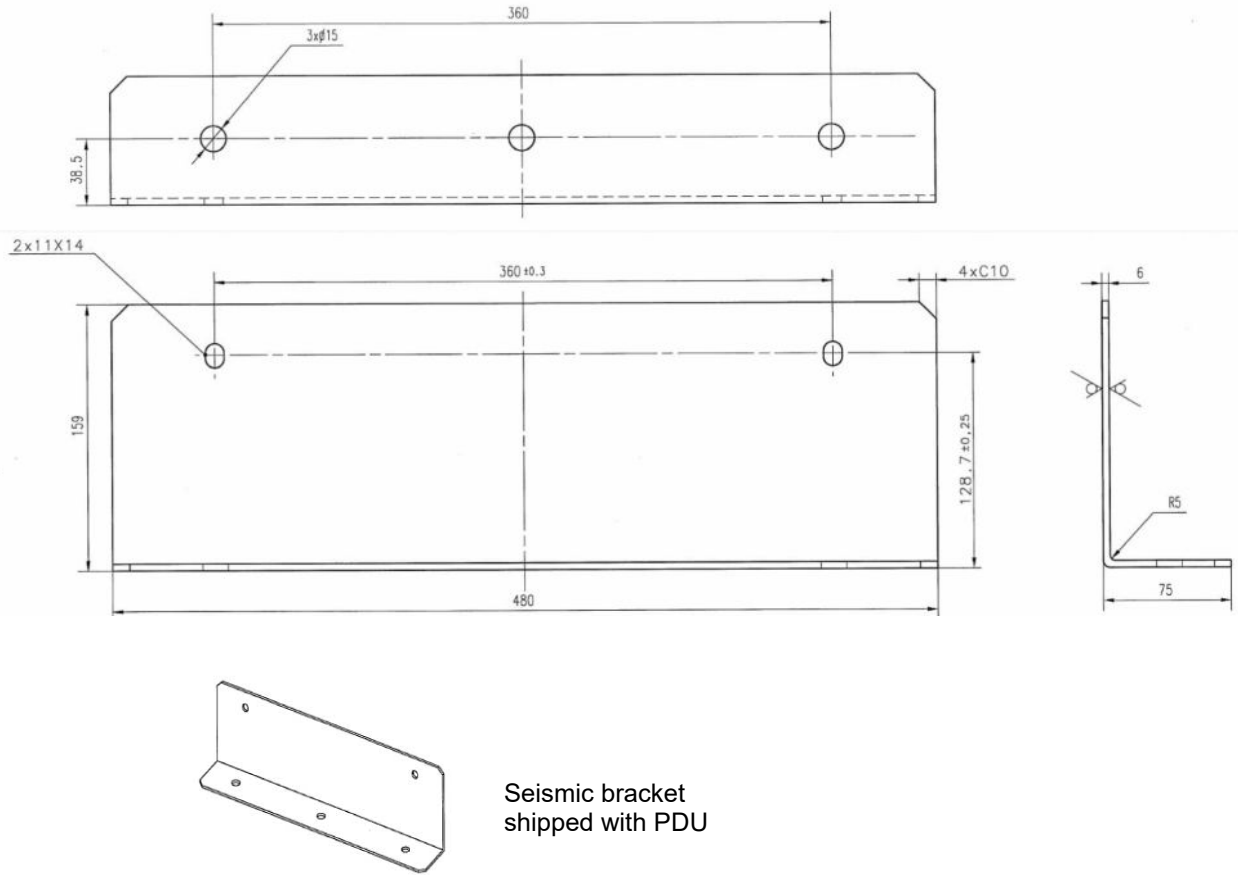

**(For OpenOC seismic:)** Console seismic brackets and screws are includes in Console Seismic Kit (5812703- 2) that are shipped with Console.

**Figure 8-36 OpenOC Console Anti Seismic Bracket (5357148-3)**

Material: STEEL Q/BQB 403 DCO1 FB

Thickness 4.0mm

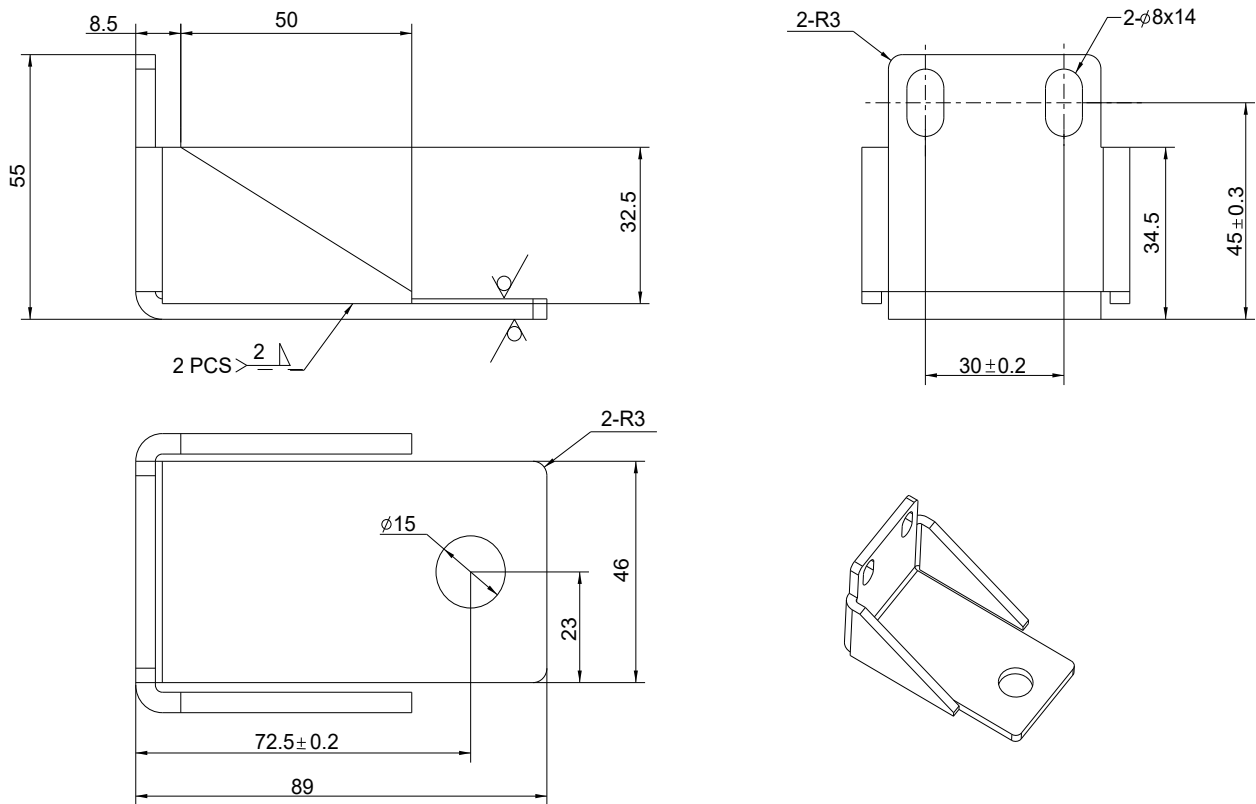

## 8.6.2 Center-of-Gravity Information

The information in the following figures provides the customer's contractor and/or structural engineer with center-of gravity information to assist in seismic calculations for the system:

- Console: [Figure 8-37 Open Console with Z8G4 Center-of-Gravity on page 98](#) and [Figure 8-38 Open Console with Z8G5 Center-of-Gravity on page 99](#).
- Gantry: [Figure 8-39 Gantry Center of Gravity on page 100](#)
- Table: [Figure 8-40 GT2000 Table Center-of-Gravity on page 101](#), [Figure 8-41 GT1700V Table Center-of-Gravity on page 102](#) and [Figure 8-42 Lite Table Center-of-Gravity on page 103](#)
- Power Distribution Unit: [Figure 8-43 PDU Center of Gravity on page 104](#) (PDU Seismic Mounting Bracket)

Figure 8-37 Open Console with Z8G4 Center-of-Gravity

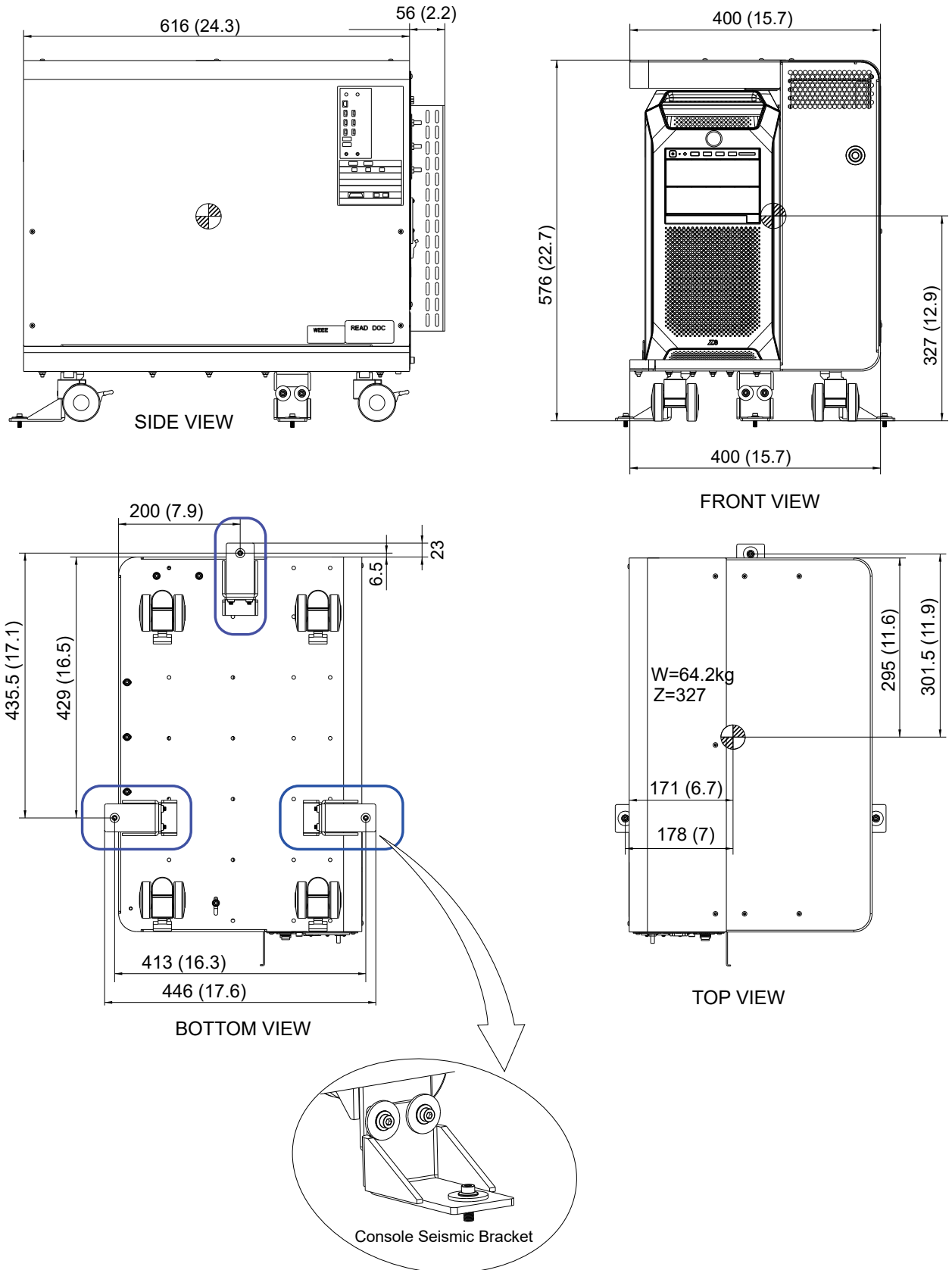
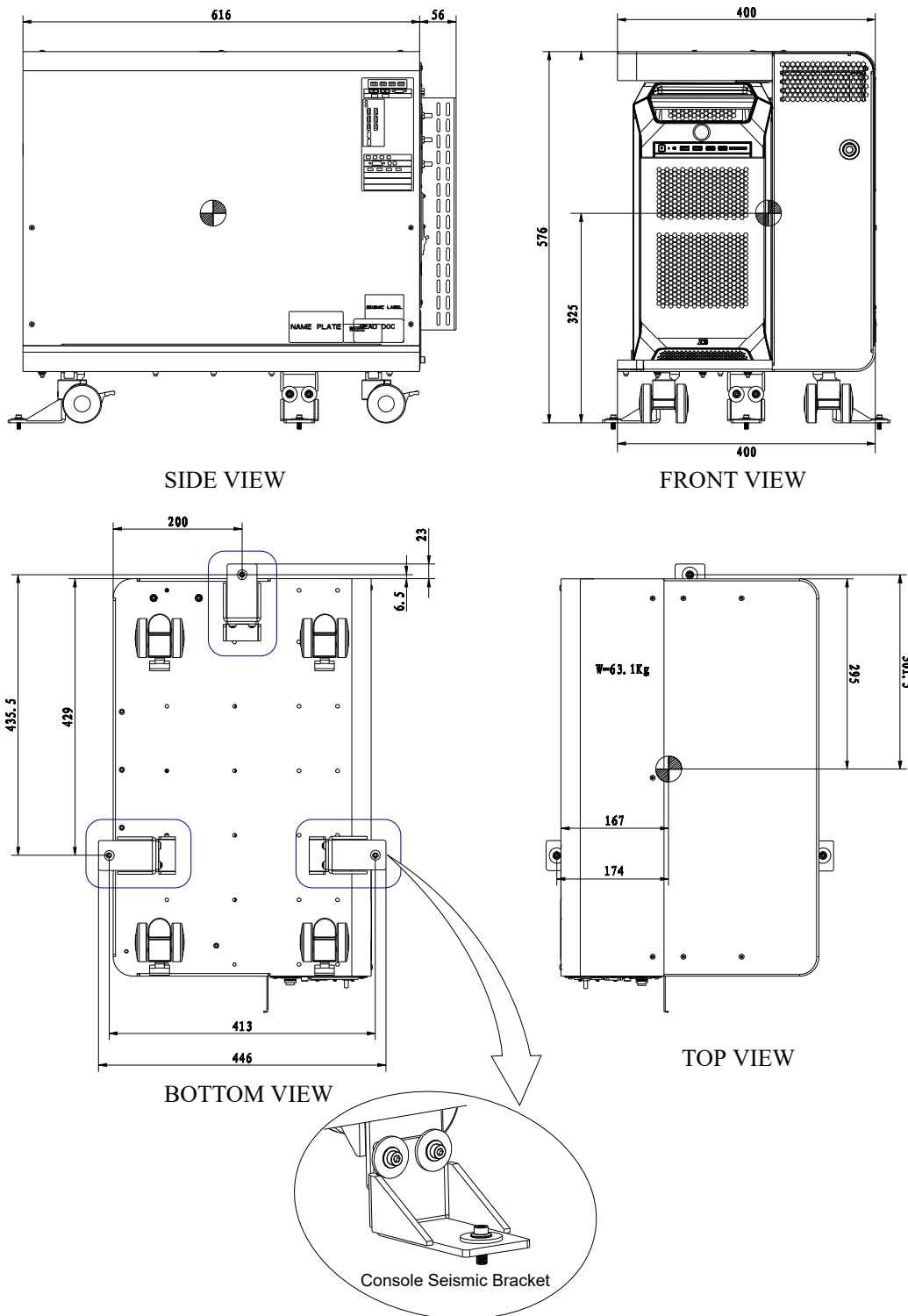
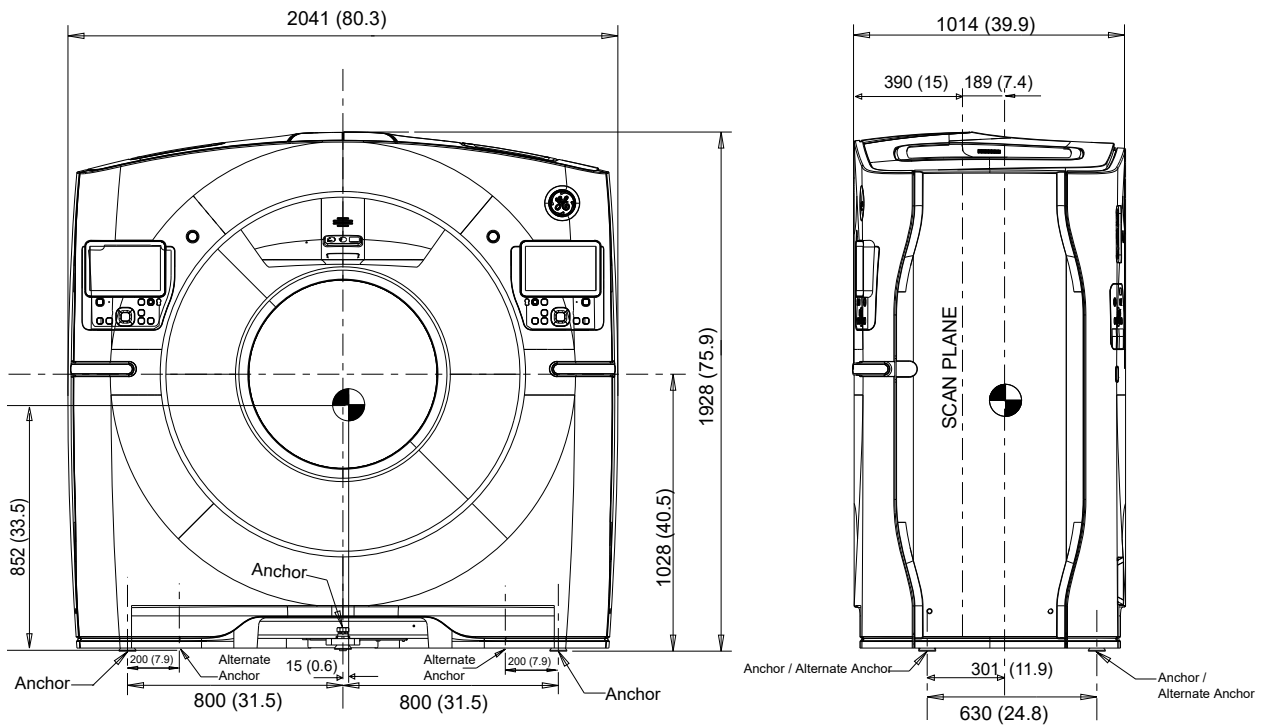

Figure 8-38 Open Console with Z8G5 Center-of-Gravity

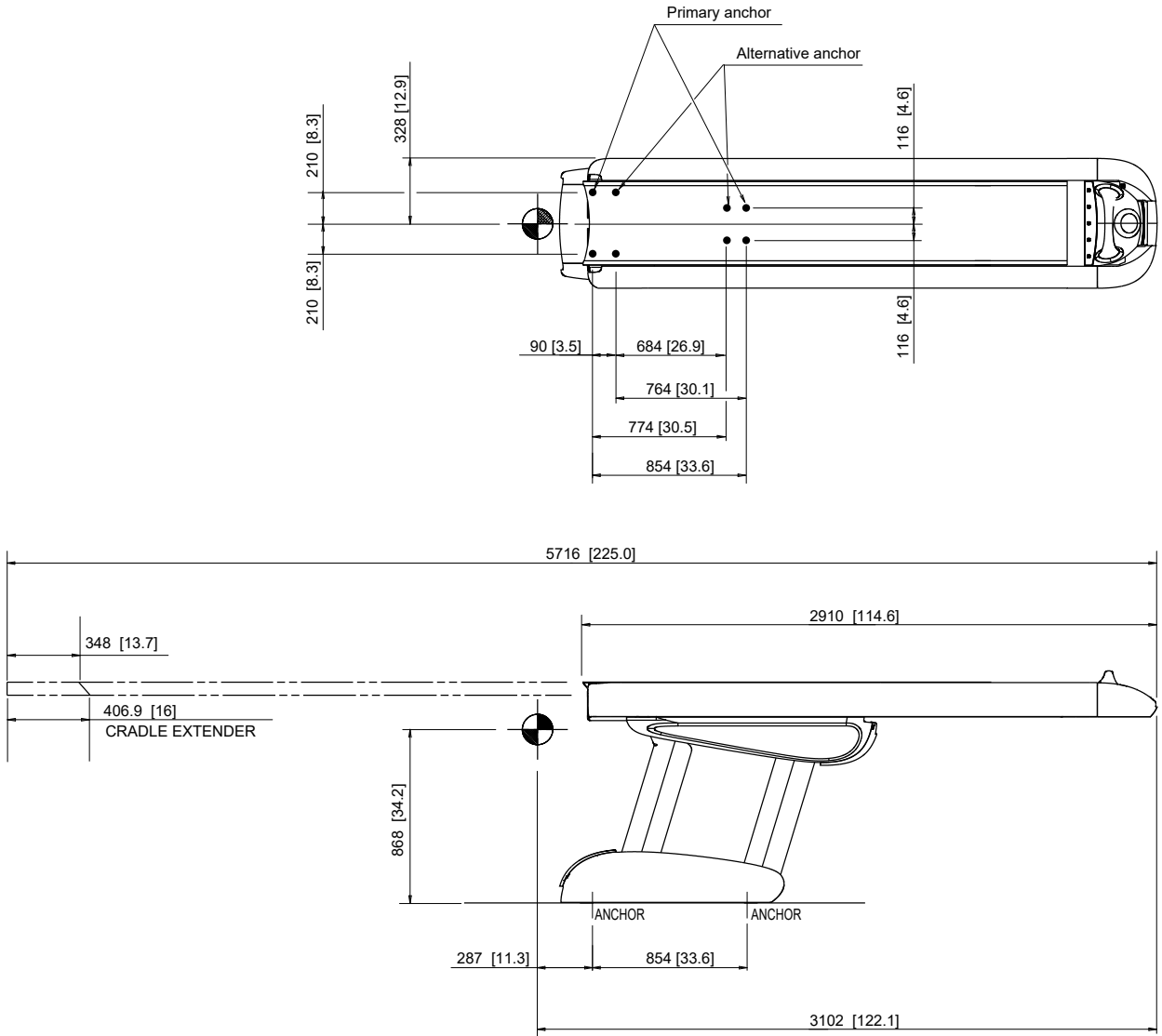

**Figure 8-39 Gantry Center of Gravity**

Unit: mm (in)

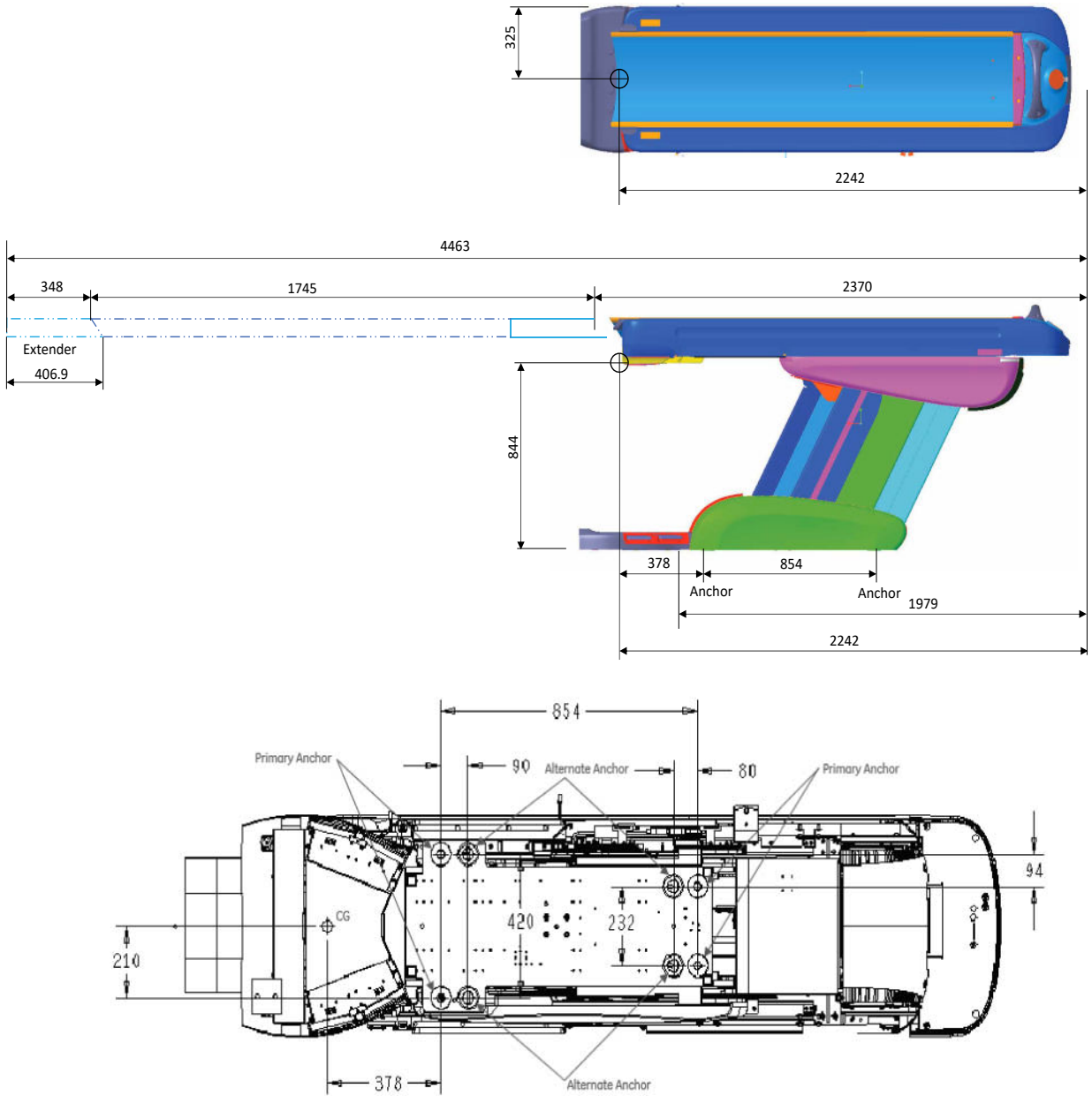

**Figure 8-40 GT2000 Table Center-of-Gravity**



Note: Center of Gravity location marked above includes the mass of a maximum 227kg load capacity on the table with a fully extended cradle.

**Figure 8-41 GT1700V Table Center-of-Gravity**



Note: Center of Gravity location marked above includes the mass of a maximum 227kg load capacity on the table with a fully extended cradle.

**Figure 8-42 Lite Table Center-of-Gravity**

Unit: mm (in)

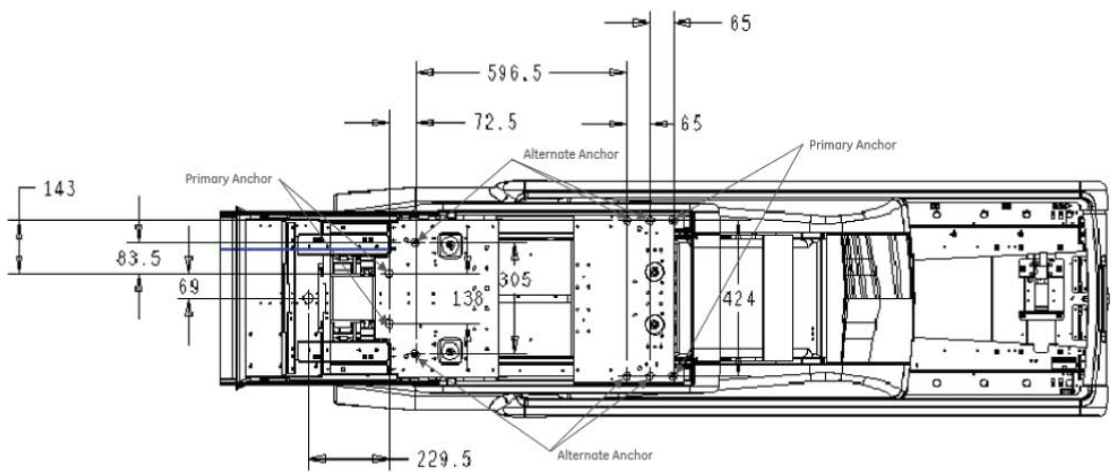
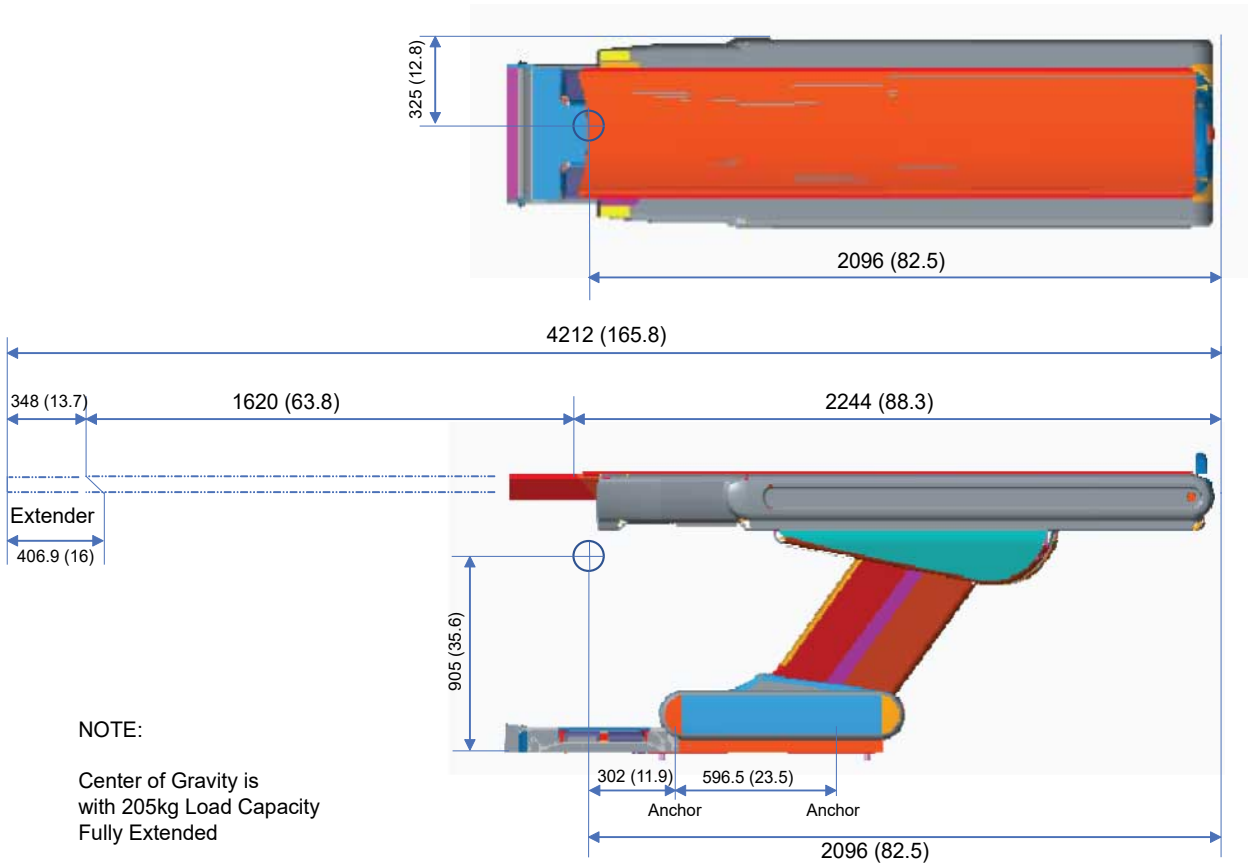

Note: Center of Gravity location marked above includes the mass of a maximum load capacity on the table with a fully extended cradle.

**Figure 8-43 PDU Center of Gravity**

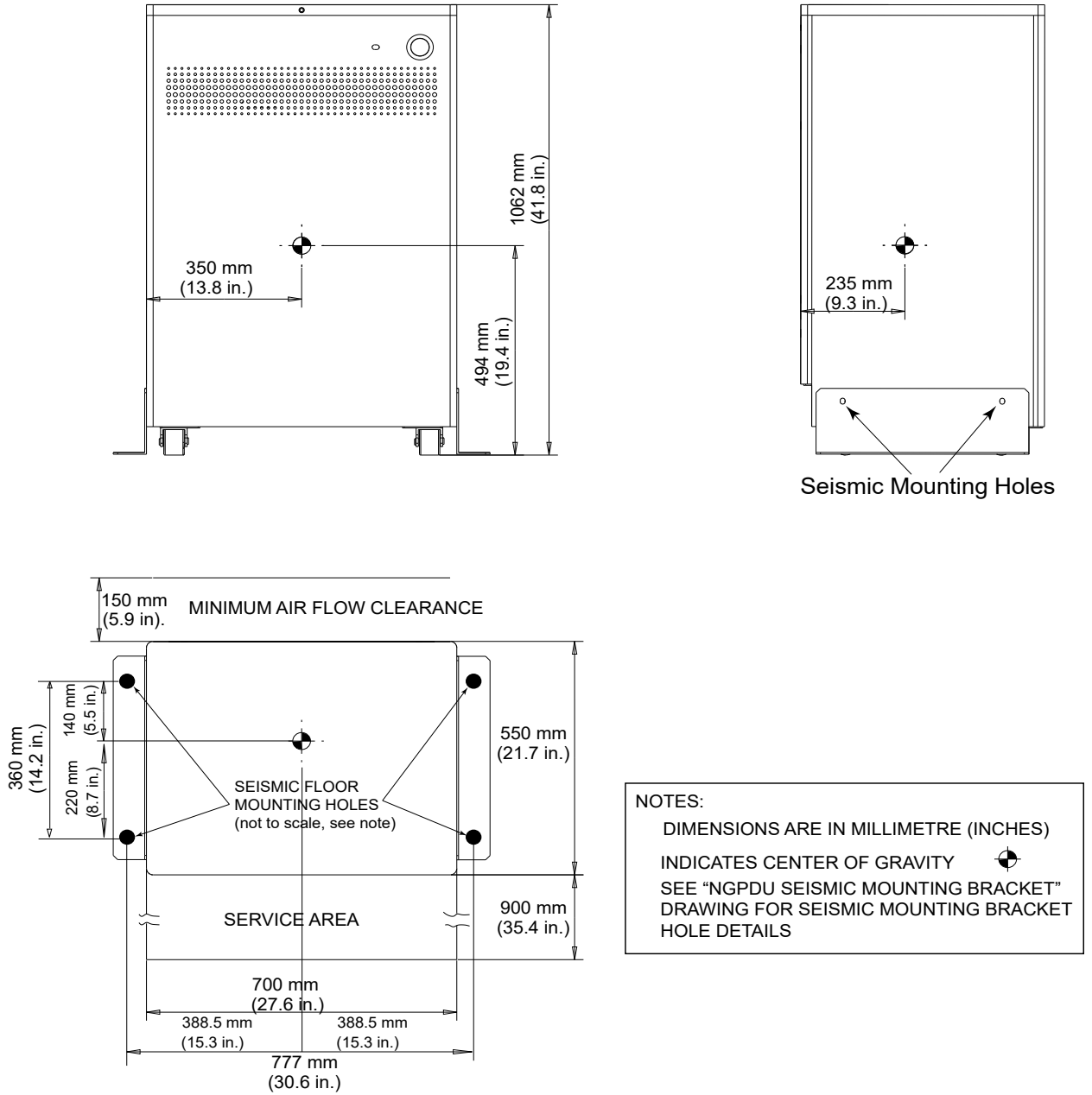

**NOTES:**  
 DIMENSIONS ARE IN MILLIMETRE (INCHES)  
 INDICATES CENTER OF GRAVITY   
 SEE "NGPDU SEISMIC MOUNTING BRACKET"  
 DRAWING FOR SEISMIC MOUNTING BRACKET  
 HOLE DETAILS

## 9 Environmental Requirements

Ensure the operational readiness and proper system calibration of HVAC prior to installation. Maintain the environmental conditions listed below at ALL times, including over nights, weekends, and holidays. Shut down the CT system if air conditioning is not working. When shutting down the system for major repair, you may also shut down the air conditioning.

### 9.1 Temperature and Humidity Specifications

Environmental specifications apply to the table, gantry, power distribution unit, and console.

#### NOTICE

Exceeding environmental specifications may adversely affect system operation and image quality.

#### 9.1.1 Temperature (Scan and Control Rooms)

**Table 9-1 System Temperature Limits**

Maximum allowable ambient room temperature:	26°C (79° F)
Recommended ambient room temperature:	22°C (72°F)
Minimum allowable ambient room temperature:	18°C (64°F)

#### NOTE

Be certain to account for ANY cooling equipment cycle control range, ensuring that the maximum and minimum ambient room temperatures do not exceed those shown in [Table 9-1 System Temperature Limits on page 105](#) during room thermal cycling. For example, if the HVAC is capable of  $\pm 2^{\circ}\text{C}$  control, then the limits would be  $20^{\circ}\text{C} - 24^{\circ}\text{C}$  to maintain absolute limits.

#### 9.1.2 Humidity (Scan Room & Control Room)

**Table 9-2 System Humidity Limits**

Maximum allowable non-condensing relative humidity:	60%
Minimum allowable non-condensing relative humidity:	30%

#### 9.1.3 Other Guidelines

- Accurate determination of hospital room environmental conditions may require the temporary installation of a temperature and humidity recorder near the location designated for system installation. Record temperature and humidity readings before and after installation to verify the site's true environmental conditions.
- Consider heating, ventilating, air conditioning (HVAC) needs, and redundancy (back-up). An air conditioner with two compressor units rather than one, may prevent system downtime. A

redundant (back-up) air conditioner permits CT system operation during an extended repair of the primary air conditioner.

## 9.2 Cooling Requirements

Use [Table 9-3 System Heat Output on page 106](#) to assist in cooling requirements planning. Gantry operation requires over half of the cooling utilized by your system. Contact an HVAC specialist to determine optimal placement of the thermostat and all HVAC vents, bearing in mind that:

- Gantry air INTAKE occurs across the BOTTOM of the gantry.
- Gantry air EXHAUST occurs across the TOP of the gantry.

**Table 9-3 System Heat Output**

System Component	Max BTU/HR	Max Watt
<b>Gantry</b> (See Note 1)	18,700	5,480
<b>Table</b>		
GT1700V Table (1700 mm) / GT2000 Table (2000 mm)	1,030	300
Lite Table (1400 mm)	680	200
<b>Power Distribution Unit</b>	3,400	1,000
<b>Scan Room Subtotal (w/ GT Table)</b>	<b>23,130</b>	<b>6,780</b>
<b>Scan Room Subtotal (w/ Lite Table)</b>	<b>22,780</b>	<b>6,680</b>
<b>Console</b>	2,860	840
LCD Monitor (Total amount of 2 monitors)	340	100
<b>Control Room Subtotal (w/ Z8G4)</b>	<b>3,200</b>	<b>940</b>
<b>System Total (w/ GT Table)</b>	<b>26,330</b>	<b>7,720</b>
<b>System Total (w/ Lite Table)</b>	<b>25,980</b>	<b>7,620</b>
NOTE 1: Maximum heat output reached at tube change (Detailed Calibration).		
NOTE 2: Heat output does not include heat from room lighting, personnel, or non-CT equipment.		

Refer to [Figure 7-1 Gantry with Covers Dimensions on page 47](#), [Figure 7-6 Power Distribution Unit on page 51](#) and [Figure 7-7 Open Console with Z8G4 on page 52](#) for component air flow requirements.

[Figure 9-1 HVAC Air Vent Placement in Scan Room on page 107](#) and [Figure 9-2 HVAC Air Vent Placement in Control Room on page 107](#) show the recommended placements of the thermostat and HVAC vents (intake and output) for the scan and control rooms.

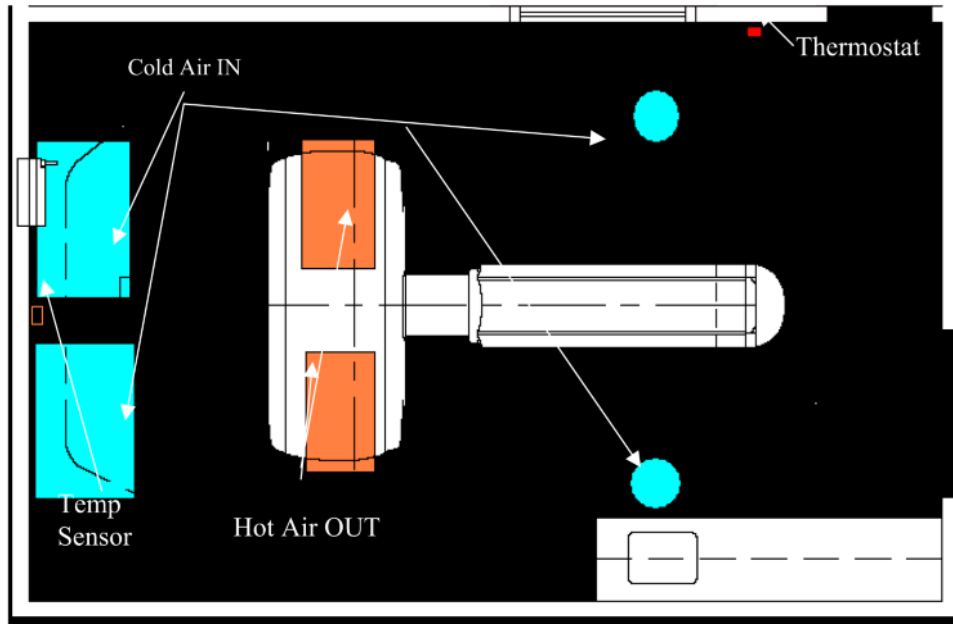
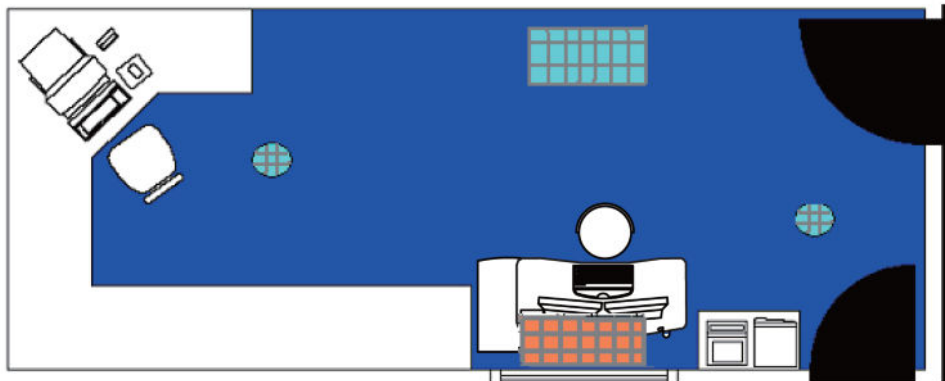
**Figure 9-1 HVAC Air Vent Placement in Scan Room****Figure 9-2 HVAC Air Vent Placement in Control Room**

## 9.3 Altitude

The system shall meet all functional and performance specifications when placed in a room that is at an elevation of -150 m to 2,400 m (-492 ft to 7,875 ft) above sea level.



### NOTE

For sites with altitudes 2,400 m to 3,000 m (7,875 ft to 9842.5 ft), you need a deviation to site at this altitude. Altitudes above 2,400 m (7,875 ft) require engineering approval.

## 9.4 Electro-Magnetic Interference (EMI)

### 9.4.1 Gantry

Locate the gantry in ambient static magnetic fields of less than 0.1 mTesla (1 Gauss) to guarantee the specified imaging performance. Ambient AC magnetic fields must measure below 1  $\mu$ Tesla (10 mGauss) peak.

### 9.4.2 Console / Computer Equipment

Locate computer equipment in ambient static magnetic fields of less than 1 mTesla (10 Gauss) to guarantee data integrity (see [Figure 9-3 Sample Room Layout on page 109](#)).

### 9.4.3 PDU

The PDU produces an electromagnetic field that radiates outward from its cabinet in all directions. Do not place other sensitive electronics around or above the PDU.

### 9.4.4 UPS

The Uninterruptable Power Supply (UPS) provides a consistent power supply to various electrical components of the system. Also, it continues to provide electrical power to components during a site-wide power outage so components can be safely shut down. The UPS should be kept at least one meter (1 m) (3.28 ft.) away from sensitive electronics (the PDU does not include sensitive electronics).

### 9.4.5 EMI Reduction

If you suspect the presence of fields of excessive EMI, consult GE Sales & Service for recommendations. Consider the following when attempting to reduce EMI:

- External field strength decreases rapidly with distance from source of the magnetic field.
- External leakage magnetic field of a three-phase transformer measures much less than that of a bank of three single-phase transformers of an equivalent power rating.
- Large electric motors constitute a source of substantial EMI.
- High-powered radio signals constitute a source of EMI.
- Maintain good screening of cables and cabinets.
- Consider and measure EMI fields of sites with main facility power running UNDER the floor or WITHIN the walls or ceilings of the scan room.
- Pay special attention to power substations and high-voltage power lines in proximity to the scan facility.
- If any concerns remain regarding excessive EMI fields, be sure to measure to confirm that your site meets all required specifications.

## 9.4.6 Equipment EMI "Envelopes"

Figure 9-3 Sample Room Layout

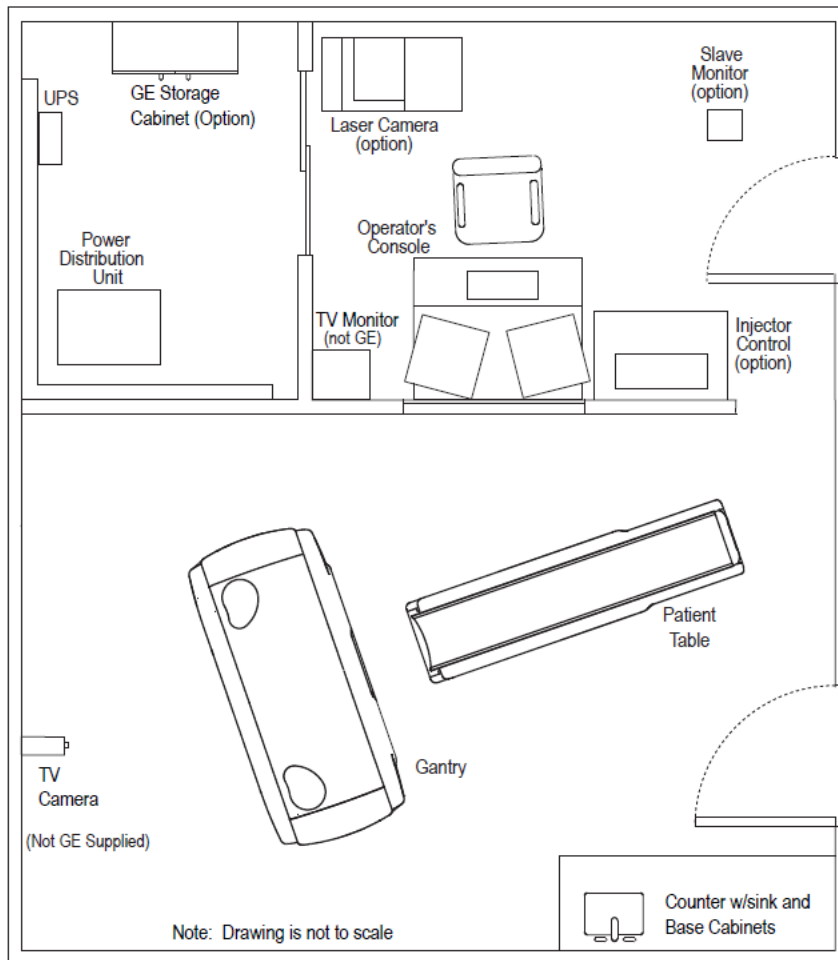

## 9.5 Electro-Magnetic Compatibility (EMC)

### 9.5.1 General Scope

This Revolution Maxima / Revolution Ace (equipment or system for short in the following) complies with IEC 60601-1-2:2007 (Ed3), YY 9706.102:2021 (Ed3 IDT. for China), IEC 60601-1-2:2014 (Ed4.0) and A1:2020 (Ed4.1) EMC standard for medical electrical equipment.

This equipment generates, uses, and can radiate radio frequency energy. The equipment may cause radio frequency interference to other medical and non-medical devices and radio communications.

To provide reasonable protection against such interference, this product complies the radiated emission as per CISPR 11 / GB 4824 Group1 Class A standard limits.

However, there is no guarantee that interference will not occur in a particular installation. If this equipment is found to cause interference (which may be determined by turning the equipment on and off), the user (or qualified service personnel) should attempt to correct the problem by one or more of the following measure(s):

- Reorient or relocate the affected device(s)
- Increase the separation between the equipment and the affected device
- Power the equipment from a source different from that of the affected device
- Consult the point of purchase or service representative for further suggestions

The manufacturer is not responsible for any interference caused by using other than recommended interconnect cables or by unauthorized changes or modifications to this equipment. Unauthorized changes or modifications could void the users' authority to operate the equipment.

The medical staff in charge of this equipment is required to instruct technicians, patients, and other people who may be around this equipment to comply fully with the above equipment. In order to achieve the Electromagnetic Compatibility for a typical installation, further detailed data & requirements are described in the Site Preparation Manual.

The equipment needs special precautions regarding EMC and needs to be installed and put into service according to the EMC information provided in the Pre-Install Manual and Technical Reference Manual.

The equipment is suitable to be used in the electromagnetic environment, as per the limits and recommendations described in the tables hereafter:

- Emission Compliance level and limits ([Table 9-4 Guidance and manufacturer's declaration – electromagnetic emissions on page 111](#)).
- Immunity Compliance level and recommendations to maintain equipment clinical utility ([Table 9-5 Guidance and manufacture's declaration - electromagnetic immunity on page 112](#), [Table 9-6 Guidance and manufacturer's declaration – electromagnetic immunity on page 113](#), [Table 9-7 Recommended separation distances between portable and mobile RF communications equipment and the Equipment on page 114](#) and [Table 9-8 Immunity and recommended separation between RF wireless communication equipment for IEC60601-1-2 Edition 4 on page 115](#)).

**NOTE**

This system complies with above mentioned EMC standard when used with the supplied cables. If different cable lengths are required, contact a qualified GE Service representative for advice.

## 9.5.2 Electromagnetic Emission

**Table 9-4 Guidance and manufacturer's declaration – electromagnetic emissions**

<b>The system is intended for use in the electromagnetic environment specified below. The customer or the user of the system should assure that it is used in such an environment.</b>		
<b>Emissions Test</b>	<b>Compliance</b>	<b>Electromagnetic Environment Guidance</b>
RF emissions CISPR 11 GB 4824	Group 1	The system is suitable for use in all establishments other than domestic and those directly connected to the public low-voltage power supply network that supplies buildings used for domestic purposes.
RF emissions CISPR 11 GB 4824	Class A	
Harmonic emissions IEC 61000-3-2 GB 17625.1	Not applicable	
Voltage fluctuations / flicker emissions IEC 61000-3-3 GB 17625.2	Not applicable	

**NOTE**



GB4824, GB17625.X and GB17626.X standard apply to China only.

**NOTE**





The EMISSIONS characteristics of this equipment make it suitable for use in industrial areas and hospitals (CISPR 11 / GB 4824 class A). If it is used in a residential environment (for which CISPR 11 / GB 4824 class B is normally required), this equipment might not offer adequate protection to radio-frequency communication services. The user might need to take mitigation measures, such as relocating or re-orienting the equipment.

## 9.5.3 Electromagnetic Immunity

**Table 9-5 Guidance and manufacture's declaration - electromagnetic immunity**

<b>The system is intended for use in the electromagnetic environment specified below. The customer or the user of the system should assure that it is used in such an environment.</b>			
<b>Immunity Test</b>	<b>EC 60601 Test Level</b>	<b>Compliance Level</b>	<b>Electromagnetic Environment - Guidance</b>
Electrostatic discharge (ESD) IEC 61000-4-2 GB/T 17626.2	±6 kV contact ±8 kV air ±8 kV contact <sup>a)</sup> ±15 kV air <sup>a)</sup>	±6 kV contact ±8 kV air ±8 kV contact <sup>a)</sup> ±15 kV air <sup>a)</sup>	Floors should be wood, concrete, or ceramic tile. If floors are covered with synthetic material, the relative humidity should be at least 30%.
Electrical fast transient/burst IEC 61000-4-4 GB/T 17626.4	±2 kV for power supply lines ±1 kV for input/output lines	±2 kV for power supply lines ±1 kV for input/output lines	Mains power quality should be that of a typical commercial or hospital environment.
Surge IEC 61000-4-5 GB/T 17626.5	±1 kV line-line ±2 kV line-earth	±1 kV line-line ±2 kV line-earth	Mains power quality should be that of a typical commercial or hospital environment.
Voltage dips, short interruptions and voltage variations on power supply input lines IEC 61000-4-11 GB/T 17626.11	<5 % $U_T$ for 0.5 cycle (>95 % dip in $U_T$ ) 40 % $U_T$ for 5 cycles (60 % dip in $U_T$ ) 70 % $U_T$ for 25 cycles (30 % dip in $U_T$ )	Not applicable	Mains power quality should be that of a typical commercial or hospital environment. If the user of the equipment requires continued operation during power mains interruptions, it is recommended that the equipment be powered from an uninterruptible power supply or a battery.
	<5 % $U_T$ for 5s (>95 % dip in $U_T$ ) 0% $U_T$ , 5s <sup>a)</sup>	<5 % $U_T$ for 5s (>95 % dip in $U_T$ ) 0% $U_T$ , 5s <sup>a)</sup>	
Power frequency (50/60Hz) magnetic fields IEC 61000-4-8 GB/T 17626.8	3 A/m 30 A/m <sup>a)</sup>	3 A/m 30 A/m <sup>a)</sup>	Power frequency magnetic fields should be at levels characteristic of a typical location in a typical commercial or hospital environment.
Proximity Magnetic Fields <sup>a)</sup> IEC 61000-4-39	8 A/m 30 kHz	Not applicable	
	65 A/m 134.2 kHz	65 A/m 134.2 kHz	
	7.5 A/m 13.56 MHz	7.5 A/m 13.56 MHz	
 <b>NOTE</b> $U_T$ is the a.c. mains voltage prior to application of the test level.			
 <b>NOTE</b> <sup>a)</sup> For IEC 60601-1-2:2014 Ed4.0 and A1:2020 Ed4.1, Proximity Magnetic Fields apply to IEC 60601-1-2 Ed4.1 only.			



**Table 9-6 Guidance and manufacturer's declaration – electromagnetic immunity**

The system is intended for use in the electromagnetic environment specified below. The customer or the user of the system should assure that it is used in such an environment.			
Immunity Test	IEC 60601 Test Level	Compliance Level	Electromagnetic Environment - Guidance
<p>Conducted RF IEC 61000-4-6 GB/T 17626.6</p>	<p>3Vrms 150 kHz ~ 80 MHz 6Vrms <sup>a)</sup> ISM bands between 150 kHz and 80 MHz 80%AM at 1kHz</p>	<p>3Vrms 6Vrms <sup>a)</sup> ISM bands between 150 kHz and 80 MHz</p>	<p>Portable and mobile RF communications equipment should be used no closer to any part of the equipment, including cables, than the recommended separation distance calculated from the equation appropriate to the frequency of the transmitter</p> <p><b>Recommended Separation Distance</b></p> $d = 1.2\sqrt{P}$
<p>Radiated RF Fields IEC 61000-4-3 GB/T 17626.3</p>	<p>3V/m 80 MHz ~ 2.5/2.7<sup>a)</sup> GHz 80% AM at 1kHz</p>	<p>3V/m</p>	$d = 1.2\sqrt{P} \quad 80 \text{ MHz} \sim 800 \text{ MHz}$ $d = 2.3\sqrt{P} \quad 800 \text{ MHz} \sim 2.5/2.7^{\text{a)}} \text{ GHz}$ <p>where <i>P</i> is the maximum output power rating of the transmitter in watts (W) according to the transmitter manufacturer and <i>d</i> is the recommended separation distance in meters (m).</p>
<p>Proximity fields from RF Wireless communications equipment <sup>a)</sup> IEC 61000-4-3</p>	<p>refer to <a href="#">Table 9-8 Immunity and recommended separation between RF wireless communication equipment for IEC60601-1-2 Edition 4 on page 115</a></p>	<p>refer to <a href="#">Table 9-8 Immunity and recommended separation between RF wireless communication equipment for IEC60601-1-2 Edition 4 on page 115</a></p>	<p>Field strengths from fixed RF transmitters, as determined by an electromagnetic site survey, <sup>a</sup> should be less than the compliance level in each frequency range.<sup>b</sup></p> <p>Interference may occur in the vicinity of equipment marked with the following symbol:</p> 
<p> <b>NOTE</b> At 80 MHz and 800 MHz, the higher frequency range (6.765 MHz~6.795 MHz , 13.553 MHz~ 13.567 MHz, 26.957 MHz~27.283 MHz, 40.66 MHz~40.70 MHz) applies.</p> <p> <b>NOTE</b> These guidelines may not apply in all situations. Electromagnetic propagation is affected by absorption and reflection from structures, objects, and people.</p> <p> <b>NOTE</b> <sup>a)</sup> For IEC 60601-1-2:2014 Ed4.0 and A1:2020 Ed4.1.</p>			

**Table 9-6 Guidance and manufacturer's declaration – electromagnetic immunity** (Table continued)

<b>The system is intended for use in the electromagnetic environment specified below. The customer or the user of the system should assure that it is used in such an environment.</b>			
<b>Immunity Test</b>	<b>IEC 60601 Test Level</b>	<b>Compliance Level</b>	<b>Electromagnetic Environment - Guidance</b>
<p><sup>a</sup> Field strengths from fixed transmitters, such as base stations for radio (cellular/cordless) telephones and land mobile radios, amateur radio, AM and FM radio broadcast, and TV broadcast cannot be predicted theoretically with accuracy. To assess the electromagnetic environment due to fixed RF transmitters, an electromagnetic site survey should be considered. If the measured field strength in the location in which the equipment is used exceeds the applicable RF compliance level above, the equipment should be observed to verify normal operation. If abnormal performance is observed, additional measures may be necessary, such as re-orienting or relocating the equipment.</p> <p><sup>b</sup> Over the frequency range 150 kHz to 80 MHz, field strengths should be less than 3V/m.</p>			

**Table 9-7 Recommended separation distances between portable and mobile RF communications equipment and the Equipment**

<b>The system is intended for use in an electromagnetic environment in which radiated RF disturbances are controlled. The customer or the user of the system can help prevent electromagnetic Interference by maintaining a minimum distance between portable and mobile RF communications equipment (transmitters) and the system as recommended below, according to the maximum output power of the communications equipment</b>			
<b>Rated Maximum Output Power (P) of Transmitter (W)</b>	<b>Separation Distance according to Frequency of Transmitter</b>		
	<b>150 kHz ~ 80 MHz</b> $d = 1.2\sqrt{p}$	<b>80 MHz ~ 800 MHz</b> $d = 1.2\sqrt{p}$	<b>800 MHz ~ 2.5/2.7<sup>a</sup> GHz</b> $d = 2.3\sqrt{p}$
0.01	0.12	0.12	0.23
0.1	0.38	0.38	0.74
1	1.2	1.2	2.3
10	3.8	3.8	7.3
100	12	12	23
<p>For transmitters rated at a maximum output power not listed above, the separation distance can be estimated using the equation in the corresponding column, where P is the maximum output power rating of the transmitter in watts (W) according to the transmitter manufacturer.</p> <p><b>NOTE</b>  At 80 MHz and 800 MHz, the separation distance for the higher frequency range applies.</p> <p><b>NOTE</b>  These guidelines may not apply in all situations. Electromagnetic propagation is affected by absorption and reflection from structures, objects, and people.</p> <p><b>NOTE</b>  <sup>a)</sup> For IEC 60601-1-2:2014 Ed4.0 and A1:2020 Ed4.1.</p>			

**⚠ WARNING**



PORTABLE RF COMMUNICATIONS EQUIPMENT (INCLUDING PERIPHERALS SUCH AS ANTENNA CABLES AND EXTERNAL ANTENNAS) SHOULD BE USED NO CLOSER THAN 30 CM (12 INCHES) TO ANY PART OF THE SYSTEM, INCLUDING CABLES SPECIFIED BY THE MANUFACTURER. OTHERWISE, DEGRADATION OF THE PERFORMANCE OF THIS EQUIPMENT COULD RESULT.

**Table 9-8 Immunity and recommended separation between RF wireless communication equipment for IEC60601-1-2 Edition 4**

**Portable RF communications equipment (including peripherals such as antenna cables and external antennas) at frequencies noted below should be used no closer than 30cm (12 inches) to any part of the system, including cables specified by the manufacturer. Otherwise, degradation of the performance of this equipment could result.**

**Minimum separation distances for higher IMMUNITY TEST LEVELS shall be calculated using the following equation:**

$$d = \left[ \frac{6}{E} \right] \sqrt{P}$$

**Where *P* is the maximum power in W, *d* is the minimum separation distance in m, and *E* is the IMMUNITY TEST LEVEL in V/m.**

Test frequency (MHz)	Band (MHz)	Service	Maximum power (W)	IMMUNITY TEST LEVEL (V/m)
385	380 - 390	TETRA 400	1.8	27
450	430 - 470	GMRS 460 FRS 460	2	28
710	704 - 787	LTE Band 13, 17	0.2	9
745				
780				
810	800 - 960	GSM 800/900 TETRA 800 iDEN 820 CDMA 850 LTE Band 5	2	28
870				
930				
1720	1700 - 1990	GSM 1800 CDMA 1900 GSM 1900 DECT LTE Band 1, 3, 4, 25 UMTS	2	28
1845				
1970				
2450	2400 - 2570	Bluetooth, WLAN 802.11 b/g/n RFID 2450 LTE Band 7	2	28

**Table 9-8 Immunity and recommended separation between RF wireless communication equipment for IEC60601-1-2 Edition 4 (Table continued)**

<p><b>Portable RF communications equipment (including peripherals such as antenna cables and external antennas) at frequencies noted below should be used no closer than 30cm (12 inches) to any part of the system, including cables specified by the manufacturer. Otherwise, degradation of the performance of this equipment could result.</b></p> <p><b>Minimum separation distances for higher IMMUNITY TEST LEVELS shall be calculated using the following equation:</b></p> $d = \left[ \frac{6}{E} \right] \sqrt{P}$ <p><b>Where <math>P</math> is the maximum power in W, <math>d</math> is the minimum separation distance in m, and <math>E</math> is the IMMUNITY TEST LEVEL in V/m.</b></p>				
Test frequency (MHz)	Band (MHz)	Service	Maximum power (W)	IMMUNITY TEST LEVEL (V/m)
5240	5100 - 5800	WLAN 802.11 a/n	0.2	9
5500				
5785				

### 9.5.4 Use Limitation

The scanner is intended for use only by trained professionals who must be trained in CT system operation and has sufficient knowledge of radiation, scan setting, image annotation and review, the operator shall understand the operation and expected performance of the system per training and reading of the operator manual and technical reference manual.

The scanner is expected to be able to position patient, scan, display or output images with annotation and without artifact or noise that emulate or hide pathology, timely and accordingly. Test per chapter Quality Assurance to ensure scanner performance as expectation, Daily preparation procedure and calibration shall be used to maintain scanner performance and prevent failure or degradation before use. Contact GE service if any failure.

The table below described some possible failure or degradation of performance need to check before further use.

**Table 9-9 Performance Failure and Detection**

Function	Performance Failure and Detection	Instruction to Check or Maintain
Patient positioning	Unintended motion or positioning	Manual check table positioning or positioning patient successfully during scan
Scan	Unintended scan exposure	Check scan control button response as expected Daily prepare or Test per Quality Assurance
Image annotation	Unintended image annotation or scan setting	Complete patient information and scan settings accordingly before scan, ensure keyboard and display response as expected
Display and output	Unexpected display or output, not available for visual check or diagnose	Daily prepare or test per Quality Assurance, ensure scan recon setting, display and printer function as expected

**Table 9-9 Performance Failure and Detection** (Table continued)

Function	Performance Failure and Detection	Instruction to Check or Maintain
IQ/artifact	Unexpected artifact or noise that emulate or hide pathology	Daily prepare or test per Quality Assurance, ensure Image Quality according with spec. Verify CT# for air, water and object scanned for doubts in the image
Image delay	Unexpected scan image time delay	Daily prepare or test per Quality Assurance, verify scan and recon setting

The system should be installed, maintained and used per guidance in EMC section for safety and expected performance. To use per guidance, separate from other device sensitive or with EM disturbance will help to maintain the performance of the scanner and other device.

 **WARNING**



This system is intended for use by healthcare professionals only. This system may cause radio interference or may disrupt the operation of nearby equipment. It may be necessary to take mitigation measures, such as reorienting or relocating the system or shielding the location.

 **WARNING**



CT Scans may cause interference with implanted or externally worn electronic medical devices such as pacemakers, defibrillators, neuro stimulators and drug infusion pumps. The interference could cause operational changes or malfunction of the electronic medical device.

Use of RF (Radio Frequency) sources that intentionally transmit, such as cellular telephones, transceivers, radio-controlled products, or other RF emitting equipment may cause performance outside the systems published specifications or other adverse operation. Keep the power to these RF sources turned off when near this equipment. Recommended separation distances and information regarding compatibility with other equipment are located in the Manufacturer's EMC Declaration Tables.

Operation of the accessories like EKG monitor and respiratory gating device below the manufacturer specified minimum amplitude or value of patient physiological signals may cause inaccurate results.

Only transducers and cables GE specified can be replacement parts for internal components, details of components and cables refer to Pre-Installation Manual.

The use of accessories, transducers, and cables other than those specified in GE Approved Accessories may result in increased emissions or decreased immunity performance of the equipment.

 **WARNING**



Use of accessories, transducers and cables other than those specified or provided by the manufacturer of this equipment could result in increased electromagnetic emissions or decreased electromagnetic immunity of this equipment and result in improper operation.

## 9.5.5 Installation Requirements and Environment Control

In order to minimize interference risks, the following requirements apply.

### 9.5.5.1 Environment of Intended Use

This medical device is evaluated to the IEC60601-1-2 safety standard electromagnetic emissions and immunity levels in the Professional Healthcare Facility environment category, predominantly for use in hospital except for near active HF SURGICAL EQUIPMENT or SHORT-WAVE THERAPY EQUIPMENT with a dedicated supply system, and with an X-ray shielded room. The equipment is not directly connected to the Public Mains Network.

The CT System is exposed to EM sources generally from LAN and WLAN, mobile phones, paging systems, computers, printers, monitors, and other medical devices. See sections in this manual for the electromagnetic disturbance compliance levels this product meets including a list of wireless communications services evaluated.

This medical device is not suitable for use in certain hospital environments. Electrical devices that are brought into the CT System room that generate intense EM disturbances have not been considered per the safety standard. Also, the CT System compliance levels don't guarantee that other equipment in the room that is EM sensitive is not impacted. The IEC60601-1-2 safety standard requires additional testing and/or risk assessment for compliance and patient/operator safety of the CT system.

**Table 9-10 Environment of Intended Use**

<b>Environment of Intended Use</b>	
This medical device is evaluated to the IEC60601-1-2 safety standard electromagnetic emissions and immunity levels in the environment category shown below.	
<b>ENVIRONMENT CATEGORY</b>	<b>EXAMPLES</b>
Professional Healthcare Facility	EM sources generally are from LAN and WLAN, mobile phones, paging systems, IT equipment, medical devices. Physician Offices / Clinics / Limited Care Facilities / Freestanding Surgical Centers / Multiple Treatment Facilities / Hospitals / Trailer connected to Hospital power (for CT mobile qualified)
<b>Environment Exclusions</b>	
This medical device may not be suitable for use in the IEC60601-1-2 safety standard environment categories listed below. The types of electromagnetic disturbances emitted from electrical devices found in these environments and their effect on the performance of this medical device have not been considered per the safety standard. The safety standard requires additional testing and/or risk assessment for compliance and patient/operator safety of the CT system.	
<b>ENVIRONMENT CATEGORY</b>	<b>EXAMPLES</b>
Home Healthcare Environment	Locations that have diverse electromagnetic disturbances. Category includes transportation. Residences / Homes / Nursing Homes / Vehicles (Cars, Trains, Planes) / Mobile Emergency Medical Services / Airports / Outdoors
Special Environment – Medical	EM sensitive locations or sources of intense emissions. Rooms with HF surgical equipment / Rooms with short-wave therapy equipment / Inside RF shielded room of an MRI system.
Special Environment - Military	Unique locations that have not been EM characterized. Near Radar Installations / Near Weapons Control Systems

**Table 9-10 Environment of Intended Use** (Table continued)

Environment of Intended Use	
Special Environment – Industrial	Unique locations that have not been EM characterized. Power Plants / Manufacturing Facilities / Mining / Refineries / Mills

### 9.5.5.2 Cable Shielding and Grounding

All interconnect cables to peripheral devices must be shielded and properly grounded. Use of cables not properly shielded and grounded may result in the equipment causing radio frequency interference.

### 9.5.5.3 Subsystem & Accessories Power Supply Distribution

All components, accessories subsystems, systems which are electrically connected to the system, must have all AC power supplied by the same power distribution panel & line.

### 9.5.5.4 Stacked Components & Equipment

System should not be used adjacent to or stacked with other equipment; if adjacent or stacked use is necessary, System should be observed in order to verify normal operation in the configuration in which it will be used.



Use of this equipment adjacent to or stacked with other equipment should be avoided because it could result in improper operation. If such use is necessary, this equipment and the other equipment should be observed to verify that they are operating normally.

### 9.5.5.5 Low Frequency Magnetic Field

In case of a digital System, the Gantry (digital detector) shall be apart 1 meter from the generator cabinet, and 1 meter apart from the analog (CRT) monitors. These distance specifications will minimize the low frequency magnetic field interference risk.

### 9.5.5.6 Static Magnetic Field Limit

In order to avoid interference on system, static field limits from the surrounding environment are specified.

- Static field is specified less than <1 Gauss in Examination room, and in the Control Area.
- Static field is specified less than <3 Gauss in the Technical Room.

### 9.5.5.7 Electrostatic Discharge Environment & Recommendations

In order to reduce electrostatic discharge interference, install a charge dissipative floor material to avoid electrostatic charge buildup.

The relative humidity shall be at least 30 percent.

The dissipative material shall be connected to the system ground reference, if applicable.

## 9.6 System Component Noise Levels

**Maximum Gantry Audible Noise Level** The maximum ambient noise level is produced by the gantry during a CT scan acquisition. It is less than 70dBA when measured at a distance of one meter from the nearest gantry surface, in any direction.

**Maximum Console Audible Noise Level** The maximum ambient noise levels is less than or equal to 54dBA when measured 1m up and 1m away from the console at an ambient temperature of 26°C.

# 10 Radiation Protection Requirements

## 10.1 Shielding Requirements

### NOTICE

Engage a QUALIFIED RADIOLOGICAL HEALTH PHYSICIST to review your scan room shielding requirements, taking into consideration:

- **Scatter radiation levels within the scanning room (see Figure 10-1 Typical Scatter Survey (Large Filter (Body) - Phantom 32cm CTDI) on page 123 and Figure 10-2 Typical Scatter Survey (Small Filter (Heal) - Phantom 16cm CTDI) on page 124).**
- **Equipment placement.**
- **Weekly projected work-loads (number of patients/day technique (kvp\*ma))**
- **Materials used for construction of walls, floors, ceiling, doors, and windows.**
- **Activities in surrounding scan room areas.**
- **Equipment in surrounding scan room areas (e.g., film developer, film storage)**
- **Room size and equipment placement within the room relative to room size.**

The illustrations in this Chapter depict measured radiation levels within the scanning room, while scanning a 32 cm or 16 cm CTDI phantom with the technique shown. Use the mAs, kV and aperture scaling factors shown in [Table 10-1 Shielding Requirements Scaling on page 121](#) to adjust exposure levels to the scan technique used at the site. The exposure level for a 120 kV, 800 mA, 1 sec. scan at 1270 mm (50 in.) away from the scan plane is:  $10.4 \mu\text{Gy} \times 0.71 \times 800/100 = 59.2 \mu\text{Gy}$ .

### NOTE

Actual measurements can vary. Expected deviation equals  $\pm 15\%$ , except for the 5 mA and 1 mm techniques, where variation may be greater (up to a factor of 2), due to the inherent deviation in small values. The maximum deviation anticipated for tube output equals  $\pm 40\%$ .

**Table 10-1 Shielding Requirements Scaling**

Changed Parameter	Multiplication Factor
mAs	new mAs/100
80 kV	0.24
100 kV	0.45
120 kV	0.71
140 kV	1.00
1mm aperture	0.20
3 mm aperture	0.22
5 mm aperture	0.27

**Table 10-1 Shielding Requirements Scaling** (Table continued)

Changed Parameter	Multiplication Factor
10 mm aperture	0.38
15 mm aperture	0.48
20 mm aperture	0.59
30 mm aperture	0.79
40 mm aperture	1.00

**NOTICE**

**This publication uses  $\mu\text{Gy}$  (micrograys) to measure radiation levels. The conversion factor from mR to  $\mu\text{Gy}$  (micrograys) is:  $1 \text{ mR} = 8.76 \mu\text{Gy}$ .**

**Figure 10-1 Typical Scatter Survey (Large Filter (Body) - Phantom 32cm CTDI)**

**NOTE:** The 32cm CTDI Phantom should be placed on the patient table.

ISO-Contour 1.3, 2.6, 5.2, and 10.4  $\mu$  Gray/scan Technique 140kV, 100mA, 1second(s), 40mm

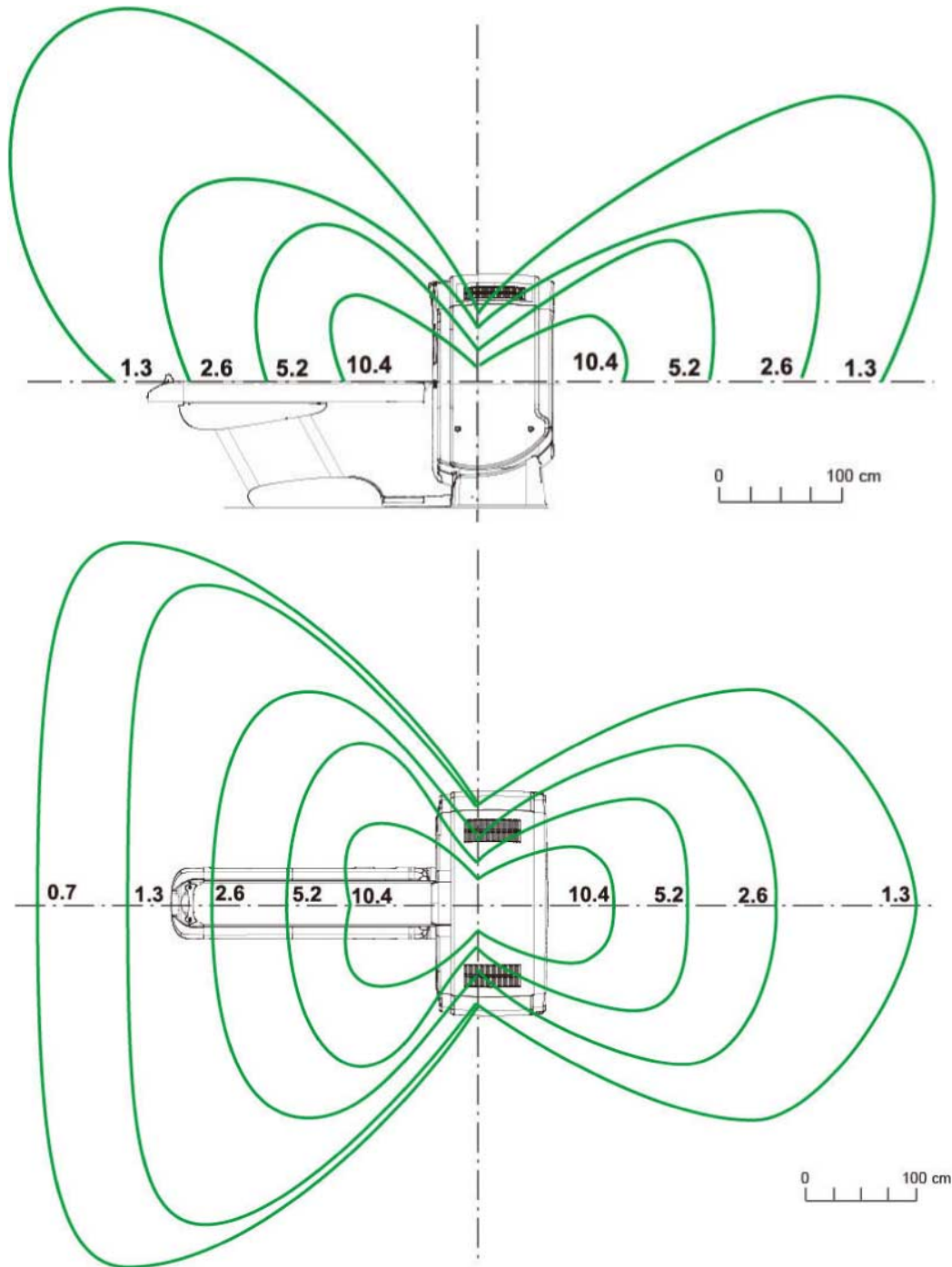

**Figure 10-2 Typical Scatter Survey (Small Filter (Heal) - Phantom 16cm CTDI)**

**NOTE:** The 16cm CTDI Phantom should be placed on the patient table.

ISO-Contour 0.7, 1.3, 2.6, and 5.2  $\mu$  Gray/scan Technique 140kV, 100mA, 1second(s), 40mm

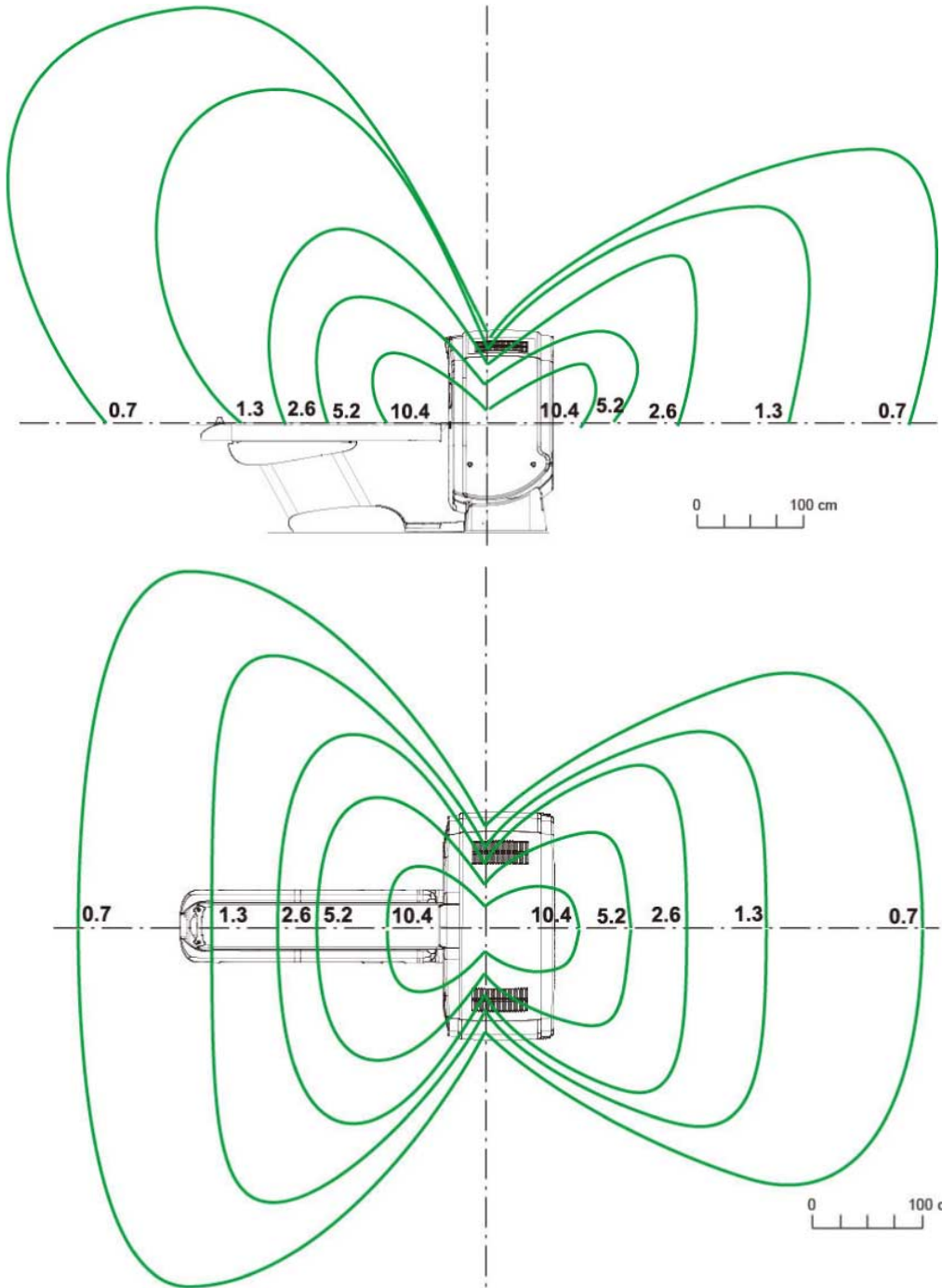

# 11 Network Requirements

## 11.1 Network Connections

The network requirements listed in this chapter should allow you to connect the system to:

- Hospital/facility networks
- Filming cameras
- PACS
- Workstations
- Patient Information Systems

### 11.1.1 Network Type

The systems require a broadband network connection.

### 11.1.2 Network Speed

The customer and the customer's IT contact should ensure that the site provides access to broadband using one of the following interface types:

- 100BASE-TX (100 Mbit/s)
- 1000BASE-T (1000 Mbit/s [1 Gbit/s]).

### 11.1.3 Network Cable Routing

The CT system connects to the facility's network through the console. To enable proper network cabling, the customer and the customer's IT contact should:

- Provide an RJ45 wall outlet within 2 m (79 in.) of the console location.
- Provide a patch cable, not to exceed 3.05 m (10 ft), to connect the console to a wall box. (See Notes on [Figure 13-2 Interconnection Runs on page 150](#))
- Complete any cable duct-work or conduit installation that the customer site-unit might require to route connecting network cables to the workstation, camera, and console.
- Ensure that the run from the hospital/facility switch to the CT wall outlet does not exceed 88 m (290 ft). Bandwidth performance degrades significantly when the length exceeds 91 m (300 ft).
- Use of STP (Shielded Twisted Pair) cable is not allowed.

## 11.2 Customer Broadband Responsibilities

### 11.2.1 Contact GE to Find Zone Broadband Specialist

Contact your GE PMI to obtain the name of the zone broadband specialist who will:

- Work with the Customer Champion to complete any identified infrastructure changes.
- Provide IP addresses for new CT equipment.
- Provide a VPN compatible appliance that will support the IPSec tunneling protocol and 3DES data encryption.
- Utilize an Internet Service Provider that supports static routing.

### 11.2.2 Provide GE with IT Contact Information for the Site

Provide your GE PMI with an accurate site address, telephone number, contact name, and e-mail address for the customer IT contact who will:

- Coordinate VPN activities between Radiology/Cardiology and the Information Technology (IT) departments.
- Act as a focal point in assuring site broadband infrastructure meets GE requirements for connection, as determined by a mutual assessment with the GE connectivity team.
- Complete an equipment assessment with the GE connectivity team to determine site readiness for broadband.

## 11.3 Digital Service and Connectivity Requirements

### 11.3.1 Background

GE Healthcare provides digital service and asset management through its InSite Connectivity Platform.

InSite RSvP (Remote Service Platform) is the latest connectivity platform that will eventually replace the existing InSite 1 connectivity infrastructure in the system.

GE can proactively monitor the key operational parameters of your medical systems to provide early warning of potential issues to head off costly and unscheduled downtime. The GE online engineers can recalibrate key operational parameters to help ensure optimal system performance or can dispatch a field engineer to assist in mitigating the issue. Additionally, automated software downloads require reliable connectivity platform to ensure software updates and upgrades in a timely manner to keep the system working efficiently. Software downloads also significantly reduce the time it takes to upgrade your GE Healthcare devices, which means the scheduled system downtime and clinical workflow interruptions are greatly reduced.

The two major technical components of InSite RSvP are Agent and Server. The Agent is installed on the GE Healthcare equipment at the customer sites while the Server resides within GE Healthcare. The role of the Agent is to:

- monitor device performance data on an ongoing basis,
- establish secure communications to the Server via the Internet,

- and send fault information and log files to the Server

The Server uses the secure Web Services to communicate with the Agent. It processes the performance and fault information provided by the Agent.

## 11.3.2 InSite RSVP Connectivity Requirements

The Agent establishes connectivity from behind the safety of your corporate firewall, adhering to all the security policies set up by your network administrators. To your network, the Agent is just another computer on the LAN. To set up the InSite 2.0 Agent at your site, the only networking requirements are as follows:

1. A physical connection or a route to an existing enterprise LAN
2. Allow outbound Internet access for the device using HTTPS protocol over port 443

A GE Healthcare Field Engineer will configure network connections for InSite RSVP connectivity according to the site IT requirements.

Customer IT personal would need to ensure the following details to enable connectivity at install:

1. DNS IP Address or Proxy IP address and authentication information as applicable is made available when requested by the GE Field Engineer or Project manager of Installation
2. In case it is required to whitelist, only certain URLs being used by GE Healthcare, here is a list that could be used:
  - 2.1. Enterprise production: <https://insite.gehealthcare.com:443>
  - 2.2. Flexera URL: <https://gehealthcare-ns.flexnetoperations.com>

InSite RSVP utilizes existing the outbound broadband internet connection. It uses the Secure Sockets Layer (SSL) and complies with the existing firewall rules and Web proxies. Once the Agent has established a secure tunnel, the connection is visible only to InSite RSVP clients and services (applications or users)



### NOTE

For GE HealthCare Personnel only:

1. If a customer is not able to provide the internet connection then GE HealthCare needs to provide the internet connection along with the required router device.
2. If a customer has GE HealthCare provided internet connection or has GE HealthCare provided router device running on the customer provided internet connection then consult the customer if the same set is to be used.

Page intentionally left blank

## 12 Power Requirements

Be sure to communicate all necessary information in this chapter to the electrical contractor employed at the installation site.

### 12.1 Introduction

#### NOTICE

Be sure to communicate all necessary information in this chapter to the electrical contractor employed at the installation site.

The Power Distribution Unit (PDU) supplied with the system transforms and distributes power to all system components. The PDU constitutes the only power entry point required to operate the system. To minimize voltage regulation effects, keep power wiring between the facility main distribution panel and the PDU as short as possible.

When routing the power wiring, all three-phase wires and ground must run in the same conduit or raceway duct. Route power wires separate from the system control and signal cables, using a separate conduit or trough in a raceway duct. You may use a metallic conduit, floor duct, or surface raceway for running cables, depending upon local codes and practices. However, ensure that cable passageways are large enough to install additional cables with all other cables already installed. Do not use non-metallic conduit.

### 12.2 System Input Power

#### 12.2.1 Power Source Configuration

The system operates on a three-phase, solidly grounded four-wire wye or Delta power source. The neutral wire does not need to run to the system, (i.e., four-wire connection). If you are running a NEUTRAL wire, terminate it in the A1/MDP box.

A dedicated feeder from the nearest Main Distribution Panel (MDP) should supply power to the system. In accordance with the National Electric Code (U.S.) and similar applicable national and local codes, the site MUST provide a protective disconnect device with LOCK-OUT and TAG-OUT provisions in the power line supplying the PDU, and MUST locate the protective disconnect device within 10 m (32 ft) of the PDU, visible to PDU service personnel. The disconnect device appears as A1/MDP in the interconnection schematic diagrams.

#### 12.2.2 Rating

The system operates on three-phase power that meets the following specifications:

##### **For 100kVA (72kW peak)**

- Voltage: 200 to 240VAC, 380 to 480 VAC
- Capacity: 100 kVA
- Frequency: 50 or 60 Hz  $\pm$  3 Hz

- Maximum power demand = 100 kVA @ 0.85 PF at a selected technique of 140 kV, 515 mA.
- Average effective (RMS) power demand at maximum duty cycle = 20 kVA.
- Idle power demand (without rotation and X-ray) = 5 kVA.

**For 75kVA (55.3kW peak)**

- Voltage: 200 to 240VAC, 380 to 480 VAC
- Capacity: 75 kVA
- Frequency: 50 or 60 Hz  $\pm$  3 Hz
- Maximum power demand = 75 kVA @ 0.85 PF at a selected technique of 120 kV, 460 mA.
- Average effective (RMS) power demand at maximum duty cycle = 20 kVA.
- Idle power demand (without rotation and X-ray) = 5 kVA.

**For 50kVA (33.6kW peak)**

- Voltage: 200 to 240VAC, 380 to 480 VAC
- Capacity: 50 kVA
- Frequency: 50 or 60 Hz  $\pm$  3 Hz
- Maximum power demand = 50 kVA @ 0.85 PF at a selected technique of 120 kV, 280 mA.
- Average effective (RMS) power demand at maximum duty cycle = 20 kVA.
- Idle power demand (without rotation and X-ray) = 5 kVA.

The A1/MDP disconnect device referenced above must provide overcurrent protection for the system and have at least one Emergency Off switch within the scan suite, near the console. The preferred disconnect utilizes undervoltage release control, rather than shunt trip devices. The rating of the A1/MDP disconnect device depends on the nominal line voltage at the site. Refer to [12.3 Recommended Power Distribution System on page 131](#) for minimum rating requirements and suggested disconnect devices.

## 12.2.3 Regulation

Total load regulation, as measured at the PDU input terminals, must not exceed 6%. The capacity of the facility transformer and size and length of feeder wires directly affect the load regulation presented to the system. Refer to [12.3 Recommended Power Distribution System on page 131](#), for recommended single-unit installation specifics.

## 12.2.4 Phase Imbalance

The difference between the highest line-to-line voltage and lowest line-to-line voltage must not exceed 2% of the lowest line-to-line voltage.

## 12.2.5 Sags, Surges and Transients

Sags and surges of the power line must not exceed the absolute range limits shown in [12.3.3 System Power Requirements on page 132](#). Limit maximum transient voltages to 1500 V peak.

## 12.2.6 Grounding

The customer's electrician needs to perform the following tasks:

- Bond metal conduit, raceway, or the armor of armored cable used to power the system to the PDU cabinet and to the A1/MDP Disconnect
- Run a dedicated 1/0 (50 mm<sup>2</sup>) or larger insulated copper ground wire from the main distribution panel to the PDU with the phase wires.
- Run the ground wire with the three-phase wires from the power source to the A1/MDP Disconnect and from A1/MDP Disconnect to the PDU. Grounding does not require a neutral wire.

**NOTE**

The shield or armor of armored cable ALONE does NOT provide sufficient grounding.

Bond the ground wire to the intermediate distribution panels through which it passes in accordance with local codes. The resistance between the PDU ground and the facility earth ground must not exceed 0.5 ohm. In addition, the total resistance between the PDU ground and earth must not exceed 2 ohms. In addition:

- The facility ground for the CT system must originate at the system power source (i.e., transformer or first access point of power into the facility) and be continuous to the CT system A1/MDP Disconnect in the room.
- Main facility ground conductor to A1/MDP Disconnect must be appropriately sized insulated copper wire.
- Run a dedicated 1/0 (50 mm<sup>2</sup>) or larger insulated copper ground wire from A1/MDP to PDU. The main facility ground to the A1/MDP Disconnect must meet local codes, in all cases the recommended ground wire is a 1/0 (50 mm<sup>2</sup>) ground wire.

## 12.2.7 Potential Equalization Conductor (Reference IEC 60601-1-2 2007; 2014; 2020)

The voltage of a conductor or body to earth is called the “potential” of this conductor or body. The earth is electrically neutral and thus has the potential “zero”. The unit of measurement for the potential is volt. This terminal will be used for Option installation. Refer to each Option manual of instruction for use.

## 12.3 Recommended Power Distribution System

In all cases, qualified personnel must verify that the transformer and feeder (at the point of take-off) and the run to the CT system meet all the requirements stated in this document.

### 12.3.1 Using a Dedicated Distribution Transformer (Recommended)

The recommended power distribution system for a CT system is a dedicated feeder from the facility main isolation transformer. The minimum recommended transformer size for a dedicated distribution transformer provided for the system is 125kVA (100kVA, standard) or 93.75kVA/62.5kVA (75kVA/50kVA, option), rated 2.4% regulation at unity power factor. [12.3.3 System Power Requirements on page 132](#) shows the minimum recommended feeder size and overcurrent protection device based on line voltage for this configuration.

## 12.3.2 Using an Existing Distribution Transformer

If it proves necessary to power the system from an existing distribution transformer and secondary feeder, such as the equipment distribution panel of an X-ray department, avoid installation with other X-ray equipment that uses rapid film changers. These changers use a large number of high-powered, closely-spaced exposures, which may coincide with the CT scan and produce image artifacts.

## 12.3.3 System Power Requirements

Be sure that the site can meet all of the minimum power requirements listed below before installing the system:

### 12.3.3.1 System Power Requirements for 100kVA

- Maximum power demand = 100kVA @ 0.85 PF: at a Selected Technique of 140 kV, 515 mA.
- Average effective (RMS) power demand at maximum duty cycle = 20 kVA.
- Average power demand at maximum duty cycle = 10 kVA
- Maximum allowable total source regulation is 6%.
- Minimum recommended transformer size: 125 kVA, with 2.4% rated regulation at unity power factor. Resultant maximum allowable feeder regulation is 3.6%.

**Table 12-1 Nominal Line Voltage Ranges**

<b>Nominal line voltage MUST fall within ONE of these ranges.</b>									
Nominal Line Voltage [V]	200	220	240	380	400	420	440	460	480
Peak Power [kVA]	100	100	100	100	100	100	100	100	100
Hi-Line Limit, +10% [V]	220	242	264	418	440	462	484	506	528
Lo-Line Limit, -10% [V]	180	198	216	342	360	378	396	414	432
Continuous Line Current [A]	58	52	48	30	29	27	26	25	24
Momentary Line Current [A]	289	262	241	152	144	137	131	126	120
Maximum Line Current [A]	321	292	267	169	160	153	146	139	134
Minimum Recommended Circuit Breaker [A]	150	150	150	125	125	100	100	90	90

**Table 12-2 Minimum Feeder Wire Size**

Feeder Length (MDA to A1/ MDP) Meters (Feet)	Minimum Feeder Wire Size, AWG -kcmil or MCM (sq. mm)/VAC (Supplied by Customer)								
	200VAC	220VAC	240VAC	380VAC	400VAC	420VAC	440VAC	460VAC	480VAC
15 m (50 ft)	1/0 (50)	1/0 (50)	1/0 (50)	2 (35)	2 (35)	4 (25)	4 (25)	4 (25)	4 (25)
30 m (100 ft)	2/0 (70)	1/0 (50)	1/0 (50)	2 (35)	2 (35)	4 (25)	4 (25)	4 (25)	4 (25)
46 m (150 ft)	4/0 (120)	3/0 (95)	3/0 (95)	2 (35)	2 (35)	4 (25)	4 (25)	4 (25)	4 (25)
61 m (200 ft)	250 (120)	4/0 (120)	4/0 (120)	2 (35)	2 (35)	4 (25)	4 (25)	4 (25)	4 (25)
76 m (250 ft)	300 (150)	250 (120)	250 (120)	1 (35)	1 (35)	2 (35)	2 (35)	2 (35)	4 (25)
91 m (300 ft)	350 (185)	300 (150)	250 (120)	1/0 (50)	1/0 (50)	1 (35)	1 (35)	2 (35)	2 (35)
107 m (350 ft)	400 (185)	350 (185)	300 (150)	2/0 (70)	1/0 (50)	1/0 (50)	1 (35)	1 (35)	1 (35)
122 m (400 ft)	400 (185)	350 (185)	350 (185)	2/0 (70)	2/0 (70)	1/0 (50)	1/0 (50)	1/0 (50)	1 (35)

**NOTE**

According to length and voltage, select the appropriate wire size. The length should consider the actual total length of feeder and sub-feeder.

**Table 12-3 Minimum Sub-Feeder Wire Size**

Sub-Feeder Length (A1/MDP to PDU) Meters (Feet)	Minimum Sub-Feeder Wire Size, AWG or MCM (sq. mm)/VAC (Supplied by Customer)								
	200VAC	220VAC	240VAC	380VAC	400VAC	420VAC	440VAC	460VAC	480VAC
9.75 m (32 ft)	1/0 (50)	1/0 (50)	1/0 (50)	2 (35)	2 (35)	4 (25)	4 (25)	4 (25)	4 (25)

**NOTE**

In all cases the recommended ground wire is a 1/0 (50 mm<sup>2</sup>) ground wire.

**NOTE**

If the wire size does not match the above lists, please select the nearest wire size as per to local standards.

The information in [Table 12-1 Nominal Line Voltage Ranges on page 132](#), [Table 12-2 Minimum Feeder Wire Size on page 133](#), and [Table 12-3 Minimum Sub-Feeder Wire Size on page 133](#) (above) assumes the use of copper wire, rated 75 C and run in steel conduit. All ampacity is determined in accordance with the National Electrical Code (NFPA 70), Table 310-16 (2002). The ampacity of the circuit protection device listed above determines the minimum feeder size, except where total source regulation limits require a larger size.

**NOTICE**

Power feeders running under the scan room floor, as well as power vault substations under the floor, above the scan suite, or in adjacent rooms, may cause excessive EMI fields. The responsibility for meeting all site EMI requirements rests with the customer.

### 12.3.3.2 System Power Requirements for 75kVA

- Maximum power demand = 75kVA @ 0.85 PF: at a Selected Technique of 120 kV, 460 mA.
- Average effective (RMS) power demand at maximum duty cycle = 20 kVA.
- Average power demand at maximum duty cycle = 10 kVA
- Maximum allowable total source regulation is 6%.
- Minimum recommended transformer size: 93.75 kVA, with 2.4% rated regulation at unity power factor. Resultant maximum allowable feeder regulation is 3.6%.

**Table 12-4 Nominal Line Voltage Ranges**

<b>Nominal line voltage MUST fall within ONE of these ranges.</b>									
Nominal Line Voltage [V]	200	220	240	380	400	420	440	460	480
Peak Power [kVA]	75	75	75	75	75	75	75	75	75
Hi-Line Limit, +10% [V]	220	242	264	418	440	462	484	506	528
Lo-Line Limit, -10% [V]	180	198	216	342	360	378	396	414	432
Continuous Line Current [A]	58	52	48	30	29	27	26	25	24
Momentary Line Current [A]	217	197	180	114	108	103	98	94	90
Maximum Line Current [A]	241	219	200	127	120	115	109	105	100
Minimum Recommended Circuit Breaker [A]	120	110	110	70	60	60	60	60	50

**Table 12-5 Minimum Feeder Wire Size**

Feeder Length (MDA to A1/ MDP) Meters (Feet)	Minimum Feeder Wire Size, AWG-kcmil or MCM (sq. mm)/VAC (Supplied by Customer)								
	200VAC	220VAC	240VAC	380VAC	400VAC	420VAC	440VAC	460VAC	480VAC
15 m (50 ft)	1 (35)	2 (35)	4 (25)	4 (25)	4 (25)	4 (25)	4 (25)	4 (25)	4 (25)
30 m (100 ft)	1/0 (50)	1/0 (50)	1 (35)	4 (25)	4 (25)	4 (25)	4 (25)	4 (25)	4 (25)
46 m (150 ft)	3/0 (95)	2/0 (70)	2/0 (70)	4 (25)	4 (25)	4 (25)	4 (25)	4 (25)	4 (25)
61 m (200 ft)	4/0 (120)	4/0 (120)	3/0 (95)	2 (35)	4 (25)	4 (25)	4 (25)	4 (25)	4 (25)
76 m (250 ft)	250 (120)	250 (120)	4/0 (120)	2 (35)	2 (35)	2 (35)	4 (25)	4 (25)	4 (25)
91 m (300 ft)	300 (150)	250 (120)	250 (120)	1 (35)	1 (35)	2 (35)	2 (35)	2 (35)	4 (25)
107 m (350 ft)	350 (185)	300 (150)	250 (120)	1/0 (50)	1/0 (50)	1 (35)	1 (35)	2 (35)	2 (35)
122 m (400 ft)	350 (185)	350 (185)	300 (150)	2/0 (70)	1/0 (50)	1/0 (50)	1 (35)	1 (35)	1 (35)

**Table 12-5 Minimum Feeder Wire Size (Table continued)**

Feeder Length (MDA to A1/ MDP) Meters (Feet)	Minimum Feeder Wire Size, AWG-kcmil or MCM (sq. mm)/VAC (Supplied by Customer)								
	200VAC	220VAC	240VAC	380VAC	400VAC	420VAC	440VAC	460VAC	480VAC
 <b>NOTE</b> According to length and voltage, select the appropriate wire size. The length should consider the actual total length of feeder and sub-feeder.									

**Table 12-6 Minimum Sub-Feeder Wire Size**

Sub-Feeder Length (A1/MDP to PDU) Meters (Feet)	Minimum Sub-Feeder Wire Size, AWG or MCM (sq. mm)/VAC (Supplied by Customer)								
	200VAC	220VAC	240VAC	380VAC	400VAC	420VAC	440VAC	460VAC	480VAC
9.75 m (32 ft)	1 (35)	2 (35)	4 (25)	4 (25)	4 (25)	4 (25)	4 (25)	4 (25)	4 (25)

**NOTE**

In all cases the recommended ground wire is a 1/0 (50 mm<sup>2</sup>) ground wire.



**NOTE**

If the wire size does not match the above lists, please select the nearest wire size as per to local standards.

The information in [Table 12-4 Nominal Line Voltage Ranges on page 134](#), [Table 12-5 Minimum Feeder Wire Size on page 134](#), and [Table 12-6 Minimum Sub-Feeder Wire Size on page 135](#) (above) assumes the use of copper wire, rated 75 C and run in steel conduit. All ampacity is determined in accordance with the National Electrical Code (NFPA 70), Table 310-16 (2002). The ampacity of the circuit protection device listed above determines the minimum feeder size, except where total source regulation limits require a larger size.

**NOTICE**

Power feeders running under the scan room floor, as well as power vault substations under the floor, above the scan suite, or in adjacent rooms, may cause excessive EMI fields. The responsibility for meeting all site EMI requirements rests with the customer.

### 12.3.3.3 System Power Requirements for 50kVA

- Maximum power demand = 50kVA @ 0.85 PF: at a Selected Technique of 120 kV, 280 mA.
- Average effective (RMS) power demand at maximum duty cycle = 20 kVA.
- Average power demand at maximum duty cycle = 10 kVA
- Maximum allowable total source regulation is 6%.
- Minimum recommended transformer size: 62.5 kVA, with 2.4% rated regulation at unity power factor. Resultant maximum allowable feeder regulation is 3.6%.

**Table 12-7 Nominal Line Voltage Ranges**

<b>Nominal line voltage MUST fall within ONE of these ranges.</b>									
Nominal Line Voltage [V]	200	220	240	380	400	420	440	460	480
Peak Power [kVA]	50	50	50	50	50	50	50	50	50
Hi-Line Limit, +10% [V]	220	242	264	418	440	462	484	506	528
Lo-Line Limit, -10% [V]	180	198	216	342	360	378	396	414	432
Continuous Line Current [A]	58	52	48	30	29	27	26	25	24
Momentary Line Current [A]	144	131	120	76	72	69	66	63	60
Maximum Line Current [A]	160	146	134	84	80	76	73	70	67
Minimum Recommended Circuit Breaker [A]	80	80	70	50	50	50	50	50	50

**Table 12-8 Minimum Feeder Wire Size**

Feeder Length (MDA to A1/ MDP) Meters (Feet)	Minimum Feeder Wire Size, AWG-kcmil or MCM (sq. mm)/VAC (Supplied by Customer)								
	200VAC	220VAC	240VAC	380VAC	400VAC	420VAC	440VAC	460VAC	480VAC
15 m (50 ft)	4 (25)	4 (25)	4 (25)	4 (25)	4 (25)	4 (25)	4 (25)	4 (25)	4 (25)
30 m (100 ft)	2 (35)	4 (25)	4 (25)	4 (25)	4 (25)	4 (25)	4 (25)	4 (25)	4 (25)
46 m (150 ft)	1/0 (50)	1 (35)	1 (35)	4 (25)	4 (25)	4 (25)	4 (25)	4 (25)	4 (25)
61 m (200 ft)	3/0 (95)	2/0 (70)	1/0 (50)	4 (25)	4 (25)	4 (25)	4 (25)	4 (25)	4 (25)
76 m (250 ft)	3/0 (95)	3/0 (95)	2/0 (70)	4 (25)	4 (25)	4 (25)	4 (25)	4 (25)	4 (25)
91 m (300 ft)	4/0 (120)	3/0 (95)	3/0 (95)	4 (25)	4 (25)	4 (25)	4 (25)	4 (25)	4 (25)
107 m (350 ft)	250 (120)	4/0 (120)	3/0 (95)	2 (35)	4 (25)	4 (25)	4 (25)	4 (25)	4 (25)
122 m (400 ft)	300 (150)	250 (120)	4/0 (120)	1 (35)	2 (35)	2 (35)	4 (25)	4 (25)	4 (25)

 **NOTE** According to length and voltage, select the appropriate wire size. The length should consider the actual total length of feeder and sub-feeder.

**Table 12-9 Minimum Sub-Feeder Wire Size**

Sub-Feeder Length (A1/MDP to PDU) Meters (Feet)	Minimum Sub-Feeder Wire Size, AWG or MCM (sq. mm)/VAC (Supplied by Customer)								
	200VAC	220VAC	240VAC	380VAC	400VAC	420VAC	440VAC	460VAC	480VAC
9.75 m (32 ft)	4 (25)	4 (25)	4 (25)	4 (25)	4 (25)	4 (25)	4 (25)	4 (25)	4 (25)

**NOTE**

In all cases the recommended ground wire is a 1/0 (50 mm<sup>2</sup>) ground wire.

**NOTE**

If the wire size does not match the above lists, please select the nearest wire size as per to local standards.

The information in [Table 12-7 Nominal Line Voltage Ranges on page 136](#), [Table 12-8 Minimum Feeder Wire Size on page 136](#), and [Table 12-9 Minimum Sub-Feeder Wire Size on page 136](#) (above) assumes the use of copper wire, rated 75 C and run in steel conduit. All ampacity is determined in accordance with the National Electrical Code (NFPA 70), Table 310-16 (2002). The ampacity of the circuit protection device listed above determines the minimum feeder size, except where total source regulation limits require a larger size.

**NOTICE**

Power feeders running under the scan room floor, as well as power vault substations under the floor, above the scan suite, or in adjacent rooms, may cause excessive EMI fields. The responsibility for meeting all site EMI requirements rests with the customer.

Page intentionally left blank

## 13 Interconnection Data

### 13.1 Introduction

The customer and the customer's electrical contractor should refer to the information in this section when establishing network and power interconnections for the system. Please note the following:

- [Figure 13-2 Interconnection Runs on page 150](#) shows interconnection runs for a 50/60 Hz system.
- [Table 13-1 Component Designators on page 139](#) shows component designators for supplied equipment and options and wall power outlets.
- [Table 13-9 Runs 1, 2, 3, 4 and 5 Connections on page 148](#) lists customer-installed wiring and supplied cables. The actual length of each run is less than the length of supplied cables to allow for routing inside the equipment. Cable diameters and sizes of connectors are provided to aid in sizing conduit and access plates.
- [13.3.1 GE Supplied System Cable \(Open Console\) on page 140](#) and [13.3.2 GE Supplied System Cable \(StandAlone Console\) on page 142](#) list details for connection to the system and GE approved accessories using standard (short) length and non-standard (long) length cables, respectively. Details appear for the following types of runs, when appropriate:
  - Flush-floor duct
  - Computer floor
  - Through-wall bushing
  - Junction box
  - Surface floor duct
  - Through-floor duct
  - Wall duct
  - Conduit
- To minimize the need for additional junction boxes, use either a cable raceway system or a raised computer floor. Systems use prefabricated cables with large plugs. Therefore, try to avoid conduit or pipe for cable runs.

### 13.2 Component Designators

**Table 13-1 Component Designators**

DESIGNATOR	APPLIES TO	SOURCE
A1	Primary power disconnect	<b>Contractor supplied</b>
MDP	Main distribution panel	<b>Contractor supplied</b>
CT1	Patient table	System
CT2	Gantry	System
OC1	console/computer	System
PDU	Power Distribution Unit	System
SEO	System emergency off	<b>Contractor supplied</b>
SM	Slave monitor	Option
WL	"X-ray on" warning light	<b>Contractor supplied</b>
DS	Door Interlock Switch	<b>Contractor supplied</b>

**Table 13-1 Component Designators** (Table continued)

DESIGNATOR	APPLIES TO	SOURCE
BBNC	Broad-band network connection	Contractor supplied

## 13.3 Interconnect Runs, Wiring and Cables

### 13.3.1 GE Supplied System Cable (Open Console)

#### 13.3.1.1 GE Supplied Standard Length 5824111 (Reference IEC 60601-1-2 2007; 2014; 2020)

**Table 13-2 GE Supplied Cables (Standard Run, Short) - UL Information**

Run #	Length, Actual (Usable)		Part #	Description	UL Cable Information								Pull Size mm (Inches)
	ft	m			UL Style	Flam. Rating	Voltage Rating	Voltage Actual	Temp. Rating (C)	Dia. mm (inch)	# of Cond	Size AWG	
50	28 (20)	8.5 (6)	5824788-2	HVDC, PDU to Gantry	2587	FT4	600	350VDC	90	19 (0.75)	3	(2) 4 (1) 8	22 (0.87) Dia.
51	28 (20)	8.5 (6)	5824792-2	HVAC, PDU to Gantry	2587	FT4	600	440Y/254	90	15 (0.59)	4	14	11 (0.44) Dia.
52	28 (20)	8.5 (6)	5824791-2	LVAC, PDU to Gantry	2587	FT4	600	208Y/120	90	14 (0.55)	5	8	56 (2.2) Dia.
53	65 (59)	20 (18)	5824978-2	LVAC, PDU to Console	2587	FT4	600	120VAC	90	12 (0.47)	3	10	56 (2.2) Dia.
54			n/a	LVAC, Gantry to Table	1015		600	120VAC			3	14	
55	28 (20)	8.5 (6)	5824785-2	Ground, PDU to raceway	1284	VW-1 (FT-1)	600	0	105	16 (0.63)	1	1/0	16 (0.63) Dia.
56	69 (56)	21 (17)	5824785-4	Ground, Raceway to console	1283	VW-1 (FT-1)	600	0	105	12 (0.47)	1	2	12 (0.47) Dia.
100	33 (20)	10 (6)	5824794-2	Signal, Gantry TGPG to PDU		FT-4	300	<30VDC	80	11 (0.433)	25	22	17 x 58 (0.68 x 2.30)

**Table 13-2 GE Supplied Cables (Standard Run, Short) - UL Information** (Table continued)

Run #	Length, Actual (Usable)		Part #	Description	UL Cable Information								Pull Size mm (Inches)
	ft	m			UL Style	Flam. Rating	Voltage Rating	Voltage Actual	Temp. Rating (C)	Dia. mm (inch)	# of Cond	Size AWG	
101	72 (60)	22 (18)	5824787-2	Signal, Gantry TGPG to OC	2464	VM-1	300	<30VD C	80	12.5 (0.49)	25	22	17 x 58 (0.68 x 2.30)
102	72 (60)	22 (18)	5824786-2	Signal (LAN), Gantry to OC	CAT5 E CM	CM	300	<30VD C	75	6 (0.236)	8	24	15 (0.59) Dia.
103	65 (60)	20 (18)	5478856-2	Fiber Optic, Gantry to OC			N/A	N/A			1	N/A	10 (0.39) Dia
104			n/a	Signal, Gantry to Table		FT-4	300		80	6 (0.236)	25	22	

### 13.3.1.2 GE Supplied Long Run Length 5824111-2 (Reference IEC 60601-1-2 2007; 2014; 2020)

**Table 13-3 GE Supplied Cables (Option Run, Long) - UL Information**

Run #	Length, Actual (Usable)		Part #	Description	UL Cable Information								Pull Size mm (Inches)
	ft	m			UL Style	Flam. Rating	Voltage Rating	Voltage Actual	Temp. Rating (C)	Dia. mm (inch)	# of Cond	Size AWG	
50	62 (56)	19 (17)	5824788	HVDC, PDU to Gantry	2587	FT4	600	350VD C	90	19 (0.75)	3	(2) 4 (1) 8	22 (0.87) Dia.
51	62 (56)	19 (17)	5824792	HVAC, PDU to Gantry	2587	FT4	600	440Y/2 54	90	15 (0.59)	4	14	11 (0.44) Dia.
52	62 (53)	19 (16)	5824791	LVAC, PDU to Gantry	2587	FT4	600	208Y/1 20	90	14 (0.55)	5	8	56 (2.2) Dia.
53	82 (76)	25 (13)	5824978	LVAC, PDU to Console	2587	FT4	600	120VAC	90	12 (0.47)	3	10	56 (2.2) Dia.
54			n/a	LVAC, Gantry to Table	1015		600	120VAC			3	14	

**Table 13-3 GE Supplied Cables (Option Run, Long) - UL Information** (Table continued)

Run #	Length, Actual (Usable)		Part #	Description	UL Cable Information								Pull Size mm (Inches)
	ft	m			UL Style	Flam. Rating	Voltage Rating	Voltage Actual	Temp. Rating (C)	Dia. mm (inch)	# of Cond	Size AWG	
55	62 (53)	19 (16)	5824785	Ground, PDU to raceway	1284	VW-1 (FT-1)	600	0	105	16 (0.63)	1	1/0	16 (0.63) Dia.
56	86 (72)	26 (22)	5824785-3	Ground, Raceway to console	1283	VW-1 (FT-1)	600	0	105	12 (0.47)	1	2	12 (0.47) Dia.
100	69 (56)	21 (17)	5824794	Signal, Gantry TGPG to PDU		FT-4	300	<30VDC	80	11 (0.44)	25	22	17 x 58 (0.68 x 2.30)
101	85 (72)	26 (22)	5824787	Signal, Gantry TGPG to OC	2464	VM-1	300	<30VDC	80	12.5 (0.49)	25	22	17 x 58 (0.68 x 2.30)
102	85 (72)	26 (22)	5824786	Signal (LAN), Gantry to OC	CAT5 E CM	CM	300	<30VDC	75	6 (0.236)	8	24	15 (0.59) Dia.
103	85 (76)	26 (23)	5478856	Fiber Optic, Gantry to OC			N/A	N/A			1	N/A	10 (0.39) Dia
104			n/a	Signal, Gantry to Table		FT-4	300		80	6 (0.234)	25	22	

### 13.3.2 GE Supplied System Cable (StandAlone Console)

## 13.3.2.1 GE Supplied Standard Length 5824782 (Reference IEC 60601-1-2 2007; 2014; 2020)

Table 13-4 GE Supplied Cables (Standard Run, Short) - UL Information

Run #	Length, Actual (Usable)		Part #	Description	UL Cable Information								Pull Size mm (Inches)
	ft	m			UL Style	Flam. Rating	Voltage Rating	Voltage Actual	Temp. Rating (C)	Dia. mm (inch)	# of Cond	Size AWG	
50	28 (20)	8.5 (6)	5824788-2	HVDC, PDU to Gantry	2587	FT4	600	350VDC	90	19 (0.75)	3	(2) 4 (1) 8	22 (0.87) Dia.
51	28 (20)	8.5 (6)	5824792-2	HVAC, PDU to Gantry	2587	FT4	600	440V/254	90	15 (0.59)	4	14	11 (0.44) Dia.
52	28 (20)	8.5 (6)	5824791-2	LVAC, PDU to Gantry	2587	FT4	600	208Y/120	90	14 (0.55)	5	8	56 (2.2) Dia.
53	69 (62)	21 (19)	5808965-2	LVAC, PDU to Console	2587	FT4	600	120VAC	90	12 (0.47)	3	10	56 (2.2) Dia.
54			n/a	LVAC, Gantry to Table	1015		600	120VAC			3	14	
55	28 (20)	8.5 (6)	5824785-2	Ground, PDU to raceway	1284	VW-1 (FT-1)	600	0	105	16 (0.63)	1	1/0	16 (0.63) Dia.
56	69 (56)	21 (17)	5824785-4	Ground, Raceway to console	1283	VW-1 (FT-1)	600	0	105	12 (0.47)	1	2	12 (0.47) Dia.
100	33 (20)	10 (6)	5824794-2	Signal, Gantry TGPG to PDU		FT-4	300	<30VDC	80	11 (0.433)	25	22	17 x 58 (0.68 x 2.30)
101	72 (60)	22 (18)	5824787-2	Signal, Gantry TGPG to OC	2464	VM-1	300	<30VDC	80	12.5 (0.492)	25	22	17 x 58 (0.68 x 2.30)
102	72 (60)	22 (18)	5824786-2	Signal (LAN), Gantry to OC	CAT5 E CM	CM	300	<30VDC	75	6 (0.236)	8	24	15 (0.59) Dia.
103	65 (60)	20 (18)	5478856-2	Fiber Optic, Gantry to OC			N/A	N/A			1	N/A	10 (0.39) Dia

**Table 13-4 GE Supplied Cables (Standard Run, Short) - UL Information** (Table continued)

Run #	Length, Actual (Usable)		Part #	Description	UL Cable Information								Pull Size mm (Inches)
	ft	m			UL Style	Flam. Rating	Voltage Rating	Voltage Actual	Temp. Rating (C)	Dia. mm (inch)	# of Cond	Size AWG	
104			n/a	Signal, Gantry to Table		FT-4	300		80	6 (0.236)	25	22	
	75 (69)	23 (21)	5824760-2	Signal, PS 12V to GSCB	2464	VW-1	300	12V	80	5.8 (0.228)	2	18	

### 13.3.2.2 GE Supplied Long Run Length 5824782-2 (Reference IEC 60601-1-2 2007; 2014; 2020)

**Table 13-5 GE Supplied Cables (Option Run, Long) - UL Information**

Run #	Length, Actual (Usable)		Part #	Description	UL Cable Information								Pull Size mm (Inches)
	ft	m			UL Style	Flam. Rating	Voltage Rating	Voltage Actual	Temp. Rating (C)	Dia. mm (inch)	# of Cond	Size AWG	
50	62 (56)	19 (17)	5824788	HVDC, PDU to Gantry	2587	FT4	600	350VDC	90	19 (0.75)	3	(2) 4 (1) 8	22 (0.87) Dia.
51	62 (56)	19 (17)	5824792	HVAC, PDU to Gantry	2587	FT4	600	440Y/254	90	15 (0.59)	4	14	11 (0.44) Dia.
52	62 (53)	19 (16)	5824791	LVAC, PDU to Gantry	2587	FT4	600	208Y/120	90	14 (0.55)	5	8	56 (2.2) Dia.
53	82 (76)	25 (23)	5808965	LVAC, PDU to Console	2587	FT4	600	120VAC	90	12 (0.47)	3	10	56 (2.2) Dia.
54			n/a	LVAC, Gantry to Table	1015		600	120VAC			3	14	
55	62 (53)	19 (16)	5824785	Ground, PDU to raceway	1284	VW-1 (FT-1)	600	0	105	16 (0.63)	1	1/0	16 (0.63) Dia.
56	86 (72)	26 (22)	5824785-3	Ground, Raceway to console	1283	VW-1 (FT-1)	600	0	105	12 (0.47)	1	2	12 (0.47) Dia.

**Table 13-5 GE Supplied Cables (Option Run, Long) - UL Information** (Table continued)

Run #	Length, Actual (Usable)		Part #	Description	UL Cable Information								Pull Size mm (Inches)
	ft	m			UL Style	Flam. Rating	Voltage Rating	Voltage Actual	Temp. Rating (C)	Dia. mm (inch)	# of Cond	Size AWG	
100	69 (56)	21 (17)	5824794	Signal, Gantry TGPG to PDU		FT-4	300	<30VDC	80	11 (0.433)	25	22	17 x 58 (0.68 x 2.30)
101	85 (72)	26 (22)	5824787	Signal, Gantry TGPG to OC	2464	VM-1	300	<30VDC	80	12.5 (0.492)	25	22	17 x 58 (0.68 x 2.30)
102	85 (72)	26 (22)	5824786	Signal (LAN), Gantry to OC	CAT5 E CM	CM	300	<30VDC	75	6 (0.236)	8	24	15 (0.59) Dia.
103	85 (76)	26 (23)	5478856	Fiber Optic, Gantry to OC			N/A	N/A			1	N/A	10 (0.39) Dia
104			n/a	Signal, Gantry to Table		FT-4	300		80	6 (0.236)	25	22	
	89 (82)	27 (25)	5824760	Signal, PS 12V to GSCB	2464	VW-1	300	12V	80	5.8 (0.228)	2	18	

### 13.3.3 GE Supplied Option Cables (Reference IEC 60601-1-2 2007; 2014; 2020)

**Table 13-6 GE Supplied Cables for Option - UL Information**

Run #	Length, Actual (Usable)		Part #	Description	UL Cable Information								Pull Size mm (Inches)
	ft	m			UL Style	Flam. Rating	Voltage Rating	Voltage Actual	Temp. Rating (C)	Dia. mm (inch)	# of Cond	Size AWG	
In-jector	100	30.5	5169456	Gantry to Injector	1007	VW-1	300	<30VDC	80	1.57 (0.062)	3	22	45 (1.78) Dia.
	8.2	2.5	5317258	Power Cable Injector to Console	62	VW-1	300	120VAC	60	9.4 (0.37)	3	14	36 (1.41) Dia

**Table 13-6 GE Supplied Cables for Option - UL Information** (Table continued)

Run #	Length, Actual (Usable)		Part #	Description	UL Cable Information								Pull Size mm (Inches)
	ft	m			UL Style	Flam. Rating	Voltage Rating	Voltage Actual	Temp. Rating (C)	Dia. mm (inch)	# of Cond	Size AWG	
Cardiac	18	5.5	5314085	Gantry to EKG Monitor	2919	UL1685 UL Loading	30	<30VDC	80	6.45 (0.254)	6	24	37 (1.45) Dia
Adv 4D Resp	100	30.5	5199717	Gantry to RPM Unit	2464	FT4	300	<30VDC	80	6.6 (0.26)	4	22	37 (1.45) Dia
Depth Camera (Express Mode)	98.4	30	5809034-3	Depth Camera to Console	-	UL1666 CMR or above	-	-	-	-	-	22	-
RCP Camera	2.3	0.7	5854842/5854842-2	RCP Cable Harness	-	UL	-	-	-	-	-	-	-
	82	25	5854840	RCP Interface Cable	-	UL	-	-	-	-	-	-	-
	98.4	30	5863794 5863794-2 5863794-3	LAN Cable for AVI-MOS Camera	-	CAT6	-	-	-	-	-	-	-

### 13.3.4 UPS Wiring Cables (Reference IEC 60601-1-2 2007; 2014; 2020)

Table 13-7 CT Partial UPS 10kVA Hardware Kit

Run #	Length, Actual (Usable)		Part #	Description	UL Cable Information								Pull Size mm (Inches)
	ft	m			UL Style	Flam. Rating	Voltage Rating	Voltage Actual	Temp. Rating (C)	Dia. mm (inch)	# of Cond	Size AWG	
060	15 (7)	4.6 (2)	5817584	Power Cable for 2PH UPS, NGPDU TS4 to UPS TB1	E3195 45	FT2	600	208VAC	-	8.37 (0.33)	-	8	-
061	15 (7)	4.6 (2)	5817583	Power Cable for 2PH UPS, NGPDU TS4 to UPS TB1	E3195 45	FT2	600	208VAC	-	8.37 (0.33)	-	8	-
110	46 (36)	14 (11)	5817581	UPS Control Cable, A1/MDP TB1 to UPS	2464	FT4	-	120VAC	-	8 (0.3)	-	18	-

### 13.3.5 A1/MDP-UPS

Figure 13-1 Typical Interconnect

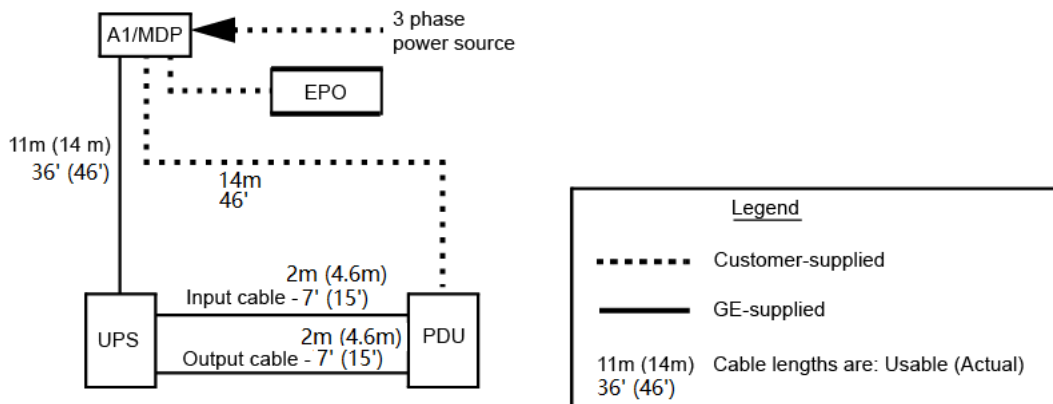

**NOTE** UPS Kit REQUIRES installation of one of the A1/MDP panels listed below.

**Table 13-8 A1/MDP-UPS**

PDU Type & Model No.	Maximum Nom. kVA Rating	Required Main Disconnect Panel Catalog No.			Partial UPS
		Global except EMEA		EMEA	
		440V~480V, 90A	380V~420V, 110A	380V~420V, 125A	
NGPDU-81 2326492-81	100kVA	<b>E4502BB</b> (incl. Auto Restart & Integrated UPS Control)	<b>E4502BC</b> (incl. Auto Restart & Integrated UPS Control)	<b>E45021BB</b> (incl. Auto Restart & Integrated UPS Control)	<b>E4502KZ (WSO)</b> <b>B77552DA (BHW/HINO)</b> (includes 5820687 Liebert GXT4 model 10kVA, 2ph UPS & hardware kit) requires one of the A1/MDP Panels shown at left



**NOTE**

Conduit is required between the:

- A1/MDP and UPS
- UPS and PDU
- PDU and A1/MDP

### 13.3.6 Contractor/Customer Supplied

**Table 13-9 Runs 1, 2, 3, 4 and 5 Connections**

Customer Installed Wiring		Description	Cables Supplied			Plug Pulling Dimensions		Wire and Cable Pigtails ft. (m)	
Qty	Size AWG (mm <sup>2</sup> )		Part No.	Length ft. (m)	Dia. in. (mm)	From	To	From	To
<b>RUN NO. 1 FROM PRIMARY POWER SOURCE TO FACILITY DISCONNECT (POWER SOURCE - A1/MDP)</b>									
<p><b>NOTE</b> The primary power ground to the A1/MDP disconnect must meet local codes, in all cases the recommended ground wire is a 1/0 (50 mm<sup>2</sup>) ground wire.</p> <p>Maximum Run Length *</p>									
3	*	Power						3 (1)	3 (1)
1	1/0 (50)	Ground						3 (1)	3 (1)
<b>RUN NO. 2 FROM FACILITY DISCONNECT TO POWER DISTRIBUTION UNIT (A1/MDP - PM)</b>									
3	*	Power						3 (1)	3 (1)
1	1/0 (50)	Ground						3 (1)	3 (1)
-	-	Neutral - Not Required						3 (1)	3 (1)
<b>RUN NO. 3 A1/MDP PANEL</b>									
* BEVCO PANEL - FROM FACILITY DISCONNECT TO SYSTEM EMERGENCY POWER OFF (A1/MDP - EPO)									

**Table 13-9 Runs 1, 2, 3, 4 and 5 Connections** (Table continued)

Customer Installed Wiring		Description	Cables Supplied			Plug Pulling Dimensions		Wire and Cable Pigtails ft. (m)	
Qty	Size AWG (mm <sup>2</sup> )		Part No.	Length ft. (m)	Dia. in. (mm)	From	To	From	To
2	14 (2.5)	Partial UPS EPO Circuit						6 (2)	6 (2)
2	14 (2.5)	Facility Disconnect EPO Circuit						6 (2)	6 (2)
1	14 (2.5)	Ground						6 (2)	6 (2)
<b>RUN NO. 4 POWER DISTRIBUTION UNIT TO WARNING LIGHT CONTROL (PDU - WL)</b>									
2	14 (2.5)	Warning Light 24 Volt Control TS6 1, 2, 3, 4, 5, 6, 7, 8							
<b>RUN NO. 5 POWER DISTRIBUTION UNIT TO SCAN ROOM DOOR INTERLOCK (PDU - DOOR SWITCH)</b>									
2	14 (2.5)	Scan Room Door Inter Lock TS6 9, 10							
*	Refer to System Power Requirements for AWG (mm <sup>2</sup> ) wire sizes.								
<b>RUN NO. n/a BBNC</b>									
1	Customer Determined	Hospital Broadband Network Connection (Wall Jack: Placed on the wall behind the console.)							

**Figure 13-2 Interconnection Runs**

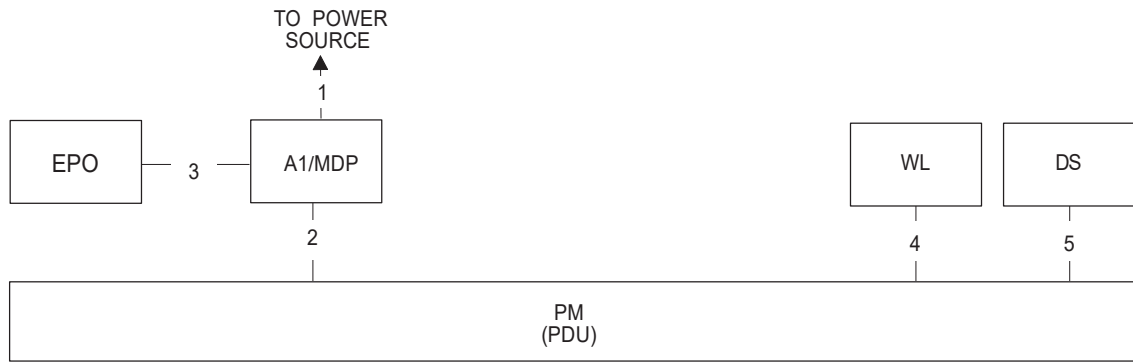

**NOTES**

- 1) Used for remote diagnostics - Option
- 2) Refer to the appropriate Pre--installation / Installation documents for the Laser Camera
- 3) Category 5 cable. Use one of the following patch cords.

CAT Num	GE Part Num	Length
K9000WB	2215028-10	20 m
K9000KP	2215028-5	10 m
K9000JR	2215028-4	5 m
K9000WA	2215028-9	3 m

- 4) In order to avoid any violation of each National Regulation (NEC in USA, CCC in China, etc.), use of the compliant cable/wire is recommended. For China market, China end-user shall purchase the power supply cable that has the CCC mark.

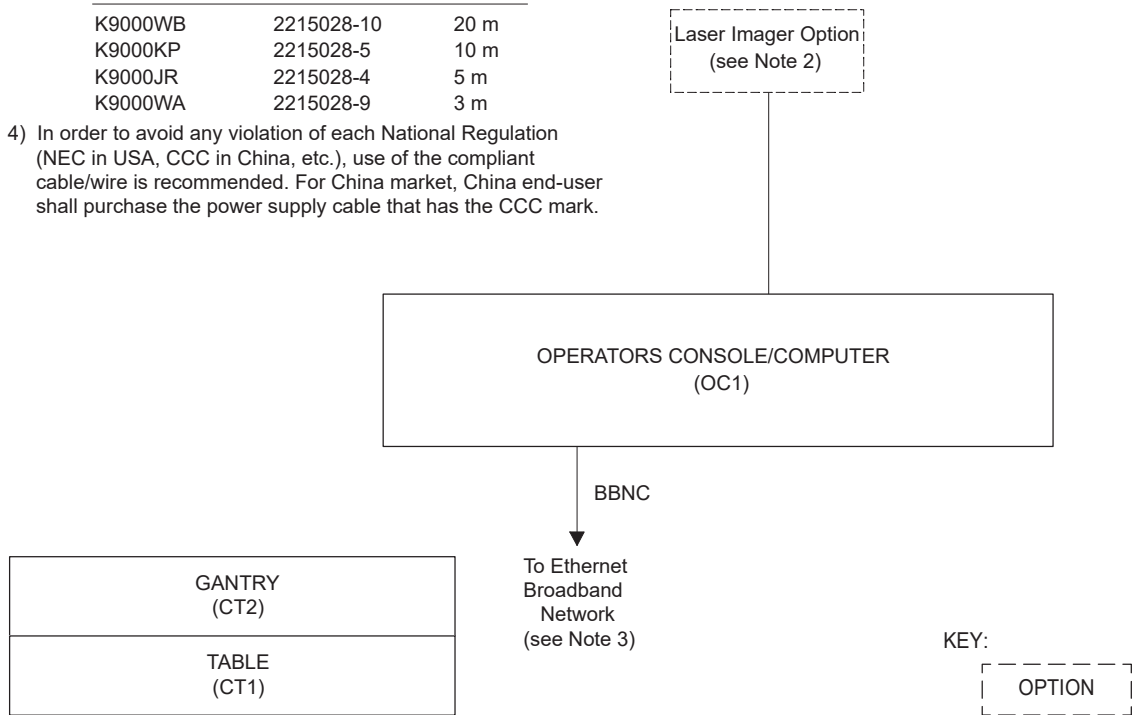

KEY:  
OPTION

# 13.4 Contractor Supplied Components

**Table 13-10 Contractor Supplied Components**

Reference	Associated Equipment	Material/Labor Supplied by Customer Contractor	USA Vendor / CAT No. GE Catalog
A1/MDP 380 - 480V, 50/60 Hz	Fusible Dis- connect and Magnetic Con- tactor	3 Pole, 380V - 480V, Combination breaker with magnetic con- tactor. Includes control transformer, optional UPS interface, On/Off controls and auto-restart feature.	Recommend* <sup>1</sup> <ul style="list-style-type: none"> <li>E4502BB (90A)</li> <li>E4502BC (110A)</li> <li>E45021BB (125A)</li> </ul>
BBNC (re- quired)	Broad-Band Network Con- nection	Broad-Band network connection wall jack, located within 1m (39inches) of Operator Console location, for internal hospital networking and InSite Broad-Band connectivity.  Cabling to conform to facility's IT standards.	
	System Com- ponents	Reference the system installation drawings supplied by Instal- lation Support Services within your geographic area.	

\*<sup>1</sup>: Refer to 13.3.5 A1/MDP-UPS on page 147.

# 13.5 Scan Room Warning Light and Door Interlock

**Figure 13-3 TS6 X-Ray Warning Light Connections**

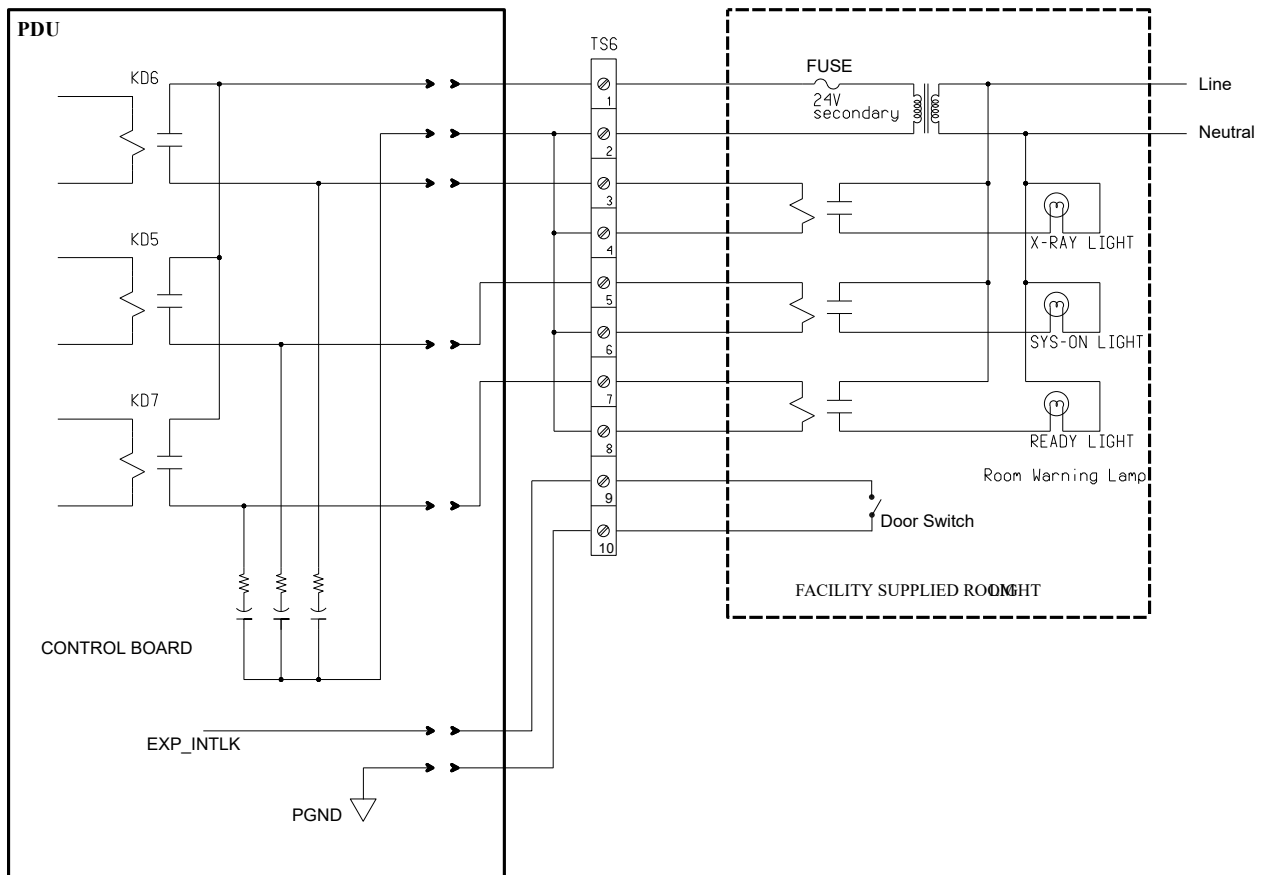

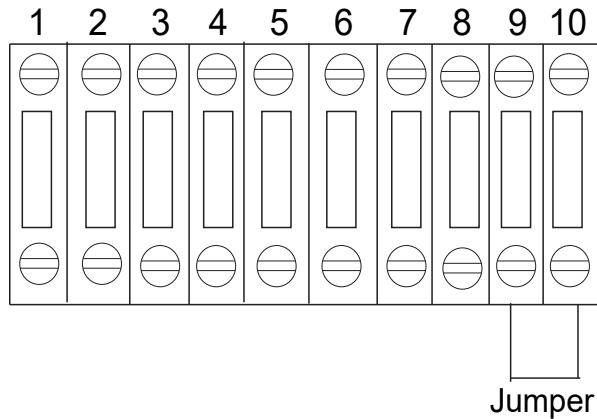
**Figure 13-4 TS6 Room Door Interlock Connections - Without a Door Interlock**

If not using a door switch, add a jumper.

If jumper is not in place, exposures will not be made. Check this jumper if you get scan interlock errors.

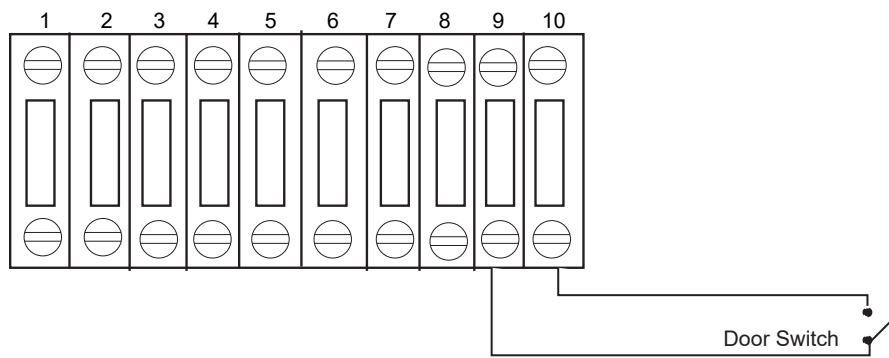
**Figure 13-5 TS6 Room Door Interlock Connections - With a Door Interlock**

## 13.6 Typical Customer Supplied Wiring

### Primary Power Disconnect

Requires LOTO compatible disconnect to install this system.

If a UPS is required, a GE Disconnect is strongly recommended for safe operation. The GE disconnect and UPS are designed to work together.

Details refer to DOC2058932 on SIMS Content Viewer. This is a restricted file, contact your PMI for specific questions or concerns.

## 14 Delivery and Storage Requirements

This chapter provides information necessary for planning a safe and successful delivery of the system from GE HealthCare to the receiving area of the installation site, and from the receiving area of that facility to the scan suite.

### 14.1 Delivery Types and System Lifting and Rigging Restriction



#### **DANGER**

PERSONAL INJURY OR DEATH, EQUIPMENT DAMAGE. TIP HAZARD.

GANTRY IS VERY HEAVY AND MAY TIP OVER IF TILTED PAST 10 DEGREES.

WHEN TRANSPORTING A SYSTEM TO THE FINAL DESTINATION, DO NOT EXCEED TILT ANGLE EQUAL TO, OR GREATER THAN 10 DEGREES IN EITHER DIRECTION OF AXIS.



#### **NOTE**

The system shall never be lifted by the dollies.

Your Project Manager of Installation will determine the most appropriate means of transporting the system to your facility. However, the type of receiving area at the facility where the installation will occur determines, to a large extent, the method used to transport the system to that facility. When planning for delivery, facilities fall into two general categories: those with a loading dock, and those without a loading dock.

#### 14.1.1 Loading Dock Deliveries

Facilities with a loading dock in their receiving area can generally accommodate delivery of the system by van. This is the preferred method of transporting the system to the installation site, as dock-to-dock shipment by van minimizes the possibility of dropping the gantry. Also, packing the CT system for van shipment involves minimum tear-down of components. This system is shipped Lean packed on pallets and dollies with approximately 10 units.

#### 14.1.2 Ground (Non-Loading Dock) Deliveries

Facilities without a loading dock usually require ground delivery by either liftgate or appropriately sized forklift. Such deliveries require unloading the system components from the truck and then rolling them across smooth sidewalks or other paved surfaces into the facility.

##### 14.1.2.1 Liftgate Truck

Delivery of the system by liftgate truck requires an appropriate capacity truck with a liftgate capable of lifting 3 tons. If using a rollback truck, the Project Manager of Installation should be on-site at the time of delivery to supervise this operation in person.

### 14.1.2.2 Tiltbed Truck - NOT Approved

Delivery of the system by tilt-bed truck is no longer an approved delivery method due to EHS safety risks of tipping the system over. If a loading dock is not available, then a Fork-lift truck shall instead be used.

### 14.1.2.3 Forklift Truck



#### NOTE

The tines on the fork truck need to be a minimum of 8' long in order to pick the gantry on the lifting skid past the center point of gravity.

A forklift can be used to unload the gantry, provided that the lifting option is ordered and delivered. The system will arrive with a lifting skid attached to the gantry and table. This option cannot be added later as an on-site addition.

### 14.1.2.4 Rigging

The CT gantry assemblies shall not be lifted by their dollies. The CT gantry assemblies shall not be transported across any surface by any means other than the dollies provided by GE HealthCare. The CT gantry assemblies have no lifting points on them and are not designed to be lifted by any special rigging attached to the gantry assemblies themselves.



#### **DANGER**

POSSIBLE SEVERE PERSONAL INJURY OR DEATH.

THE DOLLIES ARE NOT DESIGNED TO BE USED AS AN ATTACHMENT POINT FOR ANY METHOD OF LIFTING THE SUBSYSTEMS.

ATTACHING LIFTING STRAPS, CABLES OR MECHANISMS TO THE DOLLY HANDLES OR ANY OTHER PART OF THE DOLLY IS STRICTLY PROHIBITED.

#### **NOTICE**

If it is determined that the subsystems must be lifted by crane or other lifting method the PM or person responsible for local siting of the system shall NOT proceed with the installation without consulting directly with GE HealthCare Engineering.

Lifting the subsystems by crane or other lifting method should always be avoided. All alternate methods of delivery should be evaluated including the removal of any obstructions, doorways, walls, and windows.

If lifting is still required:

1. The entire gantry assembly and both gantry transport side dollies must be placed on a lifting platform. GE HealthCare does not provide a lifting platform.



#### NOTE

If the platform has limited space, the gantry transport side dollies may be removed during the lift. Once the lift is completed, the gantry transport side dollies must be installed back on the gantry assembly.

2. The entire patient table must be on its dollies and lifted while sitting on a lifting platform.

The patient table on its dolly shall be lowered to its transport position so the table base is in contact with the platform.

3. The platform must be designed so no lifting straps or cables come in contact with any part of the gantry or table subsystems or its side dollies.
4. The lifting platform shall bear the entire load. No part of the subsystem shall bear any load during the lift.

**NOTE**

If delivery requires vertical or horizontal lifting, the PM needs to add the necessary identifier to the order.

## 14.2 Delivery to the Scan Suite

Once at the installation site, conveyance of the system into the scan suite may involve special considerations, such as vertical lifting, or transportation through stairwells, which involves additional planning by the Project Manager of Installation.

### 14.2.1 Packing Dimension

**Table 14-1 Packing Dimension**

SubSystem	Length mm (in.)	Width mm (in.)	Height mm (in.)	NW kg (lb)	GW kg (lb)
Gantry	2220 mm (87 in.)	1270 mm (50 in.)	2376 mm (93.5 in.)	1558 kg (3434 lb)	1750 kg (3858 lb)
GT Table	3200 mm (126 in.)	900 mm (35 in.)	1360 mm (53.5 in.)	446 kg (983 lb)	522 kg (1151 lb)
Lite Table	2460 mm (96.9 in.)	960 mm (37.8 in.)	1400 mm (55.1 in.)	400 kg (882 lb)	445 kg (981 lb)
PDU	900 mm (35 in.)	700 mm (27.6 in.)	1230 mm (48.4 in.)	369 kg (814 lb)	407 kg (897 lb)
OC	920 mm (36.2 in.)	590 mm (23.2 in.)	770 mm (30.3 in.)	65 kg (143 lb)	104 kg (229 lb)

### 14.2.2 Lifting

Both vertical and horizontal lifting require professional riggers.

If delivery requires horizontal lifting, the PMI should contact with CT engineering team with installation concession.

If delivery requires vertical lifting and deviates from the requirement outlined in the PIM then engineering must be contacted for approval.

#### 14.2.2.1 Stairway Deliveries

Stairways with angles at or less than 45 degrees can accommodate delivery of system components. If the site requires delivery through stairwells, the PMI adds the appropriate identifier to the order to ensure proper packaging of the system, and notifies CT engineering before attempting the procedure. The components ship attached to special lifting skids with lifting instruction for riggers.

## 14.2.3 Floor Protection

GE recommends floor protection along the delivery path from the dock/receiving area to scan room.

## 14.2.4 Un-loading and un-packing the System

Retain the packaging surrounding the following components:

- Console-Shipped on a shock resistant skid. Do not remove the skid.
- UPS-Shipped on a shock resistant skid. Do not remove the skid.

## 14.3 Dollies

- The system gantry equipped **Gantry Dollies (B76142DA)**, there may be two types of B76142DA in the field:
  - Heavy Gantry Dolly: refer *Installation Manual (5809945-1EN)* for details.
  - New Lightweight Gantry Dolly: refer *Gantry Dolly Installation Manual (Direction: 5953370-1EN)* for details.

**Figure 14-1 Gantry Dolly (B76142DA)**

Heavy Gantry Dolly



LightWeight Gantry Dolly



- If the customer already has **Gantry Dollies (B78502CA)**, just order **Gantry Dolly Bracket Kit (B76072DA)** to replace the dolly brackets, the detail replacement procedure refers to *Installation Manual (5809945-1EN)*.

**Figure 14-2 Gantry Dolly (B78502CA)**

### 14.3.1 Installations within the United States

Typically, domestic shipments (shipments within the United States) involve the use of dollies for moving the gantry, table, and console. After completing installation, return the dollies to GE using the shipping document found in Box #1.

### 14.3.2 Zero Clearance Dollies

Deliveries involving small elevators with a depth of at least 2692 mm (106 in.) require zero clearance dollies. Zero clearance dollies allow movement of the gantry in tight areas; avoid using them for normal dock or van deliveries. To order zero clearance dollies, go to: <http://www.umi-dollyshop.com>.

### 14.3.3 Tilting Table Dollies

Deliveries involving small elevators with a depth of at least 2438 mm (96 in.) require tilting table dollies. If storing the system prior to installation, do not order tilt dollies. If you are unable to obtain tilt dollies for delivery, substitute riggers in their place. A limited number of tilt dollies exist for U.S. deliveries. To order tilt dollies, go to: <http://www.umi-dollyshop.com>.

### 14.3.4 Installations Outside of the United States

Customers may purchase dollies (B76142DA) for shipments outside of the United States. After removing the system from the crates, DO NOT return dollies shipped outside of the US to GE Healthcare in Milwaukee, WI, USA. Instead, forward them to the local GE office or warehouse.

Zero Clearance and Tilting Table dollies can be purchased through UMI, To buy tilt dollies, go to: <http://www.umi-dollyshop.com>.

## 14.4 Gantry Delivery Considerations

### 14.4.1 Gantry Shipping State

The gantry ships with most covers installed, and the assembly mounted between two dollies (see [Figure 14-3 Gantry Shipping Dollies with Side Rails on page 158](#)). Two side rails, bolted to the dollies, stabilize the dollies and protect the gantry. Use the dolly elevating casters to lift the gantry off its base and roll it into position.

**Figure 14-3 Gantry Shipping Dollies with Side Rails**

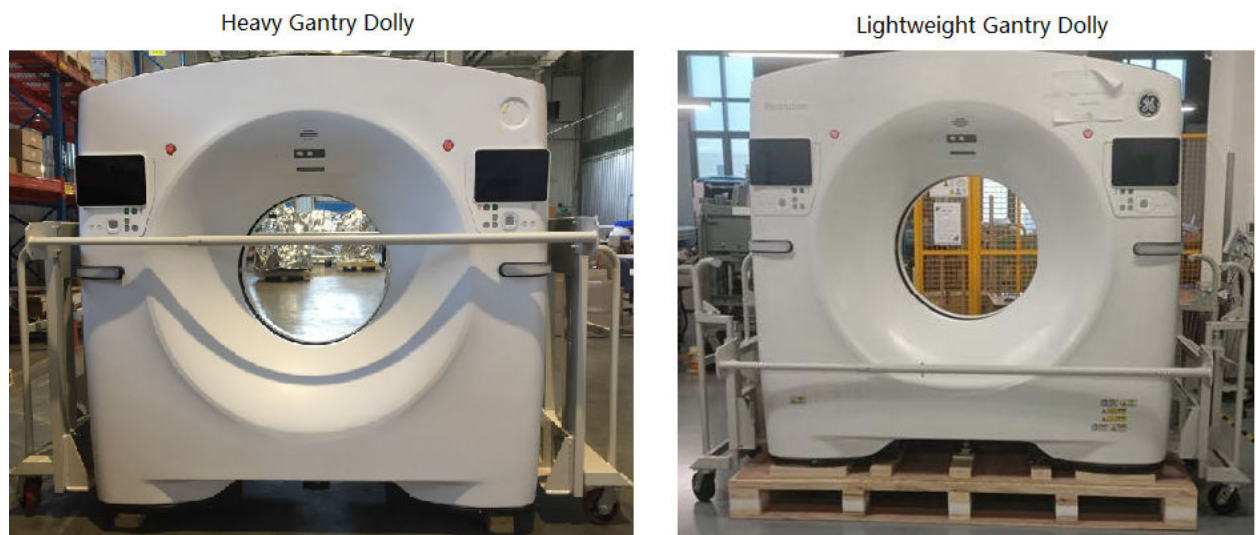

### 14.4.2 Door Openings

Unobstructed door openings, for moving equipment into the building, must measure 1067 mm X 2083 mm (42 in. X 82 in.) minimum. Corridors with a width of 2439 mm (8 ft.) also prove helpful.

### 14.4.3 Elevator Requirements

When moving the gantry from the receiving location to the scanning room, pay special attention to elevator size and capacity. Removing side rails and one dolly after placing the gantry in the elevator reduces the gantry width/length and elevator depth requirements.

Due to gantry component weight differences all weights listed below are averages. This change can measure  $\pm 18.14$  kg ( $\pm 40$  lb). Contact the elevator manufacturer if the gantry weight exceeds elevator capacity (see [Table 14-2 Size of Gantry & Dollies, with and without Side Rails on page 158](#)).

**Table 14-2 Size of Gantry & Dollies, with and without Side Rails**

Configuration	Length	Width	Height	Weight
Dollies On, Side Rails On	2775 mm (109 in.) to 2850 mm (112 in.)	1291 mm (51 in.)	2000 mm (79 in.)	1835 kg (4049 lb) 1757.8 kg (3875.3 lb) - lightweight dolly

**Table 14-2 Size of Gantry & Dollies, with and without Side Rails** (Table continued)

Configuration	Length	Width	Height	Weight
Dollies On, Side Rails Removed	2775 mm (109 in.) to 2850 mm (112 in.)	1014 mm (39.9 in.)*	2000 mm (79 in.)	1807 kg (3987 lb) 1731.9 kg (3818.2 lb) - lightweight dolly
Dollies Off, Covers Off	1938 mm (76 in.)	924 mm (36 in.)	1867 mm (74 in.)	1412 kg (3116 lb)

\*: the width size is not considering gantry dollies, and the actual size is gantry width, please refer to [Figure 7-1 Gantry with Covers Dimensions on page 47](#).

The minimum hallway and door size for a gantry with covers and dollies attached but side rails removed. For alternative lifting arrangements and instructions, contact GE Installation Support Services.

**Figure 14-4 Size of Gantry & Dollies**

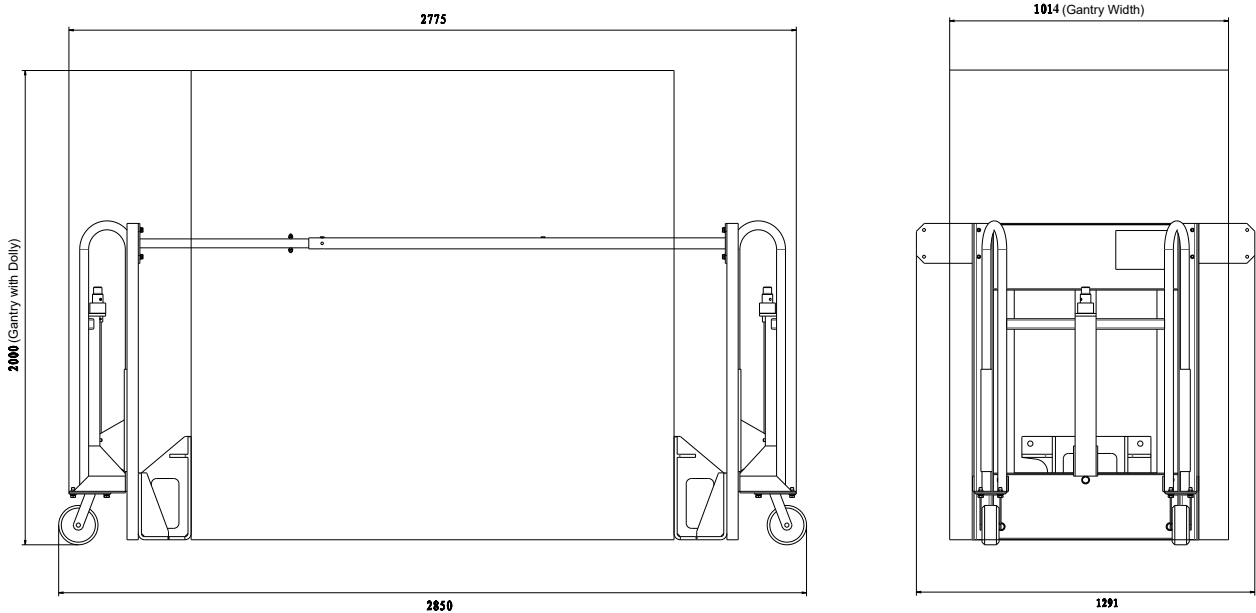

## 14.5 Table Delivery Considerations

### GT1700V/GT2000 Table:

The table is shipped without side covers installed. Covers are shipped in separate boxes. The table is mounted with two dollies.

### Lite Table:

The whole Lite table is shipped in one box. The side and base covers are disassembled and put on the table. The table is mounted between two dollies.

For the table with dollies dimensions, refer to [Table 14-3 Table Dimensions with dollies on page 160](#).

**Table 14-3 Table Dimensions with dollies**

	Length		Width		Height		Weight	
	mm	in	mm	in	mm	in	kg	lb
GT2000 Table	2997	118	762	30	1143	45	632	1392
GT1700V Table	2489	98	762	30	1143	45	576	1270
Lite Table	2440	96	818	32	1430	56	372	821

## 14.6 Console Delivery Considerations

The dimensions of console alone (as shipped): refer to [7.2.5 Console Dimensions on page 52](#).

## 14.7 Storage Requirements

### NOTICE

Failure to adhere to storage requirements can result in equipment damage.

### 14.7.1 Short-term Storage (Less than Six Months)

If storing the CT system before installation for less than six months, store it in a temperature- and humidity-controlled warehouse. Protect it from weather, dirt, and dust. Meeting the following requirements prevents rust and corrosion from forming on bearing surfaces due to condensation:

- Storage temperature should not exceed 0° to 30° C (32° to 86° F).
- Maintain relative humidity (non-condensing) up to 70%.
- Maximum rate of relative humidity change measures 5%/hr.
- Maximum rate of temperature change measures 3° C/hr. (5° F/hr.)
- Storage longer than 6 months is not recommended.

### NOTICE

Between delivery qualifies as short-term storage. Van storage must meet the same specifications listed above.

### 14.7.2 Construction-Site Storage

When storing the CT system at a construction site be sure to adhere to the following storage requirements:

- Do not damage or puncture the shipping crate.
- Do not remove packaging until all construction is completed at the site and all dust created by the construction is removed.
- Maintain a storage temperature within the range of 10° to 32° C (50° to 90° F).
- Maintain a relative humidity (non-condensing) between 20% and 70%.

## 14.8 Extreme Temperature Delivery and Storage



### CAUTION

Failure to adhere to extreme temperature requirements during delivery and storage can result in equipment damage.

Avoid extreme temperatures during system transportation and delivery.

Extreme temperatures consist of temperatures below  $-18^{\circ}\text{C}$  ( $0^{\circ}\text{F}$ ), or above  $49^{\circ}\text{C}$  ( $120^{\circ}\text{F}$ ), without humidity control.

When transporting the CT system, prevent extended exposure of the system to temperatures or humidity outside of the following specifications:

- Up to two weeks duration
- Temperature:  $-40^{\circ}$  to  $+70^{\circ}\text{C}$  ( $-40^{\circ}$  to  $+158^{\circ}\text{F}$ )
- Humidity: 10% to 100%, including condensing
- Altitude:  $-549\text{m}$  to  $5,486\text{m}$  ( $-1,800\text{ ft.}$  to  $18,000\text{ ft.}$ )

### NOTICE

Component freezing occurs when exposing the CT system to temperatures below  $-18^{\circ}\text{C}$  ( $0^{\circ}\text{F}$ ) for a period longer than two (2) days. Allow a minimum of 12 hours for the CT system to adjust to ambient room temperature prior to installation.

Page intentionally left blank

# 15 Handling Requirements

Communicate the information in this chapter to any personnel who will transport, move, or otherwise handle the system components during transportation and delivery of the system.

## 15.1 Transportation

To avoid dropping the gantry, it is recommended that the system is transported from GE to the facility of the installation site, shipping dock-to-dock in a van. However, facilities without a loading dock may transport the system using liftgate or flatbed trucks, provided that no dropping or mis-handling of the system occurs. These methods involve unloading system components from the truck and then rolling them across SMOOTH sidewalks or other paved surfaces.

## 15.2 Handling Requirements

The design of the system does not tolerate dropping, shock, vibration, tipping, or hoisting. Be sure to communicate these handling requirements to all parties involved in transporting, moving, and handling system components.

### 15.2.1 Avoid Dropping

Never drop the gantry, console, table, or PDU. A drop from a height greater than 13 mm (0.5 in.) may cause structural damage to the frame or other major components. Damage resulting from a drop (e.g., bent frame, misalignment) may not become apparent until after the system is installed.

### 15.2.2 Avoid Shocks and Vibrations

The design of the system, including the gantry, console, table, and PDU, does not tolerate excessive shock or vibration, which may occur during unloading. For example, rolling the console across a "washboard" style ramp may vibrate components, causing loose or broken connections. Damage resulting from shock or vibration (e.g., monitor, CD-ROM, hard-drive, or console failure) may not become evident until after the system is installed.

### 15.2.3 Avoid Tipping

All system components must remain upright at all times; avoid tipping them. Move the gantry by rolling it on its dollies ONLY, do NOT hoist it. Avoid tipping or lifting the gantry when moving it through hallways, doorways, elevators, etc.

#### **NOTICE**

Lifting the gantry requires engineering approval for each occurrence. Your GE PMI should contact CT Engineering for all special lifting requirements, as unauthorized gantry lifting can cause gantry bearing damage.

## 15.2.4 Flat-bed Truck Removal (NOT Approved Tilting)

Flat-bed Truck Removal wrecker, attach the straps to the LOWEST possible point on the dolly, and lower the gantry at the SLOWEST reasonable rate, (see [Figure 15-1 Proper Gantry Strap Location](#) on page 164).



Tilt-bed truck is no longer an approved delivery methods. It is allowed to use a tilt-bed truck (tilt disabled) as a flatbed truck and use a forklift or crane to unload a system.

**Figure 15-1 Proper Gantry Strap Location**

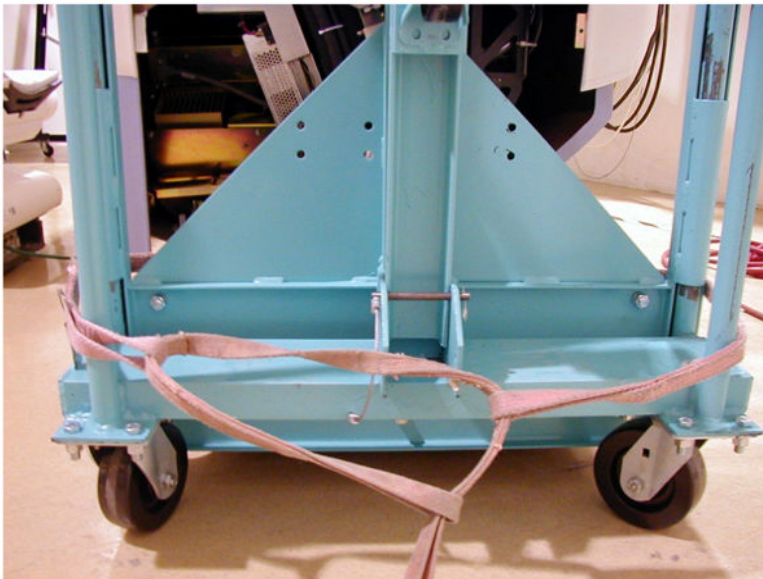

SOME ASSEMBLIES MAY BE TOP-HEAVY. BE CAREFUL NOT TO TIP!

# A Regulatory Clearances for US

## A.1 Regulations

Review all codes in your area prior to your installation date. US customers should consider these codes:

- 29 CFR 1910 (OSHA)
- NFPA 70E (Standard for Electrical Safety in the Workplace)
- NFPA 101 (Life Safety Code)
- Americans with Disabilities Act

### NOTICE

**All systems installed within the United States and United States territories, and within United States government facilities, regardless of country, must comply with all United States Federal and local regulations. All systems installed outside the United States must comply with either the national, state, or local regulatory clearance requirements for the country in which the installation occurs, or US Federal regulations, whichever is greater.**

## A.2 Clearance Requirements

A map of clearance requirements necessary for proper operation and servicing of the system is provided in below figures.



### NOTE

A similar map of detailed dimensional clearance measurements necessary for safe servicing of the system is provided in [Figure 5-1 Minimum Service Clearances on page 33](#).

### NOTICE

The maps and dimensions shown in this manual depict the required clearances for proper equipment operation and service only. The customer/ purchaser is responsible for federal, state, and local codes regarding facility egress and related facility requirements.

### NOTICE

The use of alternate layouts puts severe limitations on space for patient care and work flow. Customer approval of site drawings signifies customer agreement to these limitations.

## Condition References

There are three possible minimum service space requirements based on the construction of the wall directly adjacent to the side of the gantry. The following three conditions determine the minimum space requirement that would apply to the room based on the special conditions of the wall:

- **Condition 1** If the side of the system being serviced is directly facing an ungrounded surface of wall without live voltage panels and without surface mounted ducts or conduits the minimum space requirement is 914 mm (36 in).
- **Condition 2** If side of the system being serviced is directly facing a grounded surface of wall the minimum space requirement is 1067 mm (42 in).
- **Condition 3** If the side of the system being serviced is directly facing a surface of wall with live voltage panels, surface mounted ducts, or conduits the minimum space requirement is 1219 mm (48 in).

**Figure A-1 U.S. Regulatory Clearance Requirements for System with GT2000 Table**

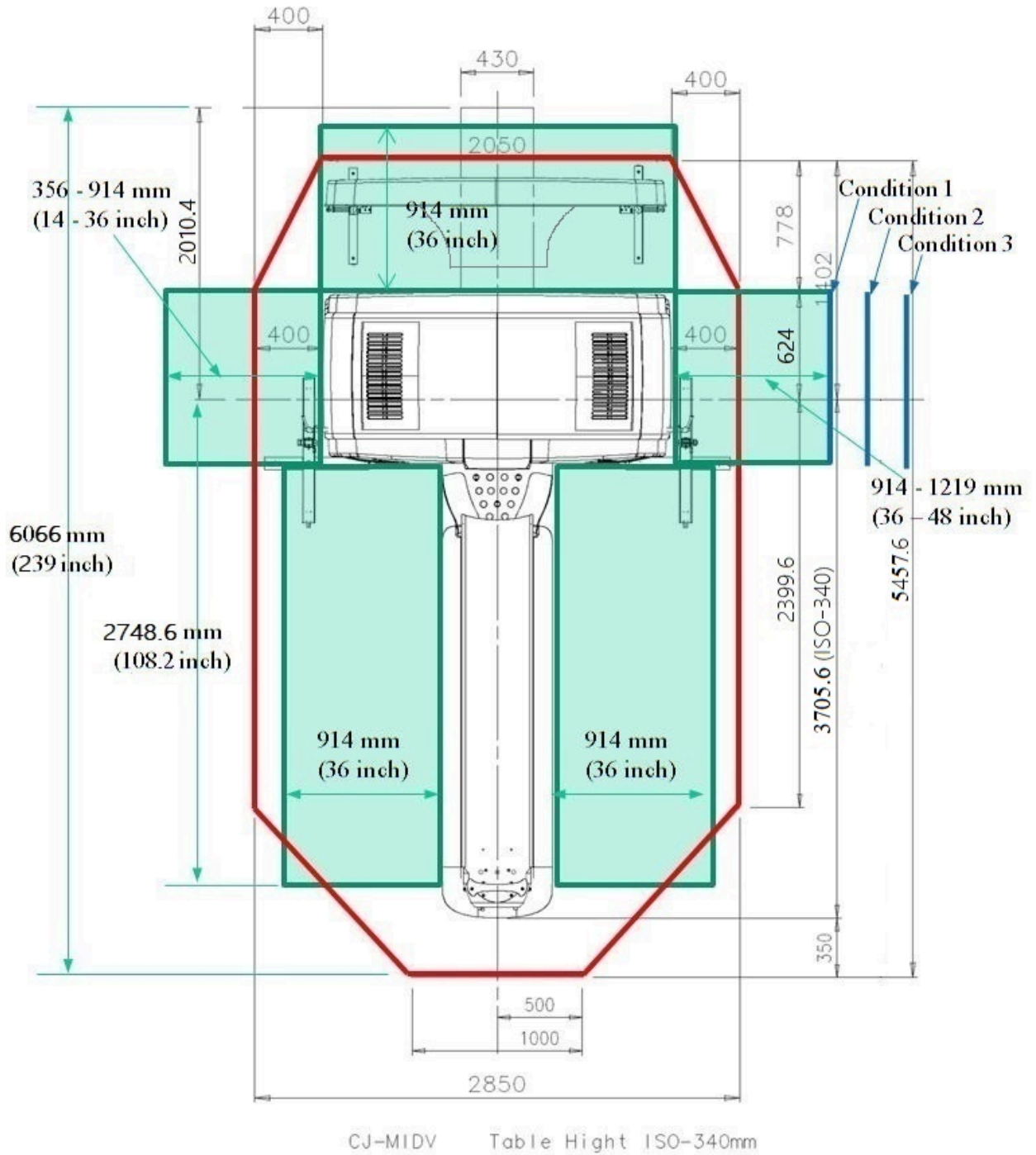

- Cover Removal Clearance
- Service Access Clearance

**NOTE:**

- Egress is not considered.
- Table Height : ISO -340 mm
- Unit: mm

**Figure A-2 U.S. Regulatory Clearance Requirements for System with GT1700V Table**

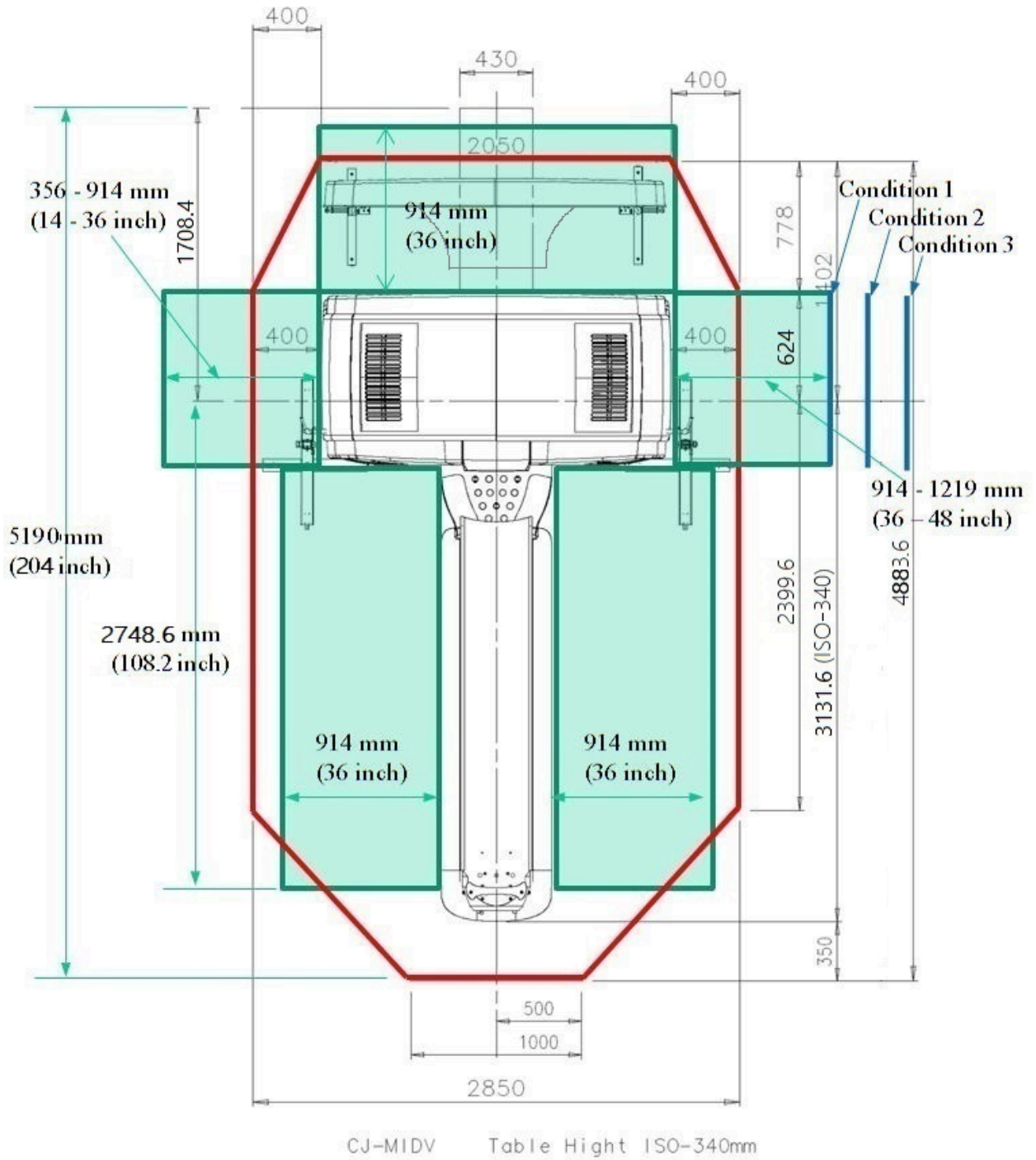

- Cover Removal Clearance
- Service Access Clearance

**NOTE:**

- Egress is not considered.
- Table Height : ISO -340 mm
- Unit: mm

**Figure A-3 U.S. Regulatory Clearance Requirements for System with Lite Table**

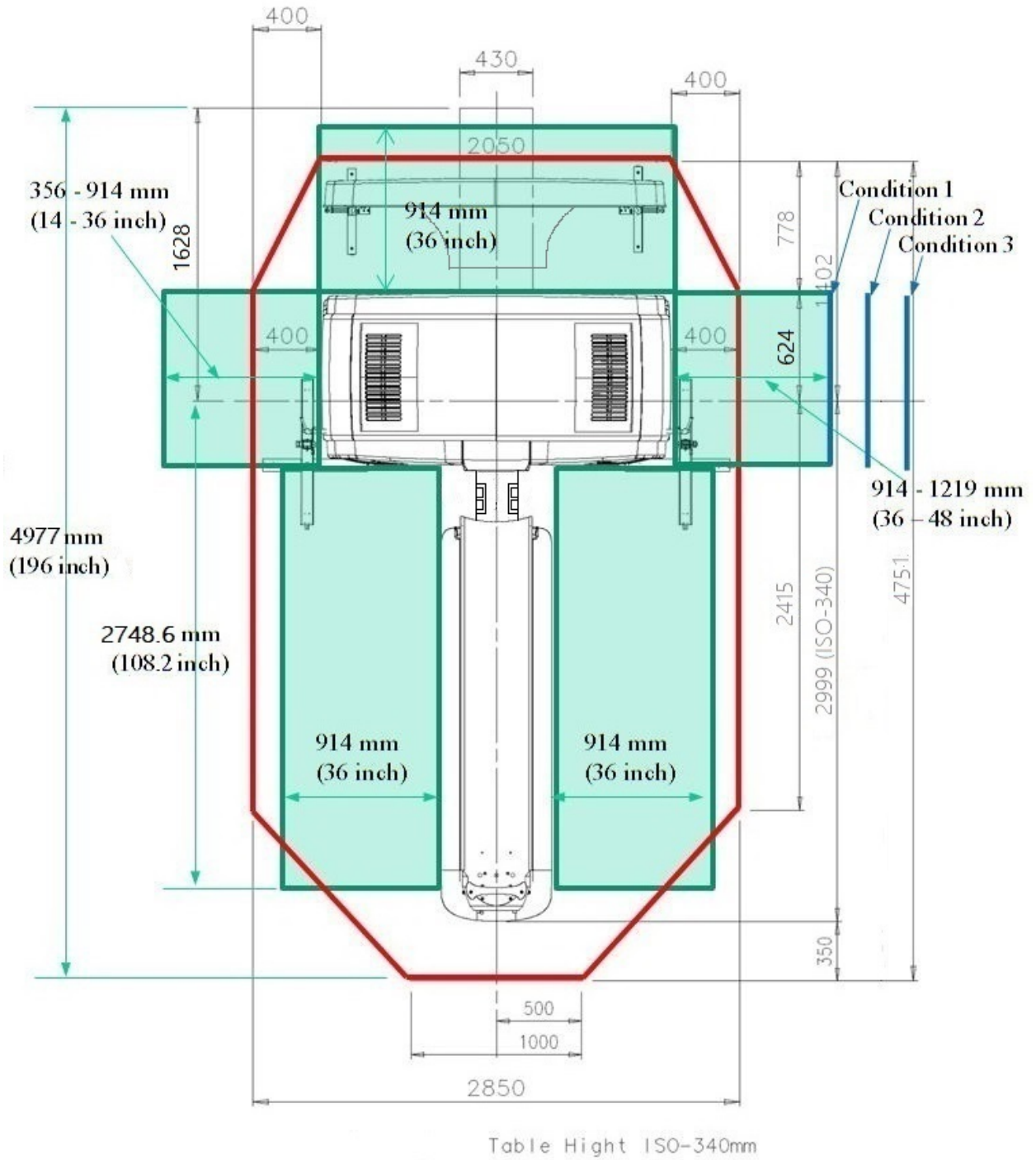

- Cover Removal Clearance
- Service Access Clearance

**NOTE:**

- Egress is not considered.
- Table Height : ISO -340 mm
- Unit: mm

## A.3 Minimum Regulatory Workspace Clearances by Major Subsystem

Note the following when referring to the tables below:

- These requirements apply to equipment operating at 600 V or less, where examination, adjustment, servicing, or maintenance is likely to be performed with live parts exposed.
- The customer **MUST** maintain the required regulatory clearance distances and may **NOT** use these area for storage. This applies during normal system operation as well as during service inspection and maintenance.
- Direction of Service Access refers to a direction perpendicular to the surface of the equipment serviced.

**Table A-1 CONSOLE – Minimum Workspace Clearances**

Workspace Requirement	Minimum Clear Space	Additional Conditions
Direction of Service Access (front and rear of console)	Not applicable. (no exposed live part hazards.)	
Service Access Width (front and back of work-space)		Refers to the width of the working space in front of equipment. 762 mm (30 in) minimum or the equipment width, whichever is greater.
Head Clearance	1981 mm (78 in.)	Refers to the height of the work-space measured from the floor at the front edge of the equipment to the ceiling or any overhead obstructions. 1981 mm (78 in) or the height of the equipment, whichever is greater.

### NOTE

Distances are measured to the finished covers.

**Table A-2 PDU – Minimum Workspace Clearances**

Workspace Requirement	Minimum Clear Space	Additional Conditions
Direction of Service Access (Front of PDU)	914 mm (36 in.)	1219 mm (48 in) if exposed live parts of 151-600 Volts are present on both sides of the work-space with the operator between. 1067 mm (42 in) if the opposite wall is grounded and exposed live parts of 151-600 Volts are present.
Service Access Width (Front of Work-space)	762 mm (30 in.)	Refers to the width of the working space in front of equipment. 762 mm (30 in) minimum or the equipment width, whichever is greater.
Head Clearance	1981 mm (78 in.)	Refers to the height of the work-space measured from the floor at the front edge of the equipment to the ceiling or any overhead obstructions. 1981 mm (78 in) or the height of the equipment, whichever is greater.

**NOTE**

For the Gantry and Table, distances are measured from the finished covers.

**Table A-3 GANTRY – Minimum Workspace Clearances**

Workspace Requirement	Minimum Clear Space	Additional Conditions
Direction of Service Access (All Sides)	914 mm (36 in.)	1219 mm (48 in), if exposed live parts of 151-600 V are present on both sides of the work-space with the operator between. 1067 mm (42 in), if the opposite wall is grounded and exposed live parts of 151-600 V are present.
Service Access Width (Left-Right of Workspace)	762 mm (30 in.)	Refers to the width of the working space in front of equipment. 762 mm (30 in) minimum or the equipment width, whichever is greater.
Head Clearance	1981 mm (78 in.)	Refers to the height of the work-space measured from the floor at the front edge of the equipment to the ceiling or any overhead obstructions. 1981 mm (78 in) of the height of the equipment, whichever is greater.

**Table A-4 TABLE – Minimum Workspace Clearances**

Workspace Requirement	Minimum Clear Space	Additional Conditions
Direction of Service Access (Table Head)	not applicable	
Direction of Service Access (Table Sides)	914 mm (36 in.)	Can be reduced to 711 mm (28 in) provided the local team obtains written and signed approval from the local AHJ (Authority Having Jurisdiction). GE must have the signed document on file.
Direction of Service Access (Table Foot)	711 mm (28 in.)	457 mm (18 in.) minimum for Front Gantry Cover removal, only if an unobstructed egress space of 711 mm (28 in.) exists around the equipment for room exit, and no trip hazards exist along the path of egress.
Service Access Width (Left-Right of Workspace)	762 mm (30 in.)	Refers to the width of working space in front of equipment. 762 mm (30 in) minimum or the equipment width, whichever is greater.
Head Clearance	1981 mm (78 in.)	Refers to the height of the work-space measured from the floor at the front edge of the equipment to the ceiling or any overhead obstructions. 1981 mm (78 in) minimum or the equipment height, whichever is greater.

**Table A-5 UPS – Minimum Workspace Clearances**

Workspace Requirement	Minimum Clear Space	Additional Conditions
Direction of Service Access (Front of UPS)	914 mm (36 in.)	There are no exposed live part hazards with the cover in place. This component is typically serviced from the front with access to the rear. * If exposed live parts of 151 - 600 volts are present, 1219 mm (48 in.) is required on both sides of the workspace with the operator between. * If the opposite wall is grounded and exposed live parts of 151 - 600 volts are present, 1067 mm (42 in.) is required.

**Table A-5 UPS – Minimum Workspace Clearances** (Table continued)

<b>Workspace Requirement</b>	<b>Minimum Clear Space</b>	<b>Additional Conditions</b>
Service Access Width (Left-Right of Workspace)	762 mm (30 in.)	Refers to the width of working space in front of equipment. 762 mm (30 in.) minimum or the equipment width, whichever is greater.
Head Clearance	1981 mm (78 in.)	Refers to the height of the work-space measured from the floor at the front edge of the equipment to the ceiling or any overhead obstructions. 1981 mm (78 in) minimum or the equipment height, whichever is greater.

**Table A-6 A1/MDP – Minimum Workspace Clearances**

<b>Workspace Requirement</b>	<b>Minimum Clear Space</b>	<b>Additional Conditions</b>
Direction of Service Access (Front of A1/MDP Disconnect)	914 mm (36 in.)	There are no exposed live part hazards with the cover in place. This component is typically serviced from the front with access to the rear. * If exposed live parts of 151 - 600 volts are present, 1219 mm (48 in.) is required on both sides of the workspace with the operator between. * If the opposite wall is grounded and exposed live parts of 151 - 600 volts are present, 1067 mm (42 in.) is required.
Service Access Width (Left-Right of Workspace)	762 mm (30 in.)	Refers to the width of working space in front of equipment. 762 mm (30 in.) minimum or the equipment width, whichever is greater.
Head Clearance	1981 mm (78 in.)	Refers to the height of the work-space measured from the floor at the front edge of the equipment to the ceiling or any overhead obstructions. 1981 mm (78 in) minimum or the equipment height, whichever is greater.

## A.4 How to Measure

Figure below offers guidance on the proper way to measure to check minimum regulatory clearances.

**Figure A-4 Measuring Minimum Regulatory Clearances**

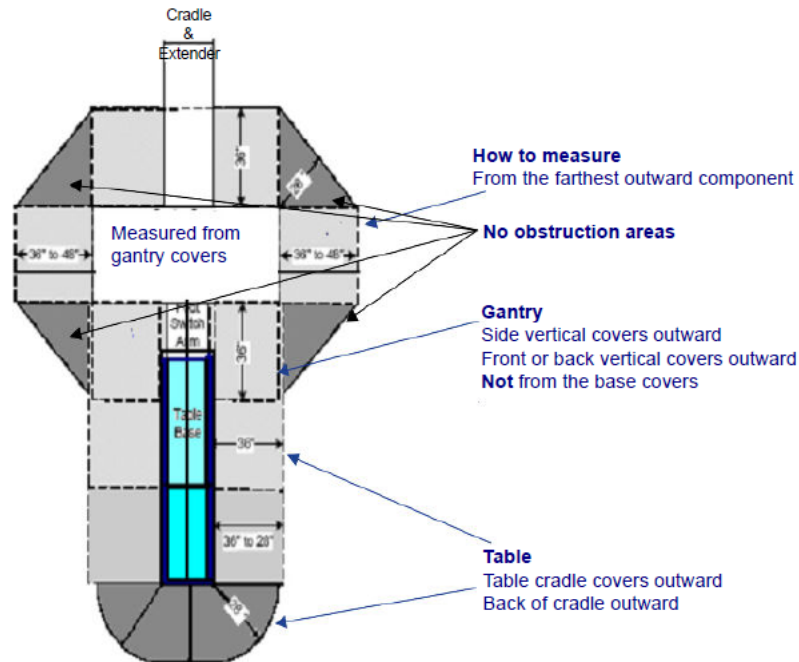

### ⚠ CAUTION



#### REGULATORY CAUTION

All system installations, relocations, and moves, require site prints. The CT room layout shall match the layout shown on your site print and meet all regulatory requirements described in the installation manual. Additional room components, such as cabinets and sinks, reduce room size. Consequently, equipment not shown on the site print may void the caution statement, making the room NON-COMPLIANT. Actual site measurements obtained by the mechanical installer before installation determines room size and compliance.

### ⚠ CAUTION



#### OPERATIONAL CAUTION

In the minimum room layout (356 mm to 686 mm [14 in. to 27 in.]) the customer should consider workflow, customer access for patient care, and critical-care operations space requirements. Additionally, this layout may offer only limited equipment access on the gantry left side when loading patients or when positioning patient equipment in the room between the gantry and the wall.

## A.5 NEC Conduit and Duct Fill Rate

Full operation, service, and safety of the system requires the maintenance of sufficient regulatory and service clearances around equipment.

Cable length is an important consideration in room layout. The system ships with standard (short) length cables, with a set of longer cables available as an option. Refer to the electrical page of your GE site print for the specific requirements of your site. The following rules govern cable usage for the system:

- When possible, use the rear cable cover assembly to let cables enter the gantry from the rear.
- Do not cut or otherwise shorten long cables.
- Do not store excess cable length behind the operator console, gantry, or PDU.
- Store excess cable in wall or floor ducts, if desired, provided that sufficient space exists. Refer to NEC code to determine cable fill rates for conduits and ducts.
- All installed systems shall comply with NFPA 70-E Electrical Regulations governing conduit or duct fill.

## B Alternate Cover Removal Options

### B.1 Overview

The room dimensions and clearance dimensions shown in this manual assume a room configuration in which the front and rear gantry covers are removed and stored straight back/ forward from the gantry. However, not all room configurations are the same, meaning covers can be stored in other available spaces. For example, some rooms are long and skinny, while other rooms are short and wide. Some rooms may have a support column in the way, while other rooms have an adjacent room to store the gantry covers. For this reason, some alternative cover removal options for different room configurations are presented in this appendix.

### B.2 Front Cover Removal

Rather than storing the front cover straight forward from the gantry at the foot of the table, the cover can be moved and stored on the right or left side of the table if there is space available while still maintaining service access to the table. Additionally, the cover can be moved out of the scan room to a temporary storage location.

The standard procedure for removing the front cover is with the table all the way down. A second method for front cover removal is with the table partially raised and the IMS moved into the bore of the gantry by table service switch. Under this method, the minimum length of the room can be reduced.

#### NOTICE

A room size that utilizes the table-up cover removal method has severe limitations in space for patient care and work flow. The map and dimensions shown in this manual depict the required clearances for proper equipment operation and service only. The customer/purchaser is responsible for federal, state and/or local codes regarding facility egress and related facility requirements.

### B.3 Rear Cover Removal

Rather than storing the rear cover straight back from the gantry, the cover can be moved and stored on the right or left side or angled if there is space available while still maintaining service access to the gantry. Additionally, the cover can be moved to the side of the table or out of the scan room to a temporary storage location.

For rooms with a surface floor duct (without ramps) behind the gantry, the rear cover cannot be moved to the side of the gantry. Due to the weight of the gantry cover, lifting it over a surface floor duct without ramps is prohibited.

Figure B-1 Cover Removal Clearance (GT2000 - Gantry Front Cover Removal and Storage to Left Side)

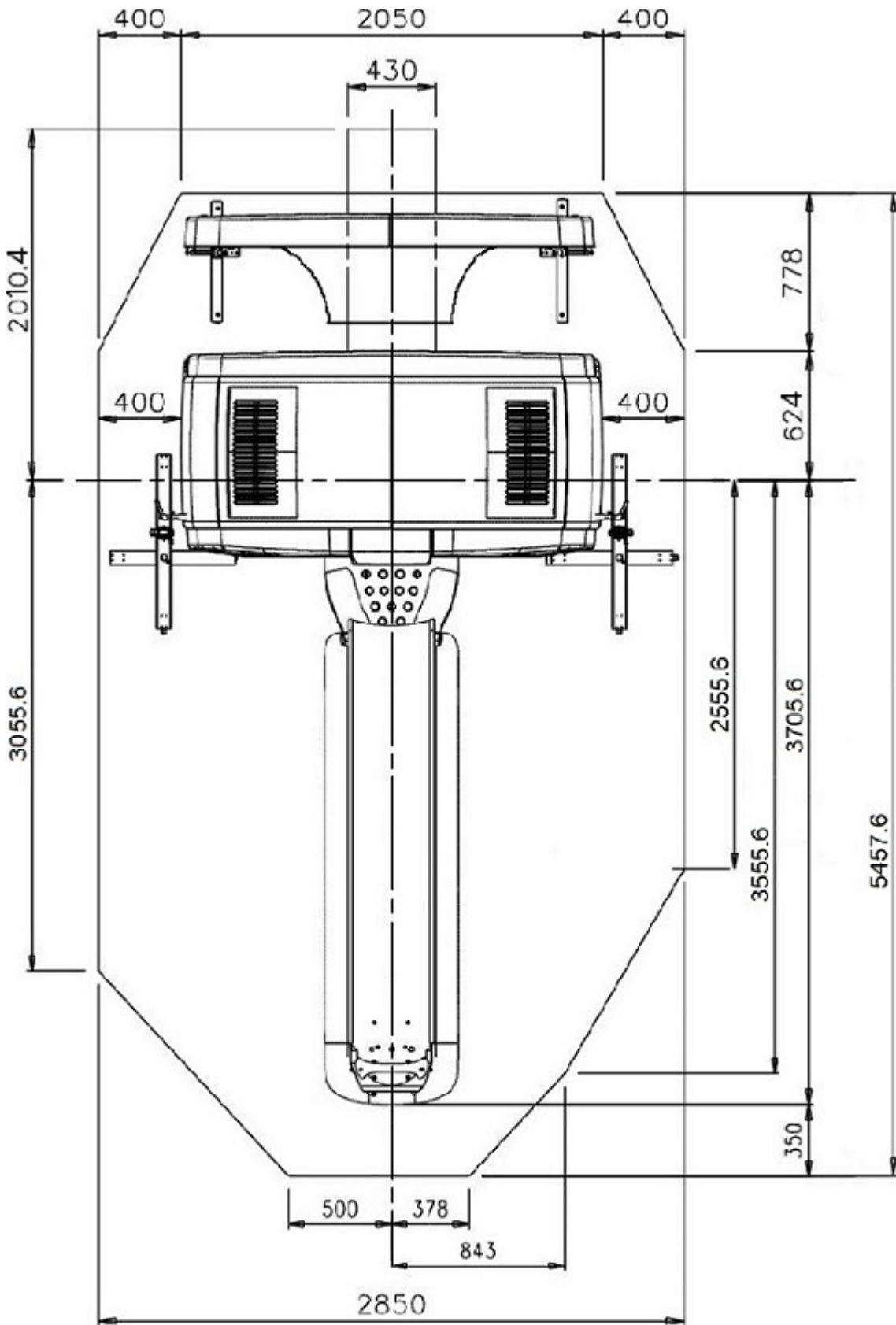

Table Height ISO-340mm

Figure B-2 Cover Removal Clearance (GT2000 - Gantry Front Cover Removal and Storage to Right Side)

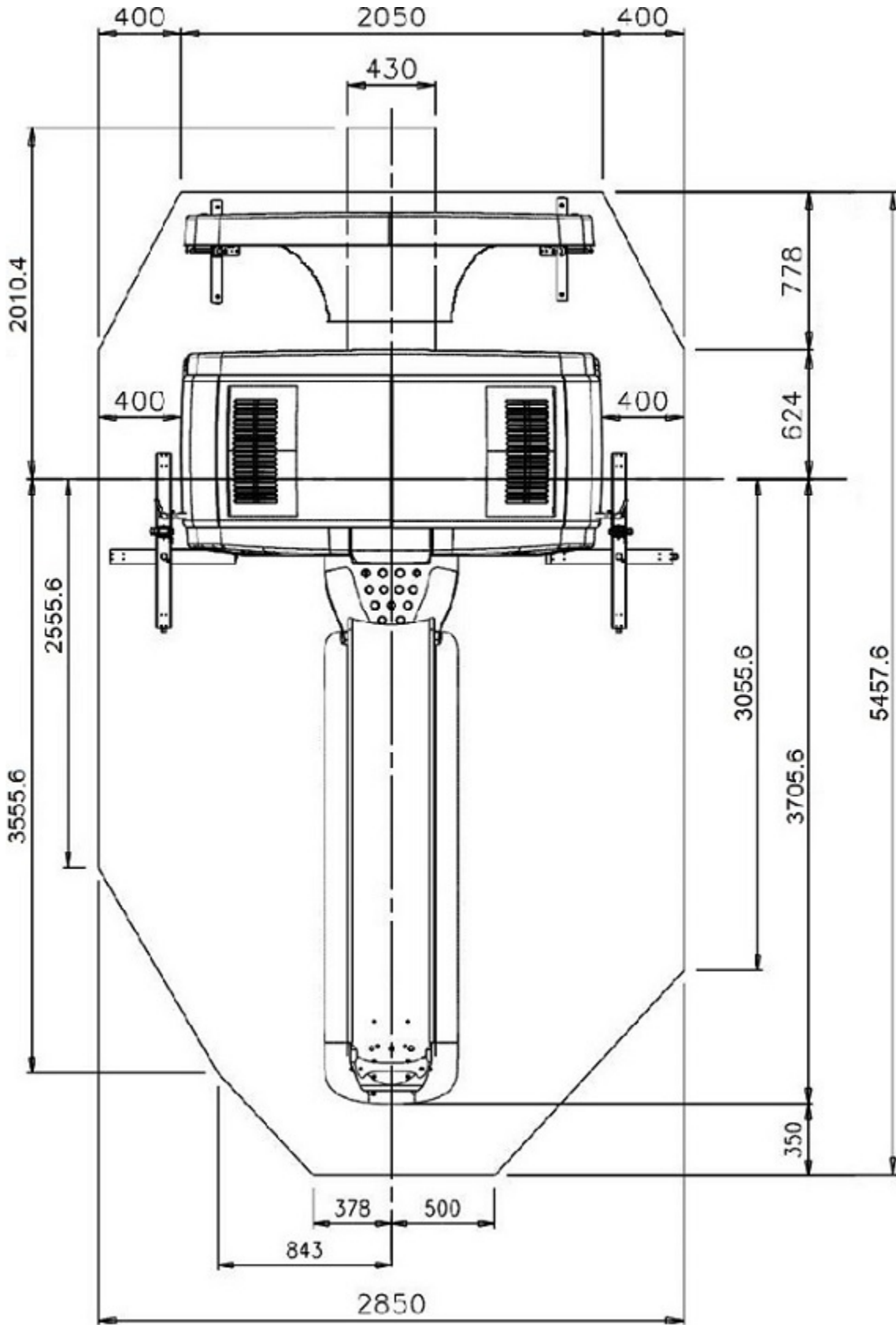
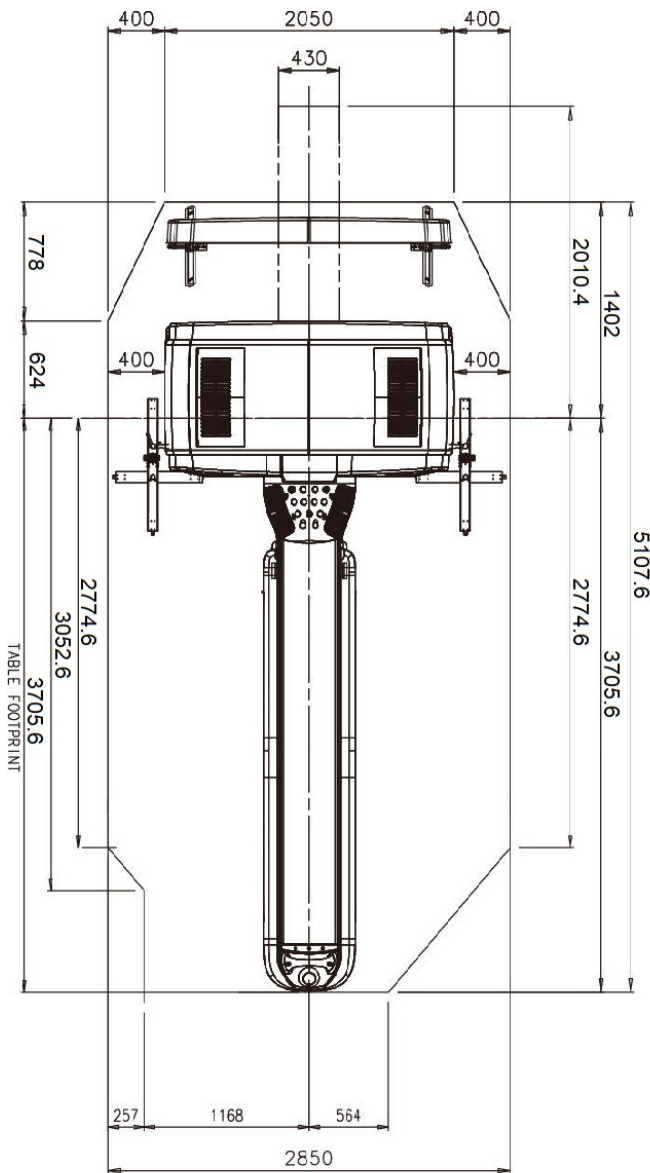

Table Hight ISO-340mm

**Figure B-3 Cover Removal Clearance (GT2000 - Gantry Front Cover Removal and Storage to Left Side with IMS Manually Moved In)**



Note:GT2000 IMS can moves 4000mm at IST-340.  
So if IMS is moved 4000mm In-direction by sevice switch, Gantry cover can be removed.



Figure B-5 Cover Removal Clearance (GT1700V - Gantry Front Cover Removal and Storage to Left Side)

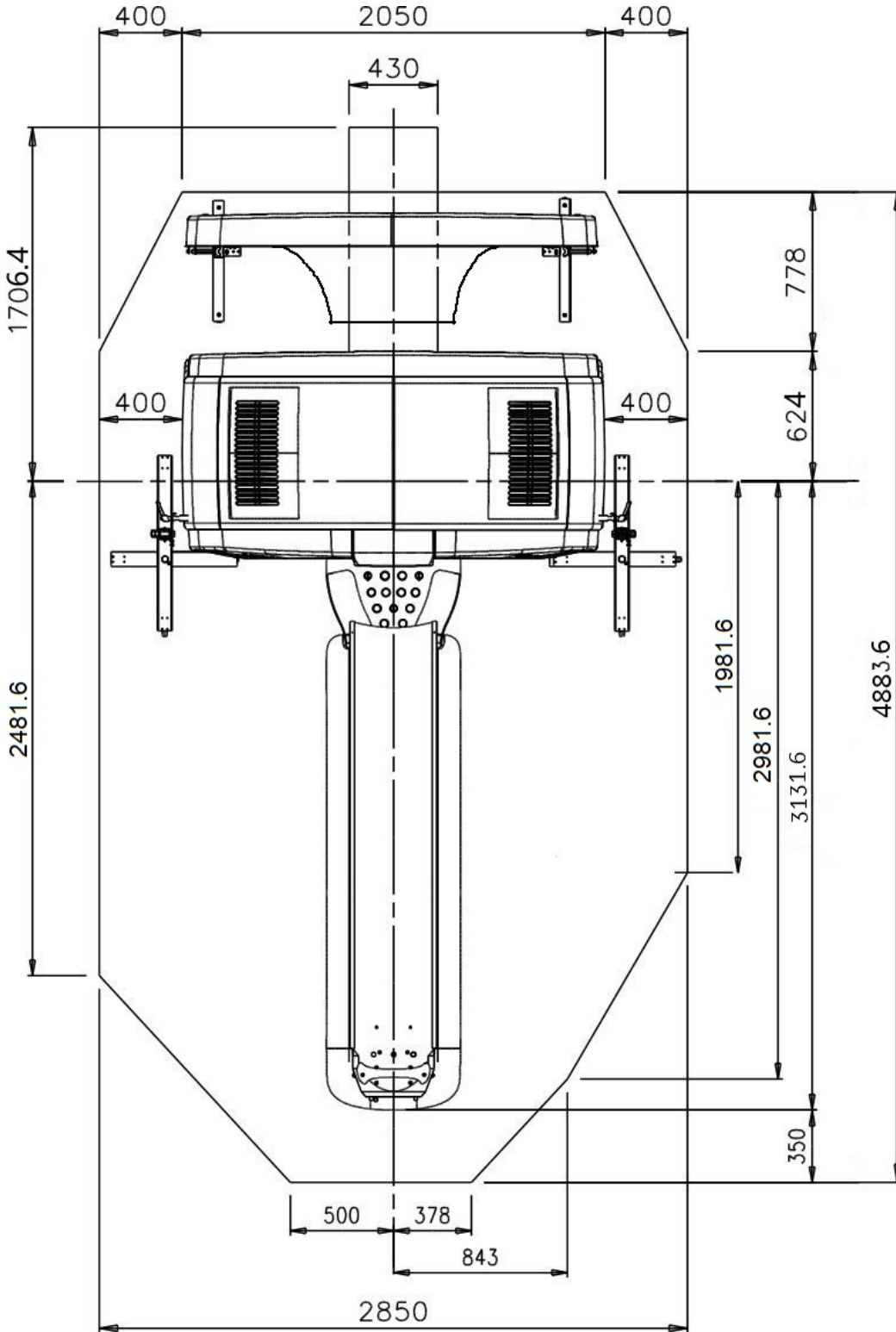

Table Height ISO-340mm

**Figure B-6 Cover Removal Clearance (GT1700V - Gantry Front Cover Removal and Storage to Right Side)**

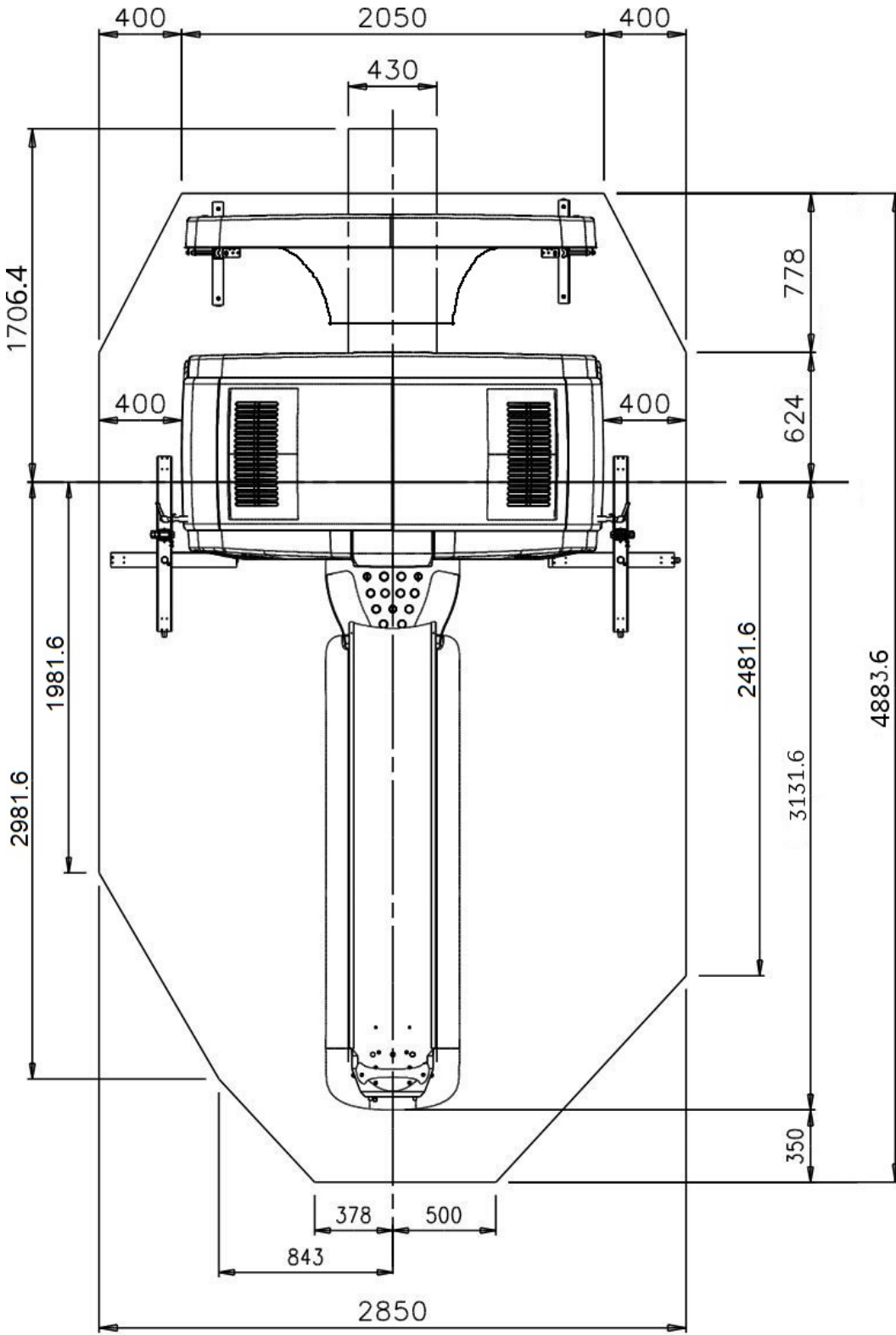

Table Hight ISO-340mm





Page intentionally left blank





GE HealthCare

[www.gehealthcare.com](http://www.gehealthcare.com)