

Revolution ACTs

Pre-Installation Manual

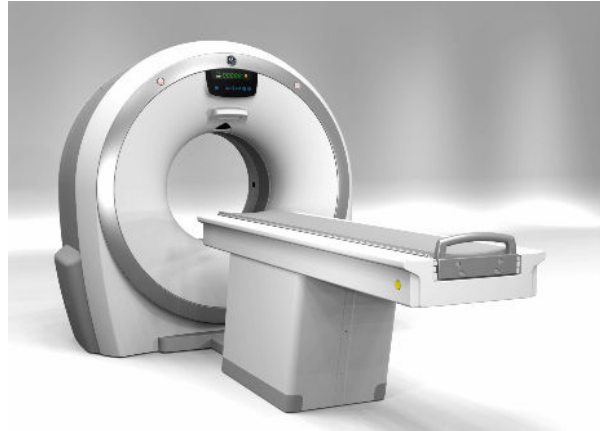

5487112-1EN
Revision 7
US English

Effectivity

- The information in this manual applies to Revolution ACTs Scanner.
- The information in this manual does NOT apply to non-fixed (mobile) installations.

Language Policy

DOC0371395 - Global Language Procedure

ПРЕДУПРЕЖ ДЕНИЕ (BG)	Това ръководство е налично само на китайски (ZH-CN), английски, френски, немски, японски, корейски, полски, португалски (PT-BR), руски, испански и виетнамски. Ако доставчикът на услуги на даден клиент изисква език, който е различен от тези езици, отговорност на клиента е да предостави преводачески услуги.
警告 (ZH-CN)	本手册仅提供中文 (ZH-CN)、英文、法语、德语、意大利语、日语、韩语、波兰语、葡萄牙语 (PT-BR)、俄语、西班牙语和越南语版本。如果客户的服务提供商需要其他语言，则客户有责任提供翻译服务。
警告 (ZH-HK)	本手冊僅提供中文 (ZH-CN)、英文、法文、德文、意大利文、日文、韓文、波蘭文、葡萄牙文 (PT-BR)、俄文、西班牙文及越南文版本。如客戶的服務供應商需要這些語言以外的版本，則相關客戶有責任提供有關的翻譯服務。
警告 (ZH-TW)	此手冊僅提供中文 (ZH-CN)、英文、法文、德文、義大利文、日文、韓文、波蘭文、葡萄牙文 (PT-BR)、俄文、西班牙文和越南文版本。假如客戶的服務提供者所需語言版本不在所列語言之中，客戶需自行負責提供翻譯服務。
UPOZORENJE (HR)	Ovaj je priručnik dostupan samo na kineskom (ZH-CN), engleskom, francuskom, njemačkom, talijanskom, japanskom, korejskom, poljskom, portugalskom (PT-BR), ruskom, španjolskom i vijetnamskom jeziku. Ako klijentov serviser zahtijeva jezik koji nije jedan od tih jezika, odgovornost je klijenta pružiti uslugu prevođenja.
VÝSTRAHA (CS)	Tato příručka je k dispozici pouze v čínštině (ZH-CN), angličtině, francouzštině, němčině, italštině, japonštině, korejštině, polštině, portugalštině (PT-BR), ruštině, španělštině a vietnamštině. Pokud poskytovatel služeb zákazníka vyžaduje jiný jazyk než tyto jazyky, je odpovědností zákazníka poskytovat překladatelské služby.
ADVARSEL (DA)	Denne vejledning findes kun på kinesisk (ZH-CN), engelsk, fransk, tysk, italiensk, japansk, koreansk, polsk, portugisisk (PT-BR), russisk, spansk og vietnamesisk. Hvis en kundes tjenesteudbyder kræver et andet sprog end disse sprog, er det kundens ansvar at levere oversættelsestjenester.
WAARSCHUW- ING (NL)	Deze handleiding is alleen beschikbaar in het Chinees (ZH-CN), Engels, Frans, Duits, Italiaans, Japans, Koreaans, Pools, Portugees (PT-BR), Russisch, Spaans en Vietnamees. Als de serviceprovider van een klant een andere taal dan deze talen vereist, is het de verantwoordelijkheid van de klant om vertaalservices te leveren.
WARNING (EN)	This manual is available in Chinese (ZH-CN), English, French, German, Italian, Japanese, Korean, Polish, Portuguese (PT-BR), Russian, Spanish, and Vietnamese only. If a customer's service provider requires a language other than these languages, it is the customer's responsibility to provide translation services.
HOIATUS (ET)	See juhend on saadaval ainult hiina (ZH-CN), inglise, prantsuse, saksa, itaalia, jaapani, korea, poola, portugali (PT-BR), vene, hispaania ja vietnami keeles. Kui kliendi teenusepakkujal on vaja juhendit mõnes muus keeles, on tõlketeenuste osutamine kliendi kohustus.
VAROITUS (FI)	Tämä opas on saatavilla vain kiinaksi (ZH-CN), englanniksi, ranskaksi, saksaksi, italiaksi, japaniksi, koreaksi, puolaksi, portugaliksi (PT-BR), venäjäksi, espanjaksi ja vietnamiksi. Jos asiakkaan palveluntarjoaja edellyttää muuta kuin näitä kieliä, käännöspalveluiden tarjoaminen on asiakkaan vastuulla.

Continues on the next page

ATTENTION (FR)	Ce manuel est disponible uniquement en allemand, anglais, chinois (ZH-CN), coréen, espagnol, français, italien, japonais, polonais, portugais (PT-BR), russe et vietnamien. Si le prestataire de services d'un client nécessite que le manuel soit rédigé dans une autre langue que celles mentionnées ci-dessus, il incombe au client de le faire traduire.
WARNUNG (DE)	Dieses Handbuch ist nur auf Chinesisch (ZH-CN), Englisch, Französisch, Deutsch, Italienisch, Japanisch, Koreanisch, Polnisch, Portugiesisch (PT-BR), Russisch, Spanisch und Vietnamesisch verfügbar. Wenn ein Dienstleister des Kunden dieses in einer anderen Sprache als die genannten benötigt, liegt es in der Verantwortung des Kunden, Übersetzungsdienstleistungen zu erbringen.
ΠΡΟΕΙΔΟΠΟΙΗΣΗ (EL)	Αυτό το εγχειρίδιο είναι διαθέσιμο μόνο σε Κινεζικά (ZH-CN), Αγγλικά, Γαλλικά, Γερμανικά, Ιταλικά, Ιαπωνικά, Κορεατικά, Πολωνικά, Πορτογαλικά (PT-BR), Ρωσικά, Ισπανικά και Βιετναμέζικα. Εάν ο πάροχος υπηρεσιών ενός πελάτη απαιτεί γλώσσα που δεν συμπεριλαμβάνεται σε αυτές τις γλώσσες, αποτελεί ευθύνη του πελάτη να παρέχει υπηρεσίες μετάφρασης.
FIGYELMEZTETÉS (HU)	Ez a kézikönyv az alábbi nyelveken érhető el: angol, francia, japán, kínai (ZH-CN), koreai, lengyel, német, olasz, orosz, portugál (PT-BR), spanyol és vietnámi. Ha az ügyfél szolgáltatója ezektől eltérő nyelvű kézikönyvet szeretne, akkor az ügyfél feladata, hogy gondoskodik a megfelelő fordításról.
ÁDVÖRUN (IS)	Þessi handbók er aðeins fánleg á kínversku (ZH-CN), ensku, frönsku, þýsku, ítölsku, japönsku, kóresku, pólsku, portúgölsku (PT-BR), rússnesku, spænsku og víetnömsku. Ef þjónustuaðili viðskiptavinar þarfnast annars tungumáls en þessara tungumála er það á ábyrgð viðskiptavinarins að veita þýðingarþjónustu.
AVVERTENZA (IT)	Questo manuale è disponibile solo in lingua cinese (ZH-CN), inglese, francese, tedesco, italiano, giapponese, coreano, polacco, portoghese (PT-BR), russo, spagnolo e vietnamita. Qualora un fornitore di servizi del cliente richieda una lingua diversa dall'inglese, sarà responsabilità del cliente fornire il servizio di traduzione corrispondente.
警告 (JA)	このマニュアルは、中国語 (ZH-CN)、英語、フランス語、ドイツ語、イタリア語、日本語、韓国語、ポーランド語、ポルトガル語 (PT-BR)、ロシア語、スペイン語、およびベトナム語のみで提供されています。お客様のサービスプロバイダがこれらの言語以外の言語を必要とする場合は、お客様の責任において翻訳サービスを提供してください。
경고 (KO)	이 설명서는 중국어(중국어-중국), 영어, 프랑스어, 독일어, 이탈리아어, 일본어, 한국어, 폴란드어, 포르투갈어(포르투갈어-브라질), 러시아어, 스페인어, 베트남어로만 제공됩니다. 고객의 서비스 제공자가 언어를 제외한 다른 언어를 요구하는 경우, 번역 서비스를 제공하는 것은 고객의 책임입니다.
BRĪDINĀJUMS (LV)	Šī rokasgrāmata ir pieejama tikai ķīniešu (ZH-CN), angļu, franču, vācu, itāliešu, japāņu, korejiešu, poļu, portugāļu (PT-BR), krievu, spāņu un vjetnamiešu valodā. Ja klientu apkalpošanas speciālistam ir nepieciešama cita valoda, kas atšķiras no šeit norādītajām, klienta pienākums ir nodrošināt tulkotājas pakalpojumu.
ĮSPĖJIMAS (LT)	Šis vadovas pateikiamas tik kinų (ZH-CN), anglų, prancūzų, vokiečių, italų, japonų, korėjiečių, lenkų, portugalų (PT-BR), rusų, ispanų ir vietnamiečių kalbomis. Jei klientų paslaugų teikėjui reikalinga kita nei šios kalba, už vertimo paslaugų suteikimą atsako klientas.
ADVARSEL (NO)	Denne håndboken er bare tilgjengelig på kinesisk (ZH-CN), engelsk, fransk, tysk, italiensk, japansk, koreansk, polsk, portugisisk (PT-BR), russisk, spansk og vietnamesisk. Hvis en kundes tjenesteleverandør krever et annet språk, er det kundens ansvar å levere en oversettelsestjeneste.
OSTRZEŻENIE (PL)	Niniejsza instrukcja jest dostępna wyłącznie w języku chińskim (ZH-CN), angielskim, francuskim, niemieckim, włoskim, japońskim, koreańskim, polskim, portugalskim (PT-BR), rosyjskim, hiszpańskim i wietnamskim. Jeśli usługodawca klienta wymaga języka, który nie został wymieniony powyżej, obowiązkiem klienta jest zapewnienie usług tłumaczeniowych.
ATENÇÃO (PT-BR)	Este manual está disponível somente em chinês (ZH-CN), inglês, francês, alemão, italiano, japonês, coreano, polonês, português (PT-BR), russo, espanhol e vietnamita. Se o prestador de serviços de um cliente necessitar de um idioma diferente dos mencionados, o fornecimento dos serviços de tradução é de responsabilidade do cliente.

Continues on the next page

ATENÇÃO (PT-PT)	Este manual está disponível apenas em alemão, chinês (ZH-CN), coreano, espanhol, francês, inglês, italiano, japonês, polaco, português (PT-BR), russo e vietnamita. Se o fornecedor de serviços de um cliente necessitar de um idioma diferente dos listados aqui, é da responsabilidade do cliente assegurar os serviços de tradução.
ATENȚIE (RO)	Acest manual este disponibil numai în limbile chineză (ZH-CN), engleză, franceză, germană, italiană, japoneză, coreeană, poloneză, portugheză (PT-BR), rusă, spaniolă și vietnameză. Dacă furnizorul de servicii al unui client solicită o limbă diferită față de aceste limbi, este responsabilitatea clientului să furnizeze servicii de traducere.
ОСТОРОЖНО! (RU)	Настоящее руководство доступно только на китайском (ZH-CN), английском, французском, немецком, итальянском, японском, корейском, польском, португальском (PT-BR), русском, испанском и вьетнамском языках. Если поставщику услуг заказчика требуется руководство на каком-либо другом языке, перевод руководства на необходимый язык осуществляется стороной заказчика.
UPOZORENJE (SR)	Ovaj priručnik dostupan je samo na kineskom (ZH-CN), engleskom, francuskom, nemačkom, italijanskom, japanskom, korejskom, poljskom, portugalskom (PT-BR), ruskom, španskom i vijetnamskom jeziku. Ako korisnik kao pružalac usluge zahteva neki drugi jezik od navedenih, njegova je dužnost da obezbedi prevod.
UPOZORNENIE (SK)	Táto príručka je dostupná len v nasledovných jazykoch: čínština (ZH-CN), angličtina, francúzština, nemčina, taliančina, japončina, kórejščina, poľština, portugalčina (PT-BR), ruština, španielčina a vietnamčina. Ak poskytovateľ služieb daného zákazníka požaduje iný ako tieto jazyky, za poskytnutie prekladateľských služieb zodpovedá zákazník.
ATENCION (ES)	Este manual está disponible solo en chino (ZH-CN), inglés, francés, alemán, italiano, japonés, coreano, polaco, portugués (PT-BR), ruso, español y vietnamita. Si el proveedor de servicios de un cliente requiere un idioma distinto de estos idiomas, es responsabilidad del cliente proporcionar los servicios de traducción.
VARNING (SV)	Den här manualen finns endast tillgänglig på kinesiska (ZH-CN), engelska, franska, tyska, italienska, japanska, koreanska, polska, portugisiska (PT-BR), ryska, spanska och vietnamesiska. Om en kunds tjänsteleverantör behöver ett annat språk än dessa är det kundens ansvar att ordna med översättningstjänster.
OPOZORILO (SL)	Ta priročnik je na voljo v kitajščini (ZH-CN), angleščini, francoščini, nemščini, italijanščini, japonščini, korejščini, poljščini, portugalščini (PT-BR), ruščini, španščini in vietnamščini. Če kupčev ponudnik storitev potrebuje drug jezik, mora za prevod poskrbeti kupec.
DİKKAT (TR)	Bu kılavuz yalnızca Çince (ZH-CN), İngilizce, Fransızca, Almanca, İtalyanca, Japonca, Korece, Lehçe, Portekizce (PT-BR), Rusça, İspanyolca ve Vietnamca dillerinde mevcuttur. Müşteri servis sağlayıcısı bu dillerden başka bir dil talep ederse çeviri hizmeti sağlamak müşterinin sorumluluğundadır.
ЗАСТЕРЕЖЕННЯ (UK)	Цей посібник доступний лише китайською (ZH-CN), англійською, французькою, німецькою, італійською, японською, корейською, польською, португальською (PT-BR), російською, іспанською та в'єтнамською мовами. Якщо постачальник послуг замовника використовує мову, яку не вказано у цьому переліку, послуги з перекладу має забезпечити замовник.

Damage in Transportation

All packages should be closely examined at time of delivery. If damage is apparent, have notation "damage in shipment" written on all copies of the freight or express bill before delivery is accepted or "signed for" by a GE HealthCare representative or a hospital receiving agent. Whether noted or concealed, damage MUST be reported to the carrier immediately upon discovery, or in any event, within 14 days after receipt, and the contents and containers held for inspection by the carrier. A transportation company will not pay a claim for damage if an inspection is not requested within this 14 day period.

To file a report:

- Fill out the GIQ workflow for any items missing, damaged, OBF/FOI for in process installs: https://bpm.gehealthcare.com/prweb/PRAuth/app/GIQ/o8uZcrjyYhEANdV611UguQ*/!STANDARD?pzuiactionzzz=CXtpbn15MzhRL0lCNINZTkJXUG5PTkJwNVZYbFhhYnlwSHM4SXVOU0RqaHhNOENwL1B6RW1XSEtnY1RDZjNuZXIKTThJSkpTYIUvNEdwRIE1UmpwTUthcVBSQT09*
- Contact your local service coordinator for more information on this process.

Certified Electrical Contractor Statement

All electrical Installations that are preliminary to positioning of the equipment at the site prepared for the equipment shall be performed by licensed electrical contractors. In addition, electrical feeds into the Power Distribution Unit shall be performed by licensed electrical contractors. Other connections between pieces of electrical equipment, calibrations and testing shall be performed by qualified GE HealthCare personnel. The products involved (and the accompanying electrical installations) are highly sophisticated, and special engineering competence is required. In performing all electrical work on these products, GE will use its own specially trained field engineers. All of GE's electrical work on these products will comply with the requirements of the applicable electrical codes.

The purchaser of GE equipment shall only utilize qualified personnel (i.e., GE's field engineers, personnel of third-party service companies with equivalent training, or licensed electricians) to perform electrical servicing on the equipment.

IMPORTANT ... X-Ray Protection

X-ray equipment if not properly used may cause injury. Accordingly, the instructions herein contained should be thoroughly read and understood by everyone who will use the equipment before you attempt to place this equipment in operation. The GE HealthCare will be glad to assist and cooperate in placing this equipment in use.

Although this apparatus incorporates a high degree of protection against x-radiation other than the useful beam, no practical design of equipment can provide complete protection. Nor can any practical design compel the operator to take adequate precautions to prevent the possibility of any persons carelessly exposing themselves or others to radiation.

It is important that anyone having anything to do with x-radiation be properly trained and fully acquainted with the recommendations of the National Council on Radiation Protection and Measurements as published in NCRP Reports available from NCRP Publications, 7910 Woodmont Avenue, Room 1016, Bethesda, Maryland 20814, and of the International Commission on Radiation Protection, and take adequate steps to protect against injury.

The equipment is sold with the understanding that the GE HealthCare, its agents, and representatives have no responsibility for injury or damage which may result from improper use of the equipment.

Various protective materials and devices are available. It is urged that such materials or devices be used.

Lithium Battery Cautionary Statements

CAUTION



RISK OF EXPLOSION.

Danger of explosion if battery is incorrectly replaced.

Replace only with the same or equivalent type recommended by the manufacturer. Discard used batteries according to the manufacturer's instructions.

WARNING



DANGER D'EXPLOSION

Il y a danger d'explosion s'il y a remplacement incorrect de la batterie.

Remplacer uniquement avec une batterie du même type ou d'un type recommandé par le constructeur. Mettre au rebut les batteries usagées conformément aux instructions du fabricant.

Omissions & Errors

Customers, please contact your GE Sales or Service representatives.

GE personnel, please use the Healthcare PQR Process to report all omissions, errors, and defects in this publication.

Revision History

Revision	Date	Reason for change
1	June 18, 2015	Initial Release
2	30-Jun-16	Product globalization
3	04-Jul-17	HP Z440 added to product configuration (as per ECR2227094).
4	30-Dec-18	For Edition 4.0 Compliance, Updated Chapter 9: Environmental Requirements, Section 5.0: Electro-Magnetic Compatibility (EMC) (Reference IEC 60601-1-2) Section 5.1 - The system complies with IEC60601-1-2 Edition 4.0 [2014] Section 5.2 - Updated Table 9.4 Section 5.3 - Updated Table 9.5
5	06-Aug-19	Import Precautions: DAMAGE IN TRANSPORTATION - Updated the Web link. Updated Chapter 1: Environmental Requirements Section 4.0: Changed from Customer Pre-Installation Tasks to Pre-Installation Checklist and Updated Checklist details. Chapter 3 - System Siting Requirements: Updated Section 2.3.3 Finished Floor Requirements Chapter 5: Service Clearance Requirements Updated Figure 5-1 Minimum Service Clearances

Continues on the next page

		<p>Updated Figure 5-2 Boom Assembly Clearance</p> <p>Updated Figure 6-3 Minimum Room Size for Revolution ACTs with Axial Head Holder (without PDA Option)</p> <p>Updated Figure 6-4 Minimum Room Size for Revolution ACTs with Axial Head Holder (with PDA Option)</p> <p>Chapter 7 - System Component Dimensions</p> <p>Updated Figure 7-2 Aakash Table and Gantry</p> <p>Chapter 11 Network Requirements</p> <p>Added new Section 3.0: Digital Service and Connectivity Requirements</p> <p>Chapter 9: Environmental Requirements, Updated Section 3.0: Altitude: Removed "Altitudes above 2,400 m (7,874 ft) require engineering approval."</p> <p>Chapter 13 - Interconnection Data</p> <p>Updated Table 13-2 GE Supplied Cables (Standard Run, Short) - UL Information</p> <p>Updated Table 13-6 Contractor-Supplied Components</p> <p>Chapter 14 - Delivery and Storage Requirements</p> <p>Section 3.1: Updated Text "The gantry ships with most covers installed"</p> <p>Added Figure 14-2 Gantry with Front and Back Covers</p> <p>Section 3.3: Updated Table 14-1 Size of Gantry & Dollies</p> <p>Section 7.0: Extreme Temperature Delivery and Storage, updated Notice.</p>
6	24-Dec-2020	<p>Chapter 1 - Introduction</p> <p>Updated Table 1-2 Required Information for Site on page 16</p> <p>Chapter 5 - Service Clearance Requirements</p> <p>Updated 5.2.2 Cover Removal on page 40</p> <p>Chapter 7 - System Component Dimensions</p> <p>Updated Figure 7-5 Operator's Console on page 56.</p> <p>Chapter 8 - Structural and Mounting Requirements</p> <p>Updated Table 8-2 Revolution ACTs Component Weight and Floor Loading Data on page 63.</p> <p>Updated Figure 8-7 Aakash Table Center of Gravity with 180kg Load Capacity on page 68</p> <p>Chapter 9 - Environmental Requirements</p> <p>Updated Table 9-3 System Heat Output on page 71</p> <p>Chapter 12 - Power Requirements</p> <p>Updated Table 12-2 Minimum Feeder Wire Size on page 89 and Table 12-3 Minimum Sub-Feeder Wire Size on page 90</p> <p>Chapter 13 - Interconnection Data</p> <p>Figure 13-1 System Interconnect Diagram of Short Cables (Standard)-For Host PC's - Z420/Z440/Z4G4 on page 93</p> <p>Chapter 14 - Delivery and Storage Requirements</p> <p>Updated Figure 14-1 Gantry with Shipping Dollies on page 102</p>
7	21-May-2025	<p>Updated Damage in Transportation on page 4</p>

Continues on the next page

	<p>Chapter 5 - Service Clearance Requirements Updated 5.2.2 Cover Removal on page 40</p> <p>Chapter 7 - System Component Dimensions Updated Figure 7-5 Operator's Console on page 56.</p> <p>Chapter 8 - Structural and Mounting Requirements Updated Table 8-2 Revolution ACTs Component Weight and Floor Loading Data on page 63.</p> <p>Chapter 9 - Environmental Requirements Updated Table 9-3 System Heat Output on page 71</p> <p>Chapter 10 - Radiation Protection Requirements Updated Figure 10-1 Typical stray radiation in μGy per 100mAs –Horizontal plane for body on page 81 and Figure 10-2 Typical stray radiation in μGy per 100mAs –Vertical plane for body on page 82</p> <p>Chapter 11 Network Requirements Updated 11.3.1 Background on page 84 and 11.3.2 InSite RSVP Connectivity Requirements (applicable on systems with software version 19IW19.XX and later only) on page 85</p> <p>Chapter 13 - Interconnection Data Updated Figure 13-1 System Interconnect Diagram of Short Cables (Standard)- For Host PC's - Z420/Z440/Z4G4 on page 93. Added Figure 13-2 System Interconnect Diagram of Short Cables (Standard)- For Host PC Z4G5 on page 94. Updated Table 13-3 GE Supplied Console Cables on page 94.</p> <p>Chapter 14 - Delivery and Storage Requirements Updated 14.5 Console Delivery Considerations on page 104.</p>
--	---

Contents

1 Introduction	14
1.1 What is Pre-Installation?	14
1.2 What is Pre-Installation Work?	14
1.3 Pre-Installation Tools	14
1.4 Roles and Responsibilities	15
1.5 Pre-Installation Checklist	16
2 Installation Types	20
2.1 How to Determine the Best Installation Type for Your Site	20
2.2 Typical Installations	20
2.3 Construction Site Installations	20
2.3.1 Full Construction Site with Completed Radiology Area	21
2.3.2 Full Construction Site with Limited Delivery Access	21
2.4 Relocatable Building Installations	21
2.5 Upgrade Installations	22
2.6 Quick Installations	22
2.7 Two-Step (Temporary) Installations	23
3 System Siting Requirements	24
3.1 System Siting Requirements	24
3.2 Customer System Siting Requirements	24
3.2.1 Regulatory Requirements	25
3.2.2 Electrical	25
3.2.3 Structural	25
3.2.3.1 Dust and Air Quality	26
3.2.3.2 Environmental Influences	26
3.2.3.3 Finished Floor Requirements	26
3.2.3.4 Finished Walls Requirements	28
3.2.4 Radiation Protection	28
3.2.5 Environmental	28
3.2.6 Options	29
3.2.7 Clearances	29
3.2.8 Network	29
3.2.9 Chemical Contamination	29
3.2.10 Delivery	29
3.3 Site Readiness	29
3.3.1 Pre-Installation Tasks	29
4 Regulatory Requirements	31
4.1 Regulatory Clearances	31
4.1.1 Regulations	31

4.1.2 Clearance Requirements.....	31
4.1.3 Minimum Regulatory Workspace Clearances by Major Subsystem	32
4.1.4 How to Measure.....	35
4.1.5 NEC Conduit and Duct Fill Rate	36
4.2 Regulatory Terms and Definitions	36
5 Service Clearance Requirements	39
5.1 Service Clearance Requirements.....	39
5.2 Service Clearances	40
5.2.1 Gantry Service Clearance for Tube and Detector Replacement.....	40
5.2.2 Cover Removal	40
5.2.3 Power Distribution Unit (PDU).....	41
5.2.4 Console	41
5.2.5 System Accessory.....	42
6 Room Sizes.....	43
6.1 Room Dimensions	43
6.1.1 Suggested Room Size.....	43
6.1.2 Typical Room Size	43
6.1.3 Minimum Room Size	44
6.2 Suggested and Typical Room Layouts without PDA.....	44
6.3 Suggested and Typical Room Layouts with PDA.....	45
6.4 Minimum Room Layouts without PDA Option	46
6.5 Minimum Room Layouts with PDA Option.....	47
6.6 Control Room Considerations	48
6.6.1 Typical Control Room Layout	49
6.6.1.1 Console Considerations.....	49
6.7 Patient Environment	49
7 System Component Dimensions	51
7.1 Minimum Operating Clearances	51
7.1.1 Ceiling Pedestal Mount Installation	51
7.1.2 System Operational Clearances	51
7.2 Component Dimensions	52
7.2.1 Gantry Dimensions	52
7.2.2 Table and Gantry Dimensions	53
7.2.3 Power Distribution Unit Dimensions.....	54
7.2.4 Power Distribution Adapter Dimensions.....	55
7.2.5 Console Dimensions	56
7.2.6 Console Desk Dimensions	57
8 Structural and Mounting Requirements	58
8.1 Overview.....	58
8.1.1 Importance of Meeting Structural Requirements.....	58
8.1.1.1 Levelness, Vibration, and Floor Loading.....	58

8.1.1.2	Seismic Loading	58
8.1.1.3	Anchoring	58
8.2	Ceiling Requirements	59
8.2.1	Electrical Box Requirement	59
8.3	Minimum Floor Requirements	59
8.3.1	Floor Levelness Specifications	59
8.3.1.1	Critical Specifications	59
8.3.1.2	Floor Levelness Guidelines	59
8.3.1.3	Measuring Floor Levelness	60
8.3.2	Walls	60
8.3.2.1	Scan Window	60
8.3.3	Floor Vibration Specifications	60
8.3.3.1	Requirements	60
8.3.3.2	Sources of Floor Vibration	62
8.4	Floor Loading and Component Weights	62
8.4.1	Floor Loading and Anchoring Guidelines	63
8.5	GE-Supplied Anchoring	64
8.5.1	Specifications of GE-supplied Anchors	64
8.5.2	Requirements for Using GE-supplied Anchors	65
8.6	Seismic Mounting	67
8.6.1	Overview	67
8.6.2	Center-of-Gravity Information	67
9	Environmental Requirements	70
9.1	Temperature and Humidity Specifications	70
9.1.1	Temperature (Scan and Control Rooms)	70
9.1.2	Humidity (Scan Room & Control Room)	70
9.1.3	Other Guidelines	70
9.2	Cooling Requirements	71
9.3	Altitude	72
9.4	Electro-Magnetic Interference (EMI)	72
9.4.1	Gantry	72
9.4.2	Console / Computer Equipment	73
9.4.3	PDU and PDA	73
9.4.4	EMI Reduction	73
9.4.5	Equipment EMI "Envelopes"	74
9.5	Electro-Magnetic Compatibility (EMC)(Reference IEC 60601-1-2)	74
9.5.1	General Scope	74
9.5.2	Electromagnetic Emission (Reference IEC 60601-1-2)	75
9.5.3	Electromagnetic Immunity (Reference IEC 60601-1-2)	75
9.5.4	Installation Requirements and Environment Control	77
9.6	System Component Noise Levels	78
10	Radiation Protection Requirements	79
10.1	Shielding Requirements	79

11 Network Requirements.....	83
11.1 Network Connections	83
11.1.1 Network Type	83
11.1.2 Network Speed.....	83
11.1.3 Network Cable Routing.....	83
11.2 Customer Broadband Responsibilities.....	84
11.2.1 Contact GE to Find Zone Broadband Specialist.....	84
11.2.2 Provide GE with IT Contact Information for the Site	84
11.3 Digital Service and Connectivity Requirements	84
11.3.1 Background	84
11.3.2 InSite RSVP Connectivity Requirements (applicable on systems with software version 19IW19.XX and later only)	85
12 Power Requirements	86
12.1 Introduction.....	86
12.2 System Input Power	86
12.2.1 Power Source Configuration.....	86
12.2.2 PDA Rating/NGPDU Rating.....	86
12.2.3 PDU Rating	87
12.2.4 System Rating.....	87
12.2.5 Regulation	87
12.2.6 Phase Imbalance	87
12.2.7 Sags, Surges and Transients	88
12.2.8 Grounding.....	88
12.3 Recommended Power Distribution System	88
12.3.1 Using a Dedicated Distribution Transformer (Recommended).....	88
12.3.2 Using an Existing Distribution Transformer	88
12.3.3 System Power Requirements	89
13 Interconnection Data	91
13.1 Introduction.....	91
13.2 Component Designators	91
13.3 Interconnect Runs, Wiring and Cables	92
13.3.1 GE Supplied (Standard, Short Length 5490840) (Reference IEC 60601-1-2 6.8.3.201)	92
13.3.2 GE Supplied (Console Cables)	94
13.3.3 Contractor/Customer-Supplied.....	95
13.3.4 Fuse.....	97
13.4 Contractor Supplied Components	97
13.5 Scan Room Warning Light and Door Interlock.....	98
14 Delivery and Storage Requirements	99
14.1 Delivery Types and System Lifting and Rigging Restriction	99
14.1.1 Loading Dock Deliveries	99
14.1.2 Ground (Non-Loading Dock) Deliveries	99

14.1.2.1	Liftgate Truck	99
14.1.2.2	Tiltbed Truck - NOT Approved	100
14.1.2.3	Forklift Truck	100
14.1.2.4	Rigging.....	100
14.2	Delivery to the Scan Suite	101
14.2.1	Lifting.....	101
14.2.1.1	Stairway Deliveries	101
14.2.2	Floor Protection	101
14.2.3	Un-loading and un-packing the System	101
14.3	Gantry Delivery Considerations.....	102
14.3.1	Gantry Shipping State.....	102
14.3.2	Door Openings	103
14.3.3	Elevator Requirements	103
14.4	Table Delivery Considerations	104
14.5	Console Delivery Considerations.....	104
14.6	Storage Requirements.....	104
14.6.1	Short-term Storage (Less than Six Months)	104
14.6.2	Construction-Site Storage	105
14.7	Extreme Temperature Delivery and Storage	105
15	Handling Requirements	106
15.1	Transportation.....	106
15.2	Handling Requirements	106
15.2.1	Avoid Dropping.....	106
15.2.2	Avoid Shocks and Vibrations	106
15.2.3	Avoid Tipping	106

1 Introduction

This document contains the physical and electrical data necessary for planning and preparing a site for system installation. The responsibility of arranging and paying for this work rests solely with the purchaser.

1.1 What is Pre-Installation?

Pre-installation is any site preparation required prior to the installation of the system. This manual states all pre-installation siting and regulatory requirements. The Pre-Installation Kit may not answer all of your questions, contact your GE Project Manager of Installation (PMI) for answers. Likewise, prior to any construction or approval, GE Headquarters Architectural Planning must review all CT site plans, preliminary concepts, and final working drawings. Contact your GE Project Manager of Installation (PMI) for complete information regarding your site-specific room layout.

1.2 What is Pre-Installation Work?

Pre-Installation work includes:

- Site renovation.
- Alterations or modifications to products not specifically included in the sales contract.
- Installation of electrical conduit, junction boxes, ducts, outlets, and line safety switches.
- Installation of AWG stranded copper interconnection wiring, conforming to the following requirements:
 - The electrical contractor shall ring out and tag all wires at both ends.
 - Wires shall be continuous and without splices.
 - Ground wires shall conform to product requirements.
 - Color-coded wires shall be used whenever possible, to enable easier identification.
- All work shall conform to IBC (International Building Code) and local building and safety codes.



NOTE

GE neither provides nor installs the wires, conduits, junction boxes, or ducts illustrated in this publication, unless specifically mentioned.

1.3 Pre-Installation Tools

A list of primary customer tools for successfully completing the pre-installation process for a Revolution ACTs system is described below.

Customer Pre-Installation Task

- Customer Pre-Installation Tasks
- Regulatory and Service Clearance Information

- **Floor Template (P/N: 5505704)**
Included with system, and also available from your PMI. Use this to determine equipment layout and anchoring locations.
- **Site Print**
Supplied by your PMI or sales rep. Must show actual room size, location of all equipment in the finished room, all service and operating clearances, and meet all regulatory requirements

Pre-Installation Manual Guide

Table below shows the location of the information necessary for fulfilling each of the pre-installation requirements.

Table 1-1 Locations of Site Requirement Information in this manual

Installation Site Requirement Information	
2.1 How to Determine the Best Installation Type for Your Site on page 20	3 System Siting Requirements on page 24
6.1 Room Dimensions on page 43	8 Structural and Mounting Requirements on page 58
4 Regulatory Requirements on page 31	5 Service Clearance Requirements on page 39
10 Radiation Protection Requirements on page 79	11 Network Requirements on page 83
9 Environmental Requirements on page 70	12 Power Requirements on page 86
14 Delivery and Storage Requirements on page 99	15 Handling Requirements on page 106
Contractors must complete ALL WORK before the scheduled delivery date.	

1.4 Roles and Responsibilities

- **Customer** : Also known as Buyer or Purchaser or End User. This is the entity that has entered into contract with GE to buy the product.
- **GE Salesperson** : Responsible for completing the customer order process. They coordinate the completion of customer order as desired by the customer, for the customer. They are responsible for correcting incorrect orders. Changing orders, coordinating any replacement of damage in shipment items and for resolving missing in shipment issues.
- **GE Project Manager of Installation (PMI)** : Responsibilities include the overall project coordination and site planning of GE products; manages activities cross-functionally with sales, customer, customer contractors, and local field teams to ensure customer site is designed and prepared to accept and install product in the facility.
- **GE Field Engineer** : GE field personnel responsible for the actual assembly, installation, calibration of the product and verification of the proper operation and configuration of the GE product. This may include the physical movement of the system and its subcomponents from the point of delivery to the scan suite.
- **Zone Broadband Specialist** : GE personnel responsible for providing IT expertise and maintaining records of specific network IT connectivity parameters that are required to properly configure the products' connection to the broadband connection provided by the customer.
- **Network IT Personnel** : Dedicated on site personnel affiliated with or contracted by the customer. Responsible for providing IT expertise necessary to ensure successful network IT connectivity between the GE product and the facility.

- **Qualified Electrician** : Also known as Electrical Contractor. Qualified (Certified by a regulatory agency), In-House individual or entity contracted by the customer. Responsible for electrical connections between customer power source and up to and including the final connection to the GE product.
- **Architectural Engineer** : Dedicated on site personnel affiliated with the customer or contracted by the customer to manage the details of the construction parameters defined by regulatory agencies and as defined by parameters in the GE Pre-installation manual for the proper installation of the GE product.
- **Structural Engineer** : Dedicated on site personnel affiliated with the customer or contracted by the customer to manage the details of the structural parameters defined by regulatory agencies and as defined by the structural parameters provided in the GE Pre-installation manual for the proper installation of the GE product.
- **HVAC Design Engineer** : Dedicated on site personnel affiliated with the customer or contracted by the customer to manage the details of the air conditioning and air handling parameters defined by regulatory agencies and as defined by parameters in the GE Pre-installation manual for the proper installation of the GE product.
- **Independent Contractor** : Person or entity who contracts to do work for another person according to his or her own processes and methods; the contractor is not subject to another's control except for what is specified in a mutually binding agreement for a specific job. Can be contracted by GE personnel or by the customer for a unique or special task as part of the GE product installation process.
- **Customer provided Project Coordinator** : Dedicated contact person that works with GE Project Manager (PM). Acts as the single point of contact for the customer. Coordinates with all persons or entities contracted by the customer for the successful installation of a GE product.
- **Rigger** : Person, persons or entity hired as an Independent Contractor to perform a specific task related to the movement of GE product from the point of delivery to the scan suit where it will be installed.

1.5 Pre-Installation Checklist

Table 1-2 Required Information for Site

Global Site Readiness Checklist (DI)		
Customer Name:	PMI Name:	
GON Number:	Field Service Name:	
Equipment:	Country/City or City/State:	
Site Visit Date for SRC:	SRC Status:	
Site Ready Checks for Equipment Delivery to Storage	Requirements Met	Comments
Sufficient & secured storage space is planned with the customer.		
Environmental requirements for storage place are met per GE requirements.		
All permits, plans and permissions received for rigging and/or delivery.		

Continues on the next page

Table 1-2 Required Information for Site (Table continued)

Global Site Readiness Checklist (DI)		
Rooms that will contain equipment, including staging areas if applicable, are dust free. Precautions must be taken to prevent dust from entering rooms containing equipment.		
Delivery route from truck to installation space has been reviewed, all communications have occurred, arrangements made for special handling (if needed). Floors along delivery route will support weight of the equipment, reinforcements arranged if needed.		
All floors along delivery route will support weight of the equipment, temporary reinforcements arranged if needed.		
Site Ready Checks at Installation	Requirements Met	Comments
EHS Site Requirements Requirements verified at final Site Readiness Checklist completion (Moment in Time)		
Overall access route to the scan room free from obstruction / high hazards.		
Enough space to store tools, equipment, parts, install waste and the general area free from obstruction and trip hazards.		
Enough necessary facilities for the GE employees available.		
No 3rd parties working in the area that may affect the safety of the installation activity.		
Area free from any chemical, gas, dust, welding fume exposure and has painting been completed and dry.		
All emergency routes identified, signed and clear from obstruction.		
Accessible single source lockable panel that LOTO can be applied to for GE equipment installation (MDP and/or PDU).		
There are no other conditions or hazards that you have observed or have been made aware of by the customer or contractors on site.		
Required for Mechanical Install start		
Room dimensions, including ceiling height, for all Exam, Equipment/Technical & Control rooms meets GE specifications.		
Ceiling support structure, if indicated on the GE drawing, is in the correct location and at the correct height according to the Original Equipment Manufacturer specifications.		
Levelness and spacing has been measured, and is ready for the installation of any GE supplied components.		
Overhead support Structure (unistrut) has been confirmed with customer/contractor to meet required GE provided criteria.		
Finished ceiling is installed. If applicable ceiling tiles installed per PMI discretion.		

Continues on the next page

Table 1-2 Required Information for Site (Table continued)

Global Site Readiness Checklist (DI)		
Floor levelness/flatness is measured and within tolerance, and there are no visible defects per GEHC specifications.		
Entry door threshold meets PIM requirement.		
Floor Strength and thickness have been discussed with customer/contractor and they have confirmed GE requirements are met.		
Rooms that will contain equipment, including staging areas if applicable, are construction debris free. Precautions must be taken to prevent debris from entering rooms containing equipment.		
Cable ways (floor/wall/ceiling/Access Flooring) are available for installation of GE cables are of correct length and diameter.		
Cable ways routes per GE Final drawings and cable access openings areas installed at a time determined by GEHC PM. Surface floor duct can be installed at time of system installation.		
Adequate room illumination installed and working.		
Adequate delivery route from truck to final place of installation has been reviewed with all stakeholders, all communications/notifications have occurred.		
Arrangements have been made for special handling (rigging, elevator, fork lift, etc.) All floors along delivery route will support weight of the equipment, temporary reinforcements arranged if needed.		
Customer supplied countertops where GE equipment will be installed are in place.		
Required for Calibration Start		
HVAC systems Installed, and the site meets minimum environmental operational system requirements.		
System power & grounding (PDB/MDP) is available as per GE specifications.		
System power & grounding (PDB/MDP) is installed at point of final connection and ready to use. Lock Out Tag Out is available.		
PMI to confirm all feeder wires and breaker are size appropriately. EPO installed if needed.		
PMI to confirm with electrician all power and signal cables are well terminated ensuring there are no loose connections.		
System power and grounded audit has been scheduled to be completed during installation of equipment. (If Required) GEHC PM to confirmed if needed.		
Network outlets installed.		
Computer network available and working.		

Continues on the next page

Table 1-2 Required Information for Site (Table continued)

Global Site Readiness Checklist (DI)		
Hospital IT/connectivity contacts have been engaged and information has been added to Project management tool. (If Required)		
Lead doors and windows complete or scheduled to be installed. If applicable, radiation protection (shielding) finished & radioprotection regulatory approval for installation obtained.		
PMI Signature:		
Customer Signature:		
FS Signature: optional		

2 Installation Types

2.1 How to Determine the Best Installation Type for Your Site

Discuss installation options with your PMI to determine which of the installation types listed below best fits your site and schedule.

- [2.2 Typical Installations on page 20](#)
- [2.3 Construction Site Installations on page 20](#)
- [2.4 Relocatable Building Installations on page 21](#)
- [2.5 Upgrade Installations on page 22](#)
- [2.6 Quick Installations on page 22](#)
- [2.7 Two-Step \(Temporary\) Installations on page 23](#)

2.2 Typical Installations

Typical installations occur at established sites with finished, dust-free, occupancy-ready scan suites. The rooms range from suggested to minimum room sizes, and have NO ongoing construction on-site. A typical installation allows customers flexibility for room upgrades and site improvements. Upgrades and improvements may require additional planning prior to system delivery, especially when involving:

- Seismic approval
- Floor structural improvements
- HVAC improvements
- Electrical improvements
- Review of scan room shielding requirements by a qualified radiological health physicist.

As with any installation, the final site design for a typical installation must meet all service and regulatory requirements detailed in this manual.

2.3 Construction Site Installations

A *construction installation* describes installation at sites without an occupancy permit, often with ongoing construction. In general, construction sites fail to meet the recommended specifications for delivery of the system. GE does not recommend construction installations, as they can result in delays, increased costs, and possible damage to the system. When construction-site delivery proves unavoidable, the installation falls into one of two categories.

- Full construction site with completed radiology area.
- Full construction site with limited delivery access.

Review the following categories to determine which most closely matches the condition of the planned installation site.

2.3.1 Full Construction Site with Completed Radiology Area

This type of site consists of a finished, dust-free, occupancy-ready radiology suite. While there is no remaining construction in or around the scan suite area, there may be ongoing construction in other areas. At the time of delivery such sites feature:

- Dust control measures deployed in the radiology suite area.
- Scan suite access limited to a single entrance (see [Figure 2-1 Full construction site with completed radiology area on page 21](#)).
- Radiology suite sealed off from the remaining construction area.
- Operational HVAC, with a positive air pressure within the radiology suite.

In addition the radiology suite at such a site REMAINS in a dust-free, occupancy-ready state after delivery and throughout the remaining construction phase.

Figure 2-1 Full construction site with completed radiology area

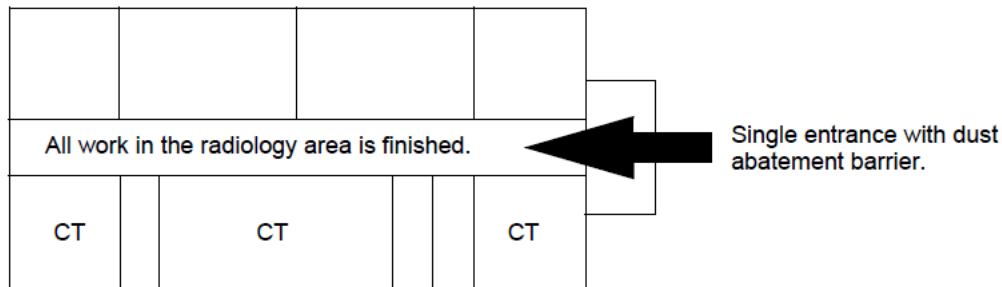

2.3.2 Full Construction Site with Limited Delivery Access

This type of site allows delivery during ongoing construction of the radiology suite area. At such sites, delivery occurs prior to site completion, but the product remains stored until a finished, dustfree, occupancy-ready radiology suite area is ready. This type of site requires the system scanner to be delivered in a sealed package with dollies. Delivery to the storage area may require a lift truck or riggers. Installation work begins only when the site reaches the completed, dust-free, occupancy-ready radiology suite requirement.

NOTE

If delivery requires vertical or horizontal lifting, the PMI adds the necessary identifier to the order.

2.4 Relocatable Building Installations

A re-locatable building is made in a factory and delivered to the site of its permanent location. Relocatable buildings qualify as fixed sites and must satisfy all of the requirements of a fixed site. The gantry and table must be mounted on a solid concrete floor. Any other floor type installations must be designed by the customer’s structural engineer and meet all GE Healthcare’s specifications listed in this manual.

Refer to the [8 Structural and Mounting Requirements on page 58](#) of this manual for further information.

2.5 Upgrade Installations

Upgrade installations occur after the installation of another system. A change in the customer's needs requires the installation of additional equipment at the same site. For example, adding a PET system to an existing CT system.

To proceed with an upgrade installation, the customer's room size must be large enough to accommodate the new product without violating the regulatory and service requirements of the new product. When planning for an upgrade installation, siting requirements of the new equipment may exceed those of your existing system. Requirements needing additional consideration include:

- Floor thickness
- Room shielding
- Additional electrical capacity
- Increased cooling capacity
- Scan room shielding requirements

The final site design must include a room layout showing the equipment room with the recommended room size dimensions. All upgrade installations must meet all service and regulatory requirements detailed in the manual.

2.6 Quick Installations

Quick Installations involve sites requiring minimum room improvements. These installations typically consist of a weekend de-installation and room preparation completion, with a next business day delivery and installation.

Requirements

A site must meet a number of requirements to qualify for a Quick Installation, including:

- Existing electrical disconnect device, wire size, and grounds must meet all requirements referenced in [3.2.2 Electrical on page 25](#)
- Existing structural specifications met, including floor thickness, and all requirements referenced in [3.2.3 Structural on page 25](#)
- Existing HVAC capacity and regulation must meet all requirements referenced in [3.2.5 Environmental on page 28](#)
- Existing CT suite must meet all regulatory and minimum size requirements referenced in [3.2.7 Clearances on page 29](#)
- Existing facility must accommodate delivery and meet all delivery requirements referenced in [3.2.10 Delivery on page 29](#)
- Existing facility must meet all scan room shielding requirements referenced in [3.2.4 Radiation Protection on page 28](#)

Consult your Project Manager of Installation (PMI) for information about any additional requirements.

Restrictions

The following restrictions govern Quick Installations: check with your PMI regarding floor anchor re-use.

- Quick Installations require a new room print that accurately reflects the rooms targeted for upgrade.
- You **CANNOT** re-use existing floor anchors for a new CT system.
- New floor anchors must be a minimum of 102 mm (4 in) from any existing floor penetrations.
- Rooms not meeting the minimum requirements for the final product must undergo an upgrade/enlargement prior to the installation.

2.7 Two-Step (Temporary) Installations

The two-step installation is a temporary installation of one system in a site, with the intention of upgrading the site to another system in a near future date. The following restrictions apply to two-step installations:

- Must comply with ALL siting requirements necessary for the upgraded or final system. This includes the recommended room size and all electrical, structural, and HVAC requirements.
- All requirements referenced in [3 System Siting Requirements on page 24](#) apply to these types of installations.
- The customer is responsible for verifying compliance with all requirements.
- Rooms not meeting minimum requirements for the final product must undergo sufficient upgrading/enlargement.

NOTE

Temporary installations include all systems installed at a site for a period ranging from two weeks to six months.

3 System Siting Requirements

3.1 System Siting Requirements

The requirements listed in this manual apply to all fixed-site customer installations, including installation within re-locatable buildings. The following requirements represent the **MINIMUM** that a site must meet before beginning **ANY** new or replacement system installation. All parties should review these requirements to ensure that the site:

- Meets all Service requirements
- Meets all Regulatory requirements
- Meets all minimum structural, flooring, and vibration requirements
- Meets minimum HVAC requirements
- Meets minimum Electrical requirements
- Meets all network requirements
- Meets all radiation protection requirements
- Meets all operational clearances
- Includes all finished doors, floors, windows, ceilings, walls, and all plumbing and cabinets are installed ([3.2.3.3 Finished Floor Requirements on page 26](#) and [3.2.3.4 Finished Walls Requirements on page 28](#) may apply).
- Does not have ANY continuing construction in the scan room OR neighboring suite areas.
- Conforms to the final GE site print, which must be kept ON-SITE and must show all items intended for the finished room.

NOTE

Each site should receive a Quick Start Kit from the PMI. Use the Pre-Installation Checklist in this manual to confirm that the site meets all of the requirements listed above. GE recommends completing all work to meet these requirements PRIOR to starting installation.

3.2 Customer System Siting Requirements

This section provides a breakdown of the customer tasks crucial for ensuring proper site preparation, regardless of whether planning for a replacement system at an existing site, or designing a new scan room for a first time.

Installation cannot proceed until verification of site-readiness occurs. A site is ready **ONLY** when it meets ALL delivery, regulatory, system, network, radiation protection, and operational requirements, as well as, requirements for any options. The purchaser is responsible for completing all work necessary to install the system, and includes:

- Completion of all items in [3.2.3 Structural on page 25](#) (recommended before installation begins.)
- PMI verification that ALL items on the Pre-Installation Checklist are completed.
- Review and preparation of all site-ready items.

To ensure timely delivery and installation, GE recommends that the customer complete all necessary work and schedule a site-ready visit prior to the delivery date. To confirm that the site meets all requirements, you may need to employ these and other contractors:

- Structural Engineer and/or Architect
- HVAC Contractor
- Electrical Contractor
- Qualified Radiological Health Physicist
- Cleaning Services.

NOTICE

An improperly prepared site—one that is in a state of construction—can result in a delayed installation date and/or damage to the system.

3.2.1 Regulatory Requirements

Verify that the site conforms to all of the following:

- The room must meet all regulatory clearance requirements.
- The room must meet all minimum size requirements.
- The site print is on-site, reflects actual room size and layout, and has received final approval.
- No grounded walls are found in regulatory clearance areas.
- The room meets all local codes.

3.2.2 Electrical

- Install the correct size junction boxes with covers at locations shown in the installation plan.
- Install appropriate conduits and duct work for system cables. If the suite houses additional components, determine the necessary considerations and complete the connections.
- Install a power supply of correct voltage output and adequate kVA rating.
- Install local disconnects, including proper over-current protection. This includes the A1/MDP main disconnect with Lock-out and Tag-out (LOTO) installation.

3.2.3 Structural

- Install “steelwork” or other suitable support work for mounting equipment from walls or ceilings.
- Review structural requirements including:
 - floor vibration
 - floor levelness
 - floor thickness
 - any seismic considerations, if applicable.
- Complete all suite and room renovations and modifications prior to delivery.

3.2.3.1 Dust and Air Quality

Ensure that the scan suite area is free of all dust, and not subject to ANY ongoing construction, including the installation of cabinets, hanging doors, and ceiling tiles.

**CAUTION**

POTENTIAL EARLY SYSTEM FAILURE.

Fine dust can deposit on the internal electronic components in Gantry, DAS, Tube, Table, PDU, and Operator Console.

It results in potential damage to the electronic components and lead to an early system failure.

Before installing scanner systems, ensure that the scan suite area is free of all dust and not subject to any ongoing construction.

TYPES OF DUST TO AVOID Ensure that NO construction occurs in or immediately around the scan suite area that results in:

- concrete dust
- drywall dust
- ceiling tile dust
- wood sawdust or shavings
- dust tracked into the CT suite from adjoining rooms

Failure to take appropriate precautions to protect the system against these types of dust may result in DAMAGE to the system and early SYSTEM FAILURE.

3.2.3.2 Environmental Influences

CT systems are designed with commercial components that are sensitive to air contaminants like sulfide, chloride and nitrates. It is the responsibility of the purchaser to ensure that the levels of these contaminates are low (Class1). See IEC60654-4 for air quality guidelines.

3.2.3.3 Finished Floor Requirements

**NOTE**

If a customer does not have concrete floor for the system installation, then the required anchoring must be approved by customer's structural engineer. It is customer's responsibility to finish the flooring.

Installation requires a finish floor in the scan and control rooms. The floor surface in the scan room directly under the gantry and table must be level. The scan room must be level by 6 mm (1/4 in) over the table and gantry area to be acceptable. Shims should not be used to compensate for a floor that does not meet this requirement. Eight or more floor covering openings that are 102 mm (4 in) in diameter are made to ensure the table and gantry rest on a solid surface. These floor penetrations can be sealed if required. These requirements apply to all installation types.

Finished Floor Exception 1

For sites replacing their scan room floor covering after the table and gantry are installed, the floor can be clean-finished with dust free concrete. The finish floor in the scan room requires no dust-producing operations when applying final floor covering.

Finished Floor Exception 2

Facilities under new construction that have a finished radiology area with a single controlled-access and dust abatement barrier, can have a finished concrete floor in the scan room. The finished concrete floor in the scan room requires no dust-producing operations when applying final floor covering.

Figure 3-1 Finished Floor Method 1 - Cable Routing from Side (Sample)

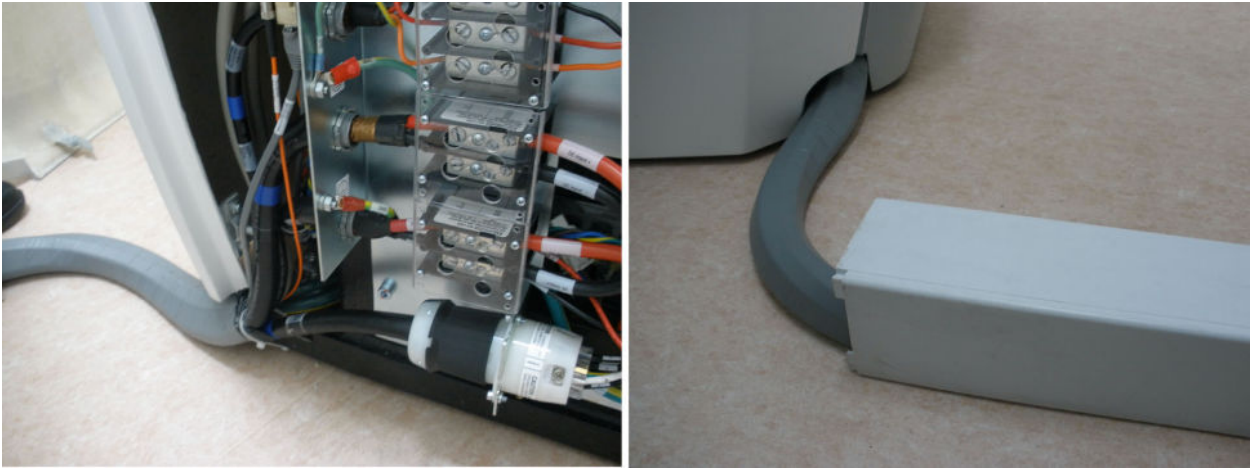
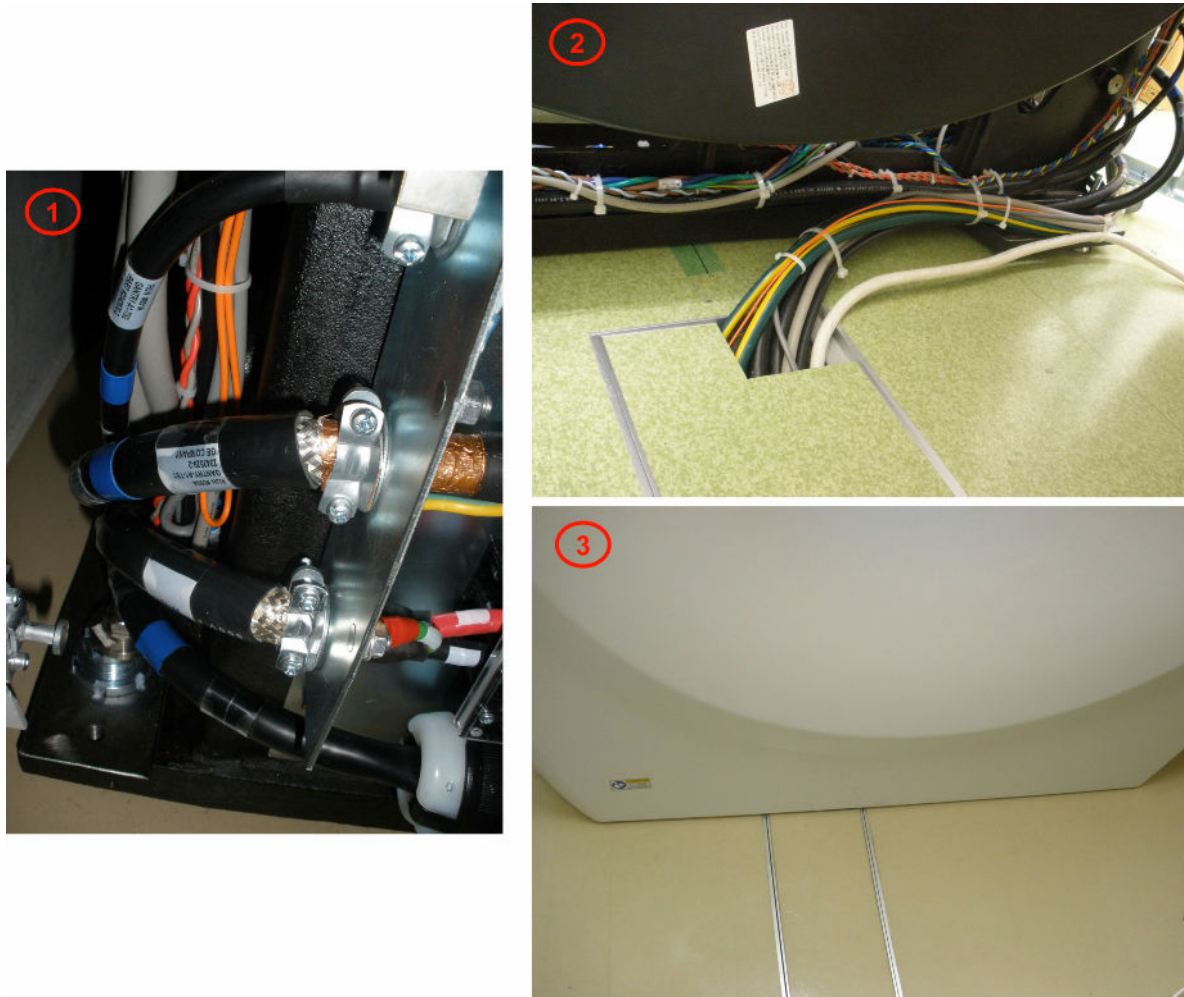

Figure 3-2 Finished Floor Method 2 - Cable Routing from Center (Sample)

3.2.3.4 Finished Walls Requirements

Finished walls inside the scan and control rooms must be painted at the time of installation. This requirement applies to all installation types. A finished walls exception is made for new construction and upgraded facilities. A primer coat of paint is acceptable for equipment installation. However, the final coat of paint must be applied using a brush of some type (roller, or bristle). The final coat of paint cannot be applied using a spray method.

3.2.4 Radiation Protection

A qualified radiological health physicist should verify that the scan room's radiation shielding provides adequate radiation protection for the planned system. Refer [10.1 Shielding Requirements on page 79](#) for more details.

3.2.5 Environmental

Review HVAC requirements, including system environmental controls and patient comfort needs. Make sure the site provides an HVAC system capable of maintaining the recommended temperature and humidity specifications at the time of installation.

3.2.6 Options

- Confirm that all customer installation options are reviewed and final locations determined.
- All GE supplied installation options are reviewed and final locations determined.
- The laser camera should be on site at the time of system installation.

3.2.7 Clearances

- Review operational clearances to verify whether daily use items fit (e.g. beds, carts).
- Consider clearances for emergency medical equipment.
- Ensure that all storage cabinets and sinks appear on the site print in their proper locations.
- Confirm that adequate space exists in the scan suite for delivery and installation of all replacement parts following installation of the system.

3.2.8 Network

Ensure that network communication is in place and active.

3.2.9 Chemical Contamination

Never install wet film processors in the same room as the scanner, as this may result in possible contamination of scanner components. Chemicals utilized by such processors can contribute to increased equipment failures and downtime, and decreased reliability.

When siting this equipment, consider the effects that contact with these chemicals and the resulting fumes might have on human subjects in proximity to them. In addition, film processor equipment installation must meet all manufacturer requirements (e.g. ventilation specifications) as well as all applicable local, state, and national codes.

3.2.10 Delivery

- Determine room dimensions and verify that doorways adequately accommodate the system.
- Verify the existence of an accessible dust-free non-construction zone route to the scan suite that accommodates delivery.
- Identify elevators, doorways and hallways that can accommodate delivery.
- Provide floor protection, if needed.
- Request rigging, if needed.

3.3 Site Readiness

3.3.1 Pre-Installation Tasks

The GE Project Manager of Installation (PMI) assists the purchaser in meeting all system siting requirements.

Pre-Installation Delivery Tasks

The PMI also performs the following pre-installation delivery tasks:

- Determines the delivery type: ground, dock or tilt bed truck.
- Determines if the delivery requires tilt dollies or riggers; orders dollies and lifting crates, as needed.
- Determines if the delivery requires the use of floor protection.
- Determines if the ground delivery requires the use of a tilt bed truck, and informs GE Transportation of the need for a tilt bed truck.

Site Review with Customer

A site-ready visit should occur prior to the delivery date. This visit verifies that the site meets all system siting requirements and confirms that installation can proceed. During the site-ready visit, a GE representative confirms that the site meets all of the required site-ready conditions including floor levelness, and delivery route readiness. Lifting options and construction site packaging must be ordered prior to delivery and cannot be added on-site.

4 Regulatory Requirements

4.1 Regulatory Clearances

4.1.1 Regulations

Review all codes in your area prior to your installation date. US customers should consider these codes:

- 29 CFR 1910 (OSHA)
- NFPA 70E (Standard for Electrical Safety in the Workplace)
- NFPA 101 (Life Safety Code)
- Americans with Disabilities Act

NOTICE

All systems installed within the United States and United States territories, and within United States government facilities, regardless of country, must comply with all United States Federal and local regulations. All systems installed outside the United States must comply with either the national, state, or local regulatory clearance requirements for the country in which the installation occurs, or US Federal regulations, whichever is greater.

4.1.2 Clearance Requirements

A map of clearance requirements necessary for proper operation and servicing of the system is provided in [Figure 4-1 U.S. Regulatory Clearance Requirements for Revolution ACTs on page 32](#).



NOTE

A similar map of detailed dimensional clearance measurements necessary for safe servicing of the system is provided in [Figure 5-1 Minimum Service Clearances on page 39](#)

NOTICE

The maps and dimensions shown in this manual depict the required clearances for proper equipment operation and service only. The customer/ purchaser is responsible for federal, state, and local codes regarding facility egress and related facility requirements.

NOTICE

The use of alternate layouts puts severe limitations on space for patient care and work flow. Customer approval of site drawings signifies customer agreement to these limitations.

Figure 4-1 U.S. Regulatory Clearance Requirements for Revolution ACTs

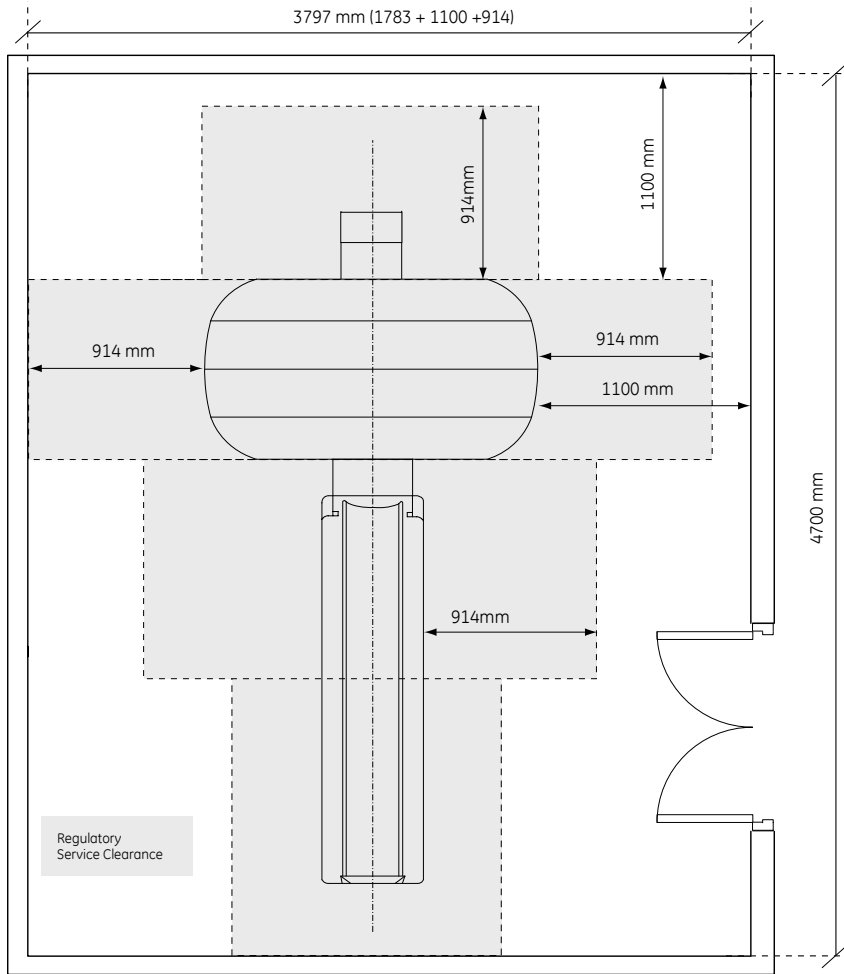

4.1.3 Minimum Regulatory Workspace Clearances by Major Subsystem

Note the following when referring to the tables below:

- These requirements apply to equipment operating at 600 V or less, where examination, adjustment, servicing, or maintenance is likely to be performed with live parts exposed.
- The customer **MUST** maintain the required regulatory clearance distances and may **NOT** use these area for storage. This applies during normal system operation as well as during service inspection and maintenance.
- Direction of Service Access refers to a direction perpendicular to the surface of the equipment serviced.

Table 4-1 CONSOLE – Minimum Workspace Clearances

Workspace Requirement	Minimum Clear Space	Additional Conditions
Direction of Service Access (front and rear of console)	Not applicable. (no exposed live part hazards.)	

Continues on the next page

Table 4-1 CONSOLE – Minimum Workspace Clearances (Table continued)

Workspace Requirement	Minimum Clear Space	Additional Conditions
Service Access Width (front and back of work-space)		Refers to the width of the working space in front of equipment. 762 mm (30 in) minimum or the equipment width, whichever is greater.
Head Clearance	1981 mm (78 in.)	Refers to the height of the work-space measured from the floor at the front edge of the equipment to the ceiling or any overhead obstructions. 1981 mm (78 in) or the height of the equipment, whichever is greater.

NOTE

Distances are measured to the finished covers.

Table 4-2 PDU – Minimum Workspace Clearances

Workspace Requirement	Minimum Clear Space	Additional Conditions
Direction of Service Access (Front of PDU)	914 mm (36 in.)	1219 mm (48 in) if exposed live parts of 151-600 Volts are present on both sides of the work-space with the operator between. 1067 mm (42 in) if the opposite wall is grounded and exposed live parts of 151-600 Volts are present.
Service Access Width (Front of Work-space)	762 mm (30 in.)	Refers to the width of the working space in front of equipment. 762 mm (30 in) minimum or the equipment width, whichever is greater.
Head Clearance	1981 mm (78 in.)	Refers to the height of the work-space measured from the floor at the front edge of the equipment to the ceiling or any overhead obstructions. 1981 mm (78 in) or the height of the equipment, whichever is greater.

**NOTE**

For the Gantry and Table, distances are measured from the finished covers.

Table 4-3 GANTRY – Minimum Workspace Clearances

Workspace Requirement	Minimum Clear Space	Additional Conditions
Direction of Service Access (All Sides)	914 mm (36 in.)	1219 mm (48 in), if exposed live parts of 151-600 V are present on both sides of the work-space with the operator between. 1067 mm (42 in), if the opposite wall is grounded and exposed live parts of 151-600 V are present.
Service Access Width (Left-Right of Workspace)	762 mm (30 in.)	Refers to the width of the working space in front of equipment. 762 mm (30 in) minimum or the equipment width, whichever is greater.

Continues on the next page

Table 4-3 GANTRY – Minimum Workspace Clearances (Table continued)

Workspace Requirement	Minimum Clear Space	Additional Conditions
Head Clearance	1981 mm (78 in.)	Refers to the height of the work-space measured from the floor at the front edge of the equipment to the ceiling or any overhead obstructions. 1981 mm (78 in) of the height of the equipment, whichever is greater.

Table 4-4 TABLE – Minimum Workspace Clearances

Workspace Requirement	Minimum Clear Space	Additional Conditions
Direction of Service Access (Table Head)	not applicable	
Direction of Service Access (Table Sides)	914 mm (36 in.)	Can be reduced to 711 mm (28 in) provided the local team obtains written and signed approval from the local AHJ (Authority Having Jurisdiction). GE must have the signed document on file.
Direction of Service Access (Table Foot)	711 mm (28 in.)	457 mm (18 in.) minimum for Front Gantry Cover removal, only if an unobstructed egress space of 711 mm (28 in.) exists around the equipment for room exit, and no trip hazards exist along the path of egress.
Service Access Width (Left-Right of Workspace)	762 mm (30 in.)	Refers to the width of working space in front of equipment. 762 mm (30 in) minimum or the equipment width, whichever is greater.
Head Clearance	1981 mm (78 in.)	Refers to the height of the work-space measured from the floor at the front edge of the equipment to the ceiling or any overhead obstructions. 1981 mm (78 in) minimum or the equipment height, whichever is greater.

Table 4-5 UPS – Minimum Workspace Clearances

Workspace Requirement	Minimum Clear Space	Additional Conditions
Direction of Service Access (Front of UPS)	914 mm (36 in.)	There are no exposed live part hazards with the cover in place. This component is typically serviced from the front with access to the rear. * If exposed live parts of 151 - 600 volts are present, 1219 mm (48 in.) is required on both sides of the workspace with the operator between. * If the opposite wall is grounded and exposed live parts of 151 - 600 volts are present, 1067 mm (42 in.) is required.
Service Access Width (Left-Right of Workspace)	762 mm (30 in.)	Refers to the width of working space in front of equipment. 762 mm (30 in.) minimum or the equipment width, whichever is greater.
Head Clearance	1981 mm (78 in.)	Refers to the height of the work-space measured from the floor at the front edge of the equipment to the ceiling or any overhead obstructions. 1981 mm (78 in) minimum or the equipment height, whichever is greater.

Table 4-6 A1/MDP – Minimum Workspace Clearances

Workspace Requirement	Minimum Clear Space	Additional Conditions
Direction of Service Access (Front of A1/MDP Disconnect)	914 mm (36 in.)	There are no exposed live part hazards with the cover in place. This component is typically serviced from the front with access to the rear. * If exposed live parts of 151 - 600 volts are present, 1219 mm (48 in.) is required on both sides of the workspace with the operator between. * If the opposite wall is grounded and exposed live parts of 151 - 600 volts are present, 1067 mm (42 in.) is required.
Service Access Width (Left-Right of Workspace)	762 mm (30 in.)	Refers to the width of working space in front of equipment. 762 mm (30 in.) minimum or the equipment width, whichever is greater.
Head Clearance	1981 mm (78 in.)	Refers to the height of the workspace measured from the floor at the front edge of the equipment to the ceiling or any overhead obstructions. 1981 mm (78 in) minimum or the equipment height, whichever is greater.

4.1.4 How to Measure

Figure below offers guidance on the proper way to measure to check minimum regulatory clearances.

Figure 4-2 Measuring Minimum Regulatory Clearances

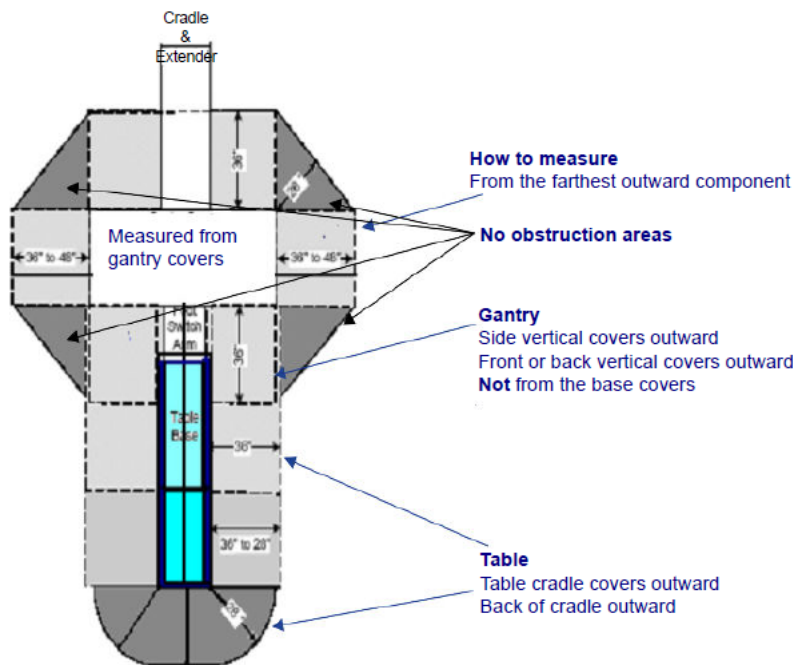

⚠ CAUTION**REGULATORY CAUTION**

All system installations, relocations, and moves, require site prints. The CT room layout shall match the layout shown on your site print and meet all regulatory requirements described in the installation manual. Additional room components, such as cabinets and sinks, reduce room size. Consequently, equipment not shown on the site print may void the caution statement, making the room NON-COMPLIANT. Actual site measurements obtained by the mechanical installer before installation determines room size and compliance.

⚠ CAUTION**OPERATIONAL CAUTION**

In the minimum room layout (356 mm to 686 mm [14 in. to 27 in.]) the customer should consider workflow, customer access for patient care, and critical-care operations space requirements. Additionally, this layout may offer only limited equipment access on the gantry left side when loading patients or when positioning patient equipment in the room between the gantry and the wall.

4.1.5 NEC Conduit and Duct Fill Rate

Full operation, service, and safety of the system requires the maintenance of sufficient regulatory and service clearances around equipment.

Cable length is an important consideration in room layout. The system ships with standard (short) length cables, with a set of longer cables available as an option. Refer to the electrical page of your GE site print for the specific requirements of your site. The following rules govern cable usage for the system:

- When possible, use the rear cable cover assembly to let cables enter the gantry from the rear.
- Do not cut or otherwise shorten long cables.
- Do not store excess cable length behind the operator console, gantry, or PDU.
- Store excess cable in wall or floor ducts, if desired, provided that sufficient space exists. Refer to NEC code to determine cable fill rates for conduits and ducts.
- All installed systems shall comply with NFPA 70-E Electrical Regulations governing conduit or duct fill.

4.2 Regulatory Terms and Definitions

CLEARANCES

Clearances are the clear space or distance between or around objects and equipment, governed by all applicable safety, service and regulatory requirements and representing the lowest margin of freedom permissible for equipment siting.

DIMENSIONS

The length, width, depth and height of equipment.

EGRESS

An egress is the single path of exit from within any room. It is the customer's responsibility to provide a means of egress.

PRE-INSTALLATION ESCALATION

Pre-installation escalation is the process used to consult CT Engineering, the Design Center, or Environmental Health and Safety (EHS) to resolve preinstallation issues related to siting concerns and requirements.

GROUNDING WALL

A grounded wall is any wall with electrical conductivity to earth. Conductive materials generally found in walls include masonry, concrete, and tile. Treat as grounded additional elements commonly found in walls, including but limited to:

- Medical gas ports and plates
- Metal doors and window frames
- Water sources and metallic sink structures
- Metallic wall mounted cabinets
- A1 main disconnect panel
- Equipment Emergency Off panels
- Industrial equipment (such as air conditioners and vents)
- Expansion joints
- Surface raceway
- Exposed wall conduits
- Floor outlet boxes
- Floor HVAC boxes
- Floor medical gas

Common wall components **NOT** constituting grounded elements include:

- Standard wall outlet
- Light switches
- Telephones
- Communication wall jacks
- Ceiling tile grids

HEAD CLEARANCE

Head clearance represents the height dimension of the workspace, measured from the floor at the front edge of the equipment to the ceiling or any overhead obstructions. It requires a minimum of 1981 mm (78 in) of the height of the equipment, whichever is greater.

MINIMUM

Minimum indicates the lowest limit permitted by law or other authority.

SERVICE ACCESS WIDTH

Service access width refers to the width of the working space in front of the equipment, and requires a minimum of 762 mm (30 in) or the width of the equipment, whichever is greater.

WORKSPACE

The workspace represents a three dimensional box of space required for safe inspection or service of energized equipment. It consists of depth, width, and height, with the depth dimension measured perpendicular to the direction of access. US regulation requires a minimum depth of 914 mm (36 in). Additional conditions can increase the minimum requirement. For example, FCT defines workspace as the envelope of the component superstructure, measured for the PDU with the front panel removed, and measured for the gantry and table with the extended covers removed.

5 Service Clearance Requirements

5.1 Service Clearance Requirements

- Sufficient space to remove the covers [Figure 5-1 Minimum Service Clearances on page 39](#).
- One service engineer shall be able to accomplish all service component replacement tasks without needing special tools or equipment.
- ALL room layouts to provide service space and access around the table to the gantry right side. This is needed for replacement procedures that require components that ship in large boxes, such as the tube, detector, and HV tank.

Figure 5-1 Minimum Service Clearances

		Minimum Clearances	
	Item	Dimension	
	1	3620 mm (142.5 in.)	(travel distance of table, without cradle extender)
	2	1060 mm (41.7 in.)	(scan center to wall, without extender)
		1320 mm (51.9 in.)	(scan center to wall, with extender)
	3	270 mm (11 in.)	
	4	420 mm (16.6 in.)	
	5	1783 mm (70.2 in.)	
	6	165 mm (6.5 in.)	Minimum separation distance between gantry and rear cover
	7	2283 mm (89.9 in.)	
	8	525 mm (21 in.)	
	8a	1115 mm (43.9 in.)	
9	140 mm (5.5 in.)		
10	2475 mm (97.5 in.)		
11	200 mm (7.9 in.)		
CT Components			
Item	Description		
A	Gantry with covers installed		
B	Table cradle footprint, coverage as extended in both directions		
C	Gantry rear cover (thickness 200mm)		

5.2 Service Clearances

NOTE

When calculating service clearances, refer to [Figure 5-1 Minimum Service Clearances on page 39](#) for all service clearance needs.

5.2.1 Gantry Service Clearance for Tube and Detector Replacement

Specifications for Boom Assembly clearance arc are defined in [Figure 5-2 Boom Assembly Clearance on page 40](#). The boom assembly is used during tube and detector replacement. The minimum ceiling height within the clearance radius is 2286 mm (90 in).

Figure 5-2 Boom Assembly Clearance

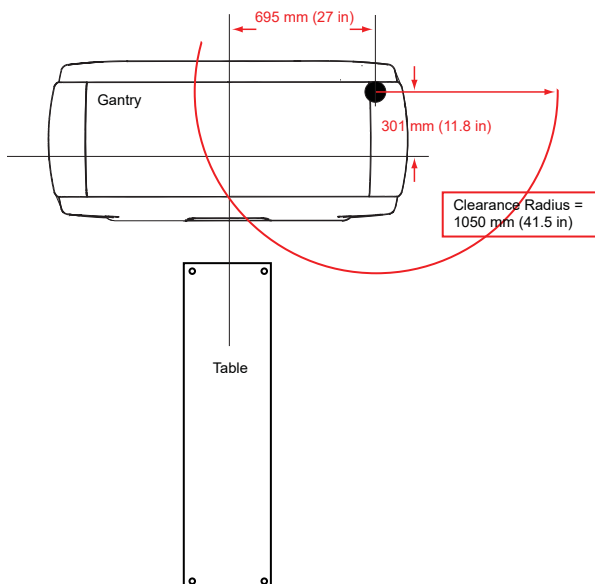

5.2.2 Cover Removal

- Gantry front cover removal requires the use of the Cover Dollies, but if at minimum room width clearance space of 2475 mm (97.5 in.), two FEs should work to remove the front cover manually. The dollies allow the service engineer to separate the cover from the gantry, step by step raise the Gantry Front Cover to the proper position with the cover dollies to move out it from gap between the Gantry and Table. After removal, the service engineer must then move the gantry front cover to a position that satisfies the minimum regulatory clearances.

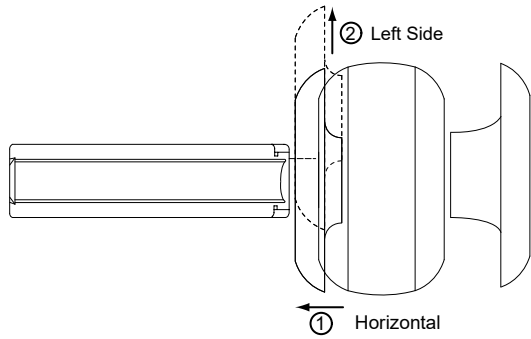
Figure 5-3 Gantry Front Cover Removal

- The gantry rear cover, with service dollies installed, requires a clearance width of 1790 mm (70.5 in.) and a depth of 914 mm (36 in.) for removal. Sufficient space to allow the service engineer to move the cover either straight back or to one side of the table to satisfy the minimum service clearances. The rear cover with dollies cannot extend past the allowable clearance space within the room (see [Figure 5-1 Minimum Service Clearances on page 39](#)). If the system is not sited straight (it is positioned diagonally), full service space is still required. The PMI and customer should discuss this consideration and make the necessary provisions.
- The scan room must offer sufficient space to allow adequate egress during service operations that require both front and rear cover removal. If the customer and PMI have any concern that site will not provide adequate space for egress under these conditions, they should discuss these requirements and make the necessary provisions to accommodate this event.
- A single service engineer can safely perform servicing of the table. Ensure sufficient clear space to maintain egress clearances with the table covers or cradle removed.
- A single service engineer can safely perform servicing of the system. Ensure sufficient clear space to maintain egress clearances with covers or cradle removed.
- MX135CT (Venus) and MX 135CT R(Venus R) tube change box dimensions are 890 x 700 x 560 mm (35 x 27.6 x 22 in), with the handles extended. The box rolls like a wheelbarrow and must have access to the right side of the gantry. The MX135CTX (LMB) tube change box dimensions are less than 925 x 695 x 830 mm (36.4 x 27.4 x 32.7 in) (including pallet dimension). The box must have access to the right side of the gantry. It is the PMI's responsibility to demonstrate that the tube change box can be positioned in the tube change area next to the gantry and that the front and rear covers can be removed.

5.2.3 Power Distribution Unit (PDU)

When positioning the Power Distribution Unit (PDU), consider regulatory compliance, as defined in [4.1 Regulatory Clearances on page 31](#). See [Table 4-2 PDU – Minimum Workspace Clearances on page 33](#) in that section.

5.2.4 Console

As some service activities require access to the rear of the console, be sure to maintain sufficient space for moving the console to allow rear service access.

See [Figure 6-5 Typical Control Room Layout without PDU on page 49](#) for a typical control room layout.

5.2.5 System Accessory

GE provides a Shipping Collector : 5620440

6 Room Sizes

6.1 Room Dimensions

Table 6-1 Scan Room Size Dimensions

System Configuration	Suggested / Typical Room Size ^{*1}	Minimum Room Size ^{*2}
Revolution ACTs with Aakash Table	4700mm * 3183mm (15.4 ft * 10.5 ft) (No PDU & PDA in Scan Room)	4160 mm * 2475 mm(13.6 ft * 8.1 ft) ^{*3} (No PDU & PDA in Scan Room)
	4700mm * 3633mm (15.4 ft * 11.9 ft) (PDU & PDA in Scan Room)	
¹ All service/regulatory requirements apply in accordance with country specific regulations. (e.g., In India, follow AERB Regulation. For other countries follow local regulation.) ² All service/regulatory requirements can not apply tentatively, with the addition of no energized left-side service. Minimum room size includes Axial Head Holder and Extender. ³ The minimum room size can satisfy no less than 1200mm scan range (with axial head holder).		

6.1.1 Suggested Room Size

The suggested room configuration offers the most flexibility for future upgrades. It provides both ample workspace and space to add mill-work and still meet all regulatory requirements. When local regulations require a sink in the scan room, this room size also provides sufficient space for a sink. This room size accommodates the needs of larger hospitals and medical teaching facilities, where patients may require transportation to the scan area in beds, gurneys, and larger wheelchairs and where they may require the assistance of larger medical care teams. Likewise, this room offers adequate access for crash carts and other emergency medical equipment on both sides of the table. Future upgrades may need additional equipment. You may want to consider an equipment room. The suggested size supports all service activities, including tube change, and accommodates all future two-step installations.

6.1.2 Typical Room Size

The typical room configuration represents what is most commonly found at installation sites. It offers adequate workspace and may provide adequate space for a sink, but allows only LIMITED space to add mill-work and still meet all regulatory requirements. The size of this room accommodates the needs of larger clinics and medium-sized hospitals, where patients may require transportation into the scan area using gurneys and wheelchairs, and where they may require the assistance of small medical care teams. It provides access for crash carts and other emergency medical equipment on only one side of the table.

The typical room size supports all service activities, including tube change, and may offer compatibility with SOME future upgrades and two-step installations.

6.1.3 Minimum Room Size

The minimum room configuration represents the smallest functionally acceptable space for this product and represents the type of room often found at doctor's offices and smaller clinics and outpatient facilities. Due to its limited size, and to functional and regulatory requirements, this room usually provides only LIMITED workspace, and leaves to NO space to add in-room millwork and sinks and still meet the necessary regulatory and service requirements. This room can accommodate the transportation of patients into the scan area using wheelchairs, and provides access for crash carts and other emergency medical equipment on only one side of the table.

Sites considering a minimum room size may not have been designed with the structural requirements necessary to support the system and consequently may require upgrading prior to installation.

Customers considering a minimum room size should discuss their workspace requirements and future upgrade plans with their PMI, as the size and layout of these rooms often eliminates them from any future upgrade considerations and offers NO compatibility with future two-step installations.

If using the square meters (square footage) to determine regulatory compliance, please note that the front and rear cover clearances are wider than the regulatory clearance along the table length, and that the cover park position is behind the table in the home position.

NOTE

Sites must provide sufficient space to allow the removal of the rear cover, which is on wheels, from behind the gantry during service operations.

CAUTION



OPERATIONAL CAUTION

In a minimum room layout (270/420mm on left/right Gantry side) the customer should consider workflow, customer access for patient care, and critical-care operations space requirements. Additionally, this room provides only limited equipment access on the gantry left side when loading patients or when positioning patient equipment in the room between the gantry and the wall.

6.2 Suggested and Typical Room Layouts without PDA



NOTE

[Figure 6-1 Suggested / Typical Room Size for Revolution ACTs without PDA on page 45](#) shows the recommended and typical room layouts. You need to know the locations for medical gas, surface duct work, or other items that make a grounded wall.

Your room layout may meet the recommended or typical room requirements but appear different than [Figure 6-1 Suggested / Typical Room Size for Revolution ACTs without PDA on page 45](#). Your salesperson can provide a detailed room layout for your site.

NOTICE

For U.S. regulatory compliance, refer to [Figure 4-1 U.S. Regulatory Clearance Requirements for Revolution ACTs on page 32](#) for service clearance requirement of scan room layout.

Figure 6-1 Suggested / Typical Room Size for Revolution ACTs without PDA

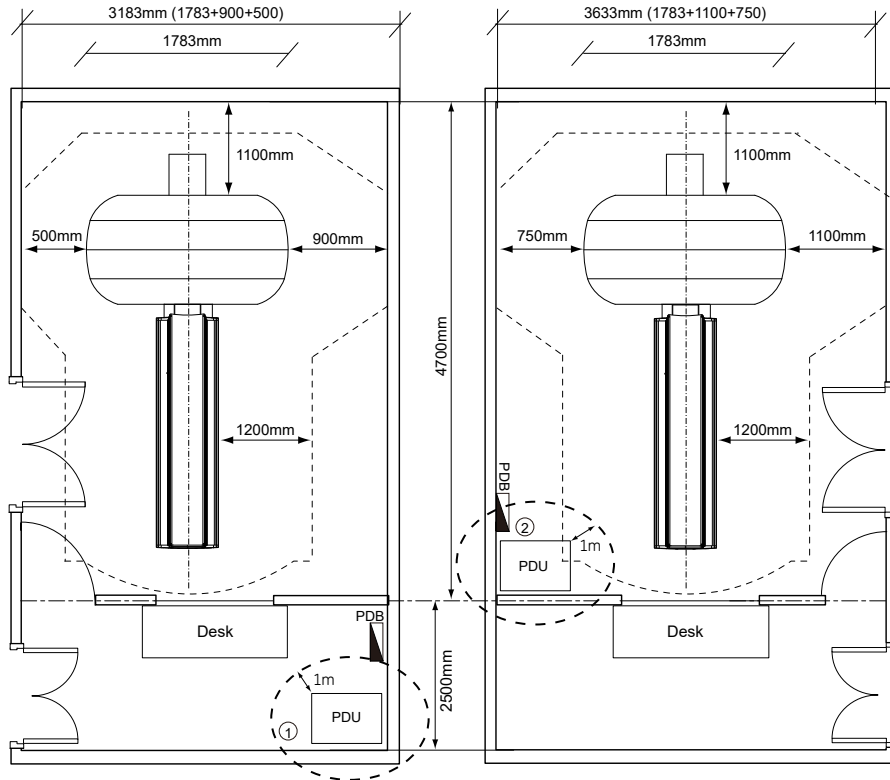

NOTE 1: One side of the Gantry is no less than 900mm for the Gantry Front/Rear Cover removal.
 NOTE 2: The distance is no less than 1100mm between the Gantry Rear Cover and wall used to service SlipRing.
 NOTE 3: ① and ② are two kinds of PDU positions, ② is recommended PDU position.
 NOTE 4: The PDU has EMI range.

6.3 Suggested and Typical Room Layouts with PDA



NOTE

Figure 6-2 Suggested / Typical Room Size for Revolution ACTs with PDA on page 46 shows the recommended and typical room layouts. You need to know the locations for medical gas, surface duct work, or other items that make a grounded wall.

Your room layout may meet the recommended or typical room requirements but appear different than Figure 6-2 Suggested / Typical Room Size for Revolution ACTs with PDA on page 46. Your salesperson can provide a detailed room layout for your site.

NOTICE

For U.S. regulatory compliance, refer to Figure 4-1 U.S. Regulatory Clearance Requirements for Revolution ACTs on page 32 for service clearance requirement of scan room layout.

Figure 6-2 Suggested / Typical Room Size for Revolution ACTs with PDA

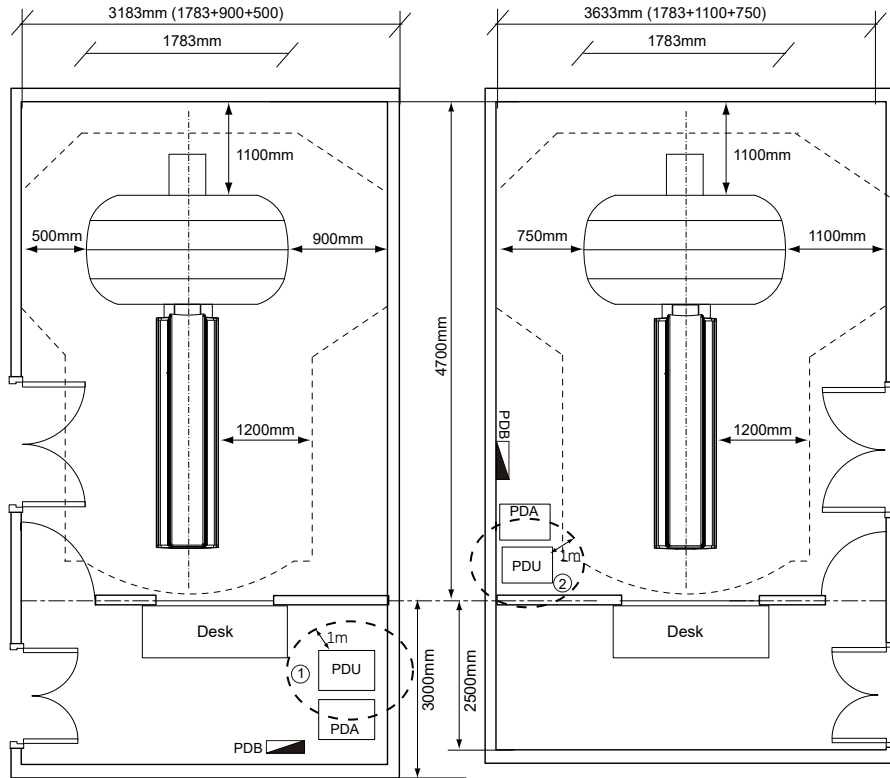

NOTE 1: One side of the Gantry is no less than 900mm for the Gantry Front/Rear Cover removal.
 NOTE 2: The distance is no less than 1100mm between the Gantry Rear Cover and wall used to service SlipRing.
 NOTE 3: ① and ② are two kinds of PDU positions, ② is recommended PDU position.
 NOTE 4: The PDU has EMI range.

6.4 Minimum Room Layouts without PDA Option

Room layouts provide less than 500 mm (20 in.), but greater than 270 mm (11 in.) of space on the gantry left side, measured from covers to left-side wall, compromising service, egress, and workspace on the gantry’s left side.

The maximum scannable range in minimum scan room with Axial Head Holder should be no less than 1200mm.



NOTE

- Leave at least 15.5 cm (6") between the PDU and back wall to allow cooling air to circulate, this minimum scan room size does not allow for the SVCT PDU or Surface mounted floor duct.
- GE’s desk may not fit into the minimum control room as shown figure below.

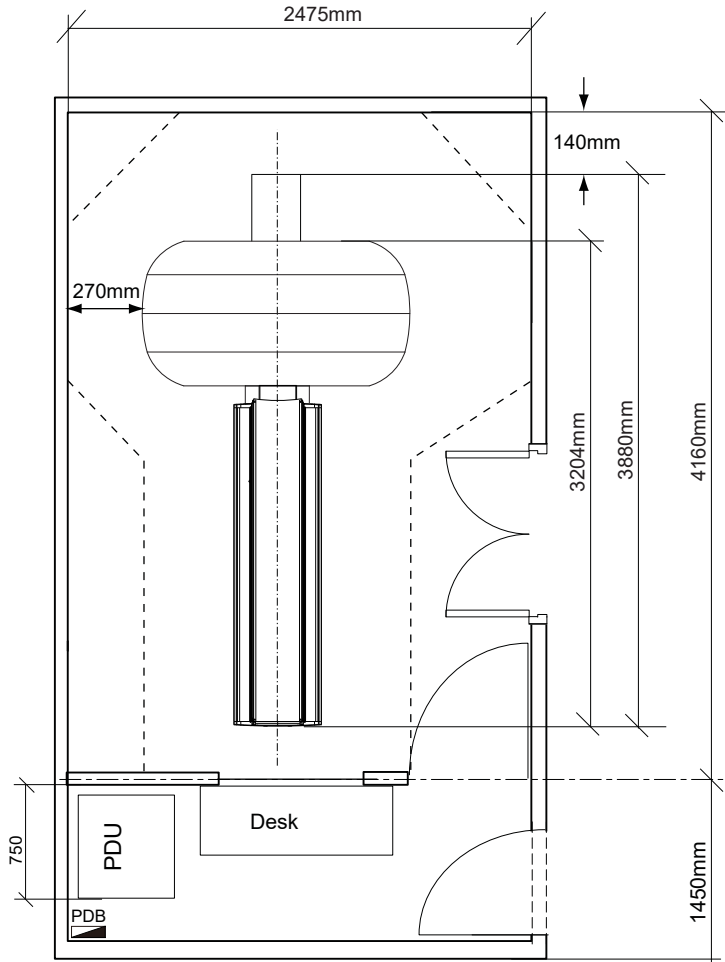
Figure 6-3 Minimum Room Size for Revolution ACTs with Axial Head Holder (without PDA Option)

6.5 Minimum Room Layouts with PDA Option

Room layouts provide less than 500 mm (20 in.), but greater than 270 mm (11 in.) of space on the gantry left side, measured from covers to left-side wall, compromising service, egress, and workspace on the gantry's left side.

The maximum scannable range in minimum scan room with Axial Head Holder should be no less than 1200mm.



NOTE

- Leave at least 15.5 cm (6") between the PDU/PDA and back wall to allow cooling air to circulate, this minimum scan room size does not allow for the SVCT PDU or Surface mounted floor duct.
- GE's desk may not fit into the minimum control room as shown figure below.

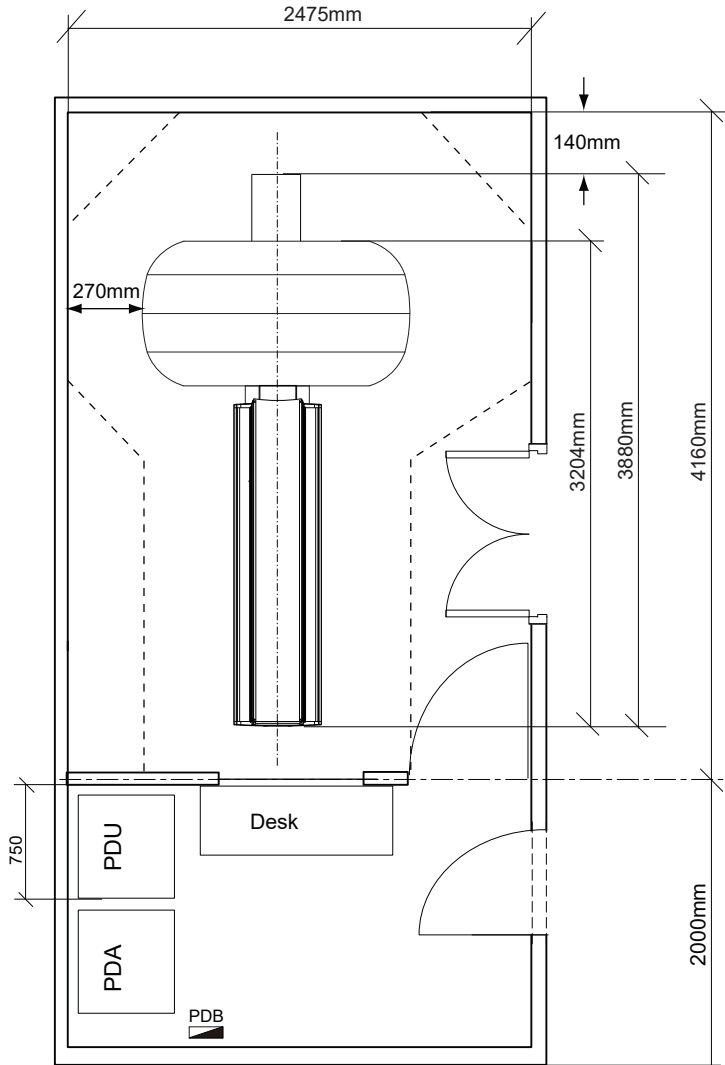
Figure 6-4 Minimum Room Size for Revolution ACTs with Axial Head Holder (with PDA Option)

6.6 Control Room Considerations

- The control room must provide an operating environment suitable for the console electronics and the operator's working comfort. See [9 Environmental Requirements on page 70](#).
- As the console requires adequate venting, maintain 96 mm (4 in.) of clear, unobstructed space on all sides of the console to allow the four fans located on the rear of the console to exhaust air to both the left and right.
- Provide a suitable work area within reach of the console for the placement of the injector control. Injector controls differ in dimensions depending on the brand selected.
- A PACS, workstation, image printer, or filming device may appear in the console control room area. These devices or other components, though having a direct link to the console via network or ethernet cable, shall NOT receive power from the console (if outlets exist on the console). If you are using additional devices or components, consider additional room power and network connections when reviewing the console workspace.

6.6.1 Typical Control Room Layout

6.6.1.1 Console Considerations

- The console must remain in the same configuration as shipped. Do not dismantle the console, or remove or rearrange its components.
- Cable lengths must remain as shipped (cables cannot be cut or extended to mount the monitor on the customer's counter).

Figure 6-5 Typical Control Room Layout without PDU

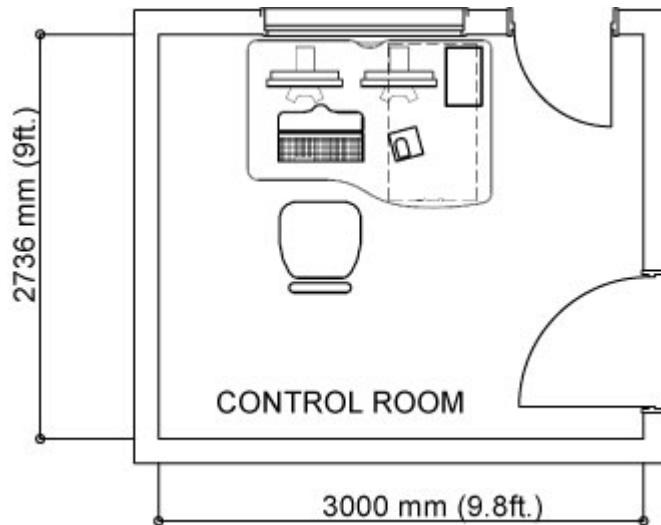

6.7 Patient Environment

NOTICE

When install the console in the scan room, do not place it within the patient environment.

The patient environment is defined as the following picture.

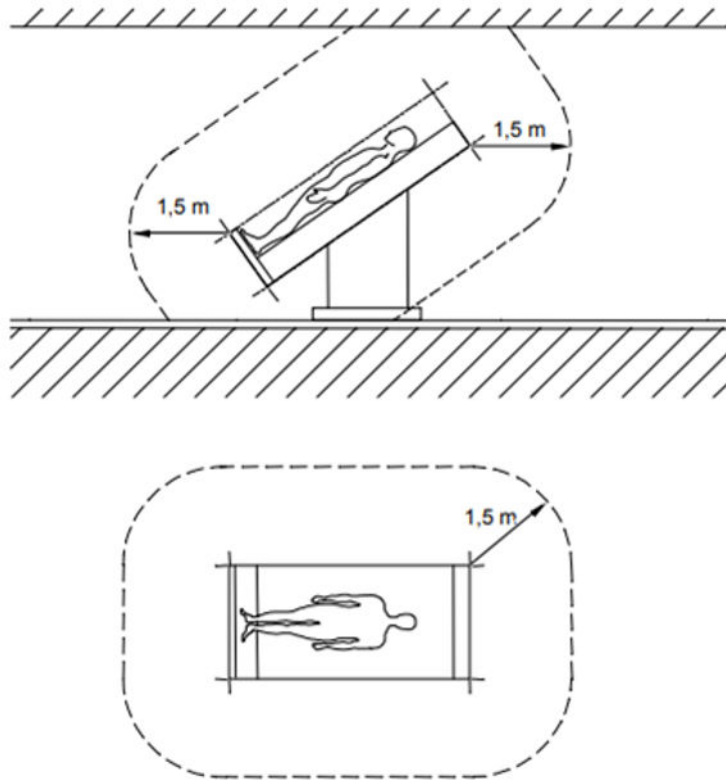

IEC 2431/05

Only Scanning Gantry, Patient Table components and the following options can be placed in this area.

- Extream Injector
- AVIMOS Camera

7 System Component Dimensions

7.1 Minimum Operating Clearances

The sections in this chapter provide the minimum dimension and operating clearance information for each category of components listed. Be sure that the site conforms to each of these specifications.

7.1.1 Ceiling Pedestal Mount Installation

The distance from the floor to the lowest point of the ceiling pedestal mount for the Injector or Monitor CANNOT measure LESS than 2134 mm (84 in.). Refer to the installation guides of those components for the length of the mounting post.

NOTICE

Failure to maintain a distance of at least 2134 mm (84 in.) from the floor to the lowest point of the Injector or Monitor ceiling pedestal mount may pose a safety hazard. For installations with a finished ceiling height that is less than suggested, consideration should be given to utilizing floor mounted components, or attaching the mounting plate in the overhead (for example, above dropped ceiling tiles).

7.1.2 System Operational Clearances

The clearances listed in [Table 7-1 Minimum Dimensions and Operational Clearances on page 51](#) govern system operation; be sure that the site maintains each of these clearances.

Table 7-1 Minimum Dimensions and Operational Clearances

System Operation	mm	inches
Ceiling Pedestal mount (optional)	2134 mm	84 in.
Lowest point to floor injector or monitor		
Finished ceiling to floor (suggested)	2743 mm	108 in.
Finished ceiling to floor (minimum)	2400 mm	94.5 in.
Table maximum extension head end without Axial Head Holder to Scan Center Line	970 mm	38.1 in.
Table maximum extension head end with Axial Head Holder to Scan Center Line	1270 mm	49.9 in.
Table extension head end with extender to obstruction (wall)	120 mm	4.7 in.
Table with cradle at home position to surface of Gantry front cover.	2283 mm	89.9 in.
Back of Console to wall	96 mm	4 in.
Back of PDU to wall	152 mm	6 in.
Back of PDA to wall	152 mm	6 in.

7.2 Component Dimensions

7.2.1 Gantry Dimensions

Figure 7-1 Gantry Dimensions with Covers

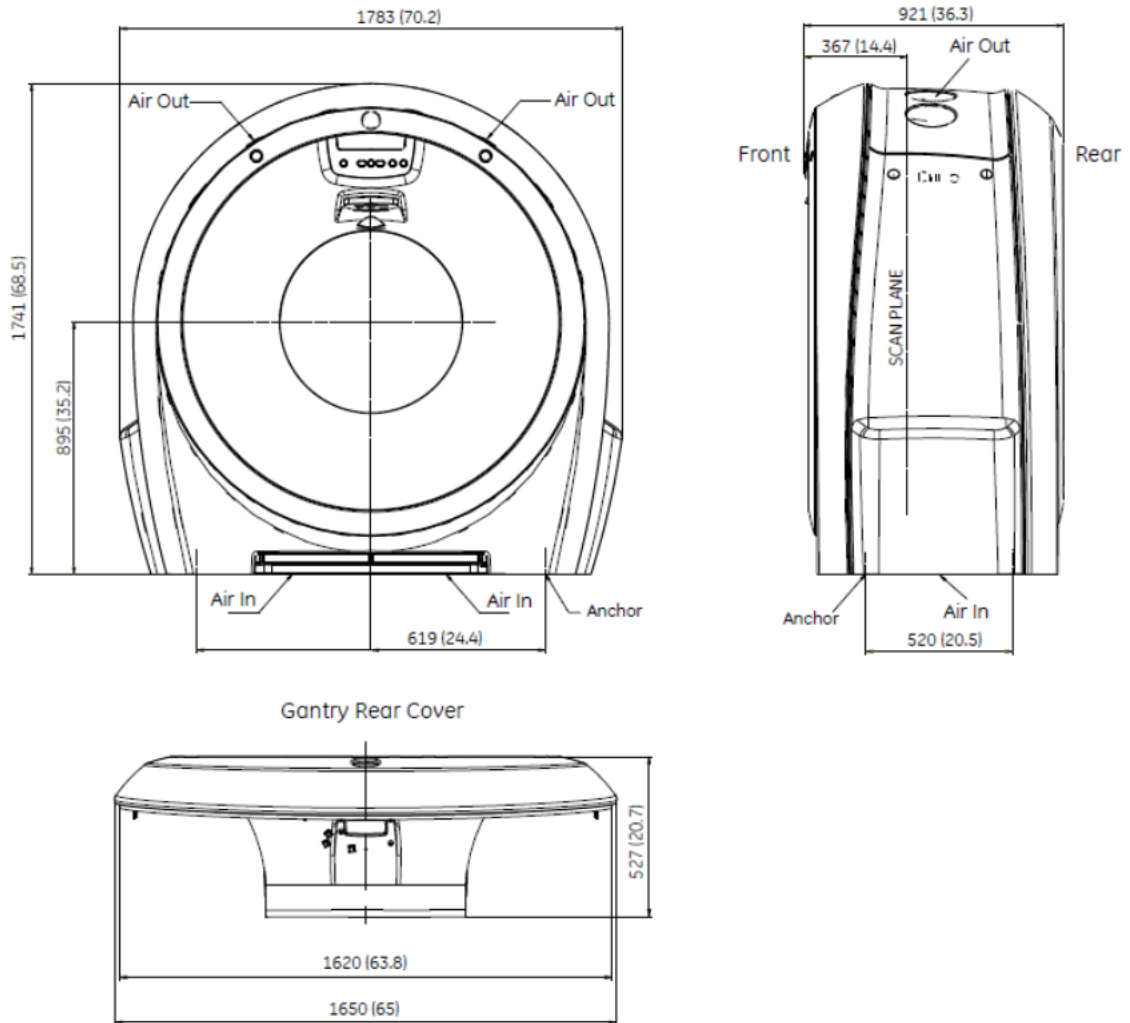

7.2.2 Table and Gantry Dimensions

Figure 7-2 Aakash Table and Gantry

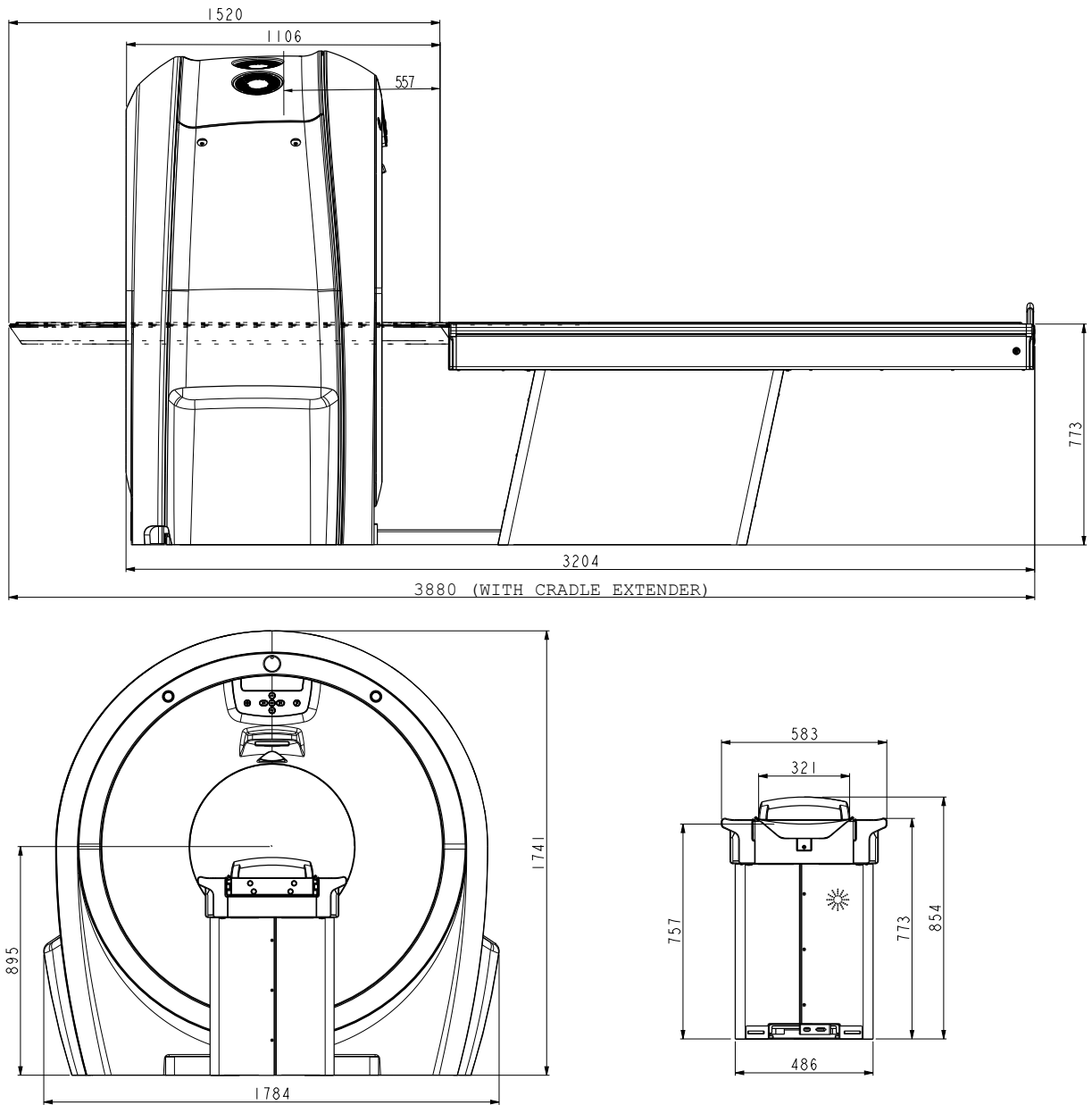

7.2.3 Power Distribution Unit Dimensions

PDU dimensions, air intake/exhaust, seismic bracket locations, and service areas appear below.

Figure 7-3 Power Distribution Unit

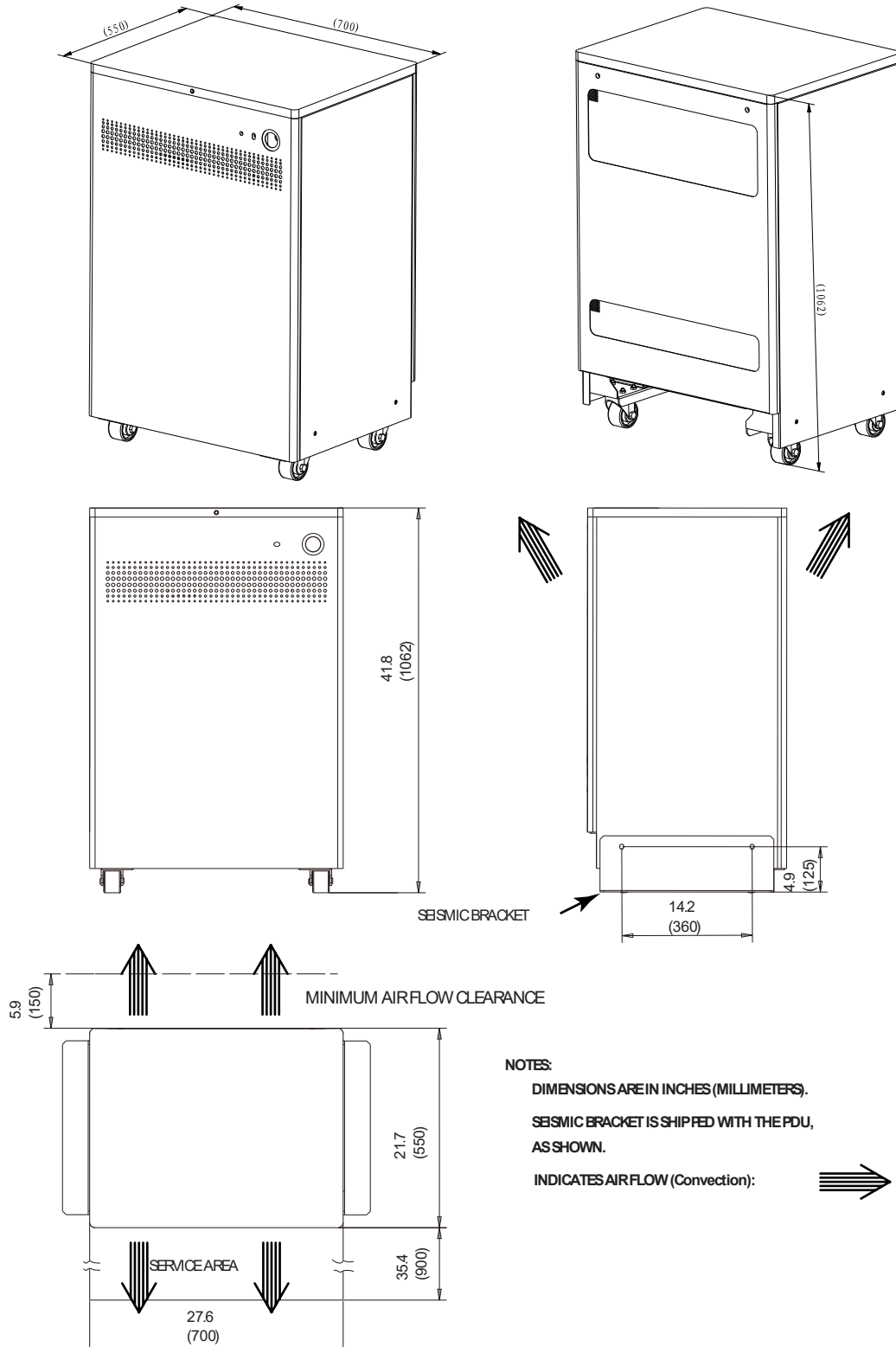

7.2.4 Power Distribution Adapter Dimensions

PDA dimensions, air intake/exhaust, seismic bracket locations, and service areas appear below.

Figure 7-4 Power Distribution Adapter Dimensions

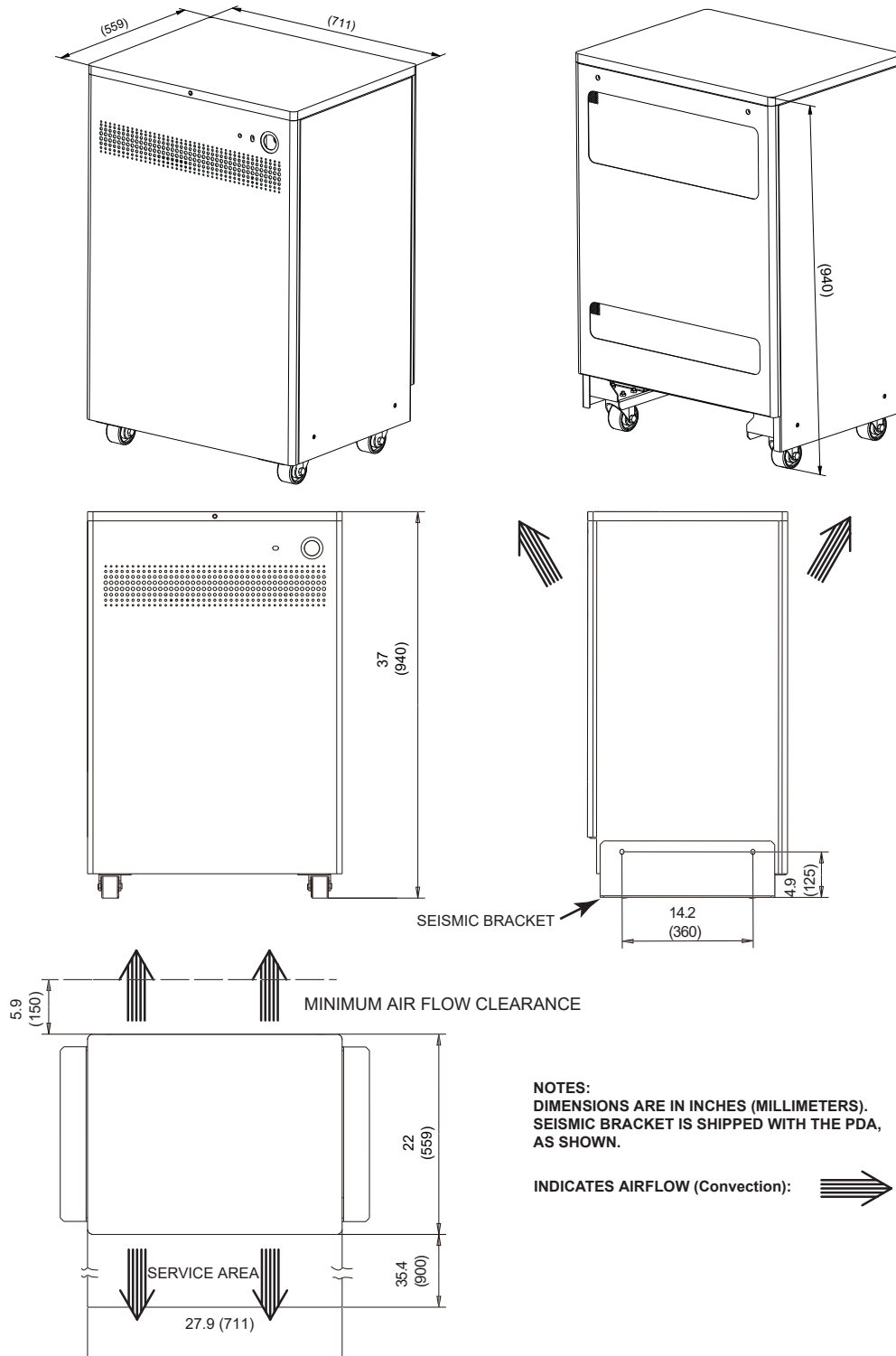

NOTES:
DIMENSIONS ARE IN INCHES (MILLIMETERS).
SEISMIC BRACKET IS SHIPPED WITH THE PDA,
AS SHOWN.

INDICATES AIRFLOW (Convection): 

7.2.5 Console Dimensions

Figure 7-5 Operator's Console



7.2.6 Console Desk Dimensions

Figure 7-6 Console Desk Dimensions

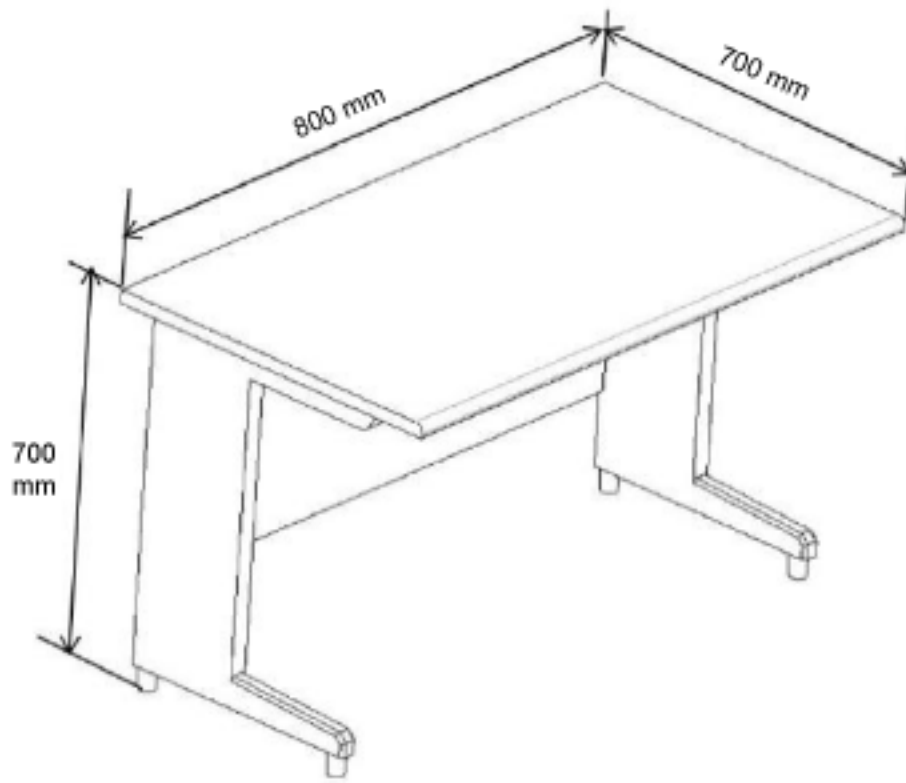

8 Structural and Mounting Requirements

8.1 Overview

8.1.1 Importance of Meeting Structural Requirements

System performance specifications require close consideration of the customer's floor properties. The information in this chapter provides critical information and guidelines that the customer or PMI should communicate to the architect, structural engineer, and contractor prior to construction or renovation. Failure to properly evaluate the customer's floor and ceiling properties may result in limited performance and possible safety hazards.

8.1.1.1 Levelness, Vibration, and Floor Loading

All floors, whether configured to use the recommended GE-supplied anchoring system or an equivalent anchoring method, must meet the requirements for LEVELNESS, VIBRATION, and FLOOR LOADING listed in Minimum Floor Requirements.

8.1.1.2 Seismic Loading

Local laws and building codes in some areas may require the customer's contractor and structural engineer to consider seismic loads. Seismic Mounting provides the information necessary for the customer's contractor and structural engineer to complete the proper seismic calculations.

8.1.1.3 Anchoring

[8.5 GE-Supplied Anchoring on page 64](#) lists the information necessary for the customer's contractor or structural engineer to properly implement the GE-supplied anchoring system, if appropriate for the site. Please note that local laws, building codes, seismic considerations, and building or structural limitations may require the use of anchoring methods other than the GE-supplied anchoring system. In such cases, responsibility for providing an equivalent anchoring method rests solely with the customer's contractor or structural engineer.

Consult your architect, structural engineer, contractor, or PMI to resolve any questions.

NOTICE

Responsibility for providing an approved support structure and mounting method for all floor types, other than those listed in this chapter, rests with the purchaser. General Electric accepts no responsibility for any failure of the support structure or anchoring method, including seismic mounting and anchoring. GE accepts no responsibility for methods other than those listed.

8.2 Ceiling Requirements

The minimum ceiling height above the floor shall measure at least 2400 mm (94.5 in.) or the minimum distance allowed by local laws and codes, whichever is greater.

8.2.1 Electrical Box Requirement

A 152 mm x 152 mm x 102 mm (6 in. x 6 in. x 4 in.) or equivalent ceiling box is required to be flush mounted next to the ceiling plate. There should be two (2) conduits exiting into the box and the box grounded to the mounted plate. The electrical box cover plate must be flush mounted to the finished ceiling and with provision to add a 102 mm x 102 mm (4 in. x 4 in.) centered GE-supplied electrical cover plate.

NOTE

- Additional mounting information is available on the Mavig website. Refer to the Protegra 2 Installation manual.
- Seismic information is also available on the same website.

8.3 Minimum Floor Requirements

8.3.1 Floor Levelness Specifications

8.3.1.1 Critical Specifications

Accurate patient positioning during scanning depends on proper alignment of the gantry and the table. The floor levelness specifications in [Table 8-1 CRITICAL SPECIFICATIONS for Floor Levelness on page 59](#) ensure that the table and gantry height adjusters have enough range to allow proper leveling of the system.

Table 8-1 CRITICAL SPECIFICATIONS for Floor Levelness

Specification	Metric (minimum)	English (minimum)
Levelness	6 mm maximum variance over 3048 mm	1/4 in. maximum variance over 10 ft

8.3.1.2 Floor Levelness Guidelines

Consider the following factors when determining floor levelness:

- Factors that can disturb the levelness of a weak floor, including:
 - Moving weights such as gurneys or heavy personal equipment.
 - Changes in the system's center-of-gravity when the table moves, as the table can carry a load capacity of up to 180 kg (396 lbs).
- Resilient tile, carpeting, or equivalent that may yield or compress over time. At sites with such floor coverings, be sure to cut away the tile or carpeting where the table and gantry adjusters touch the floor to expose the stable base material upon which to seat the adjusters.

- Floor shims are NOT PERMITTED.
- Refer to the steps listed in [8.3.1.3 Measuring Floor Levelness on page 60](#) and to [8.3.1.3 Measuring Floor Levelness on page 60](#) to check whether the floor of the scan suite meets the floor levelness specifications for the system.

8.3.1.3 Measuring Floor Levelness

8.3.2 Walls

8.3.2.1 Scan Window

The recommended patient viewing window dimensions are 1219 mm wide x 1067 mm high (48 in. x 42 in.). The location of the window is dependent on the position of the operator workspace position. Consult Radiation Protection Requirements and a qualified radiological health physicist for radiation protection requirements of the window glass (lead content and thickness).

NOTE

The operator at the operator workspace must be able to view the patient during a scan.

8.3.3 Floor Vibration Specifications

8.3.3.1 Requirements

CT systems are sensitive to vibration and may display limited performance if exceeding the vibration limits listed below. The band of frequencies in which systems exhibit the most sensitivity appears at or near the resonant frequencies of the gantry and the patient table, the latter of which varies depending on patient mass and location. These frequencies fall within the following ranges:

- Patient Table: 2 - 10 Hz
- Gantry: 8 - 14 Hz

Floor vibration from any intermittent or continuous source, such as walking, running, exercising, mechanical equipment, and traffic, must not exceed the levels shown in [Figure 8-1 Allowable floor vibration in velocity units compared to ISO class A & B limits on page 61](#) or [Figure 8-2 Allowable floor vibration in acceleration units compared to ISO class A & B limits on page 62](#), as represented by the solid line labeled CT system/Table. These figures compare this limit to the limits of what the AISC (American Institute of Steel Construction) and the ISO (International Organization for Standardization) call Class A (VC-A) and Class B (VC-B).

NOTE

In Figure 8-1 Allowable floor vibration in velocity units compared to ISO class A & B limits on page 61 and Figure 8-2 Allowable floor vibration in acceleration units compared to ISO class A & B limits on page 62 the symbol μ represents 10^{-6} .

The preferred format for measuring vibration is velocity versus frequency, as shown in Figure 8-1 Allowable floor vibration in velocity units compared to ISO class A & B limits on page 61. However, should it prove necessary to measure acceleration and there is no means to convert the measured data to velocity, then use the equivalent acceleration limit shown in Figure 8-2 Allowable floor vibration in acceleration units compared to ISO class A & B limits on page 62, derived from the velocity spectrum.

Figure 8-1 Allowable floor vibration in velocity units compared to ISO class A & B limits

Frequency [Hz]	Velocity [$\mu\text{m/s}$, rms]
4	100
10	40
12.5	40
16	50
80	50

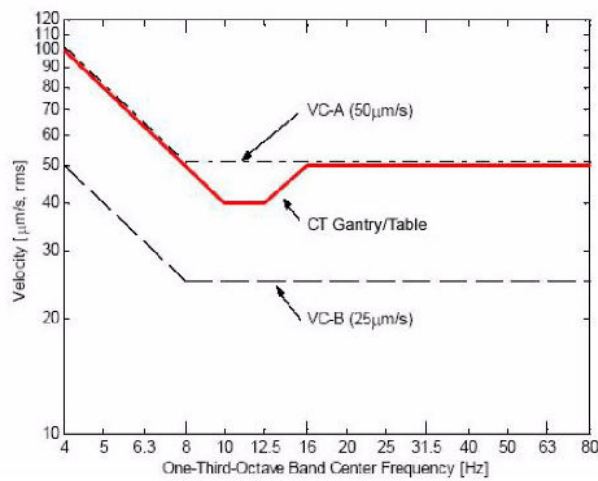
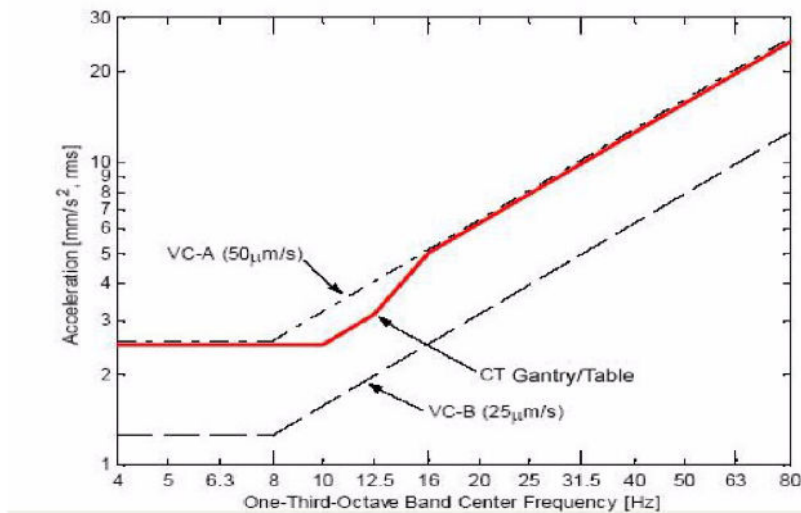

Figure 8-2 Allowable floor vibration in acceleration units compared to ISO class A & B limits

Frequency [Hz]	Acceleration [mm/s ² , rms]
4	2.5
10	2.5
12.5	3.1
16	5
80	25



8.3.3.2 Sources of Floor Vibration

Consider that vibrations strong enough to affect the floor may emanate from the following sources in and around the scanning facility, requiring possible isolation of the floor or structure from them:

- Hospital power plants housing pumps, motors, air handling equipment, or air conditioning units
- Hallway foot traffic
- Elevators
- Parking lots
- Roadways
- Subways
- Trains
- Heliports

8.4 Floor Loading and Component Weights

The customer's contractor and structural engineer should use the information in [Table 8-2 Revolution ACTs Component Weight and Floor Loading Data on page 63](#) to help determine if the floor structure in the scan suite possesses sufficient strength to support the weight of the system.

Table 8-2 Revolution ACTs Component Weight and Floor Loading Data

System Component	NET Weight kg (lb)	Overall Height x Width x Depth mm (in.)	Load Pattern mm (in.)
Gantry	830 (1829.8)	1741 x 1783 x 921 (68.5 x 70.2 x 36.3)	Four leveling pads 63.5 mm (2.5 inch) diameter
Dollies	200 (441)	-	-
Aakash Table <i>with 180 kg (396 lb) Load Capacity</i>	330 (727.5)	854 x 583 x 3620 (33.7 x 23.0 x 142.5)	Four leveling pads 34mm (1.3 inch) diameter
Power Distribution Unit (PDU-36)	275 (606)	1062 x 700 x 550 (41.8 x 27.6 x 21.7)	Four casters
Power Distribution Adapter (PDA)	317 (698)	940 x 711 x 559 (37 x 27.9 x 17.5)	Four casters
Console (Z420)	20 (44)	448 x 178 x 445 (17.6 x 7.0 x 17.5)	-
Console (Z440)	17.5 (38.5)	432 X 169 X 455 (17.0 X 6.65 X 17.9)	-
Console (Z4G4)	10.2 (22.5)	386 X 169 X 445 (15.2 X 6.65 X 17.5)	-
Console (Z4G5)	20 (44.1)	386 X 169 X 459 (15.2 x 6.7 x 18.1)	-

8.4.1 Floor Loading and Anchoring Guidelines



ESSENTIAL TO SAFETY!

Follow the floor loading and anchoring guidelines below when preparing a site for system installation:

- The table and gantry require secure anchoring to the scan room floor. The power distribution unit and the console sit on the floor with casters; anchoring of these components to the floor is optional, unless required because of seismic considerations.
- For total floor load of Revolution ACTs with Aakash table and no UPS, refer to [Table 8-2 Revolution ACTs Component Weight and Floor Loading Data on page 63](#).
- When carrying the heaviest possible patient, the table-gantry-footswitch assembly represents a concentrated load within the scan room. Refer to [Table 8-2 Revolution ACTs Component Weight and Floor Loading Data on page 63](#) for total weight.
- Anchors mount through the table and gantry supports. Use the floor template or its dimensions to locate the table and gantry support positions within the scan room, making sure that any anchors that pass through the supports clear all structural beams and interferences in the floor.
- If a loading analysis determines that the gantry and table position should change relative to their position on the GE site print, be sure to take into account the clearance requirements in

4 [Regulatory Requirements on page 31](#) and 5 [Service Clearance Requirements on page 39](#) when determining an appropriate location for the system.

- Hospitals and scanning facilities throughout the world should follow the instructions and adhere to the flooring requirements specified by GE:
 - Wood floors often require substantial reinforcements, hence GE strongly suggest not to use wooden floors for anchoring table and gantry.
 - Temperature variation in blacktop or marble floors allow anchor movement and pullout, hence GE strongly suggests not to use these floors for anchoring table and gantry.
 - Customers should use concrete floors with a minimum thickness of 102 mm (4 in.) for Gantry and Table. Figure 8-5 describe embedment depth, hole depth, minimum concrete thickness etc. for table anchoring.
 - Customers should use GE supplied/ specified anchors only.

 **CAUTION**



ESSENTIAL TO SAFETY!

GE strongly suggests not to use any alternate anchoring methods; GE accepts no responsibility for any failure of the support or the anchoring method, including those used for seismic mounting. GE accepts no responsibility for methods other than those listed. The customer is responsible for meeting all code requirements specific to the site and for this product when using alternate system anchoring.

8.5 GE-Supplied Anchoring

GE supplies anchors for mounting the table and gantry. The console and power distribution unit do not require anchoring to the floor. It is the responsibility of the customer to have a structural engineer and trained contractor to use either the GE-supplied anchoring method or to provide an equivalent anchoring method to mount the table and gantry to the floor. Consult your architect, structural engineer, contractor, or PMI to resolve any questions.

 **WARNING**



POTENTIAL FOR PATIENT INJURY!

AN IMPROPERLY SECURED SYSTEM WILL CAUSE DAMAGE OR PERSONAL INJURY.

SYSTEM CAN MOVE OR TIP DURING OPERATION IF NOT PROPERLY SECURED.

PATIENT SAFETY DURING SYSTEM OPERATION REQUIRES PROPER ANCHORING OF THE SYSTEM.

8.5.1 Specifications of GE-supplied Anchors

[Table 8-3 GE-Supplied Anchor Specifications on page 65](#) lists the specifications of GE-supplied anchors for the system. There are two types of anchors used in this product depending on manufacturing date. Both anchors can be used for anchoring of Gantry, GT1700V and VT2000 Table. However VT2000X Table (1675lbs) Table must use 2106573 (8 in.) anchor. For a detailed view, including dimensions and additional specifications, see [Figure 8-3 Typical Floor Anchor, Gantry on page 66](#) of this section.

Table 8-3 GE-Supplied Anchor Specifications

GE-Supplied Anchors	Gantry	Aakash Table
Part Number	5479997	5535487
Description	Anchor Stud 12mm Diameter 205mm Length	HILTI ANCHOR STUD 12MM DIAMETER 175MM LENGTH
Diameter	12 mm (0.47 in.)	12 mm (0.47 in.)
Length	205 mm (8.1 in.)	175 mm (6.9 in)

8.5.2 Requirements for Using GE-supplied Anchors

Use of GE-supplied anchors (Gantry, P/N 5479997; Table, P/N 5535487) shall adhere to the following requirements:

- Use the GE-supplied anchors ONLY when mounting components on concrete floors.
- Adhere to all anchoring requirements listed in [Table 8-4 Table and Gantry Anchoring Requirements on page 65](#).
- Any anchors showing more than 21 mm (~0.9 in.) of thread above the torqued nut requires the installation of a second anchor in the closest adjacent mounting location. The second anchor shall meet the same requirements in [Figure 8-3 Typical Floor Anchor, Gantry on page 66](#).
- Non-seismic installations must use a minimum of four (4) anchors to mount the gantry and four (4) anchors to mount the table.
- Fully engage the Adjuster Lock Rings (P/N 5405132) with at least one full thread showing below the notched portion on the Adjuster Screw.

NOTE

The table does not have the Adjuster Lock Rings shown in [Figure 8-3 Typical Floor Anchor, Gantry on page 66](#) of this section.

Table 8-4 Table and Gantry Anchoring Requirements

Mounting Requirements	Gantry	Aakash Table
Minimum Floor Thickness	102 mm (4 in.)	102 mm (4 in.)
Recommended Drilling Depth	95 mm (3.74 in.)	90 mm (3.74 in.)
Minimum Anchor Embedment	80 mm (3.15 in.)	80 mm (3.15 in.)
Available Alternate Anchor Locations	Yes	Yes
Shipped Anchor Size	205 mm (8.1 in.)	175 mm (6.9 in)
Alternate Anchoring Methods	Yes (see note, above)	Yes (see note, above)
Floor Levelness Requirement	6 mm (1/4 in.) over 3 m (10ft)	6 mm (1/4 in.) over 3 m (10ft)

Figure 8-3 Typical Floor Anchor, Gantry

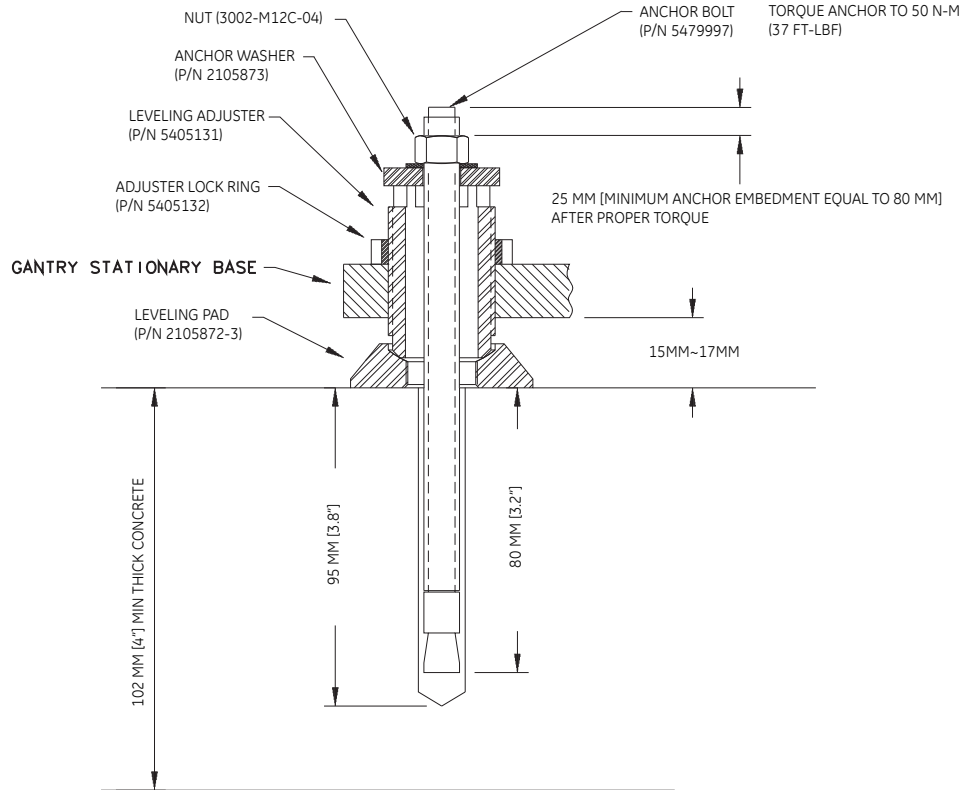
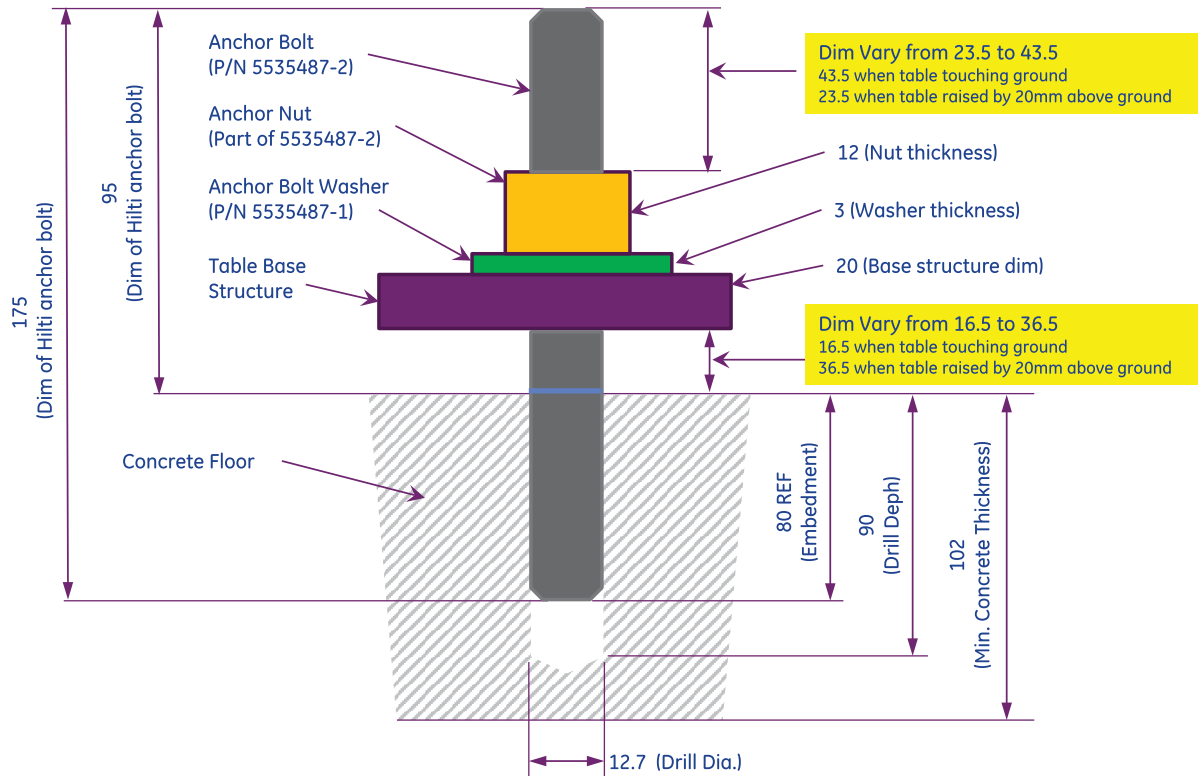

Figure 8-4 Aakash Table Anchoring



ALL DIMENSION ARE IN "mm"

8.6 Seismic Mounting

8.6.1 Overview

Refer to the guidelines in this section when mounting the system in seismic zones:

- Responsibility for proper seismic mounting rests with the customer. Refer to all applicable laws and codes for your locality.
- The customer's contractor often supplies a state-certified print or equivalent, showing seismic installation instructions.
- Consider seismic requirements for ceiling-mounted fixtures and refer to the appropriate installation instructions for ceiling-mounted fixtures.

PDU seismic brackets (2354563-2) and the PDU shipping kit (5453382-2) are shipped with the PDU. Detail bracket installation procedure refer to Installation Manual.

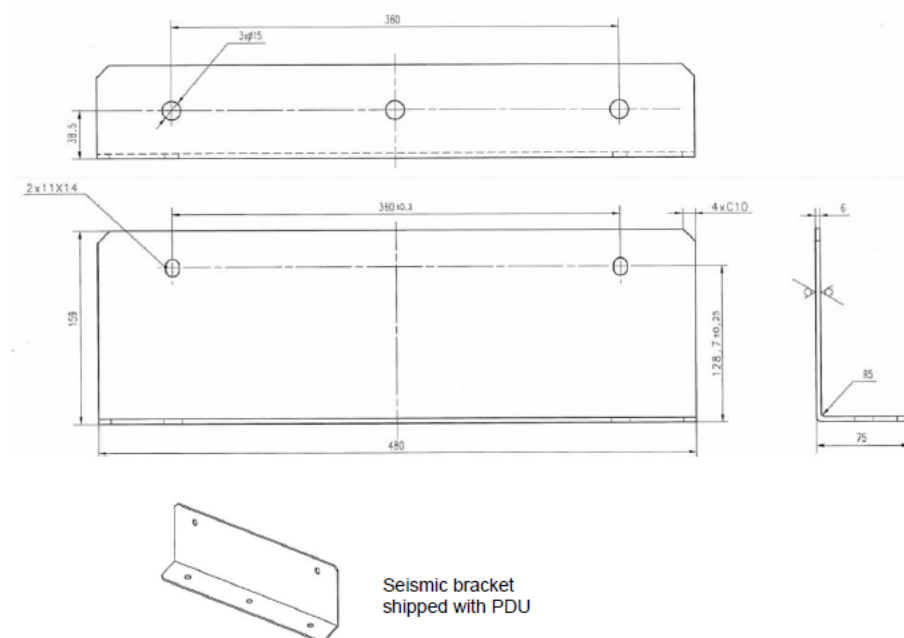

8.6.2 Center-of-Gravity Information

The information in the following figures provides the customer's contractor and/or structural engineer with center-of gravity information to assist in seismic calculations for the system:

- Gantry: [Figure 8-5 Gantry Center of Gravity on page 68](#)
- Table: [Figure 8-6 Aakash Table Center of Gravity without Patient on page 68](#) and [Figure 8-7 Aakash Table Center of Gravity with 180kg Load Capacity on page 68](#)
- Power Distribution Unit: [Figure 8-8 PDU Center of Gravity on page 69](#) (PDU Seismic Mounting Bracket)

Figure 8-5 Gantry Center of Gravity

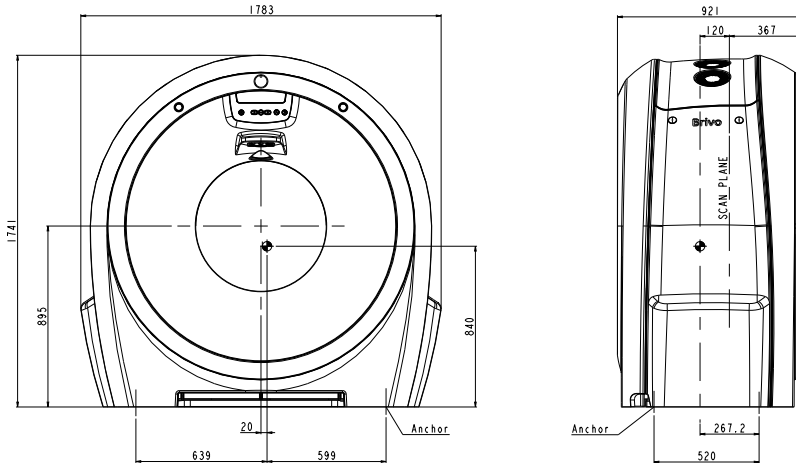

Figure 8-6 Aakash Table Center of Gravity without Patient

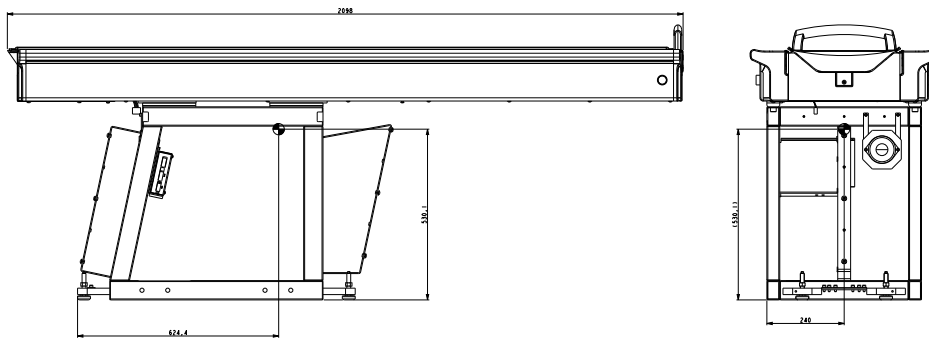
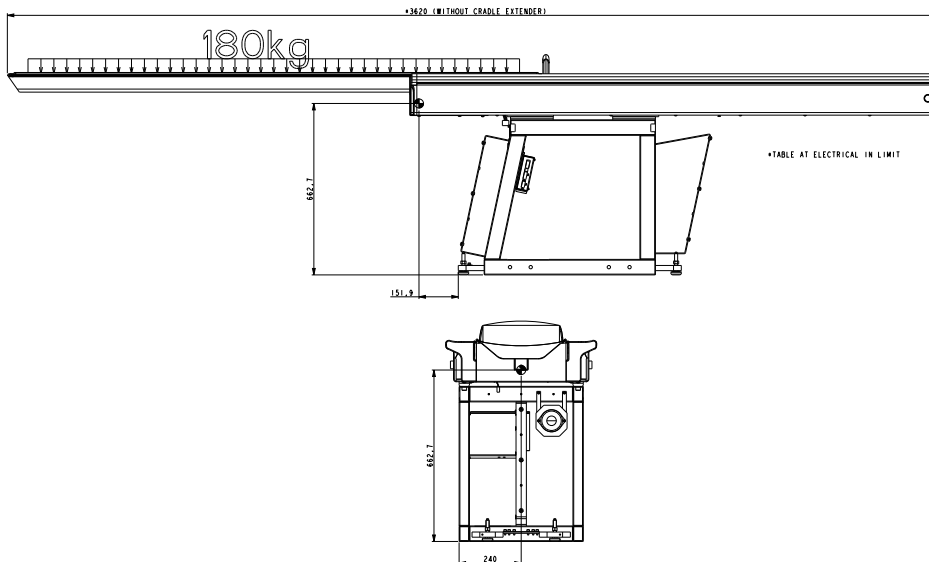

Figure 8-7 Aakash Table Center of Gravity with 180kg Load Capacity



NOTE

Center of Gravity location marked above includes the mass of a maximum load capacity on the table with a fully extended cradle.

Figure 8-8 PDU Center of Gravity

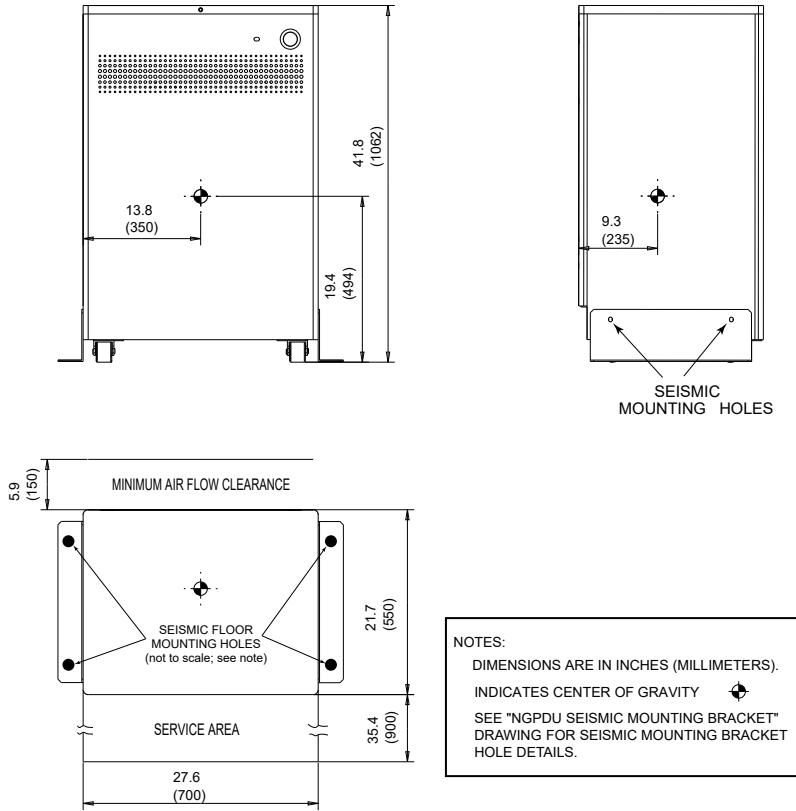

9 Environmental Requirements

Ensure the operational readiness and proper system calibration of HVAC prior to installation. Maintain the environmental conditions listed below at ALL times, including over nights, weekends, and holidays. Shut down the CT system if air conditioning is not working. When shutting down the system for major repair, you may also shut down the air conditioning.

9.1 Temperature and Humidity Specifications

Environmental specifications apply to the table, gantry, power distribution unit, and console.

NOTICE

Exceeding environmental specifications may adversely affect system operation and image quality.

9.1.1 Temperature (Scan and Control Rooms)

Table 9-1 System Temperature Limits

Maximum allowable ambient room temperature:	26°C (79° F)
Recommended ambient room temperature:	22°C (72°F)
Minimum allowable ambient room temperature:	18°C (64°F)

NOTE

Be certain to account for ANY cooling equipment cycle control range, ensuring that the maximum and minimum ambient room temperatures do not exceed those shown in [Table 9-1 System Temperature Limits on page 70](#) during room thermal cycling. For example, if the HVAC is capable of $\pm 2^{\circ}\text{C}$ control, then the limits would be $20^{\circ}\text{C} - 24^{\circ}\text{C}$ to maintain absolute limits.

9.1.2 Humidity (Scan Room & Control Room)

Table 9-2 System Humidity Limits

Maximum allowable non-condensing relative humidity:	60%
Minimum allowable non-condensing relative humidity:	30%

9.1.3 Other Guidelines

- Accurate determination of hospital room environmental conditions may require the temporary installation of a temperature and humidity recorder near the location designated for system installation. Record temperature and humidity readings before and after installation to verify the site's true environmental conditions.
- Consider heating, ventilating, air conditioning (HVAC) needs, and redundancy (back-up). An air conditioner with two compressor units rather than one, may prevent system downtime. A

redundant (back-up) air conditioner permits CT system operation during an extended repair of the primary air conditioner.

9.2 Cooling Requirements

Use [Table 9-3 System Heat Output on page 71](#) to assist in cooling requirements planning. Gantry operation requires over half of the cooling utilized by your system. Contact an HVAC specialist to determine optimal placement of the thermostat and all HVAC vents, bearing in mind that:

- Gantry air INTAKE occurs across the BOTTOM of the gantry.
- Gantry air EXHAUST occurs across the TOP of the gantry.

Table 9-3 System Heat Output

System Component	Max BTU/HR	Max Watt
Gantry maximum (See Note 1)	11945	3500
Aakash Table	700	200
Power Distribution Unit	2389	700
Power Distribution Adapter (PDA)	2389	700
Scan Room Subtotal (without PDA)	15034	4400
Scan Room Subtotal (with PDA)	17423	5100
Console (HP Z420)	3686	1080
Console (HP Z440)	2746	805
Console (HP Z4G4)	2559	750
Console (HP Z4G5)	3700	1800
LCD Monitor	102	30
Eizo Monitor	171	50
Control Room Subtotal (Z420)	3788	1110
Control Room Subtotal (Z440)	2848	835
Control Room Subtotal (Z4G4)	2661	780
Control Room Subtotal -(Z4G5) with Eizo monitor	3871	1850
Max. System Total (with Z420) (Max without PDA)	18822	5510
Max. System Total (with Z420)(Max with PDA)	21211	6210
NOTE 1: Maximum heat output reached at tube change (Detailed Calibration).		
NOTE 2: Heat output does not include heat from room lighting, personnel, or non-CT equipment.		

Refer to [Figure 7-1 Gantry Dimensions with Covers on page 52](#) and [Figure 7-3 Power Distribution Unit on page 54](#) for Gantry and PDU air flow requirements.

[Figure 9-1 HVAC Air Vent Placement in Scan Room on page 72](#) and [Figure 9-2 HVAC Air Vent Placement in Control Room on page 72](#) show the recommended placements of the thermostat and HVAC vents (intake and output) for the scan and control rooms.

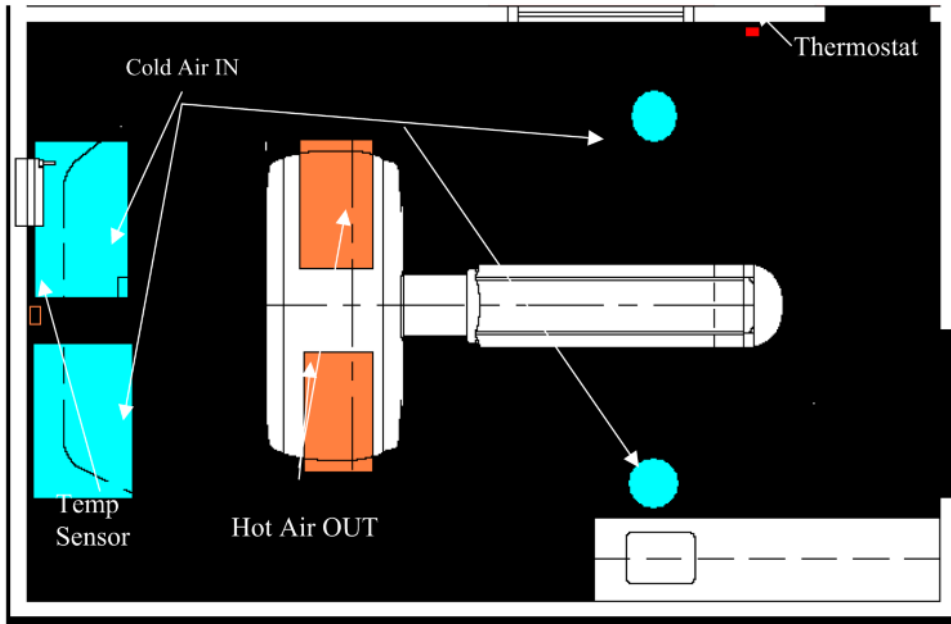
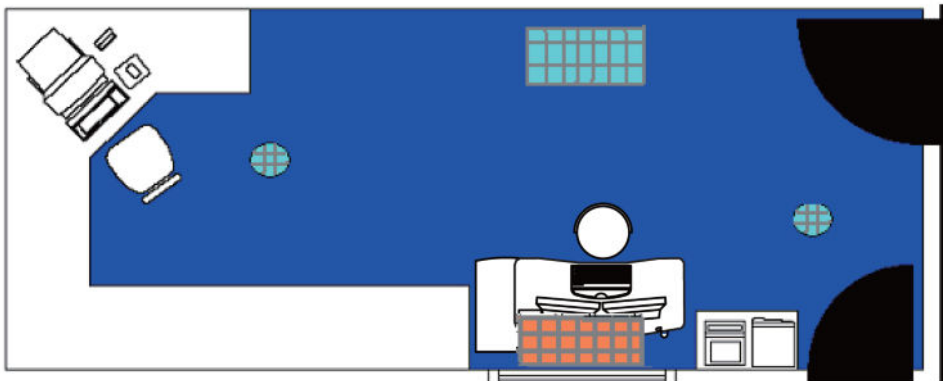
Figure 9-1 HVAC Air Vent Placement in Scan Room**Figure 9-2 HVAC Air Vent Placement in Control Room**

9.3 Altitude

The system shall meet all functional and performance specifications when placed in a room that is at an elevation of -150 m to 2,400 m (-492 ft to 7,875 ft) above sea level.

9.4 Electro-Magnetic Interference (EMI)

9.4.1 Gantry

Locate the gantry in ambient static magnetic fields of less than 0.1 mTesla (1 Gauss) to guarantee the specified imaging performance. Ambient AC magnetic fields must measure below 1 μ Tesla (10 mGauss) peak.

9.4.2 Console / Computer Equipment

Locate computer equipment in ambient static magnetic fields of less than 1 mTesla (10 Gauss) to guarantee data integrity (see Figure 1).

9.4.3 PDU and PDA

The PDU/PDA produces an electromagnetic field that radiates outward from its cabinet in all directions. Do not place the gantry or patient table within 0.3 meters (12 inches) of the edge of the Power Distribution Unit/Adapter. Do not place other sensitive electronics (e.g. the operator console or computer equipment) within 1.0 meters (39 inches) of the edge of the Power Distribution Unit in any direction, including above or below it. The UPS is not classified as sensitive electronics. (see [Figure 9-3 Sample Room Layout \(Showing Approximate EMI Requirements\) on page 74](#)).

9.4.4 EMI Reduction

If you suspect the presence of fields of excessive EMI, consult GE Sales & Service for recommendations. Consider the following when attempting to reduce EMI:

- External field strength decreases rapidly with distance from source of the magnetic field.
- External leakage magnetic field of a three-phase transformer measures much less than that of a bank of three single-phase transformers of an equivalent power rating.
- Large electric motors constitute a source of substantial EMI.
- High-powered radio signals constitute a source of EMI.
- Maintain good screening of cables and cabinets.
- Consider and measure EMI fields of sites with main facility power running UNDER the floor or WITHIN the walls or ceilings of the scan room.
- Pay special attention to power substations and high-voltage power lines in proximity to the scan facility.
- If any concerns remain regarding excessive EMI fields, be sure to measure to confirm that your site meets all required specifications.

9.4.5 Equipment EMI "Envelopes"

Figure 9-3 Sample Room Layout (Showing Approximate EMI Requirements)

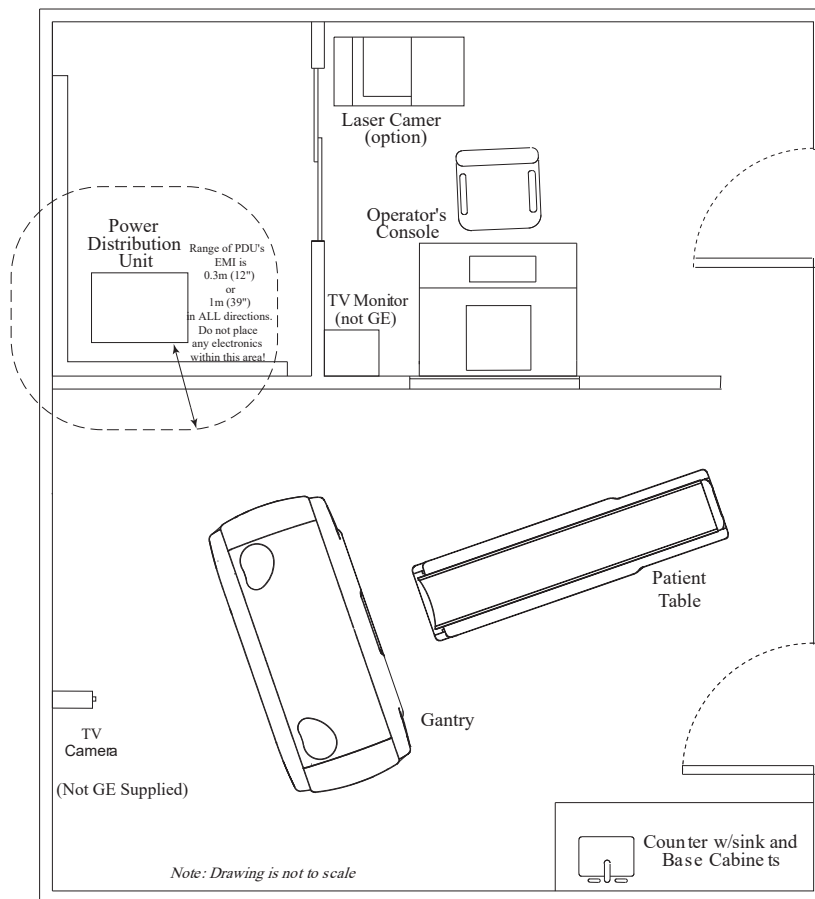

9.5 Electro-Magnetic Compatibility (EMC)(Reference IEC 60601-1-2)

9.5.1 General Scope

This system complies with IEC60601-1-2 Edition 4.0 [2014] EMC standard for medical devices. The system is suitable to use in the electromagnetic environment, as per the limits and recommendations described in the following tables:

- Emission Compliance level and limits (Table 9-4).
- Immunity Compliance level and recommendations to maintain equipment clinical utility (Table 9-4 and Table 9-6).



NOTE

This system complies with the EMC standard when used with supplied cables. If different cable lengths are required, contact a qualified GE service representative for advice.

9.5.2 Electromagnetic Emission (Reference IEC 60601-1-2)

The system is intended for use in the electromagnetic environment specified below. The customer or the user of the system should assure that it is used in such an environment.

Table 9-4 Electromagnetic Emissions

Emissions Test	Compliance	Electromagnetic Environment Guidance
RF emissions CISPR 11	Group 1	The system uses RF energy only for its internal function. Therefore, its RF emissions are very low and are not likely to cause any interference in nearby electronic equipment.
RF emissions CISPR 11	Class A	
Harmonic emissions IEC 61000-3-2	Not applicable	When installed in such a shielded location, the system is suitable for use in all establishments other than domestic and those directly connected to the public low-voltage power supply network that supplies buildings used for domestic purposes.
Voltage fluctuations/ flicker emissions IEC 61000-3-3	Not applicable	

9.5.3 Electromagnetic Immunity (Reference IEC 60601-1-2)

The system is intended for use in the electromagnetic environment specified below. The customer or the user of the system should assure that it is used in such an environment.

Table 9-5 Electromagnetic Immunity

Immunity Test	EC 60601-1-2 Test Level	Compliance Level	Electromagnetic Environment Guidance
Electrostatic discharge (ESD) IEC 61000-4-2	± 6 kV contact ± 8 kV air	± 6 kV contact ± 8 kV air	Floors should be wood, concrete, or ceramic tile. If floors are covered with synthetic material, the relative humidity should be at least 30%.
	± 8 kV contact ^{*1} ± 15 kV air ^{*1}	± 8 kV contact ^{*1} ± 15 kV air ^{*1}	
Electrical fast transient/burst IEC 61000-4-4	± 2 kV for power supply lines	± 2 kV for power supply lines	Mains power quality should be a typical commercial or hospital environment
	± 1 kV for input/output lines at 100kHz rate	± 1 kV for input/output lines at 100kHz rate	
Surge IEC 61000-4-5	± 1 kV line-line ± 2 kV line-earth	± 1 kV line-line ± 2 kV line-earth	Mains power quality should be a typical commercial or hospital environment.
Voltage dips, short interruptions and voltage variations on power supply input lines IEC 61000-4-11	< 5% U_T (>95 % dip in U_T) for 5 seconds INT 0% U_T , 250/300 cycle (5 seconds) ^{*1}	< 5% U_T (>95 % dip in U_T) for 5 seconds INT 0% U_T , 250/300 cycle (5 seconds) ^{*1}	Mains power quality should be a typical commercial or hospital environment. If the user of the system requires continued operation during power mains interruptions, it is recommended that the system is powered from a partial Uninterruptible power supply or a battery.

NOTE: U_T is the AC mains voltage prior to application of the test level.

Continues on the next page

The system is intended for use in an electromagnetic environment in which radiated RF disturbances are controlled. The customer or the user of the system can help prevent electromagnetic interference by maintaining a minimum distance between portable and mobile RF communications equipment (transmitters) and the system as recommended below, according to the maximum output power of the communications equipment.

Table 9-6 Recommended Separation Distances

Rated Maximum Output Power (P) of Transmitter Watts (W)	Separation Distance (Meters) by Frequency of Transmitter		
	150 kHz to 80 MHz $d = \left[\frac{3.5}{3} \right] \sqrt{P}$	80 MHz to 800 MHz $d = \left[\frac{3.5}{3} \right] \sqrt{P}$	800 MHz to 2.5GHz/ 2.7GHz ^{*1} $d = \left[\frac{7}{3} \right] \sqrt{P}$
0.01	0.12	0.12	0.23
0.1	0.37	0.37	0.74
1	1.17	1.17	2.33
10	3.69	3.69	7.38
100	11.7	11.7	23.3

For transmitters rated at a maximum output power not listed above, the separation distance can be estimated using the equation in the corresponding column, where P is the maximum output power rating of the transmitter in watts (W) according to the transmitter manufacturer.

NOTE 1:At 80 MHz and 800 MHz, the separation distance for the higher frequency range applies.

NOTE 2:These guidelines may not apply in all situations. Electromagnetic propagation is affected by absorption and reflection from structures, objects, and people.

*1 Only for the equipment IEC 60601-1-2:2014 (EMC4.0) compliant.

As an example, keep a 1 W mobile phone (800 MHz to 2.7 GHz carrier frequency) at least 2.3 m from the system (in order to avoid image interference risks.) LIMITATIONS MANAGEMENT: Adhering to the distance separation recommended in [Table 9-6 Recommended Separation Distances on page 77](#), between 150 KHz and 2.7 GHz, reduces disturbances recorded at the image level, but may not eliminate all disturbances. However, when installed and operated as specified, the system maintains its essential performance by continuing to acquire, display, and store diagnostic quality images safely.

9.5.4 Installation Requirements and Environment Control

In order to minimize interference risks, the following requirements apply.

Cable Shielding and Grounding

All interconnect cables to peripheral devices must be shielded and properly grounded. Use of cables not properly shielded and grounded may result in the equipment causing radio frequency interference.

The manufacturer is not responsible for any interference caused by using other than recommended interconnect cables or panels, or by unauthorized changes or modifications to this equipment. Unauthorized changes or modifications could void the users' authority to operate the equipment.

All interconnect cables to peripheral devices must be shielded and properly grounded, except when technologically prohibited. Use of cables not properly shielded and grounded may result in the equipment causing radio frequency interference.

9.6 System Component Noise Levels

Maximum Gantry Audible Noise Level The maximum ambient noise level is produced by the gantry during a CT scan acquisition. It is less than 70 dBA when measured at a distance of one meter from the nearest gantry surface, in any direction.

10 Radiation Protection Requirements

10.1 Shielding Requirements

NOTICE

Engage a QUALIFIED RADIOLOGICAL HEALTH PHYSICIST to review your scan room shielding requirements, taking into consideration:

⚠ WARNING

Scatter radiation levels within the scanning room (see [Figure 10-1 Typical stray radiation in \$\mu\text{Gy}\$ per 100mAs –Horizontal plane for body on page 81](#) and [Figure 10-2 Typical stray radiation in \$\mu\text{Gy}\$ per 100mAs –Vertical plane for body on page 82](#)).

Equipment placement.

Weekly projected work-loads (number of patients/day technique (kvp*ma)).

Materials used for construction of walls, floors, ceiling, doors, and windows.

Activities in surrounding scan room areas.

Equipment in surrounding scan room areas (e.g., film developer, film storage).

Room size and equipment placement within the room relative to room size.

Scatter survey figures depicts measured radiation levels within the scanning room, while scanning a 32 cm CTDI phantom and using a large filter, with the technique shown. Use the mAs, kV and aperture scaling factors shown in [Table 10-1 Shielding Requirements Scaling on page 79](#) to adjust exposure levels to the scan technique used at the site.



NOTE

Actual measurements can vary. Expected deviation equals $\pm 15\%$, except for the 5 mA and 1 mm techniques, where variation may be greater (up to a factor of 2), due to the inherent deviation in small values. The maximum deviation anticipated for tube output equals $\pm 40\%$.

Table 10-1 Shielding Requirements Scaling

Changed Parameter	Multiplication Factor
mAs	new mAs/100
80 kV	0.24
100 kV	0.45
120 kV	0.71
140 kV	1.00
1.25mm aperture	0.09

Continues on the next page

Table 10-1 Shielding Requirements Scaling (Table continued)

Changed Parameter	Multiplication Factor
5 mm aperture	0.34
10 mm aperture	0.56
15 mm aperture	0.81
20 mm aperture	1.00

 **WARNING**

This publication uses mGy (micrograys) to measure radiation levels. The conversion factor from mR to mGy (micrograys) is: 1 mR = 8.76 mGy.

Typical Scatter Survey Plots (Body Filter)



NOTE

In the Revolution ACTs CT system, the Akash collimator houses only a single filter (Bowtie filter). Consequently, the head and body filters exhibit identical stray radiation values.

Figure 10-1 Typical stray radiation in μGy per 100mAs –Horizontal plane for body

Technique:

140kV, 100mA,10mm (8x 1.25mm)

Mode: Static

Tube position: 12’o Clock

Z=0		X-Axis										
Y-Axis	Distance in Meters	-2.5	-2	-1.5	-1	-0.5	0	0.5	1	1.5	2	2.5
	-2	x	x	0.69	0.86	1.10	x	x	x	x	x	x
	-1.5	x	0.36	0.81	1.25	1.86	2.04	1.67	1.11		0.04	x
	-1.0	0.036	0.06	0.15	1.62	3.53	5.17	3.46	0.31	0.42	0.06	0.04
	-0.5	0.036	0.04	0.04	0.03	4.94	19.81	0.23	0.22	0.08	0.04	0.03
	0.0	0.056	0.09	0.21	0.28	x	x	x	0.20	0.13	0.08	0.06
	0.5	0.081	0.11	0.24	0.43	6.67	12.50	6.44	0.56	0.16	0.11	0.06
	1.0	0.117	0.15	0.46	1.69	3.15	4.00	2.83	1.63	0.56	0.17	x
	1.5	0.117	0.36	0.81	1.22	1.57	1.83	1.47	1.11	0.75	0.38	x
	2.0	0.228	0.44	0.64	0.81	0.92	0.91	0.87	0.75	0.58	x	x
	2.5	x	0.34	0.48	0.33	0.59	0.63	0.58	0.53	0.45	x	x
	3.0	x	0.31	0.37	0.40	0.42	0.42	0.42	0.39	x	x	x
		x	x	x	x	x	x	x	x	x	x	x

Figure 10-2 Typical stray radiation in μGy per 100mAs –Vertical plane for body

Technique:

140kV, 100mA, 10mm (8x 1.25mm)

Mode: Static

Tube position: 12'o Clock

X=0		Y-Axis								
Distance in Meters		2.5	2	1.5	1	0.5	0	0.5	1	1.5
Z-Axis	1.5	0.46	0.30	0.51	0.56	0.30	X	0.05	0.16	0.43
	1	0.24	0.34	0.57	1.33	0.59	X	0.09	1.05	1.19
	0.50	0.24	0.44	0.70	1.44	4.44	X	3.36	0.95	0.45
	0.00	0.09	0.23	0.64	1.56	7.08	X	5.90	1.47	0.53
	-0.50	x	x	x	x	3.86	X	4.79	1.19	0.55

11 Network Requirements

11.1 Network Connections

The network requirements listed in this chapter should allow you to connect the system to:

- Hospital/facility networks
- Filming cameras
- PACS
- Workstations
- Patient Information Systems

11.1.1 Network Type

Revolution ACTs systems require a broadband network connection.

11.1.2 Network Speed

The customer and the customer's IT contact should ensure that the site provides access to broadband using one of the following interface types:

- 100BASE-TX (100 Mbit/s)
- 1000BASE-T (1000 Mbit/s [1 Gbit/s]).

11.1.3 Network Cable Routing

The CT system connects to the facility's network through the console. To enable proper network cabling, the customer and the customer's IT contact should:

- Provide an RJ45 wall outlet within 2 m (79 in.) of the console location.
- Provide a patch cable, not to exceed 3.05 m (10 ft), to connect the console to a wall box. (See Notes on [Figure 13-3 Interconnection Runs on page 96](#))
- Complete any cable duct-work or conduit installation that the customer site-unit might require to route connecting network cables to the workstation, camera, and console.
- Ensure that the run from the hospital/facility switch to the CT wall outlet does not exceed 88 m (290 ft). Bandwidth performance degrades significantly when the length exceeds 91 m (300 ft).
- Use of STP (Shielded Twisted Pair) cable is not allowed.

11.2 Customer Broadband Responsibilities

11.2.1 Contact GE to Find Zone Broadband Specialist

Contact your GE PMI to obtain the name of the zone broadband specialist who will:

- Work with the Customer Champion to complete any identified infrastructure changes.
- Provide IP addresses for new CT equipment.
- Provide a VPN compatible appliance that will support the IPSec tunneling protocol and 3DES data encryption.
- Utilize an Internet Service Provider that supports static routing.

11.2.2 Provide GE with IT Contact Information for the Site

Provide your GE PMI with an accurate site address, telephone number, contact name, and e-mail address for the customer IT contact who will:

- Coordinate VPN activities between Radiology/Cardiology and the Information Technology (IT) departments.
- Act as a focal point in assuring site broadband infrastructure meets GE requirements for connection, as determined by a mutual assessment with the GE connectivity team.
- Complete an equipment assessment with the GE connectivity team to determine site readiness for broadband.

11.3 Digital Service and Connectivity Requirements

11.3.1 Background

GE Healthcare provides digital service and asset management through its InSite Connectivity Platform.

InSite RSvP (Remote Service Platform) is the latest connectivity platform that will eventually replace the existing InSite 1 connectivity infrastructure in the Revolution ACTs ES/EX systems starting with the software versions 18IW47.24 and later.

GE can proactively monitor the key operational parameters of your medical systems to provide early warning of potential issues to head off costly and unscheduled downtime. The GE online engineers can recalibrate key operational parameters to help ensure optimal system performance or can dispatch a field engineer to assist in mitigating the issue. Additionally, automated software downloads require reliable connectivity platform to ensure software updates and upgrades in a timely manner to keep the system working efficiently. Software downloads also significantly reduce the time it takes to upgrade your GE Healthcare devices, which means the scheduled system downtime and clinical workflow interruptions are greatly reduced.

The two major technical components of InSite RSvP are Agent and Server. The Agent is installed on the GE Healthcare equipment at the customer sites while the Server resides within GE Healthcare. The role of the Agent is to:

- monitor device performance data on an ongoing basis,

- establish secure communications to the Server via the Internet,
- and send fault information and log files to the Server

The Server uses the secure Web Services to communicate with the Agent. It processes the performance and fault information provided by the Agent.

11.3.2 InSite RSVP Connectivity Requirements (applicable on systems with software version 19IW19.XX and later only)

The Agent establishes connectivity from behind the safety of your corporate firewall, adhering to all the security policies set up by your network administrators. To your network, the Agent is just another computer on the LAN. To set up the InSite 2.0 Agent at your site, the only networking requirements are as follows:

1. A physical connection or a route to an existing enterprise LAN
2. Allow outbound Internet access for the device using HTTPS protocol over port 443

If the CT system is already at or upgrades to software version 18IW47.24 or later, a GE Healthcare Field Engineer will configure network connections for InSite RSVP connectivity according to the site IT requirements.

Customer IT personal would need to ensure the following details to enable connectivity at install:

1. DNS IP Address or Proxy IP address and authentication information as applicable is made available when requested by the GE Field Engineer or Project manager of Installation
2. In case it is required to whitelist, only certain URLs being used by GE Healthcare, here is a list that could be used:
 - 2.1. Enterprise production: <https://insite.gehealthcare.com> Port: 443
 - 2.2. Flexera URL: <https://gehealthcare.flexnetoperations.com/>

InSite RSVP utilizes existing the outbound broadband internet connection. It uses the Secure Sockets Layer (SSL) and complies with the existing firewall rules and Web proxies. Once the Agent has established a secure tunnel, the connection is visible only to InSite RSvP clients and services (applications or user



NOTE

For GEHC Personnel only:

1. If a customer is not able to provide the internet connection then GEHC needs to provide the internet connection along with the required router device.
2. If a customer has GEHC provided internet connection or has GEHC provided router device running on the customer provided internet connection then consult the customer if the same set is to be used.

12 Power Requirements

Be sure to communicate all necessary information in this chapter to the electrical contractor employed at the installation site.

12.1 Introduction

The Power Distribution Unit (PDU) supplied with the system transforms and distributes power to all system components. The PDU constitutes the only power entry point required to operate the system. To minimize voltage regulation effects, keep power wiring between the facility main distribution panel and the PDU as short as possible.

When routing the power wiring, all three-phase wires and ground must run in the same conduit or raceway duct. Route power wires separate from the system control and signal cables, using a separate conduit or trough in a raceway duct. You may use a metallic conduit, floor duct, or surface raceway for running cables, depending upon local codes and practices. However, ensure that cable passageways are large enough to install additional cables with all other cables already installed. Do not use non-metallic conduit.

12.2 System Input Power

12.2.1 Power Source Configuration

The system operates on a three-phase, solidly grounded four-wire wye or Delta power source. The neutral wire does not need to run to the system, (i.e., four-wire connection). If you are running a NEUTRAL wire, terminate it in the A1/MDP box or PDB.

Power Distribution Adapter (PDA) to be used for the input voltages 200V, 220V, 240,420V,440V,460V & 480V along with the PDU.

Power Distribution Unit (PDU) to be used for input voltages 380V, 400V and 415V with the transformer tap setting (refer Installation manual)

A dedicated feeder from the nearest Main Distribution Panel (MDP) should supply power to the system. In accordance with the National Electric Code (U.S.) and similar applicable national and local codes, the site MUST provide a protective disconnect device with LOCK-OUT and TAG-OUT provisions in the power line supplying the PDU, and MUST locate the protective disconnect device within 10 m (32 ft) of the PDU, visible to PDU service personnel. The disconnect device appears as *A1/MDP* or *PDB* in the interconnection schematic diagrams.

12.2.2 PDA RatingNGPDU Rating

- **Configuration:** Three-phase + Neutral line with full sized ground wire
- **Line Frequency:** 50/60 Hz
- **Voltage:** 3 Phase 200 // 240, 380 // 480 VAC
- **Transients:** 50kVA

- **Continuous:** 17kVA

12.2.3 PDU Rating

- **Configuration:** Three-phase + Neutral line with full sized ground wire
- **Line Frequency:** 50/60 Hz
- **Voltage:** 3Ph 380/400/415V
- **Transients:** 40kVA @ 0.85PF
- **Continuous:** 6.3kVA

12.2.4 System Rating

The system operates on three-phase power that meets the following specifications:

- Input Voltage: 3 Phase 200 // 240, 380 // 480 VAC \pm 10%
- Capacity: 40kVA
- Frequency: 50/60 \pm 1 Hz
- Maximum power demand = 40 kVA @ 0.85 PF at a selected technique of 120 kV, 200 mA.
- Average (continuous) power demand at maximum duty cycle = 6.3 kVA.
- Idle power demand (without rotation and X-ray) = 2.6 kVA.

The A1 disconnect device referenced above must provide over-current protection for the system and have at least one Emergency Off switch within the scan suite, near the console. The preferred disconnect utilizes under voltage release control, rather than shunt trip devices. The rating of the A1 disconnect device depends on the nominal line voltage at the site. Refer to [12.3 Recommended Power Distribution System on page 88](#) for minimum rating requirements and suggested disconnect devices.



TO PREVENT POWER LOSS TO OTHER LOADS IN CASE OF AN UNEXPECTED CT OR PET SYSTEM FAULT, THE POWER FEEDER MUST HAVE OVERCURRENT PROTECTION SUCH THAT THE DOWN-STREAM OVERCURRENT PROTECTION DEVICES (E.G. GE A1 PANEL) CLEAR THE FAULT BEFORE ANY UP-STREAM OVERCURRENT PROTECTION DEVICE OPENS.

12.2.5 Regulation

Total load regulation, as measured at the PDU input terminals, must not exceed 6%. The capacity of the facility transformer and size and length of feeder wires directly affect the load regulation presented to the system. Refer to [12.3 Recommended Power Distribution System on page 88](#), for recommended single-unit installation specifics.

12.2.6 Phase Imbalance

The difference between the highest line-to-line voltage and lowest line-to-line voltage must not exceed 2% of the lowest line-to-line voltage.

12.2.7 Sags, Surges and Transients

Sags and surges of the power line must not exceed the absolute range limits shown in [Table 12-1 Nominal Line Voltage Ranges on page 89](#) Table 4 System Power Requirements. Limit maximum transient voltages to 1500 V peak.

12.2.8 Grounding

The customer's electrician needs to perform the following tasks:

- Bond metal conduit, raceway, or the armor of armored cable used to power the system to the PDU cabinet and to the PDU/PDA cabinet and the A1 Disconnect
- Run a dedicated 1/0 (55 mm²) or larger insulated copper ground wire from the main distribution panel to the PDU/PDA with the phase wires.
- Run the ground wire with the three-phase wires from the power source to the A1 Disconnect and from A1 Disconnect to the PDU/PDA. Grounding does not require a neutral wire.

NOTE

The shield or armor of armored cable ALONE does NOT provide sufficient grounding.

Bond the ground wire to the intermediate distribution panels through which it passes in accordance with local codes. The resistance between the PDU ground and the facility earth ground must not exceed 0.5 ohm. In addition, the total resistance between the PDU ground and earth must not exceed 2 ohms.

12.3 Recommended Power Distribution System

In all cases, qualified personnel must verify that the transformer and feeder (at the point of take-off) and the run to the CT system meet all the requirements stated in this document.

12.3.1 Using a Dedicated Distribution Transformer (Recommended)

The recommended power distribution system for a CT system is a dedicated feeder from the facility main isolation transformer. The minimum recommended transformer size for a dedicated distribution transformer provided for the system is 50 kVA, rated 2.4% regulation at unity power factor. [12.3.3 System Power Requirements on page 89](#) shows the minimum recommended feeder size and overcurrent protection device based on line voltage for this configuration.

12.3.2 Using an Existing Distribution Transformer

If it proves necessary to power the system from an existing distribution transformer and secondary feeder, such as the equipment distribution panel of an X-ray department, avoid installation with other X-ray equipment that uses rapid film changers. These changers use a large number of high-powered, closely-spaced exposures, which may coincide with the CT scan and produce image artifacts.

12.3.3 System Power Requirements

Be sure that the site can meet all of the minimum power requirements listed below before installing the system:

- Maximum power demand = 40kVA @ 0.85 PF: at a Selected Technique of 120 kV, 200 mA.
- Continuous (average) power demand at maximum duty cycle = 6.3 kVA.
- Maximum allowable total source regulation is 6%
- Minimum recommended transformer size OR secondary power: 50 kVA, with 2.4% rated regulation at unity power factor. Resultant maximum allowable feeder regulation is 3.6%.

Table 12-1 Nominal Line Voltage Ranges

Nominal line voltage MUST fall within ONE of these ranges.										
Average Power [VA]	6300	6300	6300	6300	6300	6300	6300	6300	6300	6300
Peak Power [VA]	40000	40000	40000	40000	40000	40000	40000	40000	40000	40000
Nominal Line Voltage [V]	200	220	240	380	400	415	420	440	460	480
Hi-Line Limit, +10% [V]	220	242	264	418	440	457	462	484	506	528
Lo-Line Limit, -10% [V]	180	198	216	342	360	374	378	396	414	432
Continuous Line Current [A]	18.2	16.6	15.2	9.6	9.1	8.7	8.7	8.3	7.9	7.6
Momentary Line Current [A]	115.5	105	96.3	60.8	57.8	55	55	52.5	50.2	48.2
Maximum Line Current [A]	128.3	116.7	107	67.6	64.2	61	61.1	58.4	55.8	53.5
Minimum Recommended Circuit Breaker [A]	115	115	115	75	75	70	70	70	60	60
Recommended A1 disconnect panel [A]	150	150	150	90	90	90	90	90	90	90

Table 12-2 Minimum Feeder Wire Size

Feeder Length (Power Substation to A1 Disconnect)	Minimum Feeder Wire Size, AWG or MCM (sq. mm) / VAC								
	200 VAC	220 VAC	240 VAC	380 VAC	400 VAC	415 VAC 420 VAC	440 VAC	460 VAC	480 VAC
15 m (50 ft)	3 (30)	3 (30)	3(30)	4 (22)	4 (22)	4 (22)	4 (22)	4 (22)	4 (22)
30 m (100 ft)	1/0 (55)	1 (45)	1 (45)	4 (22)	4 (22)	4 (22)	4 (22)	4 (22)	4 (22)
46 m (150 ft)	3/0 (85)	2/0 (70)	2/0 (70)	4 (22)	4 (22)	4 (22)	4 (22)	4 (22)	4 (22)
61 m (200 ft)	5/0 (125)	4/0 (100)	3/0 (85)	3 (30)	4 (22)	4 (22)	4 (22)	4 (22)	4 (22)
76 m (250 ft)	6/0 (170)	5/0 (125)	4/0 (100)	3 (30)	3 (30)	3 (30)	4 (22)	4 (22)	4 (22)

Continues on the next page

Table 12-2 Minimum Feeder Wire Size (Table continued)

Feeder Length (Power Substation to A1 Disconnect)	Minimum Feeder Wire Size, AWG or MCM (sq. mm) / VAC								
	200 VAC	220 VAC	240 VAC	380 VAC	400 VAC	415 VAC 420 VAC	440 VAC	460 VAC	480 VAC
91 m (300 ft)	6/0 (170)	5/0 (125)	5/0 (125)	1 (45)	2 (35)	3 (30)	3 (30)	3 (30)	3 (30)
107 m (350 ft)	7/0 (215)	6/0 (170)	5/0 (125)	1 (45)	1 (45)	2 (35)	2 (35)	3 (30)	3 (30)
122 m (400 ft)	7/0 (215)	6/0 (170)	6/0 (170)	1/0 (55)	1 (45)	1 (45)	1 (45)	1 (45)	3 (30)

Table 12-3 Minimum Sub-Feeder Wire Size

Sub-feeder Length (A1 to PDU/PDA)	Minimum Sub-feeder Wire, AWG or MCM (sq. mm)								
	200 VAC	220 VAC	240 VAC	380 VAC	400 VAC	415 VAC 420 VAC	440 VAC	460 VAC	480 VAC
9.7536 m (32 ft)	2 (35)	2 (35)	2 (35)	4 (22)	4 (22)	4 (22)	4 (22)	4 (22)	4 (22)

NOTE

In all cases the recommended ground wire is a 55 sq. mm (1/0) ground wire.

The information in [Table 12-1 Nominal Line Voltage Ranges on page 89](#), [Table 12-2 Minimum Feeder Wire Size on page 89](#), and [Table 12-3 Minimum Sub-Feeder Wire Size on page 90](#) assumes the use of copper wire, rated 75 C and run in steel conduit.

All amp capacity is determined in accordance with the National Electrical Code (NFPA 70), Table 310-16 (2002). The amp capacity of the circuit protection device listed above determines the minimum feeder size, except where total source regulation limits require a larger size.

NOTICE

Power feeders running under the scan room floor, as well as power vault substations under the floor, above the scan suite, or in adjacent rooms, may cause excessive EMI fields. The responsibility for meeting all site EMI requirements rests with the customer.

13 Interconnection Data

13.1 Introduction

The customer and the customer's electrical contractor should refer to the information in this section when establishing network and power interconnections for the system. Please note the following:

- [Figure 13-3 Interconnection Runs on page 96](#) shows interconnection runs for a 50/60 Hz system.
- [Table 13-1 Component Designators on page 91](#) shows component designators for supplied equipment and options and wall power outlets.
- [Table 13-4 Runs 1, 2, 3, 4 and 5 Connections on page 95](#) lists customer-installed wiring and supplied cables. The actual length of each run is less than the length of supplied cables to allow for routing inside the equipment. Cable diameters and sizes of connectors are provided to aid in sizing conduit and access plates.
- [13.3.1 GE Supplied \(Standard, Short Length 5490840\) \(Reference IEC 60601-1-2 6.8.3.201\) on page 92](#) lists details for connection to the system and GE approved accessories using standard (short) length and non-standard (long) length cables, respectively. Details appear for the following types of runs, when appropriate:
 - Flush-floor duct
 - Computer floor
 - Through-wall bushing
 - Junction box
 - Surface floor duct
 - Through-floor duct
 - Wall duct
 - Conduit
- To minimize the need for additional junction boxes, use either a cable raceway system or a raised computer floor. This system uses prefabricated cables with large plugs. Therefore, try to avoid conduit or pipe for cable runs.

13.2 Component Designators

Table 13-1 Component Designators

DESIGNATOR	APPLIES TO	SOURCE
A1	Primary power disconnect	Contractor supplied
MDP	Main distribution panel	Contractor supplied
CT1	Patient table	System
CT2	Gantry	System
OC1	console/computer	System
PDU	Power Distribution Unit	System
SEO	System emergency off	Contractor supplied
WL	"X-ray on" warning light	Contractor supplied
DS	Door Interlock Switch	Contractor supplied
BBNC	Broad-band network connection	Contractor supplied

13.3 Interconnect Runs, Wiring and Cables

13.3.1 GE Supplied (Standard, Short Length 5490840) (Reference IEC 60601-1-2 6.8.3.201)

Table 13-2 GE Supplied Cables (Standard Run, Short) - UL Information

Run #	Length, Actual (Usable)		Part #	Description	UL Cable Information								Pull Size mm (Inches)
	ft	m			UL Style	Flam. Rating	Voltage Rating	Voltage Actual	Temp. Rating (C)	Dia. mm (inch)	# of Cond	Size AWG	
50A	28 (20)	8.5 (6.1)	2343529-3	HVDC, from PDU to Gantry	2587	FT4	600	350VDC	90	19 (0.75)	3	(2) 4 (1) 8	22 (0.87) Dia.
51A	28 (20)	8.5 (6.1)	2343530-3	Axial Driver Power, PDU to Gantry	2587	FT4	600	440Y/254	90	15 (0.59)	4	14	11 (0.44) Dia.
52A	28 (20)	8.5 (6.1)	5645040	Power supply cable from PDU to Gantry	2587	FT4	600	208Y/120	90	14 (0.55)	5	8	56.4 (2.22) Dia.
53A	49.2 (44.2)	15 (13.5)	5645031-2	Power supply cable from PDU to Console	2587	FT4	600	120VAC	90	12 (0.47)	3	10	56.4 (2.22) Dia.
55A	28 (20)	8.5 (5.97)	2371450-2	Ground, PDU to raceway	1284	VW-1 FT-1	600	0	105	16 (0.63)	1	1/0	16 (0.63) Dia.
56A	49.2 (41)	15 (12.5)	5441518-3	Ground, Raceway to console	1283	VW-1 FT-1	600	0	105	12 (0.47)	1	2	12 (0.47) Dia.
100A	32.5 (20)	9.9 (6.1)	5120646-4	Signal, Gantry TGPSV J11 to PDU		FT-4	300	<30VDC	80	12.5 (0.49)	25	22	17 x 58 (0.68 x 2.30)
101A	49.2 (37.7)	15 (11.5)	5645006-2	From Console RL, TGPSV J9 to OC		FT-4	300	<30VDC	80	12.5 (0.49)	25	22	17 x 58 (0.68 x 2.30)

Continues on the next page

Table 13-2 GE Supplied Cables (Standard Run, Short) - UL Information (Table continued)

Run #	Length, Actual (Usable)		Part #	Description	UL Cable Information								Pull Size mm (Inches)
	ft	m			UL Style	Flam. Rating	Voltage Rating	Voltage Actual	Temp. Rating (C)	Dia. mm (inch)	# of Cond	Size AWG	
102 A	49.2 (42.7)	15 (13)	5645022-2 / 5645021-2	LAN cable from Gantry to OC			1900	<30VD C		5.9 (0.234)	8	24	15 (0.59) Dia.

Figure 13-1 System Interconnect Diagram of Short Cables (Standard)-For Host PC's - Z420/Z440/Z4G4

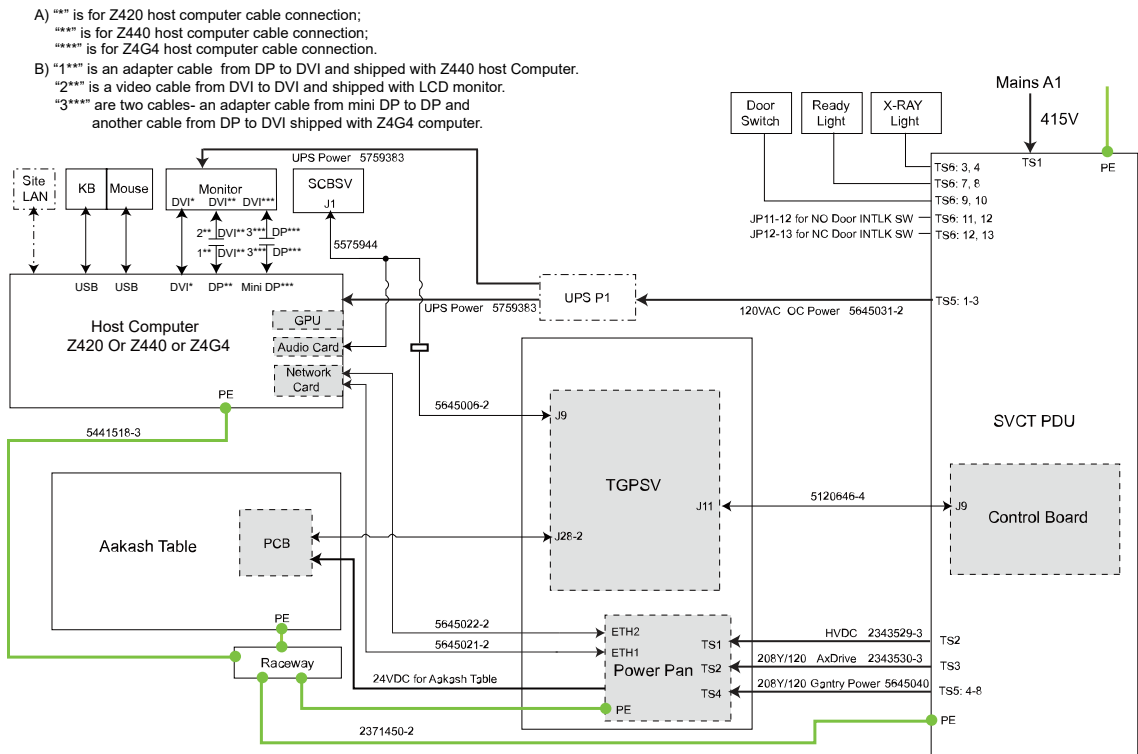
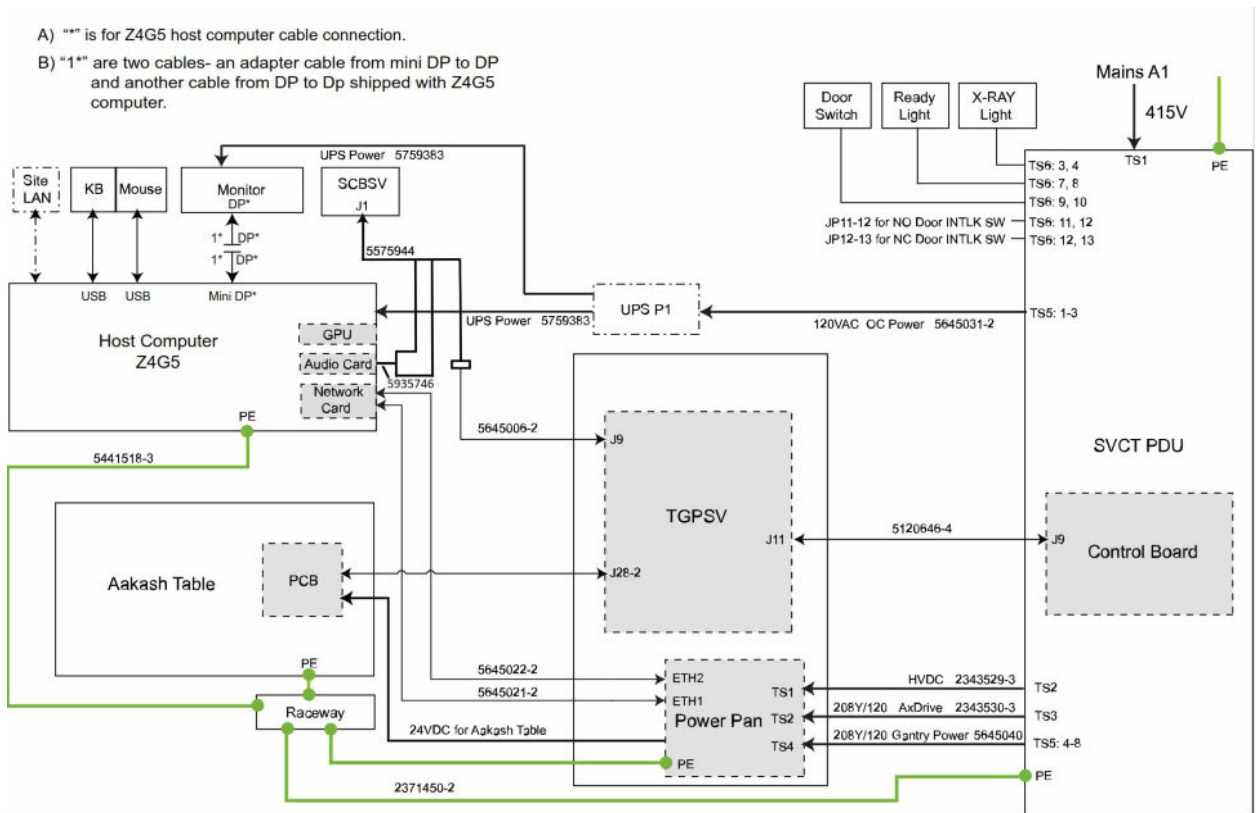

Figure 13-2 System Interconnect Diagram of Short Cables (Standard)- For Host PC Z4G5



13.3.2 GE Supplied (Console Cables)

Table 13-3 GE Supplied Console Cables

PART #	DESCRIPTION	CONNECT TO	QUANTITY	LENGTH	
				mm	inch
5575994	SVCT SCB Cable	SCBSV	1.0	2000	78.74
5645031-2	Power Cable for Scan Monitor (Short Cable)	Monitor	1.0	16500	649.61

13.3.3 Contractor/Customer-Supplied

Table 13-4 Runs 1, 2, 3, 4 and 5 Connections

Customer Installed Wiring		Description	Cables Supplied			Plug Pulling Dimensions		Wire and Cable Pig-tails ft. (M.)	
Qty	Size AWG -Kcmil		Part No	LENGTH ft. (M.)	DIA. in (mm)	From	TO	From	To
RUN NO. 1 FROM PRIMARY POWER SOURCE TO FACILITY DISCONNECT (POWER SOURCE - A1/MDP)									
 NOTE The primary power ground to the A1/MDP disconnect must meet local codes, in all cases the recommended ground wire is a 1/0 (50 mm ²) ground wire.									
Maximum Run Length *									
3	*	POWER						3 (1)	3(1)
1	1/0 (50)	GROUND						3 (1)	3 (1)
RUN NO. 2 FROM FACILITY DISCONNECT TO POWER DISTRIBUTION UNIT (A1/MDP - PM)									
3	*	POWER						3 (1)	3(1)
1	1/0 (50)	GROUND						3 (1)	3 (1)
-	-	NEUTRAL -- Not Re-quired						3 (1)	3 (1)
RUN NO. 3 FROM FACILITY DISCONNECT TO SYSTEM EMERGENCY OFF (A1/MDP - SEO)									
2	14 (2.5)	POWER						6 (2)	6 (2)
1	14 (2.5)	GROUND						6 (2)	6 (2)
RUN NO. 4 POWER DISTRIBUTION UNIT TO WARNING LIGHT CONTROL (PDU - WL)									
2	14 (2.5)	WARNING LIGHT 240V AC CONTROL TS6 1, 2, 3, 4, 5, 6, 7, 8							
RUN NO. 5 POWER DISTRIBUTION UNIT TO SCAN ROOM DOOR INTERLOCK (PDU - DOOR SWITCH)									
2	14 (2.5)	SCAN ROOM DOOR INTER LOCK TS6 9, 10							
*	REFER TO Table 12-3 on page 102Table 3 FOR AWG (MM2) WIRE SIZES								
RUN NO. n/a BBNC									

Continues on the next page

Table 13-4 Runs 1, 2, 3, 4 and 5 Connections (Table continued)

Customer Installed Wiring		Description	Cables Supplied			Plug Pulling Dimensions		Wire and Cable Pig-tails ft. (M.)	
Qty	Size AWG -Kcmil		Part No	LENGTH ft. (M.)	DIA. in (mm)	From	TO	From	To
1	customer determined	Hospital Broadband Network Connection (Wall Jack: Placed on the wall behind the console.)							

Figure 13-3 Interconnection Runs

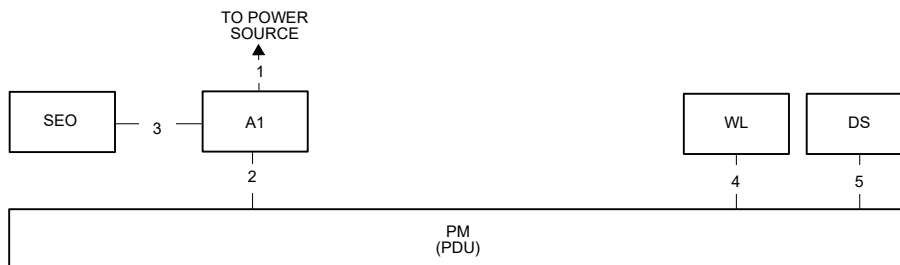

NOTES:

- Used for remote diagnostics - Option
- Refer to the appropriate Pre-installation / Installation documents for the Laser Camera
- Category 5 cable. Use one of the following patch cords:

CAT Num	GE Part Num	Length
K9000WB	2215028-10	20 m
K9000KP	2215028-5	10 m
K9000JR	2215028-4	5 m
K9000WA	2215028-9	3 m
- In order to avoid any violation of each National Regulation (NEC in USA, CCC in China, etc.), use of the compliant cable/wire is recommended. For China market, China end-user shall purchase the power supply cable that has the CCC mark.

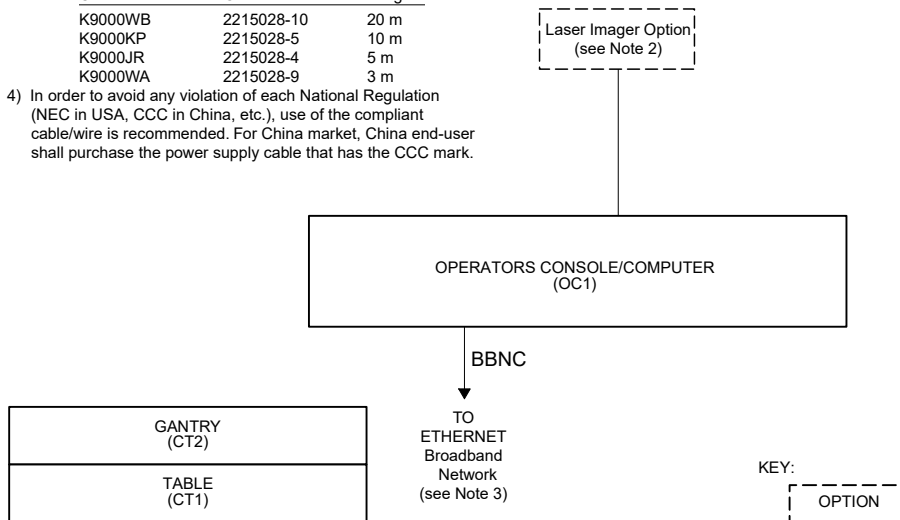

13.3.4 Fuse

Table 13-5 Fuse

Item	number	qty	fru code	description/name
1	46-231S16P1	1.0	Yes	FUSE, FAST, 5X20MM, IA, 2SOV, 35A INTERRUPT, UL REC
2	5336242	3.0	Yes	Fuse for brake resistor
3	5435503	2.0	Yes	fuse 10A 250V AC
4	5665672	1.0	Yes	FUSE, TIME DELAY, 6.3X32MM, 20A, 250V, 400A INTERRUPT AT 250VAC,
5	5336240	1.0	Yes	Fuse for drive's control power
6	5184715-2	1.0	Yes	FUSE, TIME DELAY, 5X20MM, 2A IEC, 250V, 1.5KA INTERRUPT, CERAMIC, UL REC
7	5324766	1.0	Yes	100A FUSE
8	5456093	1.0	Yes	FUSE - 700 V, 100 A, FAST SEMI
9	46-170021P50	1.0	Yes	FUSE, TIME DELAY, 6.3X32MM, 12A, 250V, 400A INTERRUPT AT 250VAC, CERAMIC, UL

13.4 Contractor Supplied Components

Table 13-6 Contractor-Supplied Components

REFERENCE	ASSOCIATED EQUIPMENT	MATERIAL/LABOR SUPPLIED BY CUSTOMER CONTRACTOR	USA VENDOR / CAT NO. GE CATALOG
A1/MDP 380/415/480 V 50/60 Hz	Fusible Disconnect and Magnetic Contactor	3 Pole, 380/415/480 V, Combination breaker with magnetic contactor. Includes control transformer, optional UPS interface, On/Off controls and auto-restart feature.	Recommend* ¹ : <ul style="list-style-type: none"> E45021BA (80A) E4502AB/E4502BB (90A)
BBNC (required)	Broad-Band Network Connection	Broad-Band network connection wall jack, located within 1m (39inches) of Operator Console location, for internal hospital networking and InSite Broad-Band connectivity. Cabling to conform to facility's IT standards.	
	System Components	Reference the system installation drawings supplied by Installation Support Services within your geographic area.	
* ¹ *Refer to 13.3.3 Contractor/Customer-Supplied on page 95			

13.5 Scan Room Warning Light and Door Interlock



NOTE

For door interlock connection, please select the proper jumper setting according to field door interlock (normal open or normal close).

If jumper is not in place, exposures will not be made. Check this jumper if you get scan interlock errors.

Figure 13-4 TS6 X-Ray Warning Light and Room Door Interlock Connections

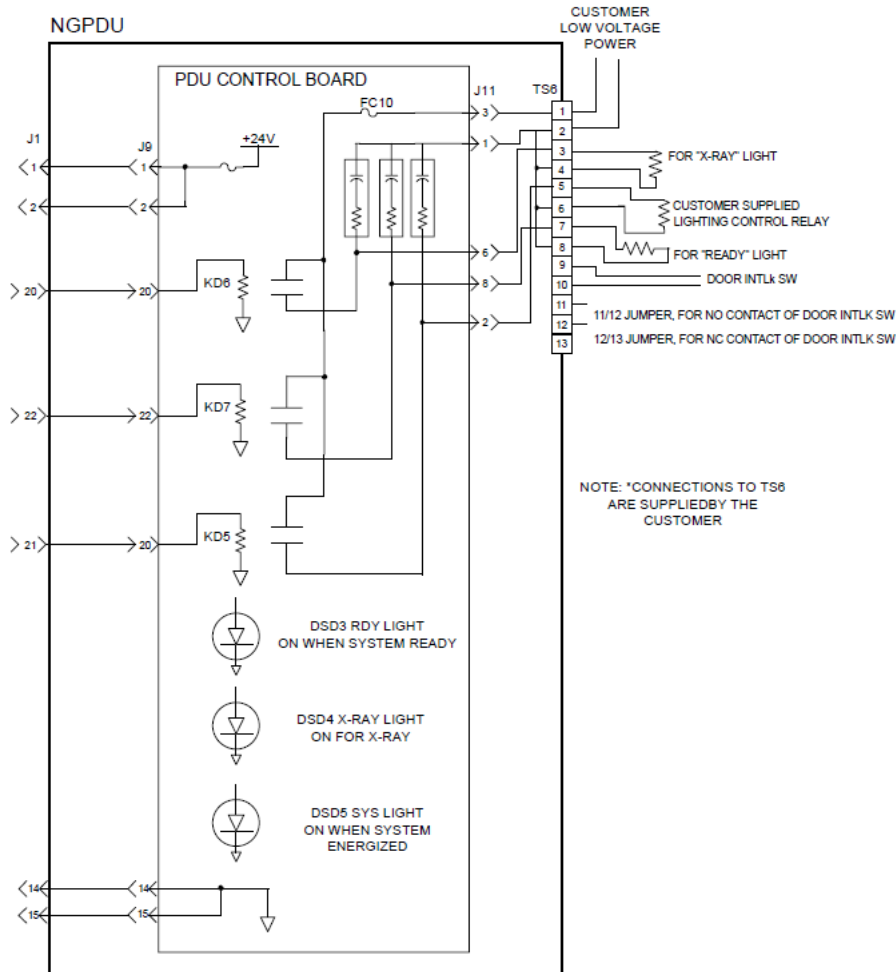

14 Delivery and Storage Requirements

This chapter provides information necessary for planning a safe and successful delivery of the system from GE HealthCare to the receiving area of the installation site, and from the receiving area of that facility to the scan suite.

14.1 Delivery Types and System Lifting and Rigging Restriction



DANGER

PERSONAL INJURY OR DEATH, EQUIPMENT DAMAGE. TIP HAZARD.

GANTRY IS VERY HEAVY AND MAY TIP OVER IF TILTED PAST 10 DEGREES.

WHEN TRANSPORTING A SYSTEM TO THE FINAL DESTINATION, DO NOT EXCEED TILT ANGLE EQUAL TO, OR GREATER THAN 10 DEGREES IN EITHER DIRECTION OF AXIS.



NOTE

The system shall never be lifted by the dollies.

Your Project Manager of Installation will determine the most appropriate means of transporting the system to your facility. However, the type of receiving area at the facility where the installation will occur determines, to a large extent, the method used to transport the system to that facility. When planning for delivery, facilities fall into two general categories: those with a loading dock, and those without a loading dock.

14.1.1 Loading Dock Deliveries

Facilities with a loading dock in their receiving area can generally accommodate delivery of the system by van. This is the preferred method of transporting the system to the installation site, as dock-to-dock shipment by van minimizes the possibility of dropping the gantry. Also, packing the CT system for van shipment involves minimum tear-down of components. This system is shipped Lean packed on pallets and dollies with approximately 10 units.

14.1.2 Ground (Non-Loading Dock) Deliveries

Facilities without a loading dock usually require ground delivery by either liftgate or appropriately sized forklift. Such deliveries require unloading the system components from the truck and then rolling them across smooth sidewalks or other paved surfaces into the facility.

14.1.2.1 Liftgate Truck

Delivery of the system by liftgate truck requires an appropriate capacity truck with a liftgate capable of lifting 3 tons. If using a rollback truck, the Project Manager of Installation should be on-site at the time of delivery to supervise this operation in person.

14.1.2.2 Tiltbed Truck - NOT Approved

Delivery of the system by tilt-bed truck is no longer an approved delivery method due to EHS safety risks of tipping the system over. If a loading dock is not available, then a Fork-lift truck shall instead be used.

14.1.2.3 Forklift Truck

**NOTE**

The tines on the fork truck need to be a minimum of 8' long in order to pick the gantry on the lifting skid past the center point of gravity.

A forklift can be used to unload the gantry, provided that the lifting option is ordered and delivered. The system will arrive with a lifting skid attached to the gantry and table. This option cannot be added later as an on-site addition.

14.1.2.4 Rigging

The CT gantry assemblies shall not be lifted by their dollies. The CT gantry assemblies shall not be transported across any surface by any means other than the dollies provided by GE HealthCare. The CT gantry assemblies have no lifting points on them and are not designed to be lifted by any special rigging attached to the gantry assemblies themselves.



POSSIBLE SEVERE PERSONAL INJURY OR DEATH.

THE DOLLIES ARE NOT DESIGNED TO BE USED AS AN ATTACHMENT POINT FOR ANY METHOD OF LIFTING THE SUBSYSTEMS.

ATTACHING LIFTING STRAPS, CABLES OR MECHANISMS TO THE DOLLY HANDLES OR ANY OTHER PART OF THE DOLLY IS STRICTLY PROHIBITED.

NOTICE

If it is determined that the subsystems must be lifted by crane or other lifting method the PM or person responsible for local siting of the system shall NOT proceed with the installation without consulting directly with GE HealthCare Engineering.

Lifting the subsystems by crane or other lifting method should always be avoided. All alternate methods of delivery should be evaluated including the removal of any obstructions, doorways, walls, and windows.

If lifting is still required:

1. The entire gantry assembly and both gantry transport side dollies must be placed on a lifting platform. GE HealthCare does not provide a lifting platform. The Stationary Assembly shall be lowered to its transport position with the gantry base in contact with the platform. The Rotating Assembly shall be lowered to its transport position resting on the dolly transport pads in contact with the platform.

**NOTE**

If the platform has limited space, the gantry transport side dollies may be removed during the lift. Once the lift is completed, the gantry transport side dollies must be installed back on the gantry assembly.

2. The entire patient table must be on its dollies and lifted while sitting on a lifting platform. The patient table on its dolly shall be lowered to its transport position so the table base is in contact with the platform.
3. The platform must be designed so no lifting straps or cables come in contact with any part of the gantry or table subsystems or its side dollies.
4. The lifting platform shall bear the entire load. No part of the subsystem shall bear any load during the lift.

NOTE

If delivery requires vertical or horizontal lifting, the PM needs to add the necessary identifier to the order.

14.2 Delivery to the Scan Suite

Once at the installation site, conveyance of the system into the scan suite may involve special considerations, such as vertical lifting, or transportation through stairwells, which involves additional planning by the Project Manager of Installation.

14.2.1 Lifting

Both vertical and horizontal lifting require professional riggers.

If delivery requires horizontal lifting, the PMI should contact with CT engineering team with installation concession.

If delivery requires vertical lifting and deviates from the requirement outlined in the PIM then engineering must be contacted for approval.

14.2.1.1 Stairway Deliveries

Stairways with angles at or less than 45 degrees can accommodate delivery of system components. If the site requires delivery through stairwells, the PMI adds the appropriate identifier to the order to ensure proper packaging of the system, and notifies CT engineering before attempting the procedure. The components ship attached to special lifting skids with lifting instruction for riggers.

14.2.2 Floor Protection

GE recommends floor protection along the delivery path from the dock/receiving area to scan room.

14.2.3 Un-loading and un-packing the System

Retain the packaging surrounding the following components:

- Console-Shipped on a shock resistant skid. Do not remove the skid.
- UPS-Shipped on a shock resistant skid. Do not remove the skid.

14.3 Gantry Delivery Considerations

14.3.1 Gantry Shipping State

The gantry ships with most covers installed, and the assembly mounted between two dollies (see [Figure 14-2 Gantry with Front and Rear Covers \(default shipping status\) on page 103](#)). Use the dolly elevating casters to lift the gantry off its base and roll it into position.

Figure 14-1 Gantry with Shipping Dollies

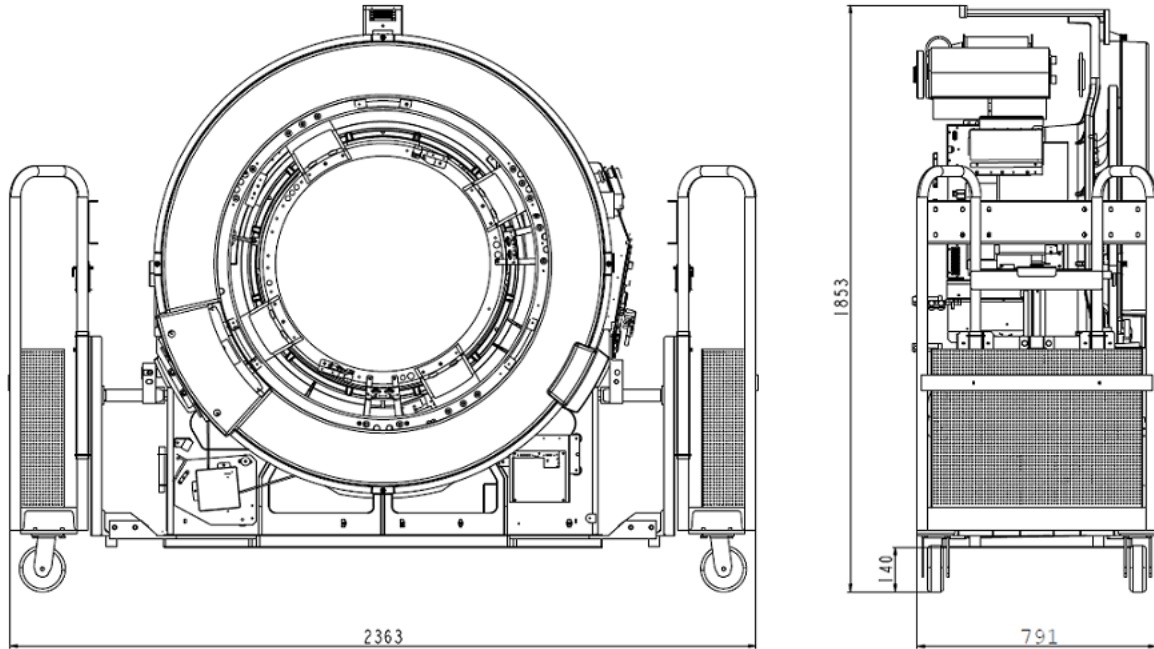
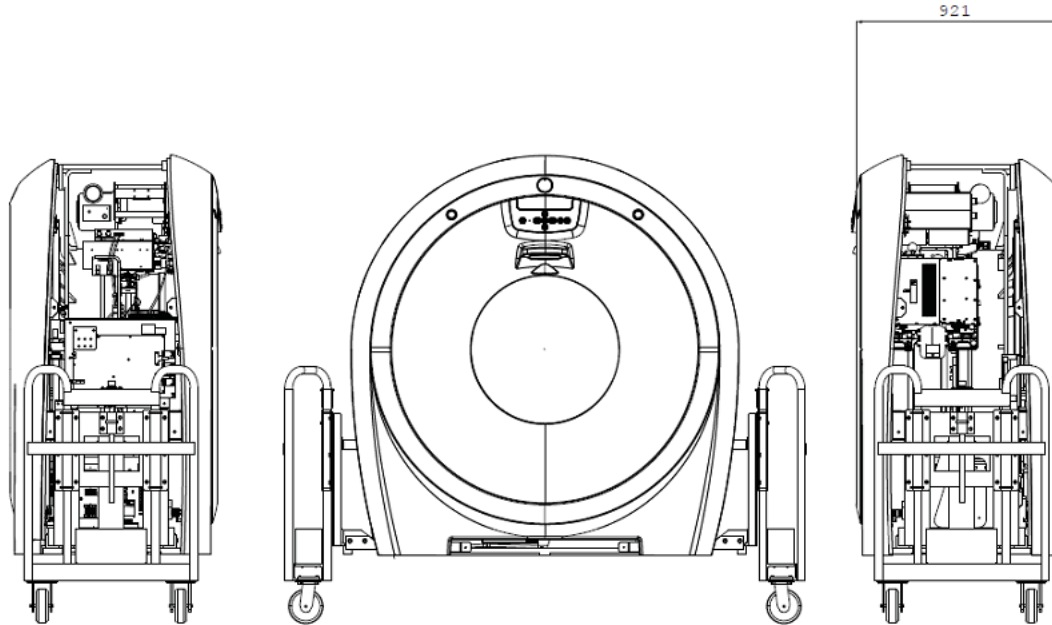

Figure 14-2 Gantry with Front and Rear Covers (default shipping status)



14.3.2 Door Openings

Unobstructed door openings, for moving equipment into the building, must measure 850 mm X 1900 mm (33.5 in. X 74.8 in.) minimum. Corridors with a width of 2300 mm (7.5 ft.) also prove helpful.

14.3.3 Elevator Requirements

When moving the gantry from the receiving location to the scanning room, pay special attention to elevator size and capacity. Removing side rails and one dolly after placing the gantry in the elevator reduces the gantry width/length and elevator depth requirements.

Due to gantry component weight differences all weights listed below are averages. This change can measure ±18.14 kg (±40 lb). Contact the elevator manufacturer if the gantry weight exceeds elevator capacity (see [Table 14-1 Size of Gantry & Dollies, with and without Side Rails on page 103](#)).

Table 14-1 Size of Gantry & Dollies, with and without Side Rails

Configuration	Length	Width	Height	Weight
Dollies On	2363 mm (93.1 in.)	757 mm (without Covers) (29.8 in.) 921 mm (with Covers) (36.2 in.)	1853 mm (73 in.)	1060 kg (2337 lb)
Dollies Off, Covers Off	1543 mm (60.8 in.)	757 mm (29.8 in.)	1713 mm (67.5 in.)	860 kg (1896 lb)

The minimum hallway and door size for a gantry with covers and dollies attached but side rails removed, is 1016 mm (40 in.). For alternative lifting arrangements and instructions, contact GE Installation Support Services.

14.4 Table Delivery Considerations

Table Delivery Considerations

The whole Aakash table is shipped in one box.

For the table dimensions, refer to [Table 14-2 Table Dimensions with dollies on page 104](#).

Table 14-2 Table Dimensions with dollies

	Length		Width		Height		Weight	
	mm	in	mm	in	mm	in	kg	lb
Aakash Table	2098	82.6	583	23	855	33.7	150	332

14.5 Console Delivery Considerations

The dimensions of the console alone (as shipped) measure:

- Z420: 445 mm (17.53 in.) deep, 178 mm (7.00 in.) wide, and 448 mm (17.62 in.) high.
- Z440: 556 mm (21.9 in) deep, 315 mm (12.4 in) wide, and 615 mm (24.2 in) high.
- Z4G4: 560 mm (22.0 in) deep, 310 mm (12.2 in) wide, and 560 mm (22.0 in) high.
- Z4G5: 563mm (22.2 in) deep, 310mm (12.2in) wide and 565mm (22.2 in) high.

14.6 Storage Requirements

NOTICE

Failure to adhere to storage requirements can result in equipment damage.

14.6.1 Short-term Storage (Less than Six Months)

If storing the CT system before installation for less than six months, store it in a temperature- and humidity-controlled warehouse. Protect it from weather, dirt, and dust. Meeting the following requirements prevents rust and corrosion from forming on bearing surfaces due to condensation:

- Storage temperature should not exceed 0° to 30° C (32° to 86° F).
- Maintain relative humidity (non-condensing) up to 70%.
- Maximum rate of relative humidity change measures 5%/hr.
- Maximum rate of temperature change measures 3° C/hr. (5° F/hr.)
- Storage longer than 6 months is not recommended.

NOTICE

Between delivery qualifies as short-term storage. Van storage must meet the same specifications listed above.

14.6.2 Construction-Site Storage

When storing the CT system at a construction site be sure to adhere to the following storage requirements:

- Do not damage or puncture the shipping crate.
- Do not remove packaging until all construction is completed at the site and all dust created by the construction is removed.
- Maintain a storage temperature within the range of 10° to 32° C (50° to 90° F).
- Maintain a relative humidity (non-condensing) between 20% and 70%.

14.7 Extreme Temperature Delivery and Storage

CAUTION



Failure to adhere to extreme temperature requirements during delivery and storage can result in equipment damage.

Avoid extreme temperatures during system transportation and delivery.

Extreme temperatures consist of temperatures below -18° C (0° F), or above 49° C (120° F), without humidity control.

When transporting the CT system, prevent extended exposure of the system to temperatures or humidity outside of the following specifications:

- Up to two weeks duration
- Temperature: -40° to +70° C (-40° to +158° F)
- Humidity: 10% to 100%, including condensing
- Altitude: -549m to 5,486m (-1,800 ft. to 18,000 ft.)

NOTICE

Component freezing occurs when exposing the CT system to temperatures below -18° C (0° F) for a period longer than two (2) days. Allow a minimum of 12 hours for the CT system to adjust to ambient room temperature prior to installation.

15 Handling Requirements

Communicate the information in this chapter to any personnel who will transport, move, or otherwise handle the system components during transportation and delivery of the system.

15.1 Transportation

To avoid dropping the gantry, it is recommended that the system is transported from GE to the facility of the installation site, shipping dock-to-dock in a van. However, facilities without a loading dock may transport the system using liftgate or flatbed trucks, provided that no dropping or mis-handling of the system occurs. These methods involve unloading system components from the truck and then rolling them across SMOOTH sidewalks or other paved surfaces.

15.2 Handling Requirements

The design of the system does not tolerate dropping, shock, vibration, tipping, or hoisting. Be sure to communicate these handling requirements to all parties involved in transporting, moving, and handling system components.

15.2.1 Avoid Dropping

Never drop the gantry, console, table, or PDU. A drop from a height greater than 13 mm (0.5 in.) may cause structural damage to the frame or other major components. Damage resulting from a drop (e.g., bent frame, misalignment) may not become apparent until after the system is installed.

15.2.2 Avoid Shocks and Vibrations

The design of the system, including the gantry, console, table, and PDU, does not tolerate excessive shock or vibration, which may occur during unloading. For example, rolling the console across a "washboard" style ramp may vibrate components, causing loose or broken connections. Damage resulting from shock or vibration (e.g., monitor, CD-ROM, hard-drive, or console failure) may not become evident until after the system is installed.

15.2.3 Avoid Tipping

All system components must remain upright at all times; avoid tipping them. Move the gantry by rolling it on its dollies ONLY, do NOT hoist it. Avoid tipping or lifting the gantry when moving it through hallways, doorways, elevators, etc.

NOTICE

Lifting the gantry requires engineering approval for each occurrence. Your GE PMI should contact CT Engineering for all special lifting requirements, as unauthorized gantry lifting can cause gantry bearing damage.



GE HealthCare

www.gehealthcare.com