



GE HealthCare

3.0T AR Series Magnets

Magnet Handling Manual

5869669-1EN
Revision 7
US English

Language Policy

DOC0371395 - Global Language Procedure

ПРЕДУПРЕЖ ДЕНИЕ (BG)	Това ръководство е налично само на китайски (ZH-CN), английски, френски, немски, японски, корейски, полски, португалски (PT-BR), руски, испански и виетнамски. Ако доставчикът на услуги на даден клиент изисква език, който е различен от тези езици, отговорност на клиента е да предостави преводачески услуги.
警告 (ZH-CN)	本手册仅提供中文 (ZH-CN)、英文、法语、德语、意大利语、日语、韩语、波兰语、葡萄牙语 (PT-BR)、俄语、西班牙语和越南语版本。如果客户的服务提供商需要其他语言，则客户有责任提供翻译服务。
警告 (ZH-HK)	本手冊僅提供中文 (ZH-CN)、英文、法文、德文、意大利文、日文、韓文、波蘭文、葡萄牙文 (PT-BR)、俄文、西班牙文及越南文版本。如客戶的服務供應商需要這些語言以外的版本，則相關客戶有責任提供有關的翻譯服務。
警告 (ZH-TW)	此手冊僅提供中文 (ZH-CN)、英文、法文、德文、義大利文、日文、韓文、波蘭文、葡萄牙文 (PT-BR)、俄文、西班牙文和越南文版本。假如客戶的服務提供者所需語言版本不在所列語言之中，客戶需自行負責提供翻譯服務。
UPOZORENJE (HR)	Ovaj je priručnik dostupan samo na kineskom (ZH-CN), engleskom, francuskom, njemačkom, talijanskom, japanskom, korejskom, poljskom, portugalskom (PT-BR), ruskom, španjolskom i vijetnamskom jeziku. Ako klijentov serviser zahtijeva jezik koji nije jedan od tih jezika, odgovornost je klijenta pružiti uslugu prevođenja.
VÝSTRAHA (CS)	Tato příručka je k dispozici pouze v čínštině (ZH-CN), angličtině, francouzštině, němčině, italštině, japonštině, korejštině, polštině, portugalštině (PT-BR), ruštině, španělštině a vietnamštině. Pokud poskytovatel služeb zákazníka vyžaduje jiný jazyk než tyto jazyky, je odpovědností zákazníka poskytovat překladatelské služby.
ADVARSEL (DA)	Denne vejledning findes kun på kinesisk (ZH-CN), engelsk, fransk, tysk, italiensk, japansk, koreansk, polsk, portugisisk (PT-BR), russisk, spansk og vietnamesisk. Hvis en kundes tjenesteudbyder kræver et andet sprog end disse sprog, er det kundens ansvar at levere oversættelsestjenester.
WAARSCHUWING (NL)	Deze handleiding is alleen beschikbaar in het Chinees (ZH-CN), Engels, Frans, Duits, Italiaans, Japans, Koreaans, Pools, Portugees (PT-BR), Russisch, Spaans en Vietnamees. Als de serviceprovider van een klant een andere taal dan deze talen vereist, is het de verantwoordelijkheid van de klant om vertaalservices te leveren.
WARNING (EN)	This manual is available in Chinese (ZH-CN), English, French, German, Italian, Japanese, Korean, Polish, Portuguese (PT-BR), Russian, Spanish, and Vietnamese only. If a customer's service provider requires a language other than these languages, it is the customer's responsibility to provide translation services.
HOIATUS (ET)	See juhend on saadaval ainult hiina (ZH-CN), inglise, prantsuse, saksa, itaalia, jaapani, korea, poola, portugali (PT-BR), vene, hispaania ja vietnami keeles. Kui kliendi teenusepakkujal on vaja juhendit mõnes muus keeles, on tõlketeenuste osutamine kliendi kohustus.
VAROITUS (FI)	Tämä opas on saatavilla vain kiinaksi (ZH-CN), englanniksi, ranskaksi, saksaksi, italiaksi, japaniksi, koreaksi, puolaksi, portugaliksi (PT-BR), venäjäksi, espanjaksi ja vietnamiksi. Jos asiakkaan palveluntarjoaja edellyttää muuta kuin näitä kieliä, käänöspalveluiden tarjoaminen on asiakkaan vastuulla.
ATTENTION (FR)	Ce manuel est disponible uniquement en allemand, anglais, chinois (ZH-CN), coréen, espagnol, français, italien, japonais, polonais, portugais (PT-BR), russe et vietnamien. Si le prestataire de services d'un client nécessite que le manuel soit rédigé dans une autre langue que celles mentionnées ci-dessus, il incombe au client de le faire traduire.
WARNUNG (DE)	Dieses Handbuch ist nur auf Chinesisch (ZH-CN), Englisch, Französisch, Deutsch, Italienisch, Japanisch, Koreanisch, Polnisch, Portugiesisch (PT-BR), Russisch, Spanisch und Vietnamesisch verfügbar. Wenn ein Dienstleister des Kunden dieses in einer anderen Sprache als die genannten benötigt, liegt es in der Verantwortung des Kunden, Übersetzungsdienstleistungen zu erbringen.

ΠΡΟΕΙΔΟΠΟΙΗΣΗ (EL)	Αυτό το εγχειρίδιο είναι διαθέσιμο μόνο σε Κινεζικά (ZH-CN), Αγγλικά, Γαλλικά, Γερμανικά, Ιταλικά, Ιαπωνικά, Κορεατικά, Πολωνικά, Πορτογαλικά (PT-BR), Ρωσικά, Ισπανικά και Βιετναμέζικα. Εάν ο πάροχος υπηρεσιών ενός πελάτη απαιτεί γλώσσα που δεν συμπεριλαμβάνεται σε αυτές τις γλώσσες, αποτελεί ευθύνη του πελάτη να παρέχει υπηρεσίες μετάφρασης.
FIGYELMEZTETÉS (HU)	Ez a kézikönyv az alábbi nyelveken érhető el: angol, francia, japán, kínai (ZH-CN), koreai, lengyel, német, olasz, orosz, portugál (PT-BR), spanyol és vietnámi. Ha az ügyfél szolgáltatója ezektől eltérő nyelvű kézikönyvet szeretne, akkor az ügyfél feladata, hogy gondoskodik a megfelelő fordításról.
AÐVÖRUN (IS)	Þessi handbók er aðeins fánleg á kínversku (ZH-CN), ensku, frönsku, þýsku, ítölsku, japönsku, kóresku, pólsku, portúgölsku (PT-BR), rússnesku, spænsku og víetnömsku. Ef þjónustuaðili viðskiptavinar þarfnast annars tungumáls en þessara tungumála er það á ábyrgð viðskiptavinarins að veita þýðingarþjónustu.
AVVERTENZA (IT)	Questo manuale è disponibile solo in lingua cinese (ZH-CN), inglese, francese, tedesco, italiano, giapponese, coreano, polacco, portoghese (PT-BR), russo, spagnolo e vietnamita. Qualora un fornitore di servizi del cliente richieda una lingua diversa dall'inglese, sarà responsabilità del cliente fornire il servizio di traduzione corrispondente.
警告 (JA)	このマニュアルは、中国語 (ZH-CN)、英語、フランス語、ドイツ語、イタリア語、日本語、韓国語、ポーランド語、ポルトガル語 (PT-BR)、ロシア語、スペイン語、およびベトナム語のみで提供されています。お客様のサービスプロバイダがこれらの言語以外の言語を必要とする場合は、お客様の責任において翻訳サービスを提供してください。
경고 (KO)	이 설명서는 중국어(중국어-중국), 영어, 프랑스어, 독일어, 이탈리아어, 일본어, 한국어, 폴란드어, 포르투갈어(포르투갈어-브라질), 러시아어, 스페인어, 베트남어로만 제공됩니다. 고객의 서비스 제공자가 이 언어를 제외한 다른 언어를 요구하는 경우, 번역 서비스를 제공하는 것은 고객의 책임입니다.
BRĪDINĀJUMS (LV)	Šī rokasgrāmata ir pieejama tikai ķīniešu (ZH-CN), angļu, franču, vācu, itāliešu, japāņu, korejiešu, poļu, portugāļu (PT-BR), krievu, spāņu un vjetnamiešu valodā. Ja klientu apkalpošanas speciālistam ir nepieciešama cita valoda, kas atšķiras no šeit norādītajām, klienta pienākums ir nodrošināt tulkotājas pakalpojumu.
ĮSPĖJIMAS (LT)	Šis vadovas pateikiamas tik kinų (ZH-CN), anglų, prancūzų, vokiečių, italų, japonų, korėjiečių, lenkų, portugalų (PT-BR), rusų, ispanų ir vietnamiečių kalbomis. Jei klientų paslaugų teikėjui reikalinga kita nei šios kalba, už vertimo paslaugų suteikimą atsako klientas.
ADVARSEL (NO)	Denne håndboken er bare tilgjengelig på kinesisk (ZH-CN), engelsk, fransk, tysk, italiensk, japansk, koreansk, polsk, portugisisk (PT-BR), russisk, spansk og vietnamesisk. Hvis en kundes tjenesteleverandør krever et annet språk, er det kundens ansvar å levere en oversettelsestjeneste.
OSTRZEŻENIE (PL)	Niniejsza instrukcja jest dostępna wyłącznie w języku chińskim (ZH-CN), angielskim, francuskim, niemieckim, włoskim, japońskim, koreańskim, polskim, portugalskim (PT-BR), rosyjskim, hiszpańskim i wietnamskim. Jeśli usługodawca klienta wymaga języka, który nie został wymieniony powyżej, obowiązkiem klienta jest zapewnienie usług tłumaczeniowych.
ATENÇÃO (PT-BR)	Este manual está disponível somente em chinês (ZH-CN), inglês, francês, alemão, italiano, japonês, coreano, polonês, português (PT-BR), russo, espanhol e vietnamita. Se o prestador de serviços de um cliente necessitar de um idioma diferente dos mencionados, o fornecimento dos serviços de tradução é de responsabilidade do cliente.
ATENÇÃO (PT-PT)	Este manual está disponível apenas em alemão, chinês (ZH-CN), coreano, espanhol, francês, inglês, italiano, japonês, polaco, português (PT-BR), russo e vietnamita. Se o fornecedor de serviços de um cliente necessitar de um idioma diferente dos listados aqui, é da responsabilidade do cliente assegurar os serviços de tradução.
ATENȚIE (RO)	Acest manual este disponibil numai în limbile chineză (ZH-CN), engleză, franceză, germană, italiană, japoneză, coreeană, poloneză, portugheză (PT-BR), rusă, spaniolă și vietnameză. Dacă furnizorul de servicii al unui client solicită o limbă diferită față de aceste limbi, este responsabilitatea clientului să furnizeze servicii de traducere.

ОСТОРОЖНО! (RU)	Настоящее руководство доступно только на китайском (ZH-CN), английском, французском, немецком, итальянском, японском, корейском, польском, португальском (PT-BR), русском, испанском и вьетнамском языках. Если поставщику услуг заказчика требуется руководство на каком-либо другом языке, перевод руководства на необходимый язык осуществляется стороной заказчика.
UPOZORENJE (SR)	Ovaj priručnik dostupan je samo na kineskom (ZH-CN), engleskom, francuskom, nemačkom, italijanskom, japanskom, korejskom, poljskom, portugalskom (PT-BR), ruskom, španskom i vijetnamskom jeziku. Ako korisnik kao pružalac usluge zahteva neki drugi jezik od navedenih, njegova je dužnost da obezbedi prevod.
UPOZORNENIE (SK)	Táto príručka je dostupná len v nasledovných jazykoch: čínština (ZH-CN), angličtina, francúzština, nemčina, taliančina, japončina, kórejščina, poľština, portugalčina (PT-BR), ruština, španielčina a vietnamčina. Ak poskytovateľ služieb daného zákazníka požaduje iný ako tieto jazyky, za poskytnutie prekladateľských služieb zodpovedá zákazník.
ATENCIÓN (ES)	Este manual está disponible solo en chino (ZH-CN), inglés, francés, alemán, italiano, japonés, coreano, polaco, portugués (PT-BR), ruso, español y vietnamita. Si el proveedor de servicios de un cliente requiere un idioma distinto de estos idiomas, es responsabilidad del cliente proporcionar los servicios de traducción.
VARNING (SV)	Den här manualen finns endast tillgänglig på kinesiska (ZH-CN), engelska, franska, tyska, italienska, japanska, koreanska, polska, portugisiska (PT-BR), ryska, spanska och vietnamesiska. Om en kunds tjänsteleverantör behöver ett annat språk än dessa är det kundens ansvar att ordna med översättningstjänster.
OPOZORILO (SL)	Ta priručnik je na voljo v kitajščini (ZH-CN), angleščini, francoščini, nemščini, italijanščini, japonščini, korejščini, poljščini, portugalščini (PT-BR), ruščini, španščini in vietnamščini. Če kupčev ponudnik storitev potrebuje drug jezik, mora za prevod poskrbeti kupec.
DİKKAT (TR)	Bu kılavuz yalnızca Çince (ZH-CN), İngilizce, Fransızca, Almanca, İtalyanca, Japonca, Korece, Lehçe, Portekizce (PT-BR), Rusça, İspanyolca ve Vietnamca dillerinde mevcuttur. Müşteri servis sağlayıcısı bu dillerden başka bir dil talep ederse çeviri hizmeti sağlamak müşterinin sorumluluğundadır.
ЗАСТЕРЕЖЕННЯ (UK)	Цей посібник доступний лише китайською (ZH-CN), англійською, французькою, німецькою, італійською, японською, корейською, польською, португальською (PT-BR), російською, іспанською та в'єтнамською мовами. Якщо постачальник послуг замовника використовує мову, яку не вказано у цьому переліку, послуги з перекладу має забезпечити замовник.

Page intentionally left blank

Contents

Chapter 1 Getting started	9
1.1 Overview	9
1.2 Examining packages for damage in transportation.....	11
1.3 Truck loading specifications	11
1.4 Predelivery instructions.....	14
1.5 Rigging	15
Chapter 2 Unloading and moving the magnet	17
2.1 Shipping and crate configurations	17
2.2 Equipment requirements.....	20
2.3 Removing subsystem crates	21
2.4 Handling the crated magnet in transit with a crane	22
2.5 Handling the crated magnet in transit with a forklift	22
2.6 Removing the shipping cage.....	23
2.7 Removing the shipping crate	25
2.8 Unloading and moving the uncrated magnet with a forklift.....	31
2.9 Unloading the uncrated magnet with a crane to ground	34
2.10 Lifting the magnet with a crane through the opening in the exterior wall	37
Chapter 3 Magnet storage conditions, pending ramp	39
3.1 Connecting the magnet to the compressor	39
3.2 Connecting the magnet monitoring connections.....	44
3.3 Monitoring the magnet	46
Chapter 4 Doing in-transit service and magnet system checks	49
4.1 Preparing to do an in-transit helium refill.....	49
4.2 Doing a magnet system check	51
Chapter 5 Preparing the scan room	53
5.1 Preparing the scan room for leveling an AR series magnet.....	53
Chapter 6 Installing a nonseismic vibroacoustic damping mat and leveling the magnet	63
6.1 Equipment overview	63
6.2 Putting a nonseismic mounted vibroacoustic damping mat into position.....	64
6.3 Preparing to move the magnet.....	65
6.4 Moving the magnet into the MR suite.....	70
6.5 Centering an AR series magnet in the MR suite	70
6.6 Lowering the magnet into position	74

6.7 Adding leveling shims	74
6.8 Leveling an AR series magnet	75
Chapter 7 Installing a seismic vibroacoustic damping mat and leveling the magnet	81
7.1 Equipment overview	81
7.2 Putting a seismic mounted vibroacoustic damping mat into position	82
7.3 Preparing to move the magnet.....	85
7.4 Moving the magnet into the MR suite.....	89
7.5 Lowering the magnet into position	90
7.6 Adding leveling shims	92
7.7 Leveling an AR series magnet	92
7.8 Seismic mounting of a vibroacoustic damping mat to the floor.....	97
Chapter 8 Centering the table dock bolt for an AR series magnet	101
Appendix A Volumetric conversion of Magnet Monitor cryogen percentage to liquid helium level	107
Appendix B <i>Preinstallation Manual</i> reference	109
Revision history	111

Chapter 1 Getting started

1.1 Overview

Safety
<p>Before working in any GE HealthCare MR suite or doing any GE HealthCare service procedure, you must:</p> <ul style="list-style-type: none"> • Have read and understood all hazard conditions and safety requirements in the latest revision of the GE HealthCare <i>MR Service Safety Manual</i> (5452735). • Have successfully completed all relevant GE HealthCare Environmental Health and Safety (EHS) courses (or for non-GE HealthCare employees, equivalent workplace training courses). • Comply with all site-specific training and workplace safety requirements. <p>If you have any safety concerns at any time, do not begin work or immediately stop work and move to a safe location. Immediately contact your supervisor or site safety officer for instructions on how to proceed.</p>

This *Magnet Handling Manual* manual addresses moving, storage, delivery, and installation of an AR series (as defined by the two characters of the magnet serial number) zero boil-off magnet. The sequence of events involved in magnet delivery and installation, along with functions, responsibilities, and associated documentation, are shown in the table below.

Table 1-1 Magnet handling functions and responsibilities

	Function	Responsibility	Reference document
1	MR Magnet Safety Document Review and Compliance	GE HealthCare Project Manager of Installation (PMI), GE HealthCare Field Engineer and Rigger	The <i>MR Service Safety Manual</i> (5452735).
2	Site Delivery and Review: <ul style="list-style-type: none"> • Access and Route • Clearances 	GE HealthCare Project Manager of Installation (PMI), GE HealthCare Field Engineer and Rigger	This <i>Magnet Handling Manual</i> and the appropriate <i>Preinstallation Manual</i> (see Appendix B Preinstallation Manual reference on page 109).
3	Magnet Transportation	Transportation Team, Rigger	Section 1.3 Truck loading specifications on page 11 in this manual.
4	Magnet Delivery	Rigger	Chapter 2 Unloading and moving the magnet on page 17 in this manual.
5	Prepare the Scan Room: <ul style="list-style-type: none"> • Clear the Room • Put the Positioning Template in Position • Set Up the Lasers • Mark the Room for Reference 	GE HealthCare Field Engineer	Chapter 5 Preparing the scan room on page 53 in this manual.
6	Put Vibroacoustic Damping Mats in Position	Rigger	Chapter 6 Installing a nonseismic vibroacoustic damping mat and leveling the magnet on page 63 or Chapter 7 Installing a seismic vibroacoustic damping mat and leveling the magnet on page 81 in this manual.

Table 1-1 Magnet handling functions and responsibilities (Table continued)

	Function	Responsibility	Reference document
7	Moving Magnet to MR Suite	Rigger	Chapter 6 Installing a nonseismic vibroacoustic damping mat and leveling the magnet on page 63 or Chapter 7 Installing a seismic vibroacoustic damping mat and leveling the magnet on page 81 in this manual.
8	Magnet Leveling and Bolt Down	Rigger and GE HealthCare Field Engineer	Chapter 6 Installing a nonseismic vibroacoustic damping mat and leveling the magnet on page 63 or Chapter 7 Installing a seismic vibroacoustic damping mat and leveling the magnet on page 81 in this manual.
9	Magnet Cryocooler Connections pending room installation as soon as possible but no later than 24 hours	GE HealthCare Field Engineer	Chapter 3 Magnet storage conditions, pending ramp on page 39 in this manual.
10	Initial Magnet Setup and Commissioning: <ul style="list-style-type: none"> • Magnet conversion to operating configuration • Exhaust gas vent connection as soon as possible - must be done prior to ramping magnet • Other initial magnet setup procedures 	GE HealthCare Field Engineer	"Initial magnet setup" procedure in the <i>Magnet and Cryogen Manual for 3.0T AR Series Magnets</i> (5871810-8EN).

Photos and images contained within this manual are representative of the system(s) and configuration(s) shipped. The system received may vary slightly.

The latest release of this manual can be obtained through the SIMS Content Viewer or through your GE HealthCare Field Service Representative. Before using this document, make sure you are using the most current released version of this document.

1.2 Examining packages for damage in transportation

Examine all packages closely at delivery. If damage is apparent, do the following:

1. Make sure the notation *damage in shipment* is written on all copies of the freight or express bill before delivery is accepted or signed for by a GE HealthCare representative or a hospital receiving agent.
2. Whether noted or concealed, you must report damage to the carrier immediately upon discovery, or in any event, within 14 days after receipt, and hold the contents and containers for inspection by the carrier. A transportation company will not pay a claim for damage if an inspection is not requested within this 14-day period.
3. Call Global Parts at 1-800-548-3366 (option 6) to file a report of the damage.



NOTE

Contact your local service coordinator for more information on this process.

1.3 Truck loading specifications

Safety
<div style="background-color: #0056b3; color: white; padding: 2px; display: inline-block; margin-bottom: 5px;">NOTICE</div> <p>EQUIPMENT DAMAGE RISK</p> <p>Improper transportation can result in damage to the magnet.</p> <p>Review guidelines with the carrier prior to transporting the magnet. Any other shipping configuration must be demonstrated through testing and be approved by GE Health-Care.</p>
Required conditions
Air ride trailers must be used.
The magnet must be centered on the trailer with the magnet bore parallel to the truck.
The magnet must not be put over the trailer axles.
Extreme care must be used during forklift use. The magnet crate must be picked up from the sides only. The forks must be put directly under the four magnet feet. The magnet can be identified by the steel plates attached to the pallet. See Chapter 2 Unloading and moving the magnet on page 17 for more detailed handling requirements pertaining to forklift and/or crane moves.
Crate and/or frame top and sides must not be used to secure the magnet to the trailer. Magnets should be secured to the trailer using crate/magnet base.

Required conditions

A maximum of two magnets per trailer is allowed. Acceptable dual load configurations are as follows:

- Two 3.0T (AR or UA series) magnets
- One 1.5T (HM, PM, R, or RD series) magnet and one 3.0T (AR or UA series) magnet

Figure 1-1 Single magnet ground transportation truck loading requirements, tarped configuration (left) and crated configuration (right)

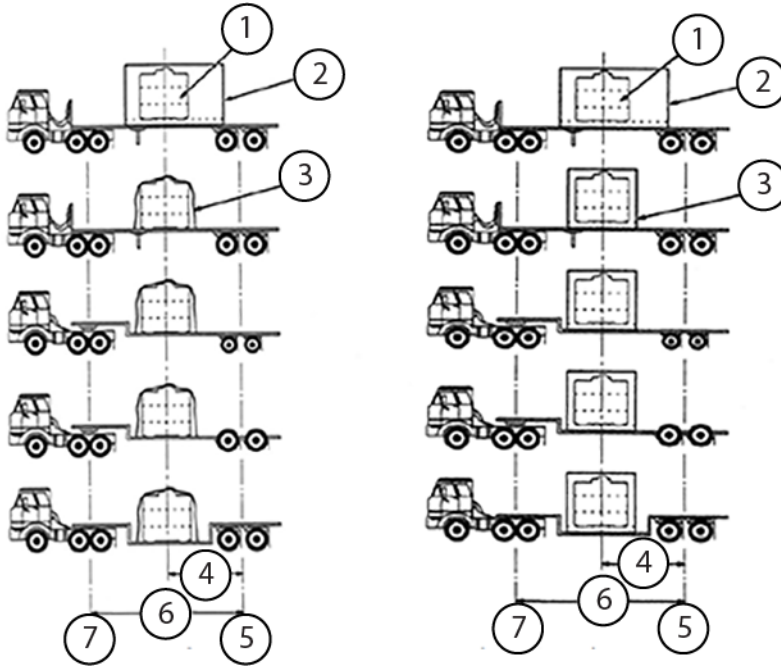

Item	Description	Item	Description
1	Magnet	5	Rear axle centerline
2	ISO box container	6	Length from king pin centerline to rear axle centerline (L)
3	Tarp (left) or crate (right)	7	King pin centerline
4	Length from the midpoint to the rear axle centerline (L/2)	-	-

Required conditions

Figure 1-2 Two magnet ground transportation truck loading requirements, tarped configuration (left) and crated configuration (right)

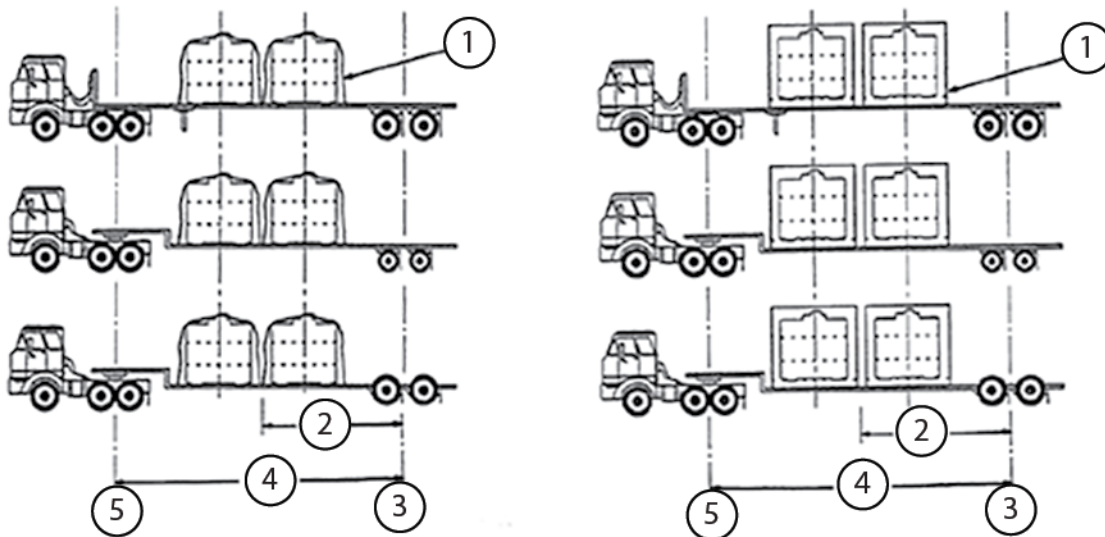

Item	Description	Item	Description
1	Tarp (left) or crate (right)	4	Length from king pin centerline to rear axle centerline (L)
2	Length from the midpoint to the rear axle centerline (L/2)	5	King pin centerline
3	Rear axle centerline	-	-

Table 1-2 Magnet loading specifications

Max tilt when suspended by lifting lugs	30°
Allowable shipping modes	<ul style="list-style-type: none"> • Airplane (any plane that has openings large enough to accept a magnet) • Air ride trailer (see Figure 1-1 Single magnet ground transportation truck loading requirements, tarped configuration (left) and crated configuration (right) on page 12 and Figure 1-2 Two magnet ground transportation truck loading requirements, tarped configuration (left) and crated configuration (right) on page 13) • Boat or ocean-going ship
Forklift capability	Yes
Shipping temperature	-30 to 50°C (-22 to 122°F)
Maximum shock load	1.5g

1.4 Predelivery instructions

Safety

NOTICE

EQUIPMENT DAMAGE RISK

Impacts/jolts/drops to the magnet while lifting/moving/lowering the magnet can cause expensive internal magnet damage.

The rigger is responsible for actual equipment/procedures used to lift and move a magnet into the customer facility, including through a raised opening in an exterior wall. The following EXAMPLE procedure only outlines the concept of one method.

Lift/move/lower the magnet smoothly. Do not let the magnet bump or hit anything forcefully. Avoid tilting the magnet more than the maximum tilt (30° from horizontal level). Do not apply any force to the magnet enclosures. Protect all customer surfaces during any and all move operations.

NOTICE

IMAGE QUALITY RISK

Improperly located anchors can cause image quality issues.

Make sure that all equipment anchors are located in conformance with the site's architectural drawings and are installed and tested per the *Anchor Hardware Requirements for MR Equipment inside RF Shield Room* section of the appropriate *Preinstallation Manual* (see [Appendix B Preinstallation Manual reference on page 109](#)).

1. Before magnet delivery, the GE HealthCare PMI and rigger must do the following:
 - 1.1. Visit the magnet site with the rigging foreman before magnet delivery to plan the move. The GE HealthCare PMI must hand-deliver a copy of this document to the rigging foreman.
 - 1.2. Review the guidelines for shipping/handling and for equipment/tools with the rigging foreman per [Chapter 2 Unloading and moving the magnet on page 17](#) in this manual.
 - 1.3. Caution the rigger that the magnet is extremely fragile. Sudden jolts can damage the magnet. (Make riggers aware of the cost of a magnet replacement. This usually promotes more care while handling the magnet.)
 - 1.4. Make sure all routes and paths leading to the magnet room are level and free from obstacles and holes. (The rigger will be required to construct platforms where needed.)
 - 1.5. Make sure that clearance dimensions along the path to the magnet room meet the requirements stated in the *Preinstallation Manual* (see [Appendix B Preinstallation Manual reference on page 109](#)). In the case of a magnet being lifted by a crane through a raised opening, make sure the opening is of sufficient size to fit the magnet and all rigging equipment without interference.
 - 1.6. If roller dollies are to be used, have the rigger bring steel plates to put along the delivery route.
 - 1.7. The rigger must take actions necessary to ensure that walls, floors, and so on along the transportation route/path are protected from potential damage.

- 1.8. The GE HealthCare PMI and rigger must review the *Rigging* guidelines (see [1.5 Rigging on page 15](#)).
2. Before magnet delivery, the GE HealthCare PMI and Shield Room Vendor must do the following:
 - 2.1. Make sure that floor levelness specifications stated in the *Preinstallation Manual* (see [Appendix B Preinstallation Manual reference on page 109](#)) are met after the finished flooring is installed.
 - 2.2. Make sure that the vent is located according to the specifications stated in the *Preinstallation Manual* (see [Appendix B Preinstallation Manual reference on page 109](#)).
 - 2.3. Make sure that markings are present on the magnet room floor in accordance to the specifications stated in the *Preinstallation Manual* (see [Appendix B Preinstallation Manual reference on page 109](#)).

1.5 Rigging

This section provides guidance on lifting a GE HealthCare MRI magnet.



DANGER

DEATH OR SERIOUS INJURY

MRI magnets have unique shapes which increases the difficulty of rigging and may result in **bodily harm or in severe cases, death**, if done incorrectly since the load may fall/tip.

Review the following chapters in their entirety to make sure the MRI magnet lifting requirements are clearly understood.

- [Chapter 2 Unloading and moving the magnet on page 17](#)
- [Chapter 6 Installing a nonseismic vibroacoustic damping mat and leveling the magnet on page 63](#)
- [Chapter 7 Installing a seismic vibroacoustic damping mat and leveling the magnet on page 81](#)











These chapters detail the MRI weights, dimensions, lifting anchor points, and forklift access areas. GE HealthCare MRI magnets can only be rigged from the lifting anchor point and forklift access areas specified in this manual.

Removing the MRI magnet off the flatbed trailer and putting the MRI magnet at its final location is the **responsibility of the rigging company**.

Although lift plans are only required for lifts that are considered a critical lift by GE HealthCare standards, GE HealthCare strongly recommends that a thorough lift plan is developed and reviewed with a GE HealthCare representative for all crane lifts, **preferably using the GE HealthCare Lift Plan template which can be provided by the GE HealthCare EHS team**. Following the review, if changes are required, discuss and review the plan (with a GE HealthCare representative) prior to the lift to make sure all parties are satisfied with the lift plan execution, and can safely lift and move the magnet to the desired location.





Shown below are lifesaving principals for rigging MRI magnets that should be followed on the day of delivery to help make sure lifting occurs safely.

Figure 1-3 Life saving principals

 <p>For Platform Lifts: A controlled method must be used for moving the magnet off the platform into the room in small precise increments. This will allow for communications to occur to the crane operator, and for the crane operator to adjust the platform to accommodate for the changes in the load and CG.</p>	 <p>No cell phones should be allowed in the cab of the crane while the magnet is being moved.</p>	 <p>If any situations arise the day of the delivery that prevents the lift plan from being executed exactly the way it was written and approved, then a Stop Work must be issued.</p>
 <p>The crane must have a load sensor that can be monitored from the cab of the crane to see when the load is changing based on the magnet movement on the platform.</p>	 <p>Clear, dependable means of audible communications must be used between the crane operator and the person managing the operation from the platform/room.</p>	 <p>If the requested permit time is denied by the issuing body or if unforeseen issues arise the day of the delivery that creates time delays, then the project schedule should be reviewed with GE and the customer to ensure the allotted time is sufficient.</p>
 <p>For Platform Lifts: The platform must be anchored securely to the building.</p>	 <p>No one shall be in the potential drop zone of the magnet during the lift or while the magnet is being pulled into the room from the lift platform. No one should be in this exclusion zone while the magnet is in a dynamic state.</p>	 <p>If the customer denies any requests made by the crane company affecting the lift plan or would prevent the platform from being securely anchored to the building, then a Stop Work must be issued.</p>
 <p>For Platform Lifts: The magnet must be moved in the direction of the bore/orange rails.</p>		

Chapter 2 Unloading and moving the magnet

2.1 Shipping and crate configurations

Safety	
	<p>⚠ DANGER</p> <p>POTENTIAL ASPHYXIATION HAZARD</p> <p>Loss of magnet vacuum will result in the rapid expulsion of helium gas, which can cause asphyxiation in enclosed areas.</p> <p>Use extreme caution and do not contact or damage the vacuum vessel during magnet transit or siting.</p>
	<p>⚠ WARNING</p> <p>POTENTIAL INJURY</p> <p>Magnet is an unbalanced load. Tilting can result in a hazardous condition that can cause magnet damage or serious personal injury.</p> <p>Do the following to avoid tilting:</p> <ul style="list-style-type: none"> • Make sure that the lifting apparatus (crane, spreader beam, and so on) meets the specifications stated in this manual. • Put the spreader beam (if used) parallel to the lifting rails. • Adjust the lifting cables/slings and spreader beam (if used) lift point to level the magnet before fully lifting the magnet off the surface. • Make sure that the entire area where lifting will occur is free of obstructions and unauthorized personnel. • Make sure the surface where the magnet will be put after lifting is flat. • Do not crane lift a magnet during dangerous weather conditions.
	<p>⚠ CAUTION</p> <p>HEAVY EQUIPMENT</p> <p>Two people are required to lift the magnet lifting rails.</p>
	<p>⚠ WARNING</p> <p>RISK OF DEATH, PERSONAL INJURY, OR EQUIPMENT DAMAGE</p> <p>The use of used and/or damaged bolts, lock washers, flat washers, and nuts could result in equipment and/or component damage, death, or serious physical injury!</p> <p>Use new, undamaged mounting hardware.</p>

Safety**NOTICE****COMPONENT DAMAGE RISK**

Improper transportation can result in damage to the magnet.

Tasks in this section are to be done by riggers, not by GE HealthCare Personnel.

Weights referenced in section [2.2 Equipment requirements on page 20](#) are rigging weights (rounded up from actual weights) and are not actual shipping weights. Refer to magnet shipping documents for actual weights of the magnet and crate.

Do not use a crane to lift a magnet that is on a pallet or inside a crate. Crane lifting can only be done using the magnet lifting rails, which are not accessible while the magnet is inside the crate.

Domestic Shipping Crate (5151624)

Figure 2-1 Shipping crate



- Approved for use on truck transportation only. (Not approved for flight or ocean usage.)
- Cage/frame is put over/around the magnet after the magnet is loaded onto truck.
- Cage must be removed prior to magnet unload from truck (making orange beams accessible).

Platform International Shipping Crate (5806856)

Figure 2-2 Fork position

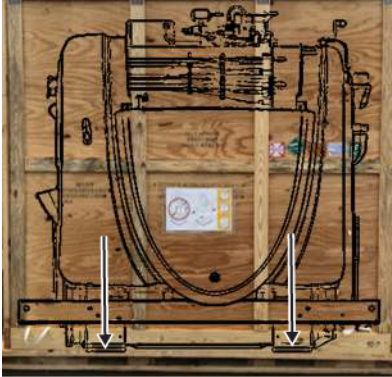

NOTE

Magnet image superimposed on crates is for reference only. Magnet image shown is representative and may differ from the configuration shipped.

- Approved for use on truck, ocean, or air transportation.
- Forklift approved moves only. (Crane movement of magnet in crate is not permitted.)
- Crate is designed to put forklift forks directly beneath magnet feet - lifting from the side of the magnet, perpendicular to the magnet bore.
- Minimum distance between forks = 1016 mm (40 inches).

2.2 Equipment requirements

Table 2-1 Forklift requirements*

Item and quantity	Equipment specification/rating		Furnished by	Function
Forklift quantity = 1	Magnet weight only (as shipped configuration with gradient, does not include crate)	5882 kg (12,968 lbs)	Rigger	Unloading or moving magnet
	Crated magnet weight	6633 kg (14,622 lbs)		
	Magnet only - minimum distance between forks using lifting rails	2032 mm (80 inches)		
	Crated magnet - minimum distance between forks	Platform International Shipping Crate (5806856): 1016 mm (40 inches)		
	Minimum fork length	2363 mm (93 inches)		
*Forklift and forklift equipment must be rated for the referenced magnet loads.				

Table 2-2 Crane requirements*





Item and quantity	Equipment specification/rating		Furnished by	Function
Crane quantity = 1	Magnet weight only (as shipped configuration with gradient, does not include crate)	5882 kg (12,968 lbs)	Rigger	Unloading or moving magnet
	Crate weight only	751 kg (1,654 lbs)		
Spreader beam quantity (if used) = 1	Distance between lifting points, underside of spreader beam	2286 mm to 2439 mm (90 inches to 96 inches)		
Slings, hoists, bridles, shackles	Requirement to be determined by rigger.  NOTE Refer to magnet weights noted above.			
*Crane and crane equipment must be rated for the referenced magnet loads.				

Table 2-3 Miscellaneous equipment and tools*

Item	Equipment/tool required	Responsible	Function
Magnet mechanical interface drawing (bare magnet)  NOTE Interface drawings may not contain shipping configurations and are for reference only	See clearance dimensions in 6.3 Preparing to move the magnet on page 65 .	Project manager of installation (PMI)	Identifying magnet dimension and features
Magnet weight only (as shipped configuration with gradient, does not include crate)	5882 kg (12,968 lbs)	Reference	Moving the magnet
Hydraulic or toe jack	Must support one end of magnet on two jacks or both ends of magnet on four jacks.  NOTE Refer to magnet weights noted above.	Rigger	Raising the magnet for roller dollies or leveling plates
Roller dollies	Must support magnet on at least three dollies. (Four dollies must be installed; however, the dollies must be able to support full weight on three dollies in case one foot is not touching.)  NOTE Refer to magnet weights noted above.	Rigger	Moving the magnet
Magnet Leveling Shim Kit	5819317	GE HealthCare Field Engineer	Leveling the magnet
PH Alignment and Magnet Leveling Kit	5897979	GE HealthCare Field Engineer	Leveling the magnet

*Miscellaneous equipment and tools must be rated for the referenced magnet loads.

2.3 Removing subsystem crates

- Carefully inspect all packaging for damage that may have occurred during shipping.
- Remove all subsystem crates, except the magnet crate, from the trailer/transport using a crane or forklift. To handle the magnet crate in transit from the truck or plane, see [2.5 Handling the crated magnet in transit with a forklift on page 22](#).

3. Inspect all crates for visible damage. Report any damage you find in conformance with the [1.2 Examining packages for damage in transportation on page 11](#) procedure.
4. Move subsystem crates to a receiving location protected from the weather, preferably close to and at the same level as the MR suite/magnet room.

2.4 Handling the crated magnet in transit with a crane

Do not use a crane to move the magnet if it is still in the crate. Using a crane requires clear access to the orange lifting beams, which are not accessible while the magnet is inside the crate.

2.5 Handling the crated magnet in transit with a forklift

Safety

NOTICE

EQUIPMENT DAMAGE RISK

Improper transportation during forklift operations can result in magnet damage.

Forklift must meet the minimum capacity and dimension requirements stated in section [2.2 Equipment requirements on page 20](#).

The magnet must be picked up from the magnet side orientation only with the forks inserted into the designated slots on the crate.

Avoid sudden jolts. Do not allow the crate/pallet to bump anything forcefully.

Avoid tilting the magnet/crate/pallet package more than the maximum tilt specified (30° from the horizontal level).

1. Put a forklift in position beside the magnet crate/pallet meeting the requirements stated in section [2.2 Equipment requirements on page 20](#).

- Carefully insert the forklift forks completely into the holes in the long side of the shipping pallet.

Figure 2-3 Forklift lifting points of magnet/crate/pallet package

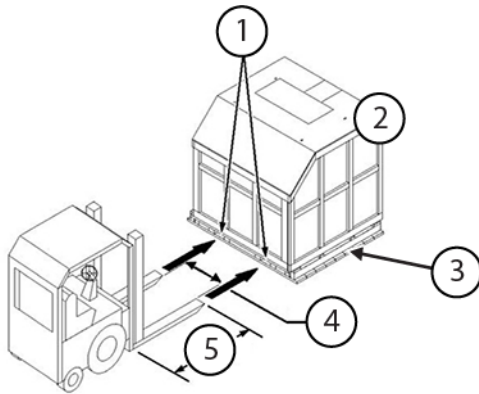

1	Insert forks here only
2	Crate
3	Pallet
4	Crated magnet - minimum distance between forks: Platform International Shipping Crate (5806856): 1016 mm (40 inches)
5	Minimum fork length, 2363 mm (93 inches)

- Smoothly lift the crate/pallet with the forklift, and move the crate/pallet to the desired location.



NOTE

Magnet lift must be perpendicular to magnet bore. Crate slots for forklift are designed to ensure proper lift orientation.

- Lower the entire package to rest on a flat, smooth surface. Do not rest the magnet/crate/pallet on any surface that is not flat or strong enough to support the magnet/crate/pallet package.
- Avoid tilting the magnet; every effort should be made to minimize tilt during transport or movement. Tilt must not exceed 30° from the horizontal level.

2.6 Removing the shipping cage

Safety
<p>NOTICE</p> <p>EQUIPMENT DAMAGE RISK</p> <p>Improper removal of the shipping cage can result in damage to the magnet.</p> <p>Do not use a crane to move the magnet if it is still in the cage. If you are using a crane, you need clear access to the orange lifting beams, which are not accessible while the magnet is inside the cage.</p> <p>Remove the magnet's shipping cage while the magnet/cage/pallet package is on the trailer/transport.</p>

Safety

NOTICE

EQUIPMENT DAMAGE RISK

Care must be taken not to scrape or hit the sides of the magnet. The magnet is shipped inside plastic bubble wrap. The bubble wrap should be left intact until the magnet is set down inside the magnet room. Take care not to nick or cut any electrical cables during removal of the plastic bubble wrap. The sample shipping cage configuration (domestic shipping option) below shows intact bubble wrap.

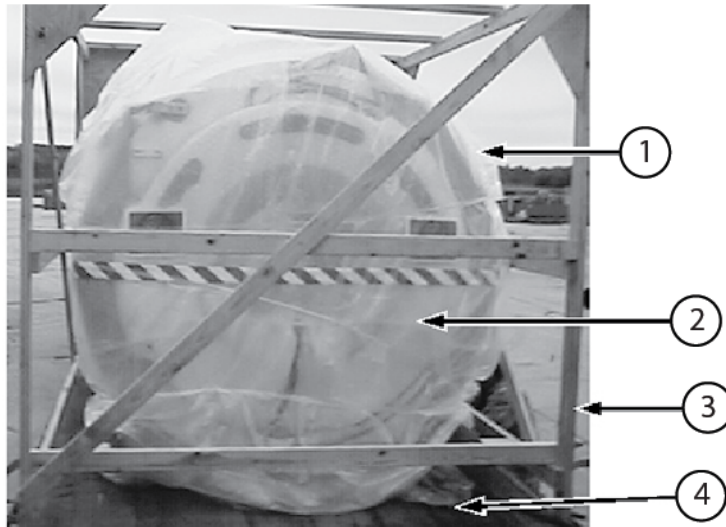

1	Plastic bubble wrap
2	Magnet
3	Cage
4	Pallet

1. Remove the driver-supplied tarp from the shipping cage.
2. Unstrap the cage if any straps were applied. Then unchain the magnet from the flatbed.
3. To remove the shipping cage from the magnet, follow the steps below for one of the options:

Using a crane	<ol style="list-style-type: none"> 1. Strap the frame in four locations. 2. Lift the cage straight up and move it away from the magnet.
Not using a crane	<ol style="list-style-type: none"> 1. Unbolt the boards on one end of the cage. 2. Move the cage away from the magnet in the other direction.

4. Before trying to unload and move the magnet into the building, make sure the magnet pressure is ≤ 3 psig. If the pressure is greater than 3 psig, contact the Online Center or Florence before continuing.

2.7 Removing the shipping crate

Safety

NOTICE**EQUIPMENT DAMAGE RISK**

Improper removal of the shipping crate can result in damage to the magnet.

Do not use a crane to move the magnet if it is still in the crate. If you are using a crane, you need clear access to the orange lifting beams, which are not accessible while the magnet is inside the crate.

Remove the magnet's shipping crate while the magnet/crate/pallet package is on the trailer/transport.

Damage to the magnet and/or magnet enclosures may result if the crate is removed while the crate's side panels are in their closed (shipping) position, or if the crate is disassembled while the magnet is inside the crate.

Do not remove any lag screws on the crate or pallet until the crane is in position, and the slings/cable bridles are attached to the lifting rings on the crate.

1. Remove the driver-supplied tarp from the shipping crate.
2. Unchain the crate from the flatbed.
3. Put a crane meeting the specifications in [Table 2-2 Crane requirements*](#) on page 20 above the center of the crate.

- Attach the slings/cable bridles of a spreader beam to the lifting rings on top of the crate.



NOTE

Either a hook/shackle and slings or a spreader beam and sling/cable bridles may be used during crate removal.

Figure 2-4 Crane positioning, lag screw removal to open crate side panels

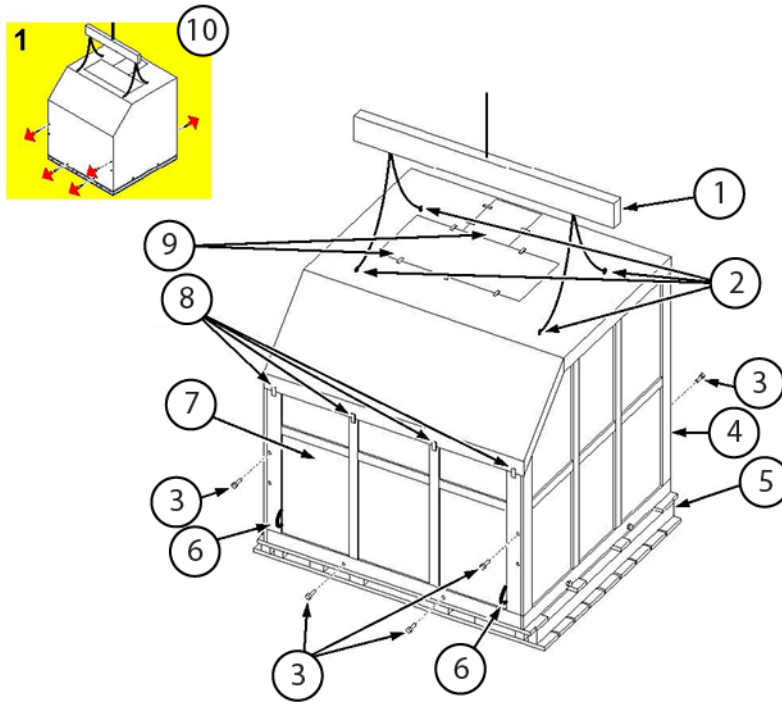

Item	Description	Item	Description
1	Spreader beam with slack lifting straps/ cables	6	Rope handle
2	Four lifting rings for lifting crate	7	Crate side panel
3	Lag screw	8	Side panel hinges
4	Front of crate	9	Access panels
5	Front of pallet	10	Graphic on crate

- Remove the lag screws along the lower edges of the crate's left and right side panels that secure those panels to the pallet. Do not remove the lag screws securing the crate's front and back end panels to the pallet until after the crate's side panels are secured in their open position.
- Remove the lag screws securing the crate side panels to the crate end panels. Do not remove the hinges along each crate side panel's upper edge.

7. Pull open the crate's left and right side panels using the rope handle on each side panel. The crate's left and right side panels are hinged along their upper edges.

Figure 2-5 Securing crate side panels in open position

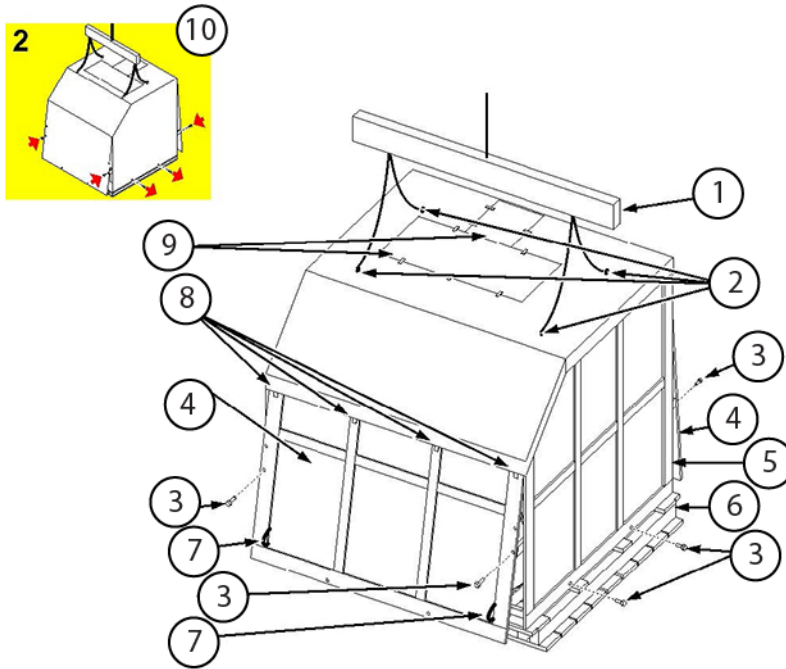

Item	Description	Item	Description
1	Spreader beam with slack lifting straps/ cables	6	Front of pallet
2	Four lifting rings for lifting crate	7	Rope handle
3	Lag screw	8	Side panel hinges
4	Crate side panel	9	Access panels
5	Front of crate	10	Graphic on crate



NOTE

This figure shows the use of a spreader beam and cable bridles/slings. You can also use a hook or shackle and slings. All equipment must meet or exceed the size and loading specifications stated in this manual.

8. Swing the wooden block found inside each vertical corner of the crate outward.

Figure 2-6 Rear view of shipping crate with side panels raised

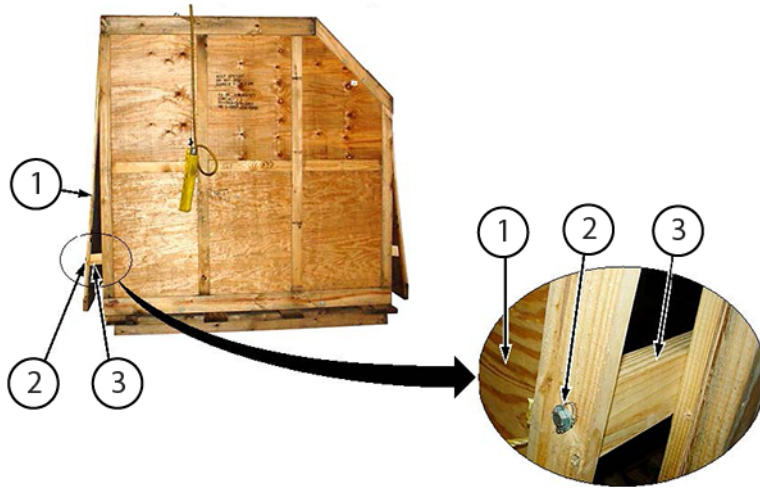

1	Side panel
2	Lag screw
3	Wooden block

9. Attach the loose end of each block to the adjoining side panel using one of the lag screws removed previously.
10. Remove the lag screws along the lower edges of the crate’s front and back end panels that secure those panels to the pallet. Refer to [Figure 2-5 Securing crate side panels in open position on page 27](#).

11. Tighten the slings/cable bridles and carefully begin lifting the crate. (Refer to graphic 3 on the shipping crate.) If the crate does not remain approximately level, carefully lower the crate and adjust the lifting configuration, then lift the crate again.

Figure 2-7 Lifting the crate using a crane

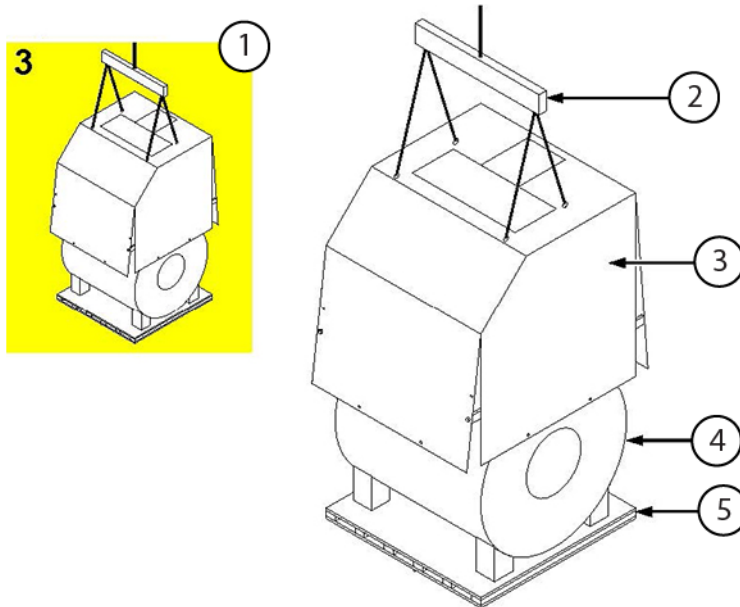

Item	Description	Item	Description
1	Graphic on crate	4	Magnet
2	Spreader beam with slack lifting straps/cables	5	Pallet
3	Crate	-	-



NOTE

This figure shows the use of a spreader beam and cable bridles/slings. You can also use a hook or shackle and slings. All equipment must meet or exceed the size and loading specifications stated in this manual.

12. Using the crane, lift the crate top off the magnet's shipping pallet and fully above and clearing the magnet.
13. Put the crate in a clear area.

14. Unbolt and remove the four bolts (one per magnet foot) securing the magnet feet to the pallet.

Figure 2-8 Unbolting the magnet from a shipping pallet



15. Visually examine the witness marks on each bolt and orange lifting rail at each of the four magnet feet. Look for witness mark misalignment between the nut/bolt head and the orange lifting rail.



NOTE

See the examples below for correctly aligned witness marks.

Figure 2-9 Legacy process, pre-2023 and possible storage



Figure 2-10 New process, starting mid-2023



- If witness marks are aligned correctly, continue with [Step 16](#).
- If witness marks do not align as shown above, complete these steps:
 - 15.2.1. Make sure the rails are installed against the magnet feet at all four locations.
 - 15.2.2. Look inside of the magnet foot. If a through bolt is used (new process), make sure the lock washer is compressed under the bolt head. If it is not, tighten the bolt until the lock washer is compressed, but do not exceed 90 ft-lbs (122 N m).



NOTE

If the nut turns (new process only) but does not tighten, then the bolt hole on the magnet foot was drilled out and the head of the bolt (which is inside the magnet foot) will need to be held by a second wrench while torquing the nut.

- 15.2.3. Torque the bolt head (legacy) or nut (new process) to 90 ft-lbs (122 N m) on the outside of the orange rail.

**NOTE**

Do not use powered torque drivers. Powered drivers may supply higher torque that can damage the bolts. Do not overtighten the bolts/nuts.

- 15.2.4. Use a permanent marker to add a new witness mark only on the bolt or nut that was just torqued.
- 15.2.5. Continue with [Step 16](#).
16. Before trying to unload and move the magnet into the building, make sure the magnet pressure is ≤ 3 psig. If the pressure is greater than 3 psig, contact the Online Center or Florence before continuing.
17. Rig and lift the magnet off the pallet in conformance with section [2.8 Unloading and moving the uncrated magnet with a forklift on page 31](#) or section [2.9 Unloading the uncrated magnet with a crane to ground on page 34](#) of this manual.

2.8 Unloading and moving the uncrated magnet with a forklift

Safety

 **CAUTION**

 **POTENTIAL INJURY HAZARD**

Pushing magnet enclosures may result in bodily injury to personnel.

Do not push magnet enclosures. Follow the directions on the six "Do Not Push" signs (one on each side, and two on each end).



DO NOT PUSH !!!



DO NOT PUSH !!!



Safety**NOTICE****EQUIPMENT DAMAGE RISK**

Improper transportation can result in magnet damage.

Do the following to prevent magnet damage:

- Do not apply any force to the magnet enclosures.
- Only use equipment/tools that meet the specifications stated in section [2.2 Equipment requirements on page 20](#).
- Do not move the magnet to the MR Suite while the magnet is on its shipping pallet. Before moving the magnet to the MR Suite, refer to [Chapter 2 Unloading and moving the magnet on page 17](#).

NOTICE**EQUIPMENT DAMAGE RISK**

Improper transportation during forklift operations can result in magnet damage.

Forklift must meet the minimum capacity and dimension requirements stated in section [2.2 Equipment requirements on page 20](#).

The magnet must be picked up from the magnet side orientation only with the forks inserted into the designated slots on the crate.

Forklift forks can damage the magnet enclosure or components. Use protective padding around the forks.

Avoid sudden jolts. Do not let the crate/pallet bump or hit anything forcefully.

Avoid tilting the magnet/crate/pallet package more than the maximum tilt specified (30° from the horizontal level).

**NOTE**

The rigger is responsible for actual equipment/procedures used to lift and move a magnet into the customer facility, including through a raised opening in an exterior wall. The following procedures are guidelines only. It is the responsibility of the rigger to safely move the magnet into the facility.

1.

**NOTE**

See [Step 15 in 2.7 Removing the shipping crate on page 25](#) for the procedure on examining witness marks before lifting with the orange rails.

Put a forklift that meets the specifications in section [2.2 Equipment requirements on page 20](#) at the side of the magnet facing the magnet. Put the forks under the lifting rails to the outside of the magnet feet.

Figure 2-11 Forklift under lifting rails

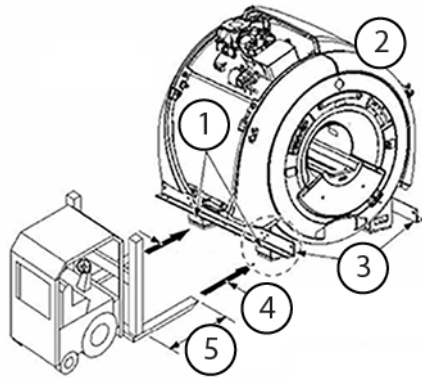

Item	Description	Item	Description
1	Magnet feet	4	2032 mm (80 inches) inside forks, minimum
2	Magnet (protective wrap not shown)	5	2363 mm (93 inches) minimum
3	Lifting rails	-	-



NOTE

Figure is not to scale. Put the forks under the lifting rails, outside of the magnet feet.

- Carefully drive the forklift until the forks are completely under both lifting rails in the areas shown in [Figure 2-11 Forklift under lifting rails on page 33](#).



NOTE

The forks must be put in position under both ends of the lifting rails outside of and 254 mm (10 inches) away from the magnet feet. The outsides of the feet are 1524 mm (60 inches) apart. The lifting rails are 2388 mm (94 inches) long.

- Lift the forks to right below the lifting rails, adjust the distance between forks so that padded forks lightly touch the enclosure, and finish raising the forks to the lifting rails.
- Lift the magnet with the forklift.
- Smoothly move the magnet to the desired location, and carefully lower to rest on a flat surface.

2.9 Unloading the uncrated magnet with a crane to ground

Safety



WARNING

POTENTIAL SERIOUS INJURIES

Moving a magnet through a raised opening in an exterior wall can result in serious injuries and magnet/equipment damage.

Do the following before moving the magnet:

- Make sure a complete walk-through of the crane lift process was done prior to the actual event to make sure all process details are covered.
- Make sure all necessary equipment is on-site and inspected for safety and load ratings.
- Make sure all necessary personnel are trained and ready.
- Make sure that the entire area where lifting will occur is free of obstructions and unauthorized personnel.
- Make sure the surface where the magnet will be put after lifting is flat.
- Do not crane lift a magnet during dangerous weather conditions.



WARNING

POTENTIAL INJURY HAZARDS

Improper lifting of the magnet may be hazardous to personnel and can result in damage to the magnet and equipment.

Make sure that the entire area where lifting will occur is free of obstructions and unauthorized personnel.

Make sure that the surface where the magnet will be put after lifting is flat.

NOTICE

EQUIPMENT DAMAGE RISK

Improper transportation can result in expensive internal damage to the magnet.

Avoid sudden jolts. Lift/move/lower the magnet smoothly. Do not allow the magnet to bump or hit anything forcefully.

Avoid tilting the magnet more than the maximum tilt (30° from the horizontal level).

Do not apply any force to the magnet enclosures.

Do not crane lift a magnet that is on a pallet or inside a cage or crate.

Crane lifting can only be done using the magnet lifting rails, which are not accessible while the magnet is inside a cage or crate.

Safety**NOTICE****EQUIPMENT DAMAGE RISK**

Improper crane transportation can result in damage to the magnet.

Do not crane lift crated/palletted magnets. Crated/palletted magnets must be handled in conformance with the other sections in [Chapter 2 Unloading and moving the magnet on page 17](#) of this manual.

Only a rigger should unload and move the magnet.

**NOTE**

The rigger is responsible for actual equipment/procedures used to lift and move a magnet into the customer facility, including through a raised opening in an exterior wall. The following procedures are guidelines only. It is the responsibility of the rigger to safely move the magnet into the facility.

1. Make sure that there are no obstructions in the area where lifting will occur and that a flat surface is available to put the magnet after lifting.
2. Put the hook of a crane and spreader beam (if used), which meet the specifications stated in [section 2.2 Equipment requirements on page 20](#), centrally over the magnet to ensure a vertical lifting force on the lifting cables/slings. If a spreader beam is not used, make sure that the strap length and crane lifting height are long enough so that the straps do not contact any part of the magnet above the magnet lifting beam and the magnet can reach the desired height.

**NOTE**

Align the spreader beam parallel to the magnet bore.

**NOTE**

Make sure the cable bridles/slings do not touch the magnet covers.

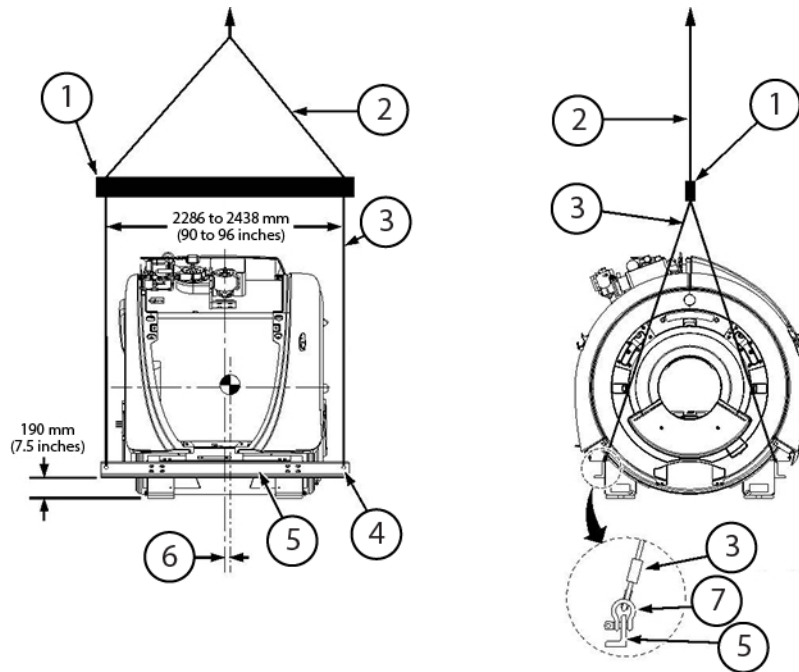
Figure 2-12 Crane lift configuration, magnet side view (left) and front view (right)

Item	Description	Item	Description
1	Spreader beam with top rigging	5	Lifting rail
2	Two-legged cable bridle/sling (spreader beam to crane)	6	Center of gravity (CG), offset approximately 25 mm (1 inch) to rear of magnet isocenter
3	Two-legged cable bridle/sling (spreader beam to lifting rail)	7	Shackle (typically 4 locations)
4	Lifting holes (each end of each lifting rail)	-	-

3.  **NOTE** See [Step 15](#) in [2.7 Removing the shipping crate on page 25](#) for the procedure on examining witness marks before lifting with the orange rails.

Attach the rigging to the lifting cables/slings at each end of the magnet.

-  **NOTE** Wire rope is recommended for better length match and stretch control.

4. Attach the bridle slings to the magnet lifting rails with 25 mm (1.0 inch) pin shackles.
5. When beginning to lift the magnet, if it does not remain close to level, carefully lower the magnet and adjust the lifting configuration, and then lift the magnet again.
6. Smoothly move the magnet to the desired location, and carefully lower so it rests on a flat surface.

2.10 Lifting the magnet with a crane through the opening in the exterior wall

Safety



WARNING

POTENTIAL SERIOUS INJURIES

Moving a magnet through a raised opening in an exterior wall can result in serious injuries and magnet/equipment damage.

Do the following before moving the magnet:

- Make sure a complete walk-through of the crane lift process was done prior to the actual event to make sure all process details are covered.
- Make sure all necessary equipment is on-site and inspected for safety and load ratings.
- Make sure all necessary personnel are trained and ready.
- Make sure that the entire area where lifting will occur is free of obstructions and unauthorized personnel.
- Make sure the surface where the magnet will be put after lifting is flat.
- Do not crane lift a magnet during dangerous weather conditions.



WARNING

POTENTIAL INJURY HAZARDS

Improper lifting of the magnet may be hazardous to personnel and can result in damage to the magnet and equipment.

Make sure that the entire area where lifting will occur is free of obstructions and unauthorized personnel.

Make sure that the surface where the magnet will be put after lifting is flat.

NOTICE

EQUIPMENT DAMAGE RISK

Improper transportation can result in expensive internal damage to the magnet.

Avoid sudden jolts. Lift/move/lower the magnet smoothly. Do not allow the magnet to bump or hit anything forcefully.

Avoid tilting the magnet more than the maximum tilt (30° from the horizontal level).

Do not apply any force to the magnet enclosures.

Do not crane lift a magnet that is on a pallet or inside a cage or crate.

Crane lifting can only be done using the magnet lifting rails, which are not accessible while the magnet is inside a cage or crate.

Safety**NOTICE****EQUIPMENT DAMAGE RISK**

Improper crane transportation can result in damage to the magnet.

Do not crane lift crated/palleted magnets. Crated/palleted magnets must be handled in conformance with the other sections in [Chapter 2 Unloading and moving the magnet on page 17](#) of this manual.

Only a rigger should unload and move the magnet.

**NOTE**

The rigger is responsible for actual equipment/procedures used to lift and move a magnet into the customer facility, including through a raised opening in an exterior wall. The following procedures are guidelines only. It is the responsibility of the rigger to safely move the magnet into the facility.

1. Make sure that the opening is at least 2439 mm (96 inches) wide and 2591 mm (102 inches) tall, minimum. The magnet should pass through the opening side first without hitting the opening.

**NOTE**

A larger opening will make both the operation easier and accidental magnet damage less likely.

2. Put the hook of a crane and spreader beam (if used), which meet the specifications stated in section [2.2 Equipment requirements on page 20](#), centrally over the magnet to ensure a vertical lifting force on the lifting cables/slings (see [Figure 2-12 Crane lift configuration, magnet side view \(left\) and front view \(right\) on page 36](#)). If a spreader beam is not used, make sure that the strap length and crane lifting height are long enough so that the straps do not contact any part of the magnet above the magnet lifting beam and the magnet can reach the desired height.

**NOTE**

Align the spreader beam parallel to the magnet bore.

**NOTE**

Make sure the cable bridles/slings do not touch the magnet covers.



3. Rig the magnet with chain hoists toward the building, lifting cables/slings away from the building and a spreader beam.
4.  **NOTE** See [Step 15 in 2.7 Removing the shipping crate on page 25](#) for the procedure on examining witness marks before lifting with the orange rails.

Attach lifting straps to both ends of the lifting rail to face toward the building.

5. When beginning to lift the magnet, if it does not remain close to level, carefully lower the magnet and adjust the lifting configuration and then lift the magnet again.
6. Smoothly move the magnet through the raised opening in the exterior wall, and carefully lower so it rests on a flat surface.

Chapter 3 Magnet storage conditions, pending ramp

3.1 Connecting the magnet to the compressor

Safety	
	<p>WARNING</p> <p>POTENTIAL COLD BURN OR ASPHYXIATION HAZARD</p> <p>Gaseous helium (odorless, colorless gas) is discharged from the magnet venting activities, and can cause cold burns or asphyxiation.</p> <p>Wear protective clothing, nonabsorbent gloves, and goggles when venting the magnet. Do not go on or near the venting region.</p>
	<p>WARNING</p> <p>ELECTRIC SHOCK</p> <p>Contact with connectors leading to an energized compressor can cause electrical shock.</p> <p>Disconnect input power to the compressor and follow LOTO procedures to make sure power is not supplied to the compressor.</p>
	<p>NOTICE</p> <p>EQUIPMENT DAMAGE RISK</p> <p>Improper operation/maintenance of equipment can result in equipment damage.</p> <p>For detailed information about the operation, function, and maintenance of the coldhead and compressor, refer to the appropriate cryocooler and/or compressor vendor technical operating manual (Vendor Manuals CD33ZZ-073, CD33ZZ-080), available through the support documentation library at gehealthcare.com or your local GE HealthCare Service Representative.</p> <p>For detailed information about the operation, function, and maintenance of the Magnet Monitor, please refer to the appropriate technical operating manual (<i>Magnet Monitor 4 Operating and Service Manual</i>, 5804162), available through the support documentation library at gehealthcare.com or your local GE HealthCare Service Representative.</p>

This magnet has superconducting coils immersed in a liquid helium vessel that is surrounded by an insulating cryostat. Due to site readiness delay, sometimes it is necessary to store the magnet in its shipping configuration at a warehouse. During this storage period, the magnet cryocooler must be connected to the compressor and the Magnet Monitor system to maintain proper temperature and pressure, and minimize helium loss as well as risk for internal icing issues.



NOTE

The following instructions apply to the F50SH compressors. You can find information on other compressor models in the appropriate technical publications/operating manuals.

1. Make sure that the F50SH compressor supply static pressure is between 1.6 MPa and 1.65 MPa.

Figure 3-1 F50SH compressor unit, supply pressure

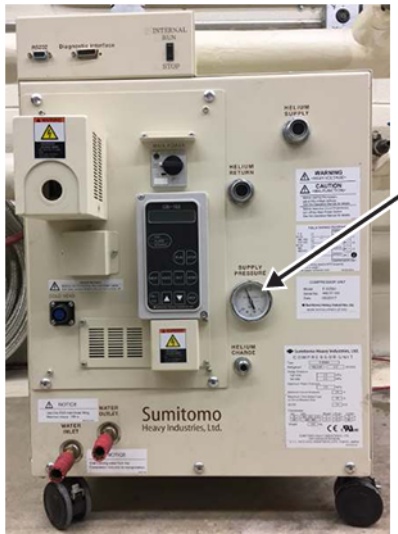

2. Make sure that the O-rings are in the coldhead supply and coldhead return line connectors.
3. Connect the cooling water for the compressor (or do a check of the connection, if already connected).
4. Make sure that the default running mode is internal. FE or warehouse staff must not change this.
5. Using two wrenches (one to hold the backside adapter connection, and one to tighten), connect the coldhead compressor lines in the following order:



NOTE

The hold wrench maintains the backside adapter connection, making gas leaks in the system less likely. Do not overtighten.

Figure 3-2 Using two wrenches to tighten a connection

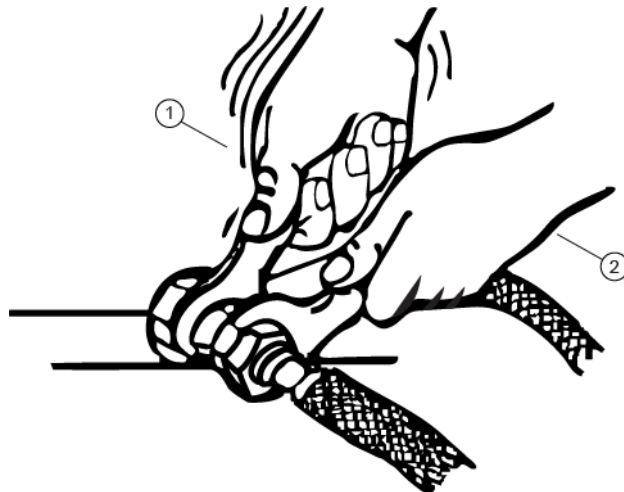

1	Tighten
2	Hold fast

**NOTE**

Do not put any bending force on Aeroquip fittings while connecting/disconnecting helium flexlines. A bending force will create difficulty in the rapid engagement/disengagement required to prevent helium loss and system contamination. Support the gas lines when connecting/disconnecting them to the compressor.

- 5.1. Attach the coldhead return line.
- 5.2. Attach the coldhead supply line.
- 5.3. Attach the coldhead power cable.

Figure 3-3 Coldhead compressor connections

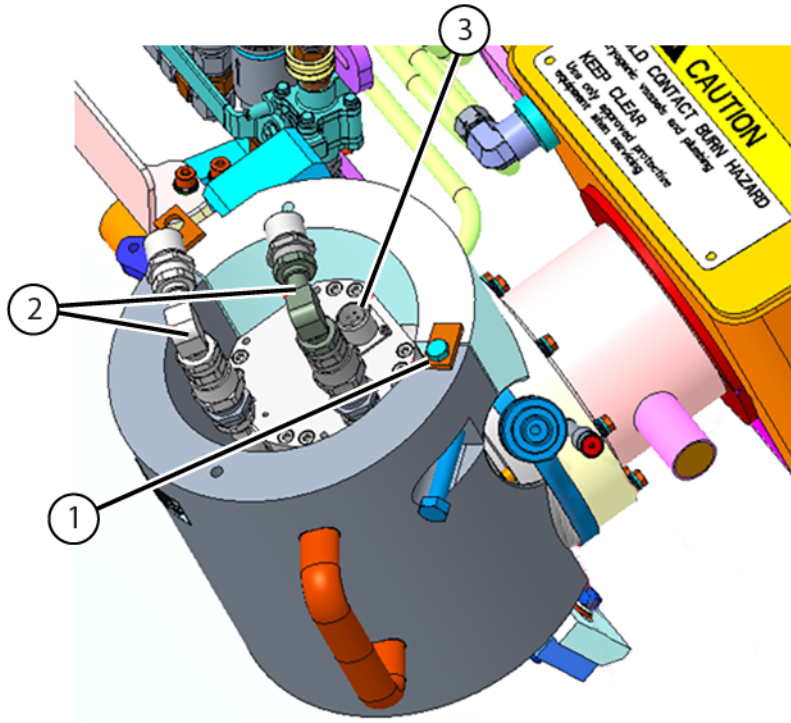

1	Motor shield pin (M8 x 16 cap screw)
2	Right-angle flexline connectors
3	Coldhead power connection

6. To turn on the compressor, complete the following substeps using switches and connections on the compressor's front panel:
 - 6.1. For new compressor installations, make sure the input power voltage is connected to the compressor. If the input power voltage is 480V at 60Hz, no change on the voltage tap setting is required. Otherwise, set up the terminal wiring, located at the voltage tap area, per the input power voltage. Refer to vendor manuals for this procedure.
 - 6.2. Make sure the Run/Stop switch on the compressor's front panel is in the RUN position.
 - 6.3. Turn on main power switch, and wait 1 to 3 seconds for the compressor to start.
 - 6.4. Do a check for warnings or alarms.

! **IMPORTANT**
Whenever the compressor shows an alarm or warning, investigate the cause and solve the problem before resetting the alarm and running the compressor.

Figure 3-4 F50SH compressor unit, front view

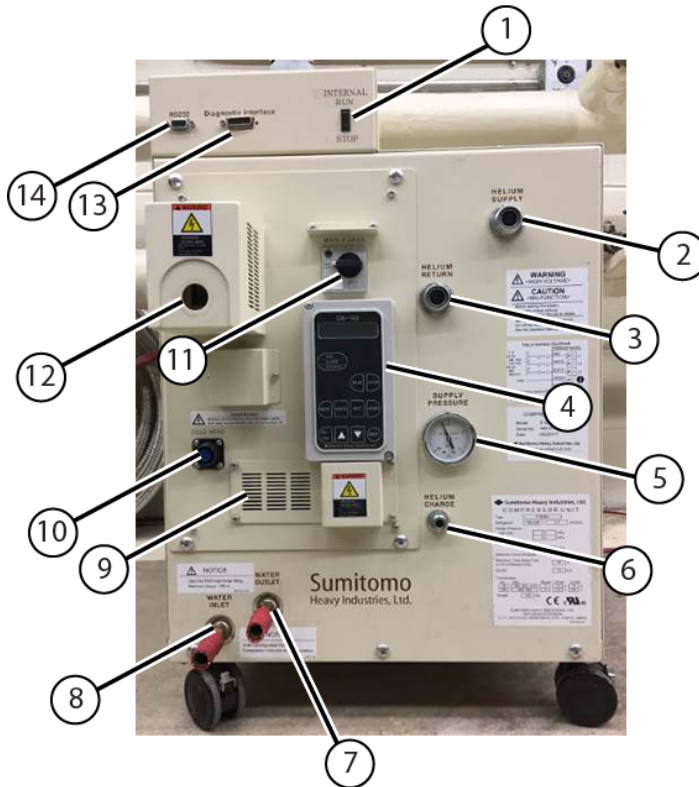

Item	Description	Item	Description
1	Run/Stop switch	8	Water inlet
2	Helium supply	9	Voltage tap
3	Helium return	10	Coldhead power line
4	Operation panel unit (OPU)	11	Main power switch
5	Pressure gauge (supply)	12	Compressor power cable
6	Helium charge port	13	Diagnostic interface (MM4)
7	Water outlet	14	RS232C (MM4)

7. To turn off the compressor, complete the following substeps using switches and connections on the compressor's front panel:
 - 7.1. Turn off main power switch.
 - 7.2. Disconnect and lockout/tagout (LOTO) input power to the compressor. Use a digital voltmeter (DVM) or equivalent measuring device to make sure that no voltage is present.
 - 7.3. To prevent contamination of gas lines and the compressor, make sure the gas lines are removed immediately after power is disconnected.

**NOTE**

Do not put any bending force on Aeroquip fittings while connecting/disconnecting helium flexlines. A bending force will create difficulty in the rapid engagement/disengagement required to prevent helium loss and system contamination. Support the gas lines when connecting/disconnecting them to the compressor.

3.2 Connecting the magnet monitoring connections

When connecting the cables, do not route the cables in a way that causes unnecessary strain or bending on the cables. Hand-tighten the screws on each connector; loose connections can cause reading errors.

1. Examine the cables used to monitor the magnet's pressure and helium level before connecting them to the magnet. Make sure that all pins are straight and almost level with the connector casing (for example, not pushed back). The cables should also not have any broken insulation. If you see any damage, get a new cable and replace the old one as soon as possible.



NOTE

Each Magnet Monitor should have a dedicated cable set, which is firmly attached to the unit. Swapping cables between different magnet monitoring units can cause early failure of the connectors.

2. Connect Cable, Run 850 MON J-2 to Compressor RS232 (5807125) from the Magnet Monitor to the compressor.
3. Attach the magnet pressure cable to the pressure transducer.

Figure 3-5 Absolute pressure transducer



4. Attach the helium level sensor cable into the LHe1 or LHe2 port (typical connection ports shown below).

Figure 3-6 Typical instrumentation connector assembly ports



5. Close the V3 valve during storage to prevent helium loss from the 15.7 psia valve.

Figure 3-7 V3 valve in the closed position

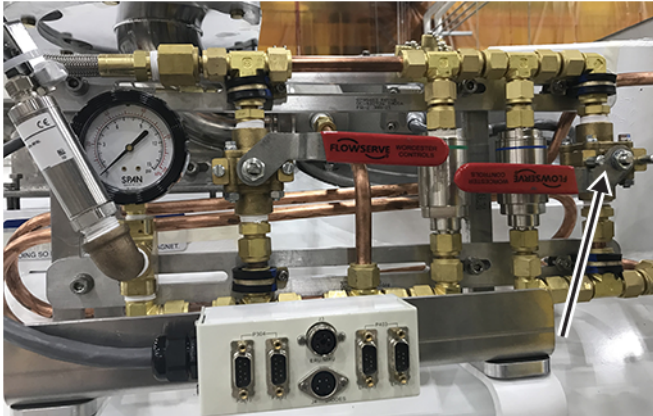

NOTE

The V3 valve must be reopened before the magnet resumes shipping.

Figure 3-8 Plumbing assembly, V3 valve in the open position

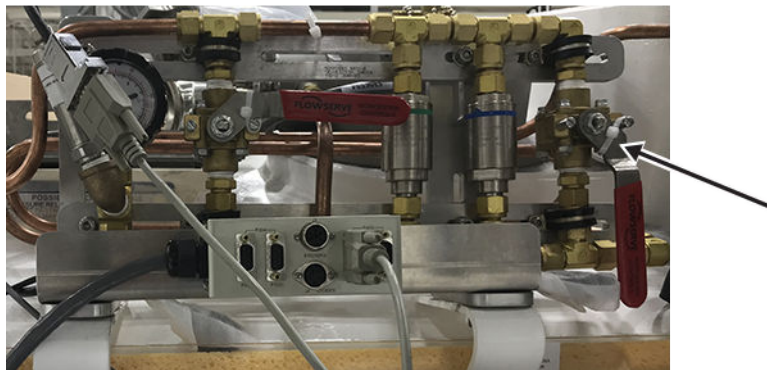

3.3 Monitoring the magnet

Using the Magnet Monitor front panel user interface, monitor the magnet pressure and helium level at least once per day to minimize loss of liquid helium and minimize internal icing situations.

The front panel of the Magnet Monitor unit is made up of the following elements:

- LEDs showing AC power, heater activity, and alarm activity
 - LCD display for user interaction
 - 16-button soft keypad
1. Press the **Home** button to change the display to usual operating mode. This mode shows the following information:

Screen	Display	
1	Date Software Revision	Title Number of Alarms
2	He Level xxxx Liters or xx.xx%	
3	He Pressure x.xxx psig	

Figure 3-9 Magnet Monitor front panel user interface, He Pressure (psig) (left) and He Level (%) (right)



2. At the time of helium level monitoring, press the **Sample** button to initiate a helium level sample.



NOTE

It can take up to 90 seconds for the display to update and show the new level(s). Helium level requirements can vary according to purchase agreements. Work with your Logistics Team and/or Field Service Contact to determine helium level requirements.

3. Monitor helium pressure from the Home screen. If the magnet fails the following conditions, contact GE HealthCare service:
 - 3.1. The expected arrival pressure should be between 0.9 and 2.0 psig.

- 3.2. The pressure setting on the Magnet Monitor should be set to 0.7 to 0.9 psig for storage. These are not the default parameters and will need to be set. Refer to the *Magnet Monitor 4 Operating and Service Manual* (5804162).

**NOTE**

Magnet Monitor 4 (MM4) can also be set to Storage mode by doing the following in order:

- Press the **Fill** mode button until the option for Storage mode prompts yes/no.
- Select **yes**.

Storage mode holds the magnet pressure at 0.8 psi until MM4 reboots (about once every 2 weeks). When MM4 reboots, it will exit Storage mode and this setting will need to be reconfigured.

- 3.3. The helium level should never drop more than 5% (approximately 100L) below the arrival level.
- 3.4. The pressure should never be less than 0.7 psig.

Page intentionally left blank

Chapter 4 Doing in-transit service and magnet system checks

4.1 Preparing to do an in-transit helium refill

Safety

NOTICE

EQUIPMENT DAMAGE RISK

Improper transportation can result in damage to the magnet.

Before you continue with an in-transit helium fill, make sure the shipping crate is removed from the magnet (see [2.7 Removing the shipping crate on page 25](#)).

In-transit service and magnet electrical checks must be done by qualified personnel only and in strict conformance with the *Doing a liquid helium fill* procedure stated in the appropriate manual:

- *Magnet and Cryogen Manual for 3.0T AR Series Magnets* (5871810-8EN)
- *MR Service Safety Manual* (5452735)

These documents are available through the support documentation library at gehealthcare.com or your local GE HealthCare Service Representative.

The images below show in-transit plumbing configuration examples.



NOTE

Magnet images shown are representative. Actual magnet configuration may vary.

Figure 4-1 Plumbing assembly, V3 valve in the open position

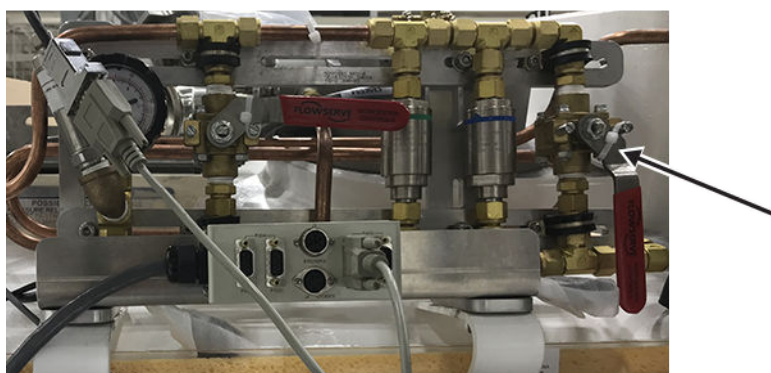

Figure 4-2 Vent adapter replaced with international shipping plate assembly

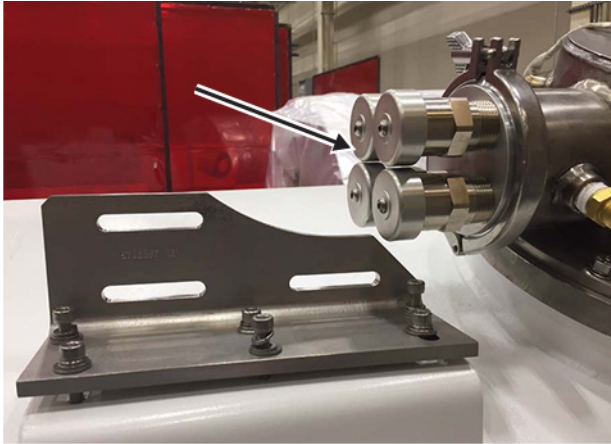
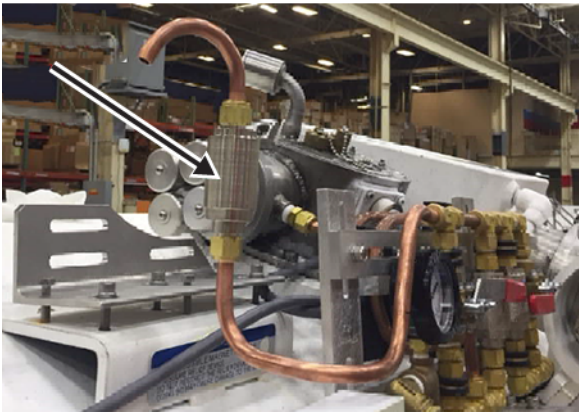

Figure 4-3 15.7 PSIA valve assembly



4.2 Doing a magnet system check

Safety

NOTICE

EQUIPMENT DAMAGE RISK

Improper transportation can result in damage to the magnet.

In-transit service and magnet electrical checks must be done by qualified personnel only, after the magnet is sited and in strict conformance with the *Doing a liquid helium fill* procedure stated in the appropriate manual:

- *Magnet and Cryogen Manual for 3.0T AR Series Magnets (5871810-8EN)*
- *MR Service Safety Manual (5452735)*

These documents are available through the support documentation library at gehealthcare.com or your local GE HealthCare Service Representative.



NOTE

Magnet system checks are a physical inspection done by GE HealthCare Service.

1. Locate the Pre-Delivery Information Package shipped with the magnet. It contains the Bill of Material for the magnet system delivered.
2. Make sure that all boxes indicated on the Bill of Material are included.
3. Make sure that the contents of each box matches its packing list when the boxes are brought into the MR site.
4. Inspect the magnet for physical damage and icing/condensation on the body, and do one of the following:
 - If no problems are found, unload the magnet.
 - If there is damage, report the damage in conformance with the procedure [1.2 Examining packages for damage in transportation on page 11](#). Report all problems found to the regional Magnet & Cryogenics (MAC) Team Leader.
5. If there is icing or condensation on the exterior or the bore of the magnet, check the liquid helium level before unloading. Refer to the Installation and Adjustment section's "Installing the Magnet Monitor" procedure in the *Magnet and Cryogen Manual for 3.0T AR Series Magnets (5871810-8EN)*.



NOTE

If the magnet has been sitting for a period of time with the coldhead inoperative, the magnet may be depleted of cryogen. Contact the logistics or field service team for further directions.

Page intentionally left blank

Chapter 5 Preparing the scan room

1. Remove any debris from the magnet room floor where the mats will be put in position.
2. Make sure that there are no RF seams under the vibroacoustic damping mats.
3. Move the vibroacoustic damping mats to the MR suite.



NOTE

The vibroacoustic damping mats may arrive in a cold state preventing compression. Put the vibroacoustic damping mats in the magnet room prior to moving the magnet to the MR suite to let their temperature stabilize.

5.1 Preparing the scan room for leveling an AR series magnet

Tools and test equipment			
Item	Quantity	Part number	Manufacturer
PH Alignment and Magnet Leveling Kit	1	5897979	-

PH Alignment and Magnet Leveling Kit (5897979)			
Item	Quantity	Part number	Manufacturer
Laser Level PLS 180R Z	2	5831466	-
Tripod, Vanguard Alta Pro 263AB 100	2	5829559	-
Folding Ruler, 2 meters, FM-DELA.401.00	1	5897974	-
PM Series Magnet Template	1	5810898	-

1. Make sure that markings are present on the magnet room floor in either of the following locations.
 - Magnet geometric isocenter location and z-axis vector (longitudinally through the bore).

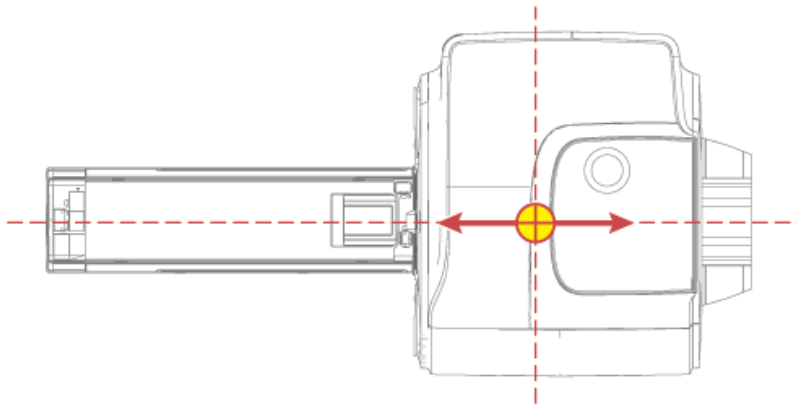
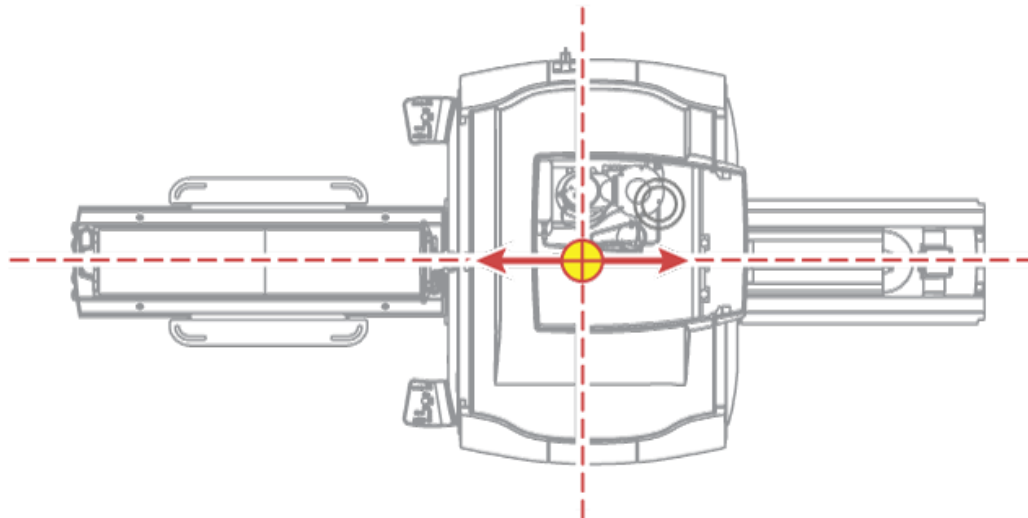
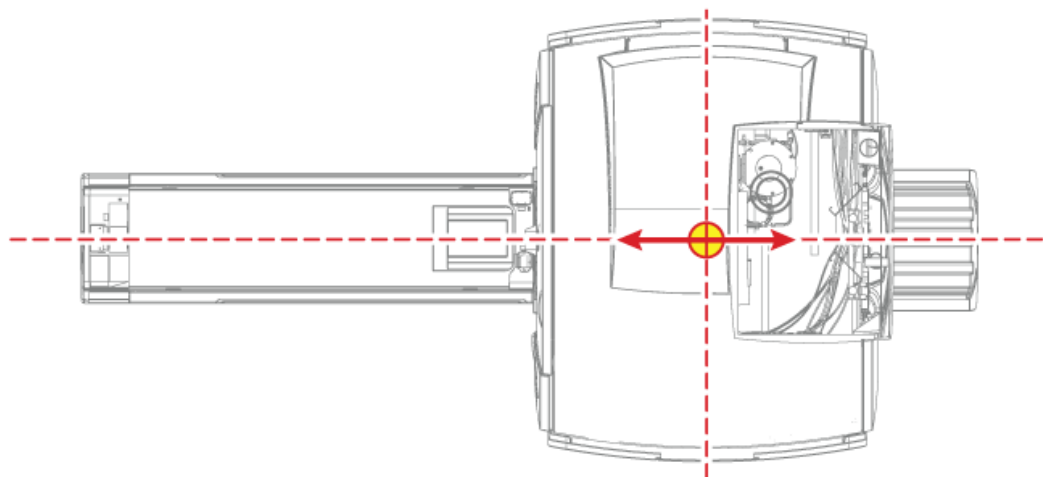
Figure 5-1 Isocenter location and z-axis vector, SIGNA Hero and SIGNA Premier**Figure 5-2 Isocenter location and z-axis vector, SIGNA Architect and SIGNA PET/MR****Figure 5-3 Isocenter location and z-axis vector, SIGNA Pioneer**

- Magnet geometric isocenter location and center of vent pipe.

Figure 5-4 Isocenter location and vent pipe location, SIGNA Hero and SIGNA Premier

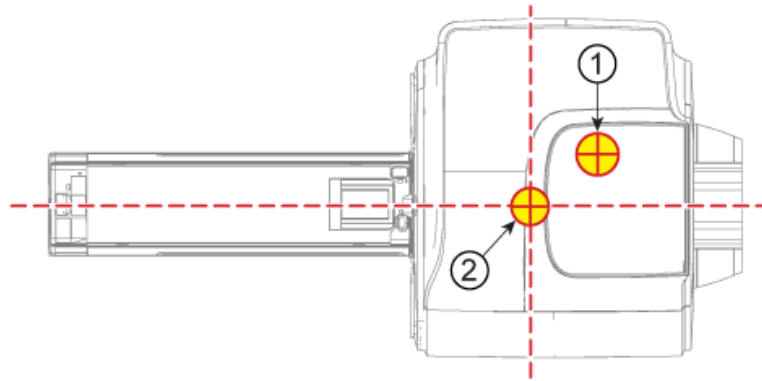

Figure 5-5 Isocenter location and vent pipe location, SIGNA Architect and SIGNA PET/MR

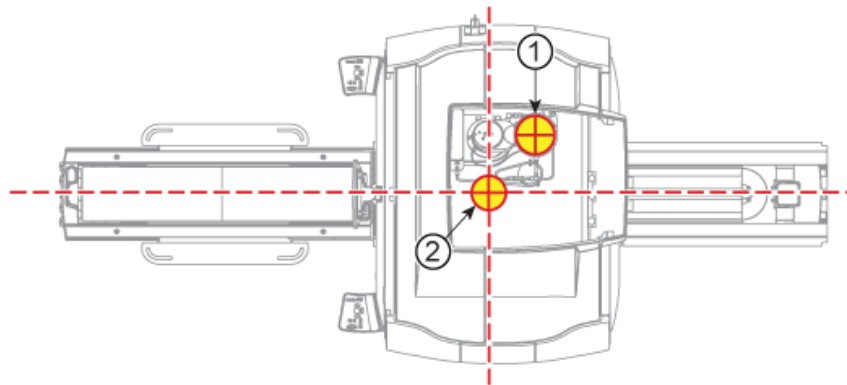
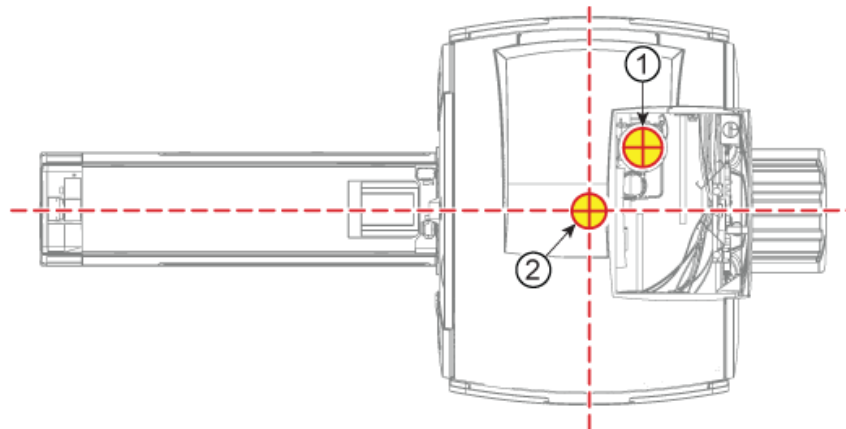

Figure 5-6 Isocenter location and vent pipe location, SIGNA Pioneer



1	Vent center
2	Magnet isocenter

2. If needed, transcribe the marks from the ceiling to the floor with tape from the kit, using laser levels as needed.

3. Align the positioning template (5810898 or 5810898-2) in accordance to the markings, using one of the following strategies:
 - Align the centerline of the positioning template with the marked z-axis vector.
 - Align the template to magnet isocenter and vent stack location.

Figure 5-7 Positioning template (5810898)

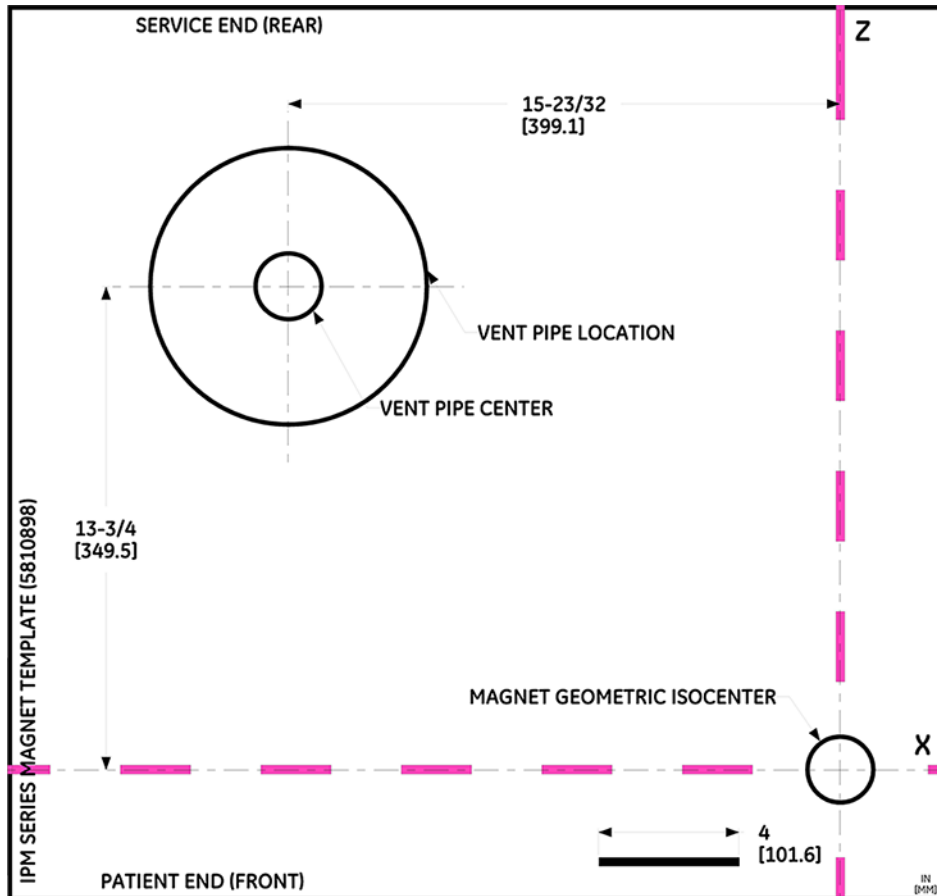

- Use tape from the kit to secure the positioning template to the floor.

Figure 5-8 Securing the positioning template to the floor

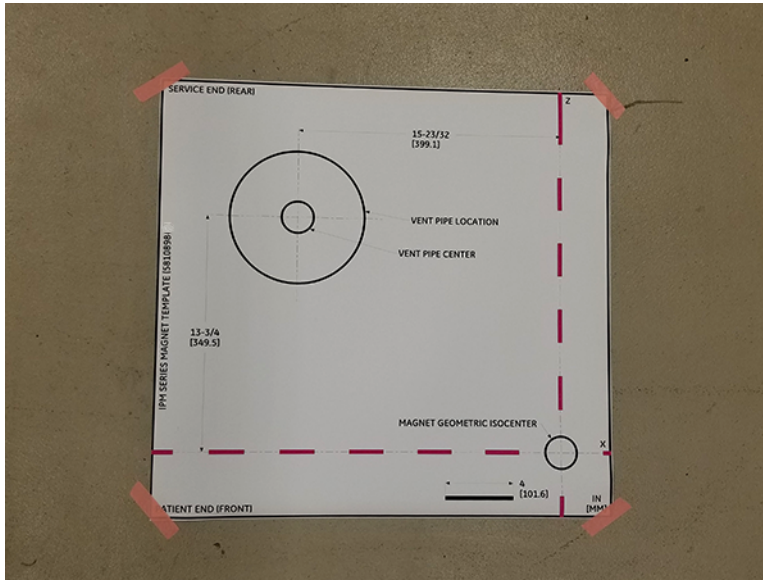

- Make sure the first laser level from the kit is in self-leveling mode.



NOTE

In self-leveling mode, if the laser level tilts $> 4^\circ$ in any direction, the lasers do not show. When the laser level tilt is $\leq 4^\circ$, the level indicator LED is green and the lasers show.

Figure 5-9 Laser level in self-leveling mode (unlocked position)



- Put the first laser level on a tripod in the front of the room.
- Put the folding ruler from the kit vertically near the front center of the planned magnet location.

- Adjust the tripod height until the horizontal laser line aligns on the ruler approximately 1070 mm (42.13 inches) from the floor. Accuracy is not critical here.

Figure 5-10 Magnet isocenter height

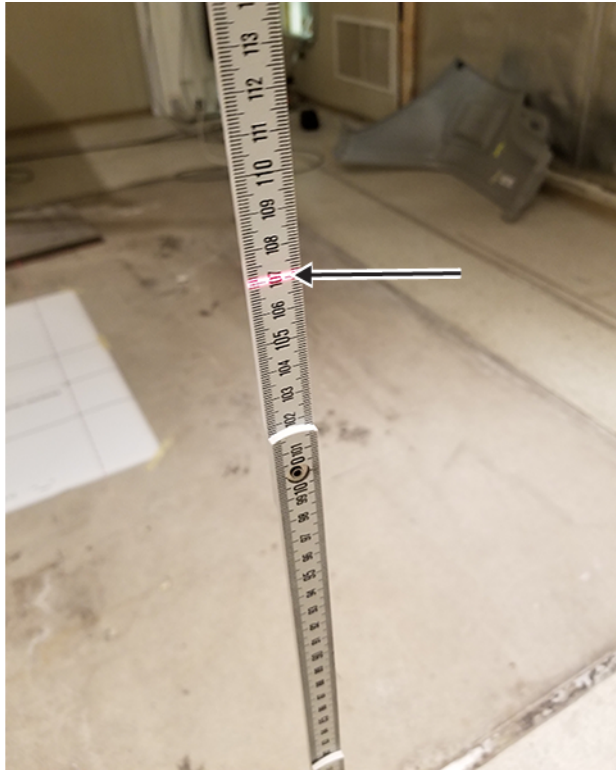

The laser line passes through the isocenter along the z-axis vector.

9. Mark at least two reference locations - one close to the laser and one far away - on the floor, wall, or ceiling. Do **not** mark any references on the floor where the magnet will be set. Make sure that the reference marks will still be within sight of the laser when the magnet is in position.

Figure 5-11 First laser reference marks

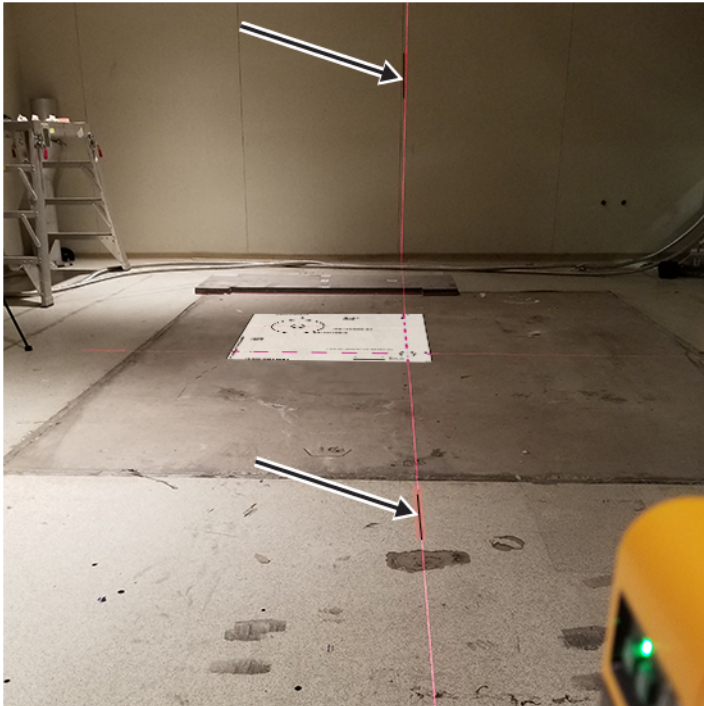

The reference marks will help you realign the laser level in the event of an accidental movement during the magnet installation.

10. Make sure the second laser level from the kit is in self-leveling mode.



NOTE

In self-leveling mode, if the laser level tilts $> 4^\circ$ in any direction, the lasers do not show. When the laser level tilt is $\leq 4^\circ$, the level indicator LED is green and the lasers show.

Figure 5-12 Laser level in self-leveling mode (unlocked position)



11. Put the second laser level on a tripod on the left side of the room (electronics side of the magnet).

- Adjust the second laser level until the vertical laser line passes through the lateral (x-dir) centerline axis on the template and will be visible on the magnet's cryogen plenum when in position.

Figure 5-13 Laser line in the center of the cryogen plenum rib

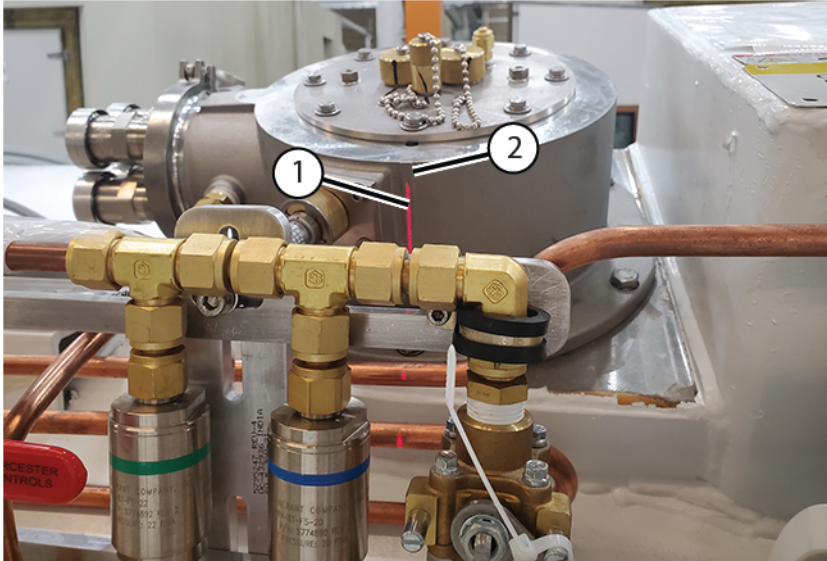

1	Laser line
2	Cryogen plenum rib

13. Mark at least two reference locations - one close to the laser and one far away - on the floor, wall, or ceiling. Do **not** mark any references on the floor where the magnet will be set. Make sure that the reference marks will still be within sight of the laser when the magnet is in position.

Figure 5-14 Second laser reference marks



The reference marks will help you realign the laser level in the event of an accidental movement during the magnet installation.

14. Remove the template from the floor.
15. Continue to the appropriate chapter based on your type of installation.

Installation type	Next steps
Nonseismic	Chapter 6 Installing a nonseismic vibroacoustic damping mat and leveling the magnet on page 63
Seismic	Chapter 7 Installing a seismic vibroacoustic damping mat and leveling the magnet on page 81

Page intentionally left blank

Chapter 6 Installing a nonseismic vibroacoustic damping mat and leveling the magnet

Safety
<p>NOTICE</p> <p>EQUIPMENT DAMAGE RISK</p> <p>Improper damping mat installation can result in damage to the magnet.</p> <p>Tasks in this section must be completed by riggers, not GE HealthCare Service Personnel.</p>

6.1 Equipment overview

Tools and test equipment			
Item	Quantity	Part number	Manufacturer
PH Alignment and Magnet Leveling Kit	1	5897979	-
Tape Measure	1	-	-
Magnet Leveling Shim Kit	2	5819317	-
Vibromat Assembly, Platform	4	5802910	-

PH Alignment and Magnet Leveling Kit (5897979)			
Item	Quantity	Part number	Manufacturer
Laser Level PLS 180R Z	2	5831466	-
Tripod, Vanguard Alta Pro 263AB 100	2	5829559	-
Folding Ruler, 2 meters, FM-DELA.401.00	1	5897974	-
PM Series Magnet Template	1	5810898	-

Magnet Leveling Shim Kit (5819317)			
Item	Quantity	Part number	Manufacturer
Shim Plate, 0.5 mm Thick	8	5872197-05	-
Shim Plate, 1.5 mm Thick	8	5872197-15	-
Shim Plate, 3.0 mm Thick	4	5872197-30	-

Required conditions
Magnet and dock installation and placement are critical to image quality and hardware reliability.

6.2 Putting a nonseismic mounted vibroacoustic damping mat into position

1. Make sure that the vibroacoustic kit contains the parts listed in the following table.

Table 6-1 Vibroacoustic damping mat kit (5802910)

Quantity	Part number	Description
4	5802910	Vibromat Assembly, Platform

2. Put the vibroacoustic damping mats on the floor, in the appropriate location where the magnet will be set.

Figure 6-1 Vibroacoustic damping mat (5802910), side view



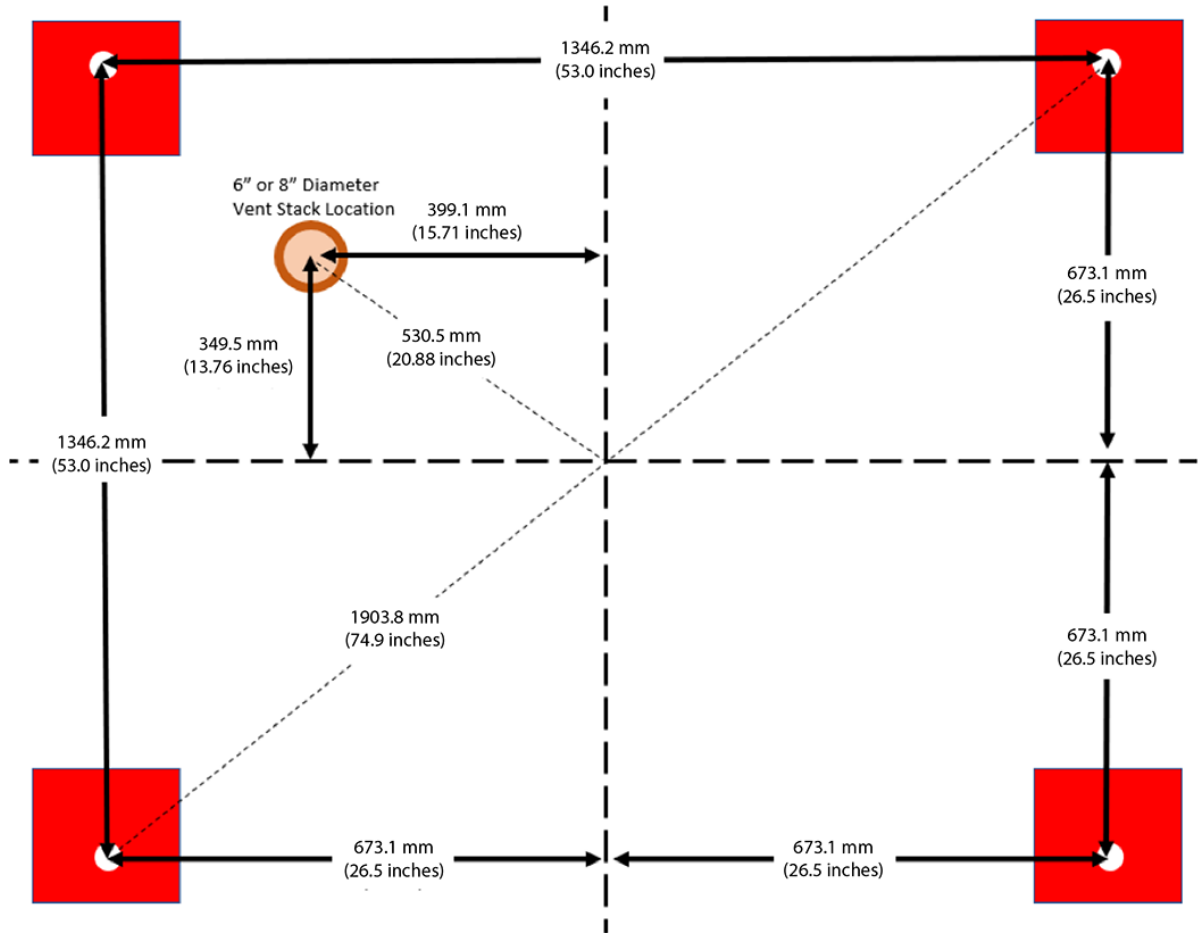

1	Aluminum
2	Red pad

Figure 6-2 Vibroacoustic mat placement (patient end is at the bottom)



6.3 Preparing to move the magnet

Safety	
	<p>DANGER</p> <p>POTENTIAL ASPHYXIATION HAZARD</p> <p>Loss of magnet vacuum will result in the rapid expulsion of helium gas, which can cause asphyxiation in enclosed areas.</p> <p>Make sure that hospital personnel are aware of this situation prior to the magnet being moved within the enclosed areas. Use extreme caution and do not contact or damage the vacuum vessel during magnet transit or siting.</p>
	<p>WARNING</p> <p>POTENTIAL INJURY HAZARD</p> <p>Moving the magnet improperly will cause personal injury or magnet damage.</p> <p>See Chapter 2 Unloading and moving the magnet on page 17 before moving the magnet using a forklift or crane.</p>

Safety**NOTICE****EQUIPMENT DAMAGE RISK**

Improper transportation can result in damage to the magnet.

Tasks in this section are to be done by riggers, not by GE HealthCare Personnel.

Do not apply any force to the magnet's enclosures.

Any floor anchors that are used to move the magnet must not penetrate the RF shield.

Magnet and dock installation and placement are critical to image quality and hardware reliability. The magnet must be installed level with the isocenter to the specifications listed in this chapter.

After the magnet is moved to the building using a crane or forklift (see [Chapter 2 Unloading and moving the magnet on page 17](#)), it needs to be moved to the magnet room. There are many methods to help move the magnet, including the use of a motorized tow vehicle, a come-along, or a chain jack. When you are moving the magnet, make sure that you are moving it in a smooth, controlled manner.

**NOTE**

Remove the lifting rails and bubble wrap at any point forward when the process allows, and you are done using the rails. When removing the bubble wrap, do not nick or cut any electrical cables.

WARNING**RISK OF DEATH, PERSONAL INJURY, OR EQUIPMENT DAMAGE**

Used and/or damaged lifting rail bolts, lock washers, flat washers, and nuts can cause equipment and/or component damage, death, or serious physical injury!

Discard the used lifting rail hardware after it is removed from the magnet. This hardware must only be used one time. If lifting rails are to be reinstalled, use new, undamaged bolts, lock washers, flat washers, and nuts, which are available as FRUs that can be ordered from GE HealthCare.

1. Optionally, roller dollies are recommended for moving the magnet inside a building. If you use roller dollies, put steel floor plates along the magnet delivery route.

Figure 6-3 Magnet on roller dollies

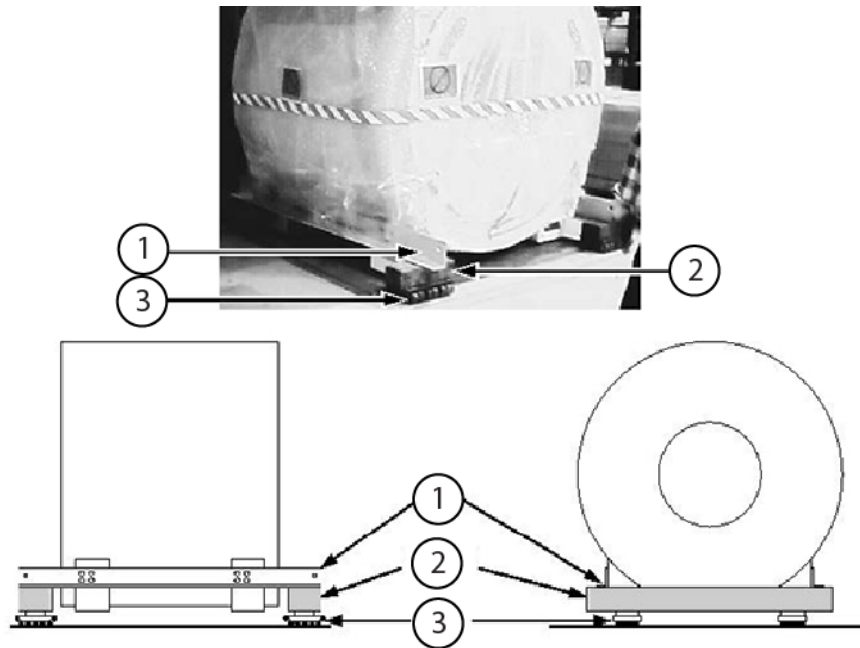

1	Lifting rails
2	100 mm x 150 mm (4 inch x 6 inch) wood beams
3	Roller dollies

2. Have the rigger make sure that walls, floors, and so on along the transportation route are protected from potential damage.
3. Attach any cables, chains, or straps used for moving the magnet to the orange lifting rails.
4. Make sure that the magnet front-rear orientation is relative to the magnet room's front and rear.
5. Do a check of all clearances along the route that the magnet will move to get to the magnet room. Compare those clearances with the appropriate illustration below.



NOTE

Magnet image is shown for reference and may differ from the configuration shipped. The dimensions indicated are for the condition as shipped.



NOTE

Dimensions referenced are worst-case scenarios.

Figure 6-4 Clearance dimensions, magnet patient end as-shipped condition

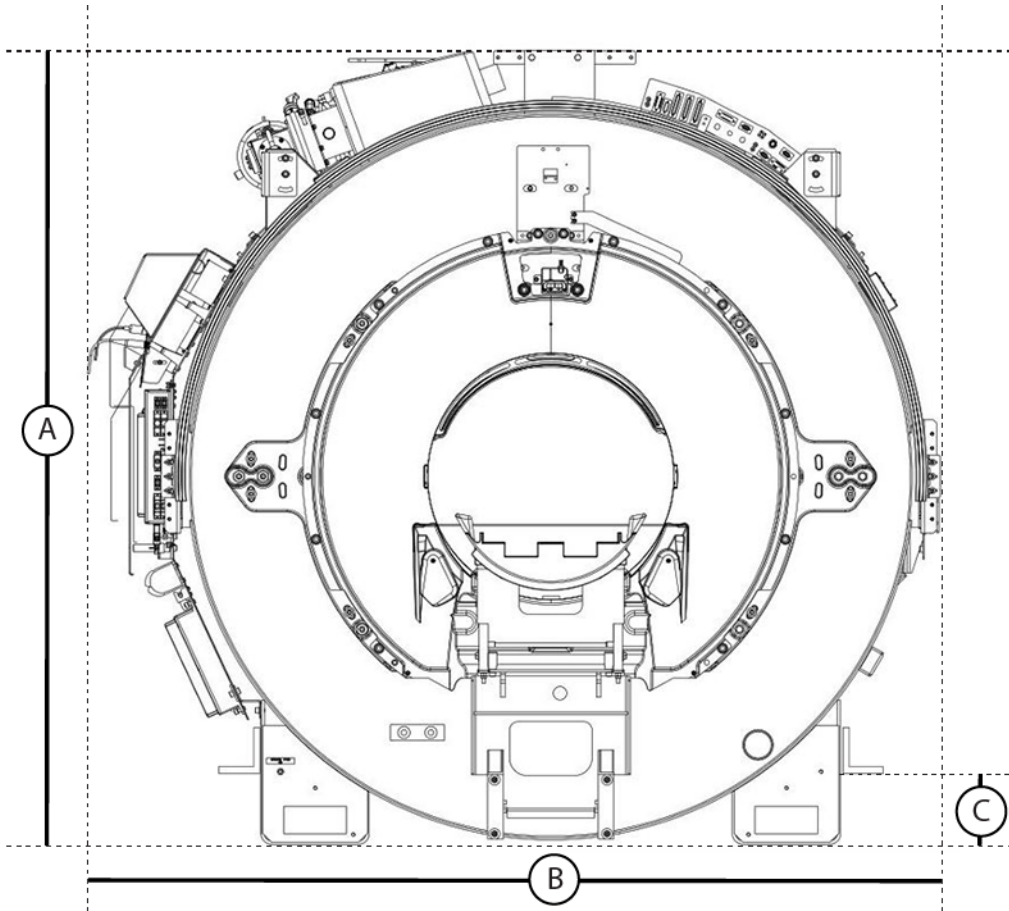

Maximum dimension	AR series magnet
A	2250 mm (88.58 inches)
B	2311 mm (90.98 inches)
C	194 mm (7.64 inches)

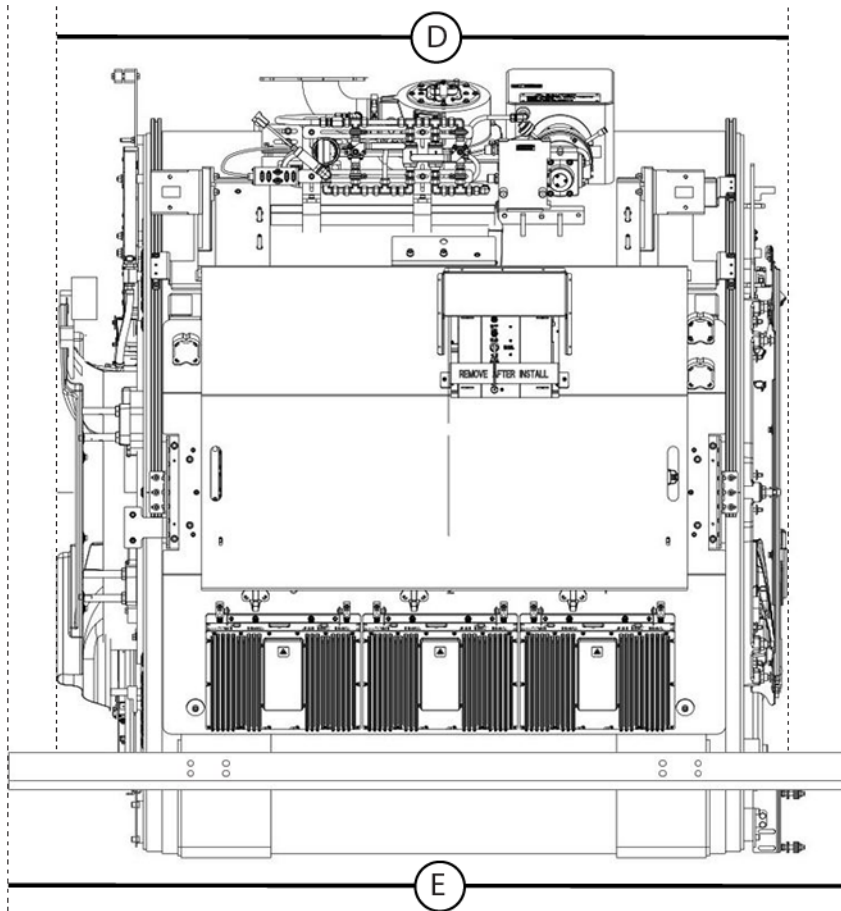
Figure 6-5 Clearance dimensions, magnet service side as-shipped condition

Maximum dimension	AR series magnet
D	2140 mm (84.30 inches)
E	2388 mm (94.00 inches)

The actual dimension could be less than or equal to the maximum dimension. Refer to the appropriate Preinstallation Manual (see [Appendix B Preinstallation Manual reference on page 109](#)). Only dimensions B and D are variable based on system type.

6. Compare the dimensions of the magnet on the moving fixtures being used with the clearances measured along the magnet delivery route. The height can be reduced by putting the moving fixtures directly under the lifting rails.

6.4 Moving the magnet into the MR suite

Safety	
	<p>CAUTION</p> <p>POTENTIAL PERSONAL INJURY</p> <p>Uneven jacking of the magnet's corners could result in the magnet shifting on the jacks, which may lead to personal injury or magnet damage.</p> <p>Keep the magnet level at all times during any jacking operation.</p>
	<p>NOTICE</p> <p>EQUIPMENT DAMAGE RISK</p> <p>Improper loads on enclosure cover parts can result in damage to the enclosure.</p> <p>Do not apply any loads to enclosure cover parts.</p> <p>Do not allow straps, cables, or chains to scrape enclosure cover parts.</p>

1. If raising the magnet is required, the lifting portion of the jack must be fully below the lifting rails.
2. Avoid tilting or rotating the magnet while moving it into the MR suite.
3. From the magnet room entrance to the magnet's final position, put steel floor plates as needed to protect the magnet room floor. The rigger must take actions necessary to ensure that walls, floors, and so on along the transportation route/path are protected from potential damage.
4. Move the magnet to the magnet room. (If using a motorized tow vehicle, attach cables, chains, or straps to the magnet's lifting rails with shackles.)
5. Make sure that there is adequate distance between the service side of the magnet and the magnet room wall as specified in the appropriate *Preinstallation Manual* (see [Appendix B Preinstallation Manual reference on page 109](#)).

6.5 Centering an AR series magnet in the MR suite

1. Make sure the laser levels are still in position and activated. If they are not, see [Chapter 5 Preparing the scan room on page 53](#).
2. Carefully cut out the bubble wrap or plastic from the bore opening on the front and rear of the magnet to provide a clear view of the six leveling targets.



NOTE

When cutting off the bubble wrap, do not nick or cut any electrical cables.

3. Make sure the laser levels are in self-leveling mode.



NOTE

In self-leveling mode, if the laser level tilts $> 4^\circ$ in any direction, the lasers do not show. When the laser level tilt is $\leq 4^\circ$, the level indicator LED is green and the lasers show.

Figure 6-6 Laser level in self-leveling mode (unlocked position)

4. Do a check of the magnet left-to-right alignment relative to the 12 o'clock leveling markers at both ends of the body coil.

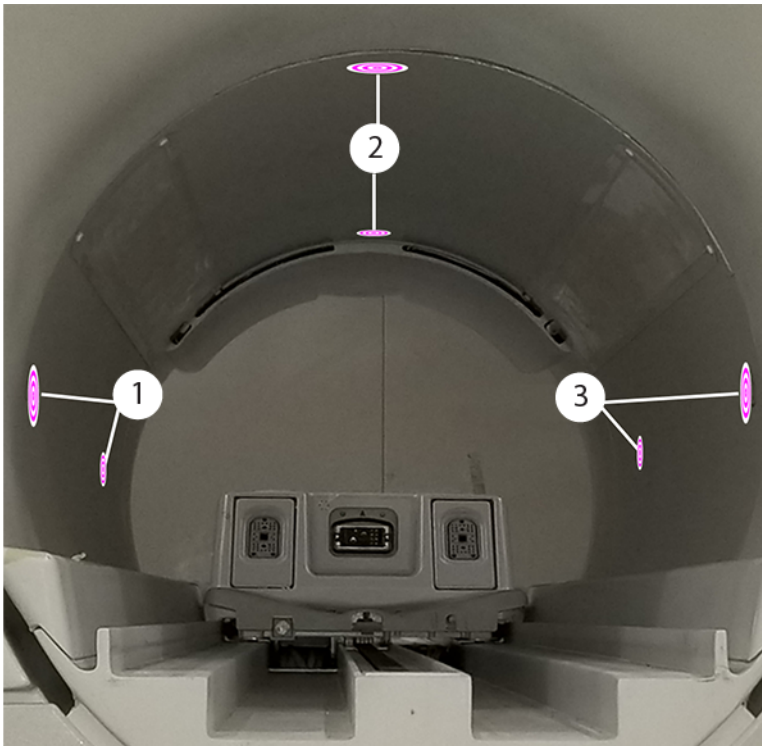
Figure 6-7 Leveling marker positions

1	9 o'clock
2	12 o'clock
3	3 o'clock

5. Make sure the projected laser line completely covers the primary target circle on the two leveling targets.

Figure 6-8 Parts of a leveling target

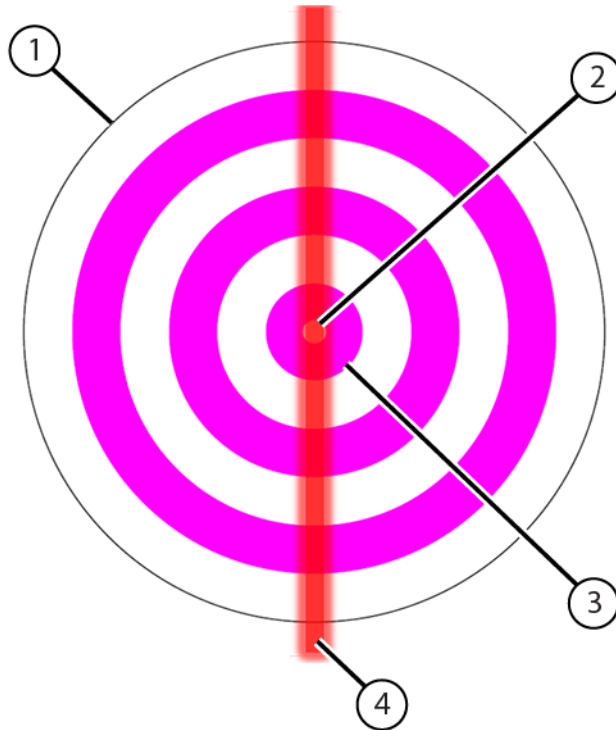

1	Leveling marker
2	Primary target circle, Ø 1.5 mm (0.06 inches)
3	Secondary target circle, Ø 6.4 mm (0.25 inches)
4	Projected laser line



NOTE

This figure is not to scale.

- Adjust the magnet position front-to-back until the laser line appears on the center of the rib of the cryogen plenum.

Figure 6-9 Laser line in the center of the cryogen plenum rib

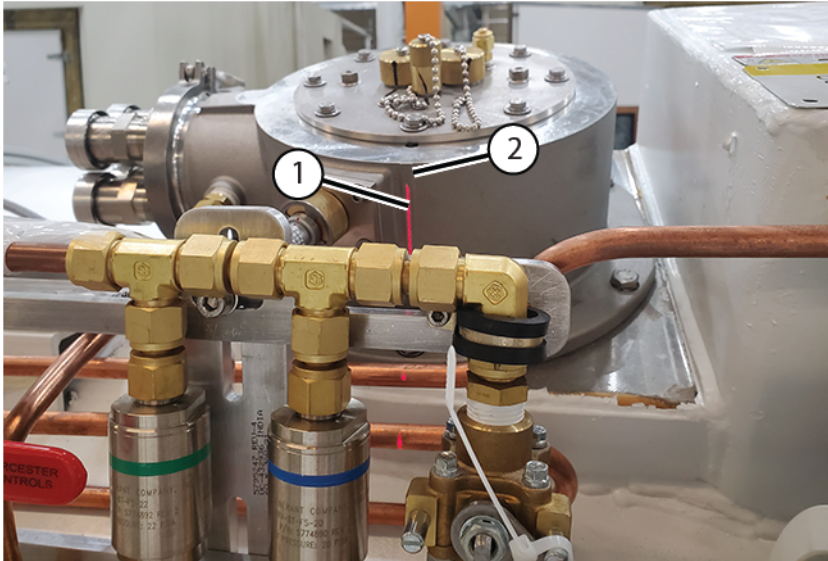

1	Laser line
2	Cryogen plenum rib

6.6 Lowering the magnet into position

1. Cut open and remove enough of the bubble wrap to allow access to the feet and for leveling operations.



NOTE

When cutting off the bubble wrap, do not nick or cut any electrical cables.

2. Align the holes in the magnet feet to the anchor holes in the vibroacoustic damping mats.
3. Make sure that the four holes, one per each magnet foot, align centered ± 3 mm (± 0.125 inches) over the anchor stud holes in the vibroacoustic damping mats.
4. Jack the magnet up sufficiently at the two lifting rails (four corners), and remove the moving fixtures.
5. Put the vibroacoustic mats below the magnet feet.
6. Slowly lower the magnet onto the vibroacoustic mats.

Figure 6-10 Lowering the magnet onto the vibroacoustic damping mats



7. Release pressure simultaneously in both jacks on one end of the magnet until that end is 25 to 50 mm (1 to 2 inches) lower than the opposite end.
8. Simultaneously lower both jacks on the other end 25 to 50 mm (1 to 2 inches).
9. Repeat lowering the magnet end to end until all feet are on the vibroacoustic mats.

6.7 Adding leveling shims

Review this section before you begin to level the magnet. If, while leveling the magnet, you need to insert shims under a magnet foot to achieve correct leveling, this section provides instructions for raising any one of the four magnet feet and properly placing shims with respect to the specific vibroacoustic mat.

1. Use a jack to raise the lowest magnet foot.
2. Insert the appropriate thickness of aluminum shim plates under the low magnet foot.

- Put the shims on the floor, under the vibroacoustic mat, making sure the surface is solid and can support the magnet weight.

Figure 6-11 Shim arrangement

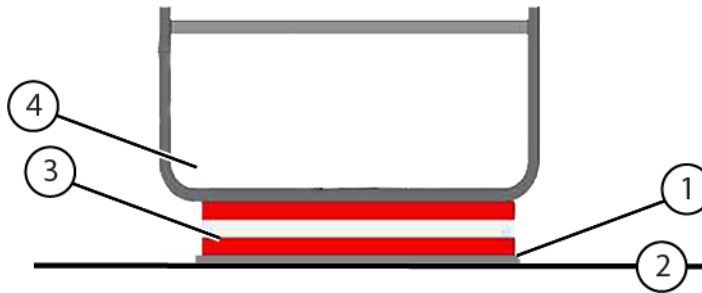

1	Leveling shims
2	Floor surface
3	Vibroacoustic mat
4	Magnet foot

6.8 Leveling an AR series magnet

- Make sure the laser level is in self-leveling mode.



NOTE

In self-leveling mode, if the laser level tilts $> 4^\circ$ in any direction, the lasers do not show. When the laser level tilt is $\leq 4^\circ$, the level indicator LED is green and the lasers show.

Figure 6-12 Laser level in self-leveling mode (unlocked position)



2. Set the laser level height to the center of the highest of the four side targets (3 o'clock and 9 o'clock leveling markers).

Figure 6-13 Leveling marker positions

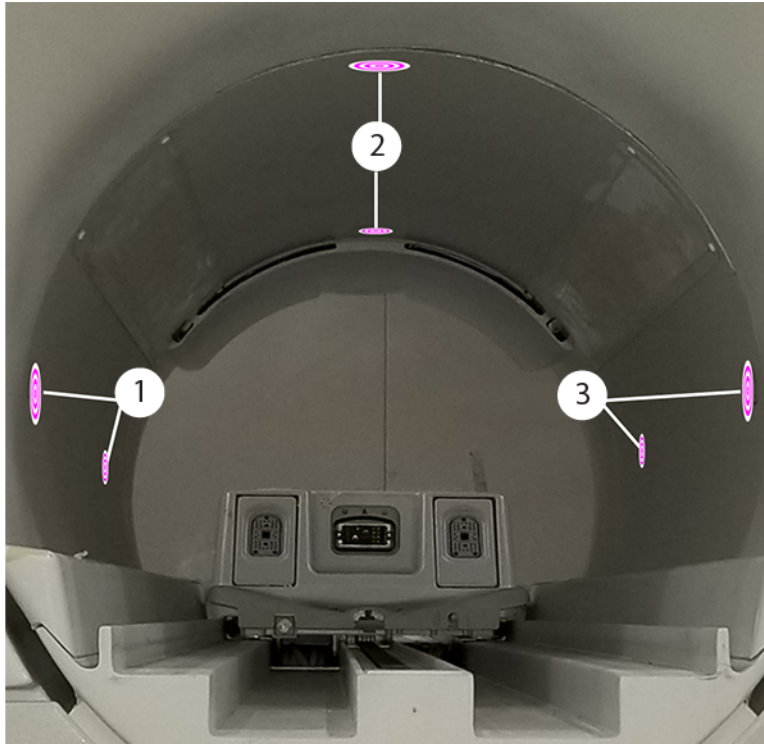

1	9 o'clock
2	12 o'clock
3	3 o'clock

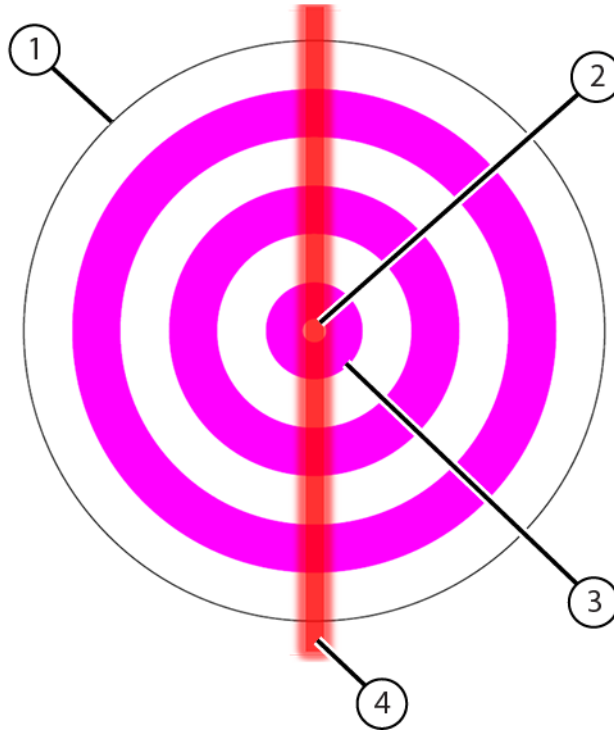
Figure 6-14 Parts of a leveling target

1	Leveling marker
2	Primary target circle, Ø 1.5 mm (0.06 inches)
3	Secondary target circle, Ø 6.4 mm (0.25 inches)
4	Projected laser line

**NOTE**

This figure is not to scale.

- Complete the following substeps to check front-to-back (superior to inferior) levelness:

**NOTE**

Measure front-to-back leveling relative to the 3 o'clock and 9 o'clock leveling markers at both ends of the body coil.

- Make sure the projected laser line completely covers the primary target circle on the leveling target.
- Add leveling shims under the vibroacoustic damping mat at each magnet foot, per the [6.7 Adding leveling shims on page 74](#) procedure, to achieve the correct front-to-back levelness based on the laser line positions and shim requirements shown below.

**NOTE**

If you need to open a second box of shims, check the floor levelness or contact Florence.

Figure 6-15 Laser line positions on a leveling target

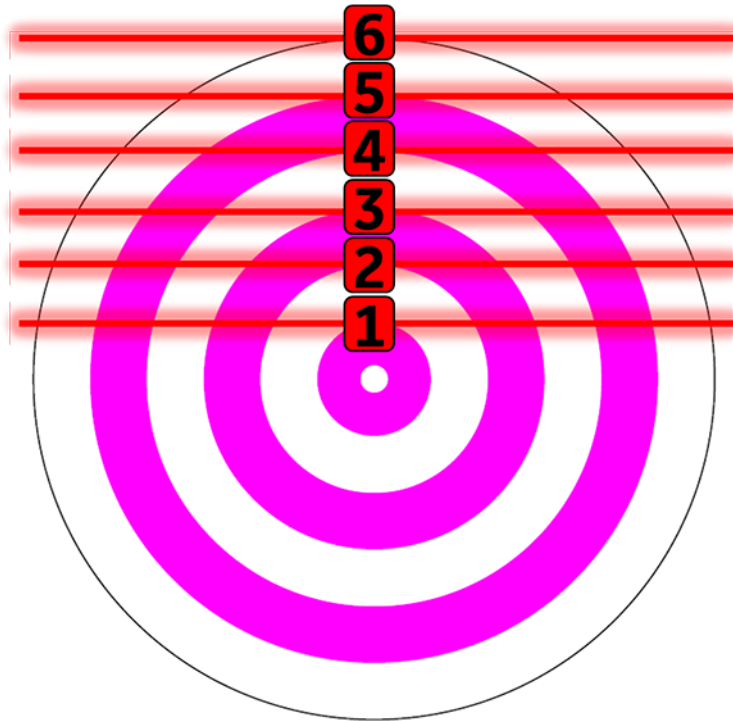

Table 6-2 Laser line shim requirements (front-to-back)

Laser line position	How far magnet foot needs to be raised (mm)	Number of 3 mm shims	Number of 1.5 mm shims	Number of 0.5 mm shims
1	3.5	1	0	1
2	6.9	2	0	2
3	10.4	3	1	0
4	13.9	4	1	1
5	17.3	5	1	2
6	20.8	Check floor levelness		

4. Complete the following substeps to check left-to-right levelness:

NOTE

Measure left-to-right leveling relative to the 3 o'clock and 9 o'clock leveling markers at both ends of the body coil.

- 4.1. Make sure the projected laser line completely covers the primary target circle on the leveling target.
- 4.2. Add leveling shims under the vibroacoustic damping mat at each magnet foot, per the [6.7 Adding leveling shims on page 74](#) procedure, to achieve the correct left-to-right levelness based on the laser line positions and shim requirements shown below.

NOTE

If you need to open a second box of shims, check the floor levelness or contact Florence.

Table 6-3 Laser line shim requirements (left-to-right)

Laser line position	How far magnet foot needs to be raised (mm)	Number of 3 mm shims	Number of 1.5 mm shims	Number of 0.5 mm shims
1	4.2	1	0	2
2	8.4	2	1	2
3	12.6	4	0	1
4	16.7	5	1	0
5	20.9	Check floor levelness		

5. Complete the following substeps to check magnet height:

**NOTE**

Measure height leveling relative to the 3 o'clock and 9 o'clock leveling markers at both ends of the body coil.

- 5.1. Make sure the projected laser line completely covers the primary target circle on the leveling target.
- 5.2. Make sure the horizontal laser line from the front laser level still aligns 1070 mm (42.13 inches) from the floor at the front of the magnet. Accuracy is critical here.
- 5.3. If necessary, put a folding ruler in position vertically near the front center of the magnet, and adjust the tripod height until the horizontal laser line aligns on the ruler 1070 mm (42.13 inches) from the floor (the magnet isocenter should be 1064 to 1076 mm). Compare the laser position to the targets inside the body coil.
- 5.4. Add leveling shims under the vibroacoustic damping mat at each magnet foot, per the [6.7 Adding leveling shims on page 74](#) procedure, to achieve the correct height based on the laser line positions and shim requirements shown below.

**NOTE**

If you need to open a second box of shims, check the floor levelness or contact Florence.

Table 6-4 Laser line shim requirements (height)

Laser line position	How far magnet foot needs to be raised (mm)	Number of 3 mm shims	Number of 1.5 mm shims	Number of 0.5 mm shims
1	3.2	1	0	0
2	6.4	2	0	1
3	9.6	3	0	1
4	12.8	4	0	2
5	16.0	5	0	2

6. Some of the leveling markers may no longer fit in the primary target circle on the leveling target. **For acceptability, at least three of the four side leveling markers must be completely covered by the primary target circle. The remaining marker must have complete coverage in the secondary target circle. (For seismic installations, the markers in the 12 o'clock position are not used.)**

7. Test-fit the cryogen vent stack to make sure it aligns with the scan room vent pipe.
8. After the magnet is leveled, remove the six leveling markers.

Chapter 7 Installing a seismic vibroacoustic damping mat and leveling the magnet

Safety
<p>NOTICE</p> <p>EQUIPMENT DAMAGE RISK</p> <p>Improper damping mat installation can result in damage to the magnet.</p> <p>Tasks in this section must be done by riggers, not GE HealthCare Service Personnel. The vibroacoustic damping mats used for seismic install must be installed over the seismic studs before moving the magnet into the magnet room.</p>

7.1 Equipment overview

Tools and test equipment			
Item	Quantity	Part number	Manufacturer
PH Alignment and Magnet Leveling Kit	1	5897979	-
Tape Measure	1	-	-
Magnet Leveling Shim Kit	2	5819317	-
Vibromat Assembly, Platform	4	5802910	-
Seismic Anchor Kit, Platform (contents detailed in table below)	1	M6001AH	-
PH Alignment and Magnet Leveling Kit (5897979)			
Item	Quantity	Part number	Manufacturer
Laser Level PLS 180R Z	2	5831466	-
Tripod, Vanguard Alta Pro 263AB 100	2	5829559	-
Folding Ruler, 2 meters, FM-DELA.401.00	1	5897974	-
PM Series Magnet Template	1	5810898	-
Magnet Leveling Shim Kit (5819317)			
Item	Quantity	Part number	Manufacturer
Shim Plate, 0.5 mm Thick	8	5872197-05	-
Shim Plate, 1.5 mm Thick	8	5872197-15	-
Shim Plate, 3.0 mm Thick	4	5872197-30	-

Seismic Anchor Kit, Platform (M6001AH)			
Item	Quantity	Part number	Manufacturer
Mounting Plate	4	5817179	-
Center Ring	4	5817180	-
Collar, Seismic Kit Collector for Platform	4	5822743	-
Hex Tool, Seismic Kit Collector for Platform	1	5822744	-
Hexagon Head Screw, ISO 4017, M10-1.5 x 35 mm Long, A2-70 Stainless Steel, RoHS Fastener	16	1000-M10C035-31	-
Hexagon Socket Head Cap Screw, ISO 4762, M14-2 x 50 mm Long, A2-70 Stainless Steel, Passivate, RoHS Fastener	12	1000-M14C050-31	-
LOCTITE #242	1	46-170686P2	-

Required conditions
Magnet and dock installation and placement are critical to image quality and hardware reliability.

7.2 Putting a seismic mounted vibroacoustic damping mat into position



NOTE

The vibroacoustic damping mat must be installed on the floor before moving the magnet into the magnet room.

1. Make sure that the vibroacoustic kit contains the parts listed in the following table.

Table 7-1 Vibroacoustic damping mat kit (5802910)

Quantity	Part number	Description
4	5802910	Vibromat Assembly, Platform

Figure 7-1 Vibroacoustic damping mat (5802910), side view



1	Aluminum
2	Red pad

2. Make sure that the customer has installed seismic threaded rods in the concrete to match the magnet foot pattern. The rods must meet seismic requirements and have a maximum diameter of 1.25 inches and be between 5.5 and 6 inches in height above the finished floor.

NOTE

Installing GE HealthCare magnets in seismic regions is the responsibility of the customer, and should be done by riggers, not by GE HealthCare Service Personnel. The customer is required to make the decision as to how seismic regulations are met in the region based off the architect’s recommendations.

Figure 7-2 Seismic stud placement (patient end is at the bottom)

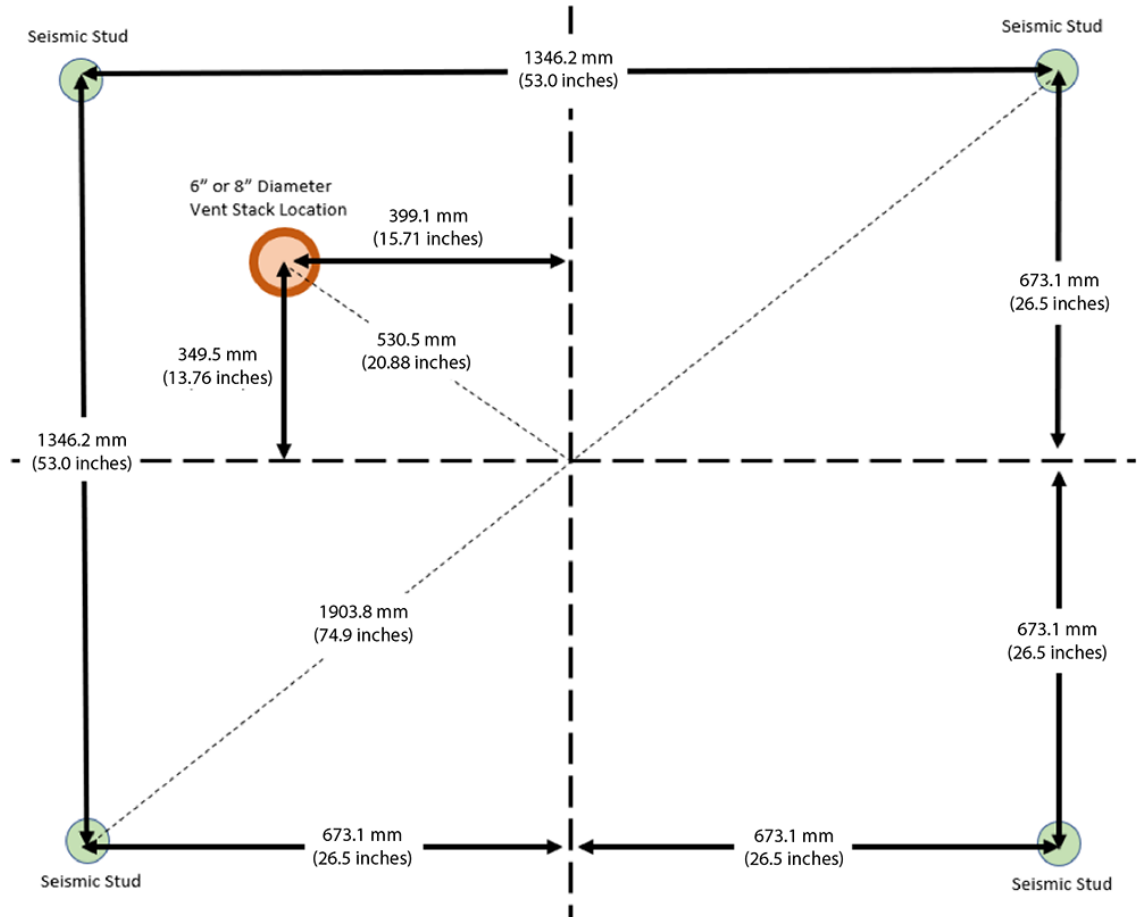

- Put the vibroacoustic damping mats on the floor, over the seismic rods, according to the prescribed markings.

Figure 7-3 Vibroacoustic mat placement (patient end is at the bottom)

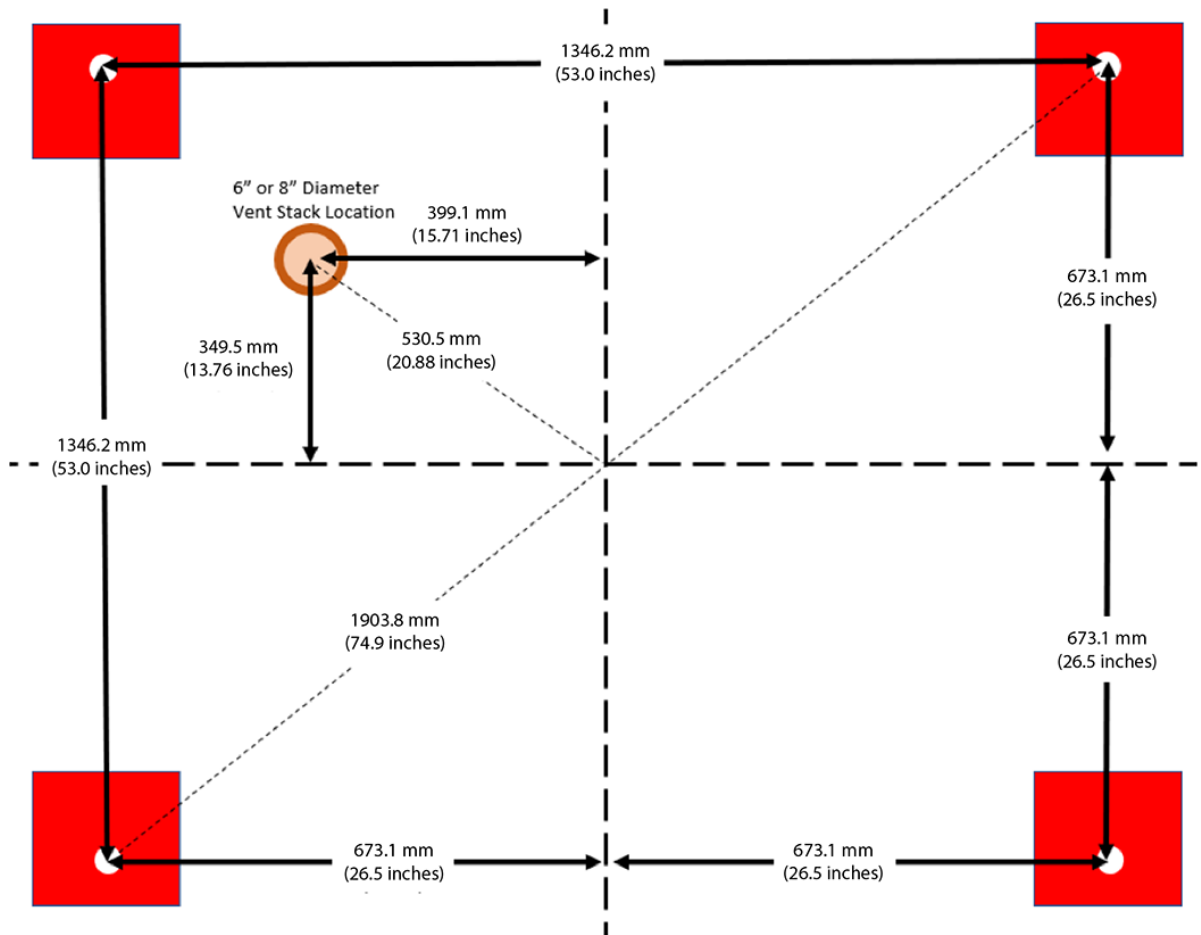
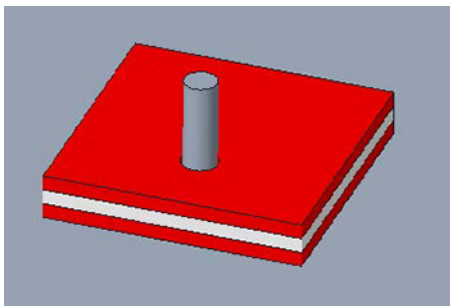



Figure 7-4 Vibroacoustic mat put over a seismic rod



7.3 Preparing to move the magnet

Safety	
	<p>DANGER</p> <p>POTENTIAL ASPHYXIATION HAZARD</p> <p>Loss of magnet vacuum will result in the rapid expulsion of helium gas, which can cause asphyxiation in enclosed areas.</p> <p>Make sure that hospital personnel are aware of this situation prior to the magnet being moved within the enclosed areas. Use extreme caution and do not contact or damage the vacuum vessel during magnet transit or siting.</p>
	<p>WARNING</p> <p>POTENTIAL INJURY HAZARD</p> <p>Moving the magnet improperly will cause personal injury or magnet damage.</p> <p>See Chapter 2 Unloading and moving the magnet on page 17 before moving the magnet using a forklift or crane.</p>
	<p>NOTICE</p> <p>EQUIPMENT DAMAGE RISK</p> <p>Improper transportation can result in damage to the magnet.</p> <p>Tasks in this section are to be done by riggers, not by GE HealthCare Personnel.</p> <p>Do not apply any force to the magnet's enclosures.</p> <p>Any floor anchors that are used to move the magnet must not penetrate the RF shield.</p> <p>Magnet and dock installation and placement are critical to image quality and hardware reliability. The magnet must be installed level with the isocenter to the specifications listed in this chapter.</p>

After the magnet is moved to the building using a crane or forklift (see [Chapter 2 Unloading and moving the magnet on page 17](#)), it needs to be moved to the magnet room. There are many methods to help move the magnet, including the use of a motorized tow vehicle, a come-along, or a chain jack. When you are moving the magnet, make sure that you are moving it in a smooth, controlled manner.

**NOTE**

Remove the lifting rails and bubble wrap at any point forward when the process allows, and you are done using the rails. When removing the bubble wrap, do not nick or cut any electrical cables.

WARNING
RISK OF DEATH, PERSONAL INJURY, OR EQUIPMENT DAMAGE

Used and/or damaged lifting rail bolts, lock washers, flat washers, and nuts can cause equipment and/or component damage, death, or serious physical injury!

Discard the used lifting rail hardware after it is removed from the magnet. This hardware must only be used one time. If lifting rails are to be reinstalled, use new, undamaged bolts, lock washers, flat washers, and nuts, which are available as FRUs that can be ordered from GE HealthCare.

1. Optionally, roller dollies are recommended for moving the magnet inside a building. If you use roller dollies, put steel floor plates along the magnet delivery route.

Figure 7-5 Magnet on roller dollies

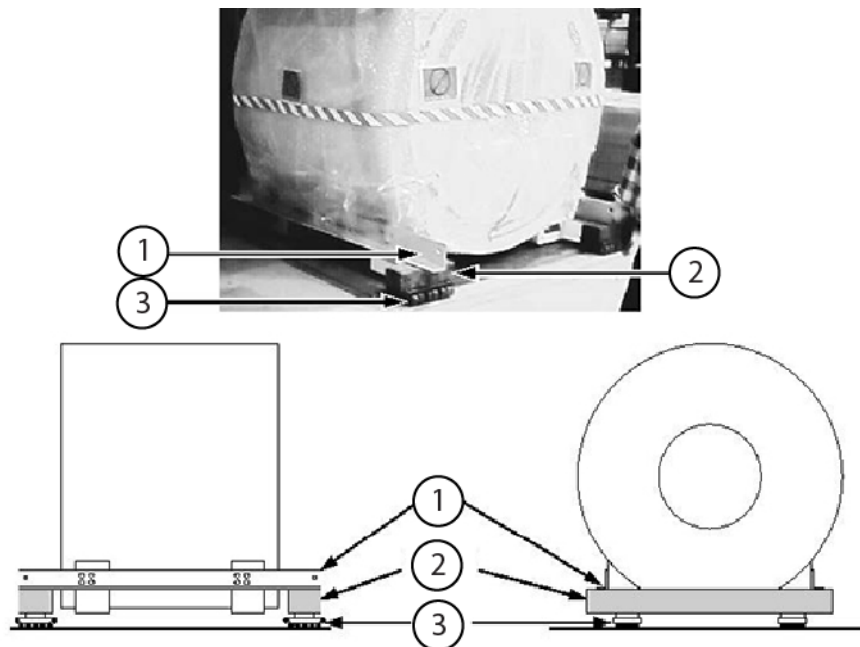

1	Lifting rails
2	100 mm x 150 mm (4 inch x 6 inch) wood beams
3	Roller dollies

2. Have the rigger make sure that walls, floors, and so on along the transportation route are protected from potential damage.
3. Attach any cables, chains, or straps used for moving the magnet to the orange lifting rails.
4. Make sure that the magnet front-rear orientation is relative to the magnet room's front and rear.

- Do a check of all clearances along the route that the magnet will move to get to the magnet room. Compare those clearances with the appropriate illustration below.

**NOTE**

Magnet image is shown for reference and may differ from the configuration shipped. The dimensions indicated are for the condition as shipped.

**NOTE**

Dimensions referenced are worst-case scenarios.

Figure 7-6 Clearance dimensions, magnet patient end as-shipped condition

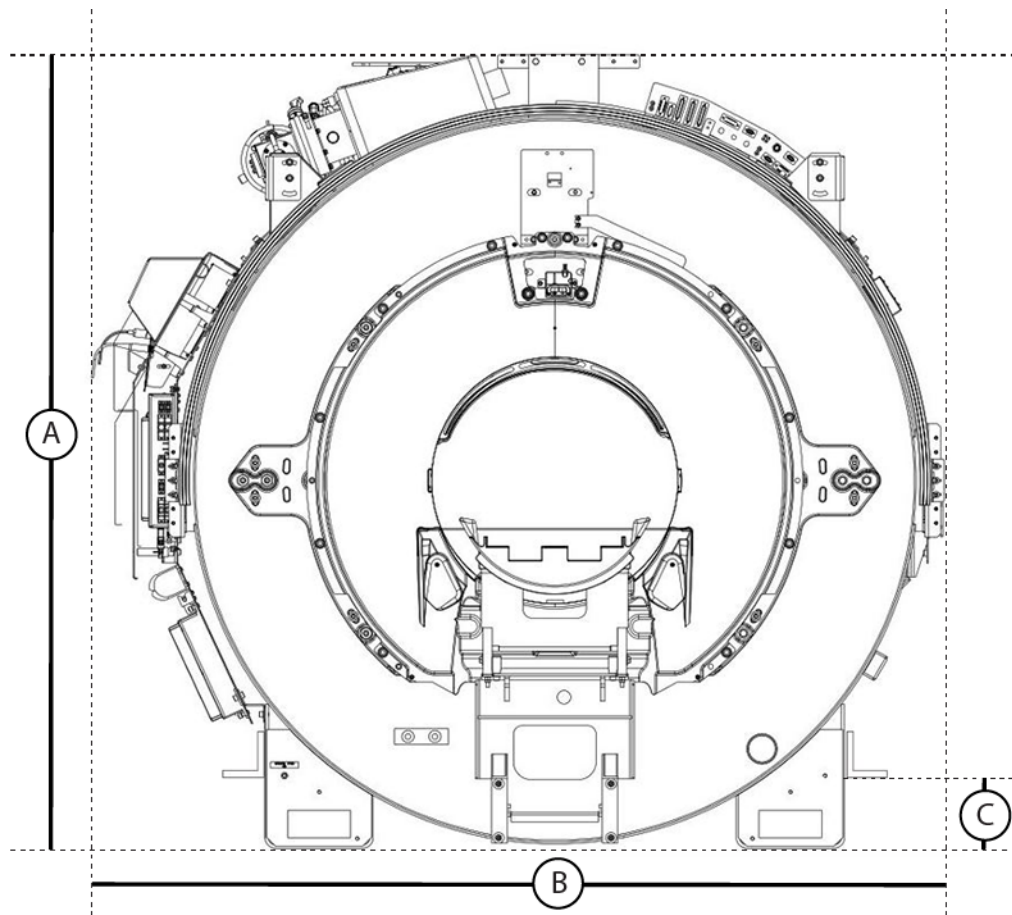

Maximum dimension	AR series magnet
A	2250 mm (88.58 inches)
B	2311 mm (90.98 inches)
C	194 mm (7.64 inches)

Figure 7-7 Clearance dimensions, magnet service side as-shipped condition

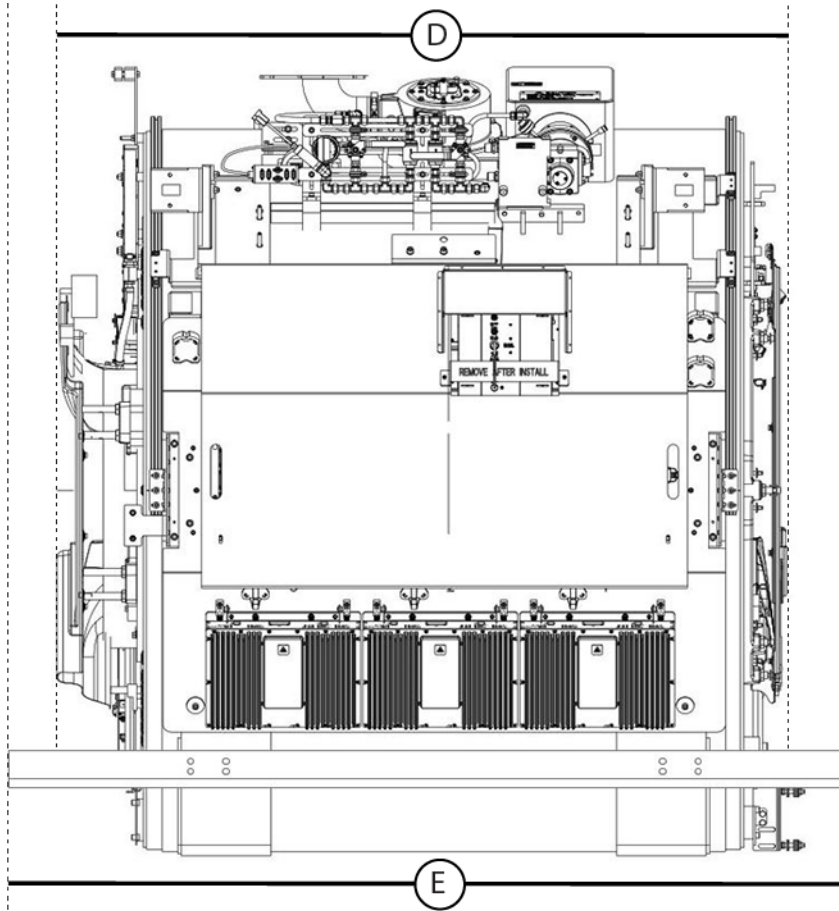

Maximum dimension	AR series magnet
D	2140 mm (84.30 inches)
E	2388 mm (94.00 inches)

The actual dimension could be less than or equal to the maximum dimension. Refer to the appropriate Preinstallation Manual (see [Appendix B Preinstallation Manual reference on page 109](#)). Only dimensions B and D are variable based on system type.

6. Compare the dimensions of the magnet on the moving fixtures being used with the clearances measured along the magnet delivery route. The height can be reduced by putting the moving fixtures directly under the lifting rails.

7.4 Moving the magnet into the MR suite

Safety	
	<p>CAUTION</p> <p>POTENTIAL PERSONAL INJURY</p> <p>Uneven jacking of the magnet's corners could result in the magnet shifting on the jacks, which may lead to personal injury or magnet damage.</p> <p>Keep the magnet level at all times during any jacking operation.</p>
	<p>NOTICE</p> <p>EQUIPMENT DAMAGE RISK</p> <p>Improper loads on enclosure cover parts can result in damage to the enclosure.</p> <p>Do not apply any loads to enclosure cover parts.</p> <p>Do not allow straps, cables, or chains to scrape enclosure cover parts.</p>

1. If raising the magnet is required, the lifting portion of the jack must be fully below the lifting rails.
2. Avoid tilting or rotating the magnet while moving it into the MR suite.
3. From the magnet room entrance to the magnet's final position, put steel floor plates as needed to protect the magnet room floor. The rigger must take actions necessary to make sure that walls, floors, and so on along the transportation route/path are protected from potential damage.
4. Move the magnet to the magnet room. (If using a motorized tow vehicle, attach cables, chains, or straps to the magnet's lifting rails with shackles.)

7.5 Lowering the magnet into position

1. Cut open and remove enough of the bubble wrap to allow access to the feet and for leveling operations.

**NOTE**

When cutting off the bubble wrap, do not nick or cut any electrical cables.

2. Move the magnet to align the holes in the magnet feet to the anchor holes in the vibroacoustic damping mats.
3. Make sure that the four holes, one per each magnet foot, align centered ± 3 mm (± 0.125 inches) over the seismic anchor holes in the vibroacoustic mats.
4. Jack the magnet up sufficiently at the two lifting rails (four corners), and remove the moving fixtures.
5. Slowly lower the magnet onto the vibroacoustic mats. Make sure the threaded seismic rods go through the holes in the magnet feet.

Figure 7-8 Magnet foot put on a vibroacoustic mat over a seismic rod

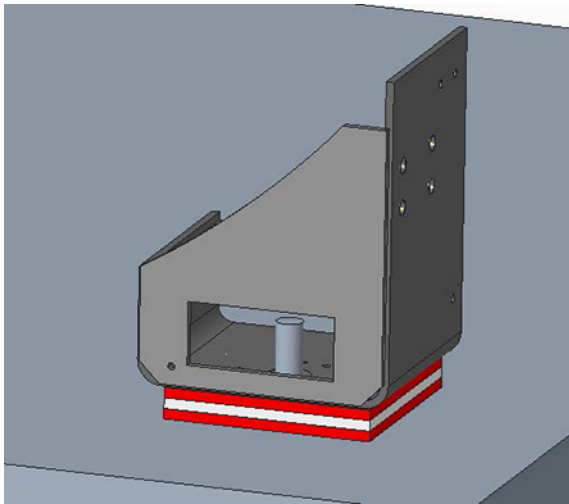

Figure 7-9 Lowering the magnet onto the vibroacoustic damping mats

6. Release pressure simultaneously in both jacks on one end of the magnet until that end is 25 to 50 mm (1 to 2 inches) lower than the opposite end.
7. Simultaneously lower both jacks on the other end 25 to 50 mm (1 to 2 inches).
8. Repeat lowering the magnet end to end until all feet are on the vibroacoustic mats, correctly located on the magnet feet bolt holes.

7.6 Adding leveling shims

Review this section before you begin to level the magnet. If, while leveling the magnet, you need to insert shims under a magnet foot to achieve correct leveling, this section provides instructions for raising any one of the four magnet feet and properly placing shims with respect to the specific vibroacoustic mat.

1. Use a jack to raise the lowest magnet foot.
2. Insert the appropriate thickness of aluminum shim plates under the low magnet foot.
3. Put the shims on the floor, under the vibroacoustic mat, making sure the surface is solid and can support the magnet weight.

Figure 7-10 Shim arrangement

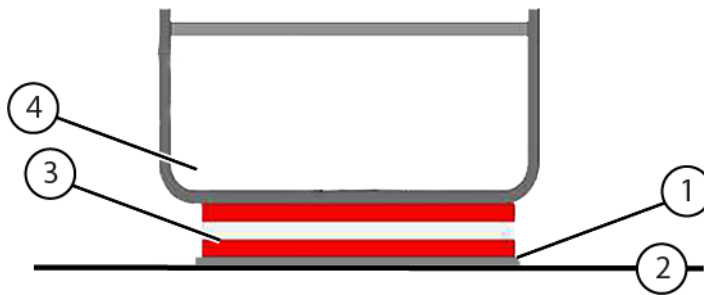

1	Leveling shims
2	Floor surface
3	Vibroacoustic mat
4	Magnet foot

7.7 Leveling an AR series magnet

1. Make sure the laser level is in self-leveling mode.



NOTE

In self-leveling mode, if the laser level tilts $> 4^\circ$ in any direction, the lasers do not show. When the laser level tilt is $\leq 4^\circ$, the level indicator LED is green and the lasers show.

Figure 7-11 Laser level in self-leveling mode (unlocked position)

- Set the laser level height to the center of the highest of the four side targets (3 o'clock and 9 o'clock leveling markers).

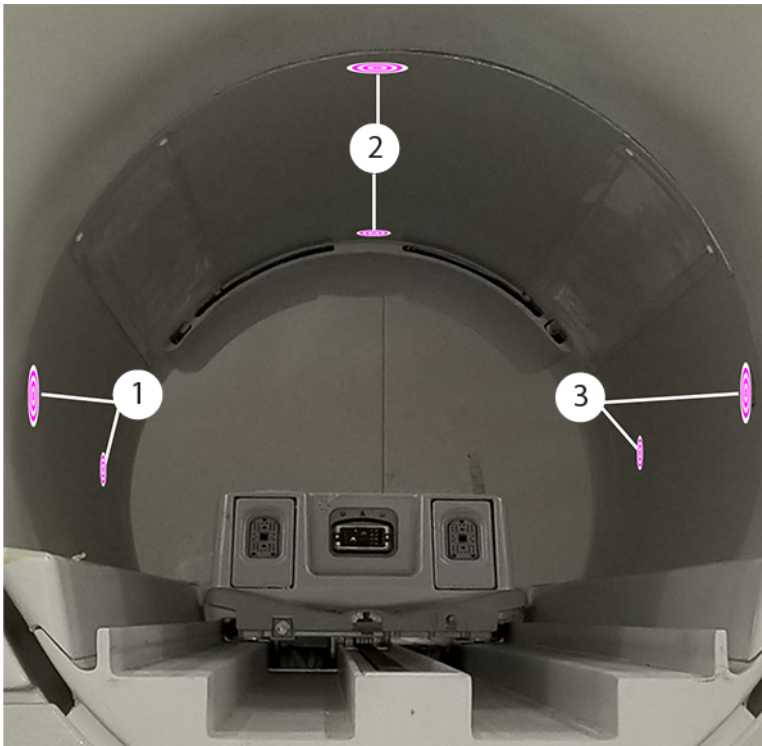
Figure 7-12 Leveling marker positions

1	9 o'clock
2	12 o'clock
3	3 o'clock

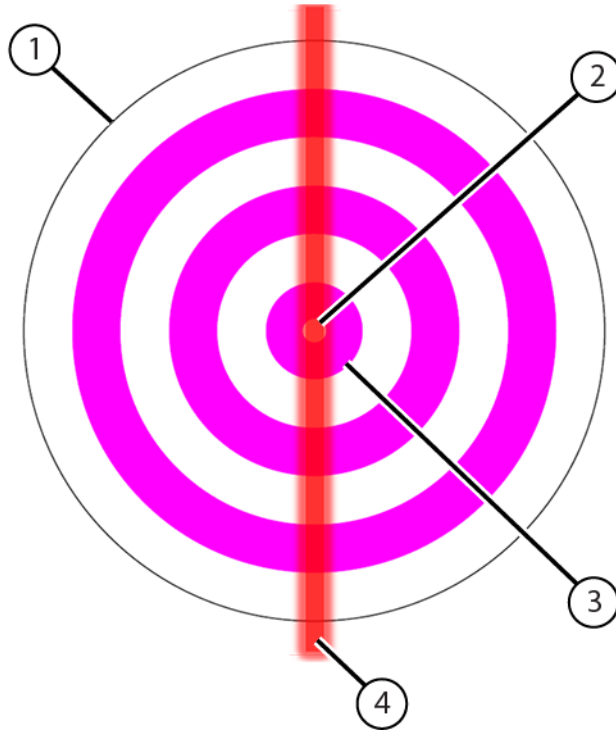
Figure 7-13 Parts of a leveling target

1	Leveling marker
2	Primary target circle, Ø 1.5 mm (0.06 inches)
3	Secondary target circle, Ø 6.4 mm (0.25 inches)
4	Projected laser line

**NOTE**

This figure is not to scale.

- Complete the following substeps to check front-to-back (superior to inferior) levelness:

**NOTE**

Measure front-to-back leveling relative to the 3 o'clock and 9 o'clock leveling markers at both ends of the body coil.

- Make sure the projected laser line completely covers the primary target circle on the leveling target.
- Add leveling shims under the vibroacoustic damping mat at each magnet foot, per the [7.6 Adding leveling shims on page 92](#) procedure, to achieve the correct front-to-back levelness based on the laser line positions and shim requirements shown below.

**NOTE**

If you need to open a second box of shims, check the floor levelness or contact Florence.

Figure 7-14 Laser line positions on a leveling target

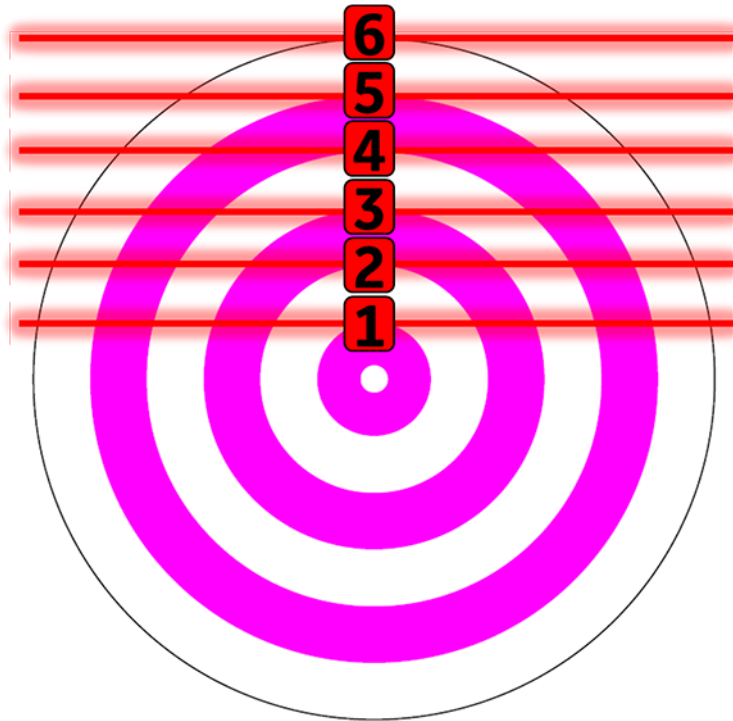

Table 7-2 Laser line shim requirements (front-to-back)

Laser line position	How far magnet foot needs to be raised (mm)	Number of 3 mm shims	Number of 1.5 mm shims	Number of 0.5 mm shims
1	3.5	1	0	1
2	6.9	2	0	2
3	10.4	3	1	0
4	13.9	4	1	1
5	17.3	5	1	2
6	20.8	Check floor levelness		

4. Complete the following substeps to check left-to-right levelness:

NOTE

Measure left-to-right leveling relative to the 3 o'clock and 9 o'clock leveling markers at both ends of the body coil.

- 4.1. Make sure the projected laser line completely covers the primary target circle on the leveling target.
- 4.2. Add leveling shims under the vibroacoustic damping mat at each magnet foot, per the [7.6 Adding leveling shims on page 92](#) procedure, to achieve the correct left-to-right levelness based on the laser line positions and shim requirements shown below.

NOTE

If you need to open a second box of shims, check the floor levelness or contact Florence.

Table 7-3 Laser line shim requirements (left-to-right)

Laser line position	How far magnet foot needs to be raised (mm)	Number of 3 mm shims	Number of 1.5 mm shims	Number of 0.5 mm shims
1	4.2	1	0	2
2	8.4	2	1	2
3	12.6	4	0	1
4	16.7	5	1	0
5	20.9	Check floor levelness		

5. Complete the following substeps to check magnet height:

**NOTE**

Measure height leveling relative to the 3 o'clock and 9 o'clock leveling markers at both ends of the body coil.

- 5.1. Make sure the projected laser line completely covers the primary target circle on the leveling target.
- 5.2. Make sure the horizontal laser line from the front laser level still aligns 1070 mm (42.13 inches) from the floor at the front of the magnet. Accuracy is critical here.
- 5.3. If necessary, put a folding ruler in position vertically near the front center of the magnet, and adjust the tripod height until the horizontal laser line aligns on the ruler 1070 mm (42.13 inches) from the floor (the magnet isocenter should be 1064 to 1076 mm). Compare the laser position to the targets inside the body coil.
- 5.4. Add leveling shims under the vibroacoustic damping mat at each magnet foot, per the [7.6 Adding leveling shims on page 92](#) procedure, to achieve the correct height based on the laser line positions and shim requirements shown below.

**NOTE**

If you need to open a second box of shims, check the floor levelness or contact Florence.

Table 7-4 Laser line shim requirements (height)

Laser line position	How far magnet foot needs to be raised (mm)	Number of 3 mm shims	Number of 1.5 mm shims	Number of 0.5 mm shims
1	3.2	1	0	0
2	6.4	2	0	1
3	9.6	3	0	1
4	12.8	4	0	2
5	16.0	5	0	2

6. Some of the leveling markers may no longer fit in the primary target circle on the leveling target. **For acceptability, at least three of the four side leveling markers must be completely covered by the primary target circle. The remaining marker must have complete coverage in the secondary target circle. (For seismic installations, the markers in the 12 o'clock position are not used.)**

7. Test-fit the cryogen vent stack to make sure it aligns with the scan room vent pipe.
8. After the magnet is leveled, remove the six leveling markers.

7.8 Seismic mounting of a vibroacoustic damping mat to the floor

Installing GE HealthCare magnets in seismic regions is the customer's responsibility. This section provides the process of how to install magnets in seismic regions using GE HealthCare vibroacoustic mats. However, this is only one way to achieve seismic installation. The customer is required to make the decision as to how seismic regulations are met in the region based off the architect's recommendations.



NOTE

Tasks in this section are to be done by riggers, not by GE HealthCare Service Personnel. The vibroacoustic mats used for seismic install must be installed over the seismic studs before moving the magnet into the magnet room.



NOTE

The seismic kit does not include studs, washers, and nuts. It is the customer's responsibility to buy the correct studs, washers, and nuts for their region based off the architect's recommendation.

The following mounting depiction is one of many ways to install magnets seismically and by no means is the mandatory method. Follow these steps for each magnet foot.

1. Install the rubber collar (5822743) from the Seismic Anchor Kit, Platform (M6001AH) on the inner diameter of the magnet foot.

Figure 7-15 Rubber collar on the magnet foot

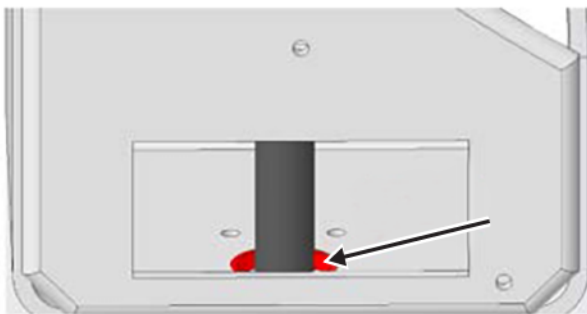

- Put the stainless steel center ring (5817180) from the kit on the threaded seismic rod.

Figure 7-16 Center ring on a threaded seismic rod

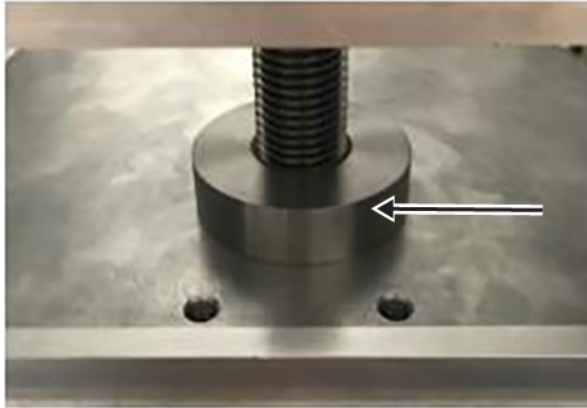

- Screw three of the M14 screws (1000-M14C050-31) from the kit into the stainless steel mounting plate (5817179) until the screws reach the inner diameter of the plate, as shown below.

Figure 7-17 M14 screws installed in the mounting plate

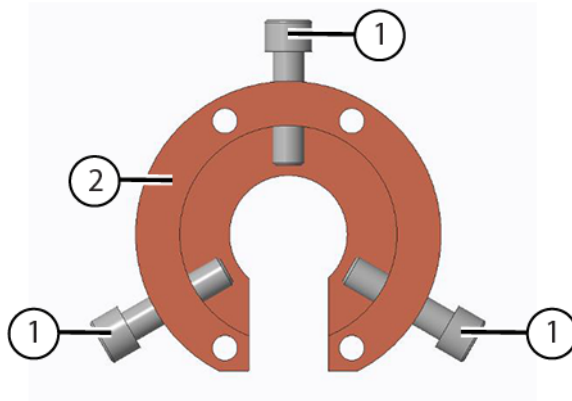

1	M14 screws
2	Mounting plate

- Put the mounting plate through the opening in the magnet foot, around the seismic rod and over the center ring, with the flush side of the plate pointed toward the ceiling. Make sure the flat edge of the mounting plate points toward the opening in the magnet foot.

Figure 7-18 Mounting plate around the seismic rod, over the center ring

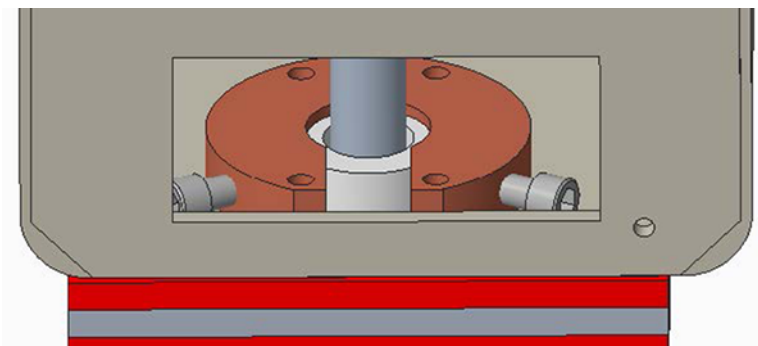

5. Screw four of the M10 screws (1000-M10C035-31) from the kit through the mounting bracket and engage the threads into the magnet foot. Using a ratchet or wrench, firmly tighten the M10 screws.

Figure 7-19 M10 screws

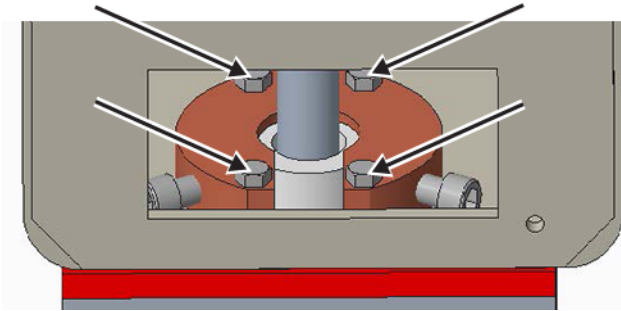

6. Hand-tighten the three M14 screws up to the center ring. If needed, use the hex tool (5822744) from the kit to help in tightening.

Figure 7-20 Using the hex tool to tighten M14 screws

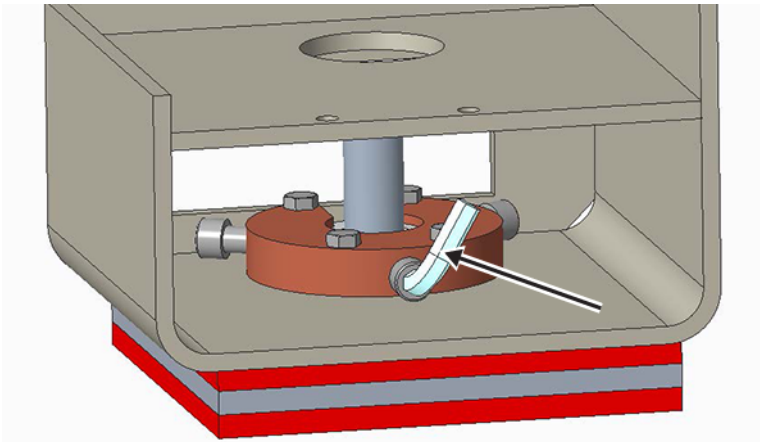

7. Put an appropriately sized flange nut on the seismic stud. Hand-tighten the flange nut toward the mounting plate; then back off one full turn to make sure there is a gap between the flange nut and the mounting plate.

Figure 7-21 Gap between flange nut and mounting plate

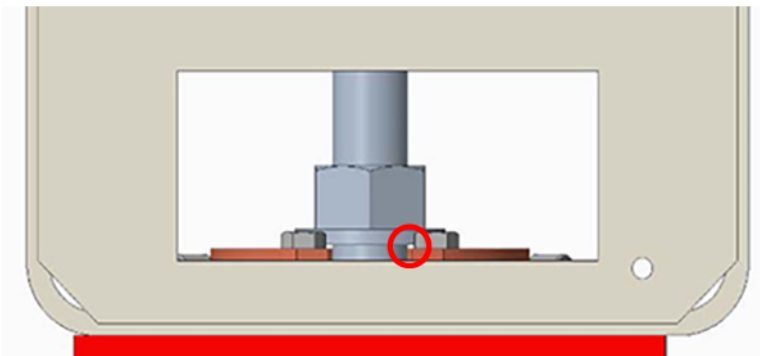

- Put a Nord-Lock washer on top of the flange nut.

Figure 7-22 Nord-Lock washer on flange nut

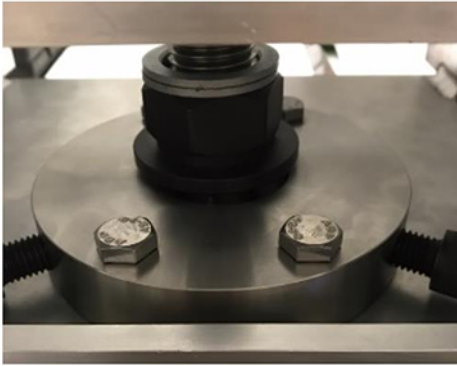

- Put a jam nut on top of the Nord-Lock washer and hand-tighten.

Figure 7-23 Jam nut on Nord-Lock washer

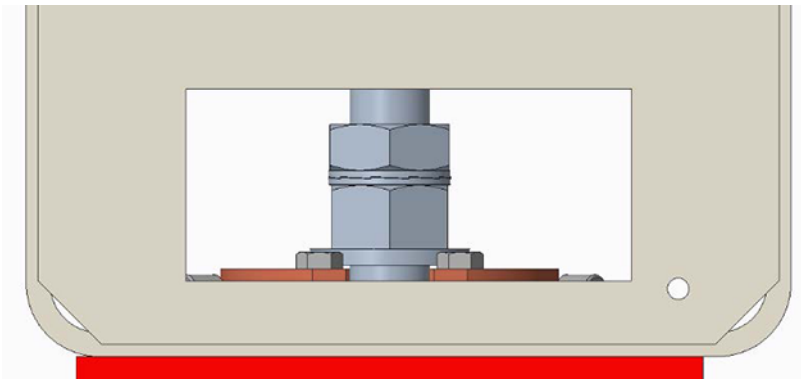

- Using two wrenches, tighten the jam nut while keeping the flange nut in position. Make sure there is still a gap between the flange nut and the mounting plate.

Chapter 8 Centering the table dock bolt for an AR series magnet

1. Put the appropriate *Dock Station (Detachable) and Fixed Table Positioning Template* on the floor in front of the magnet, following the instructions on the template (for example, for 5822261, put the template below the cable retention bracket).



NOTE

The *Dock Station (Detachable) and Fixed Table Positioning Template* ships with the magnet.

Table 8-1 Dock bolt positioning templates

Product system	Template
SIGNA Premier	5822261
SIGNA Hero	
SIGNA Pioneer	
SIGNA PET/MR	5822261-5
SIGNA Architect	5822261-7

Figure 8-1 Dock bolt positioning template (SIGNA Premier, SIGNA Hero, and SIGNA Pioneer: 5822261)

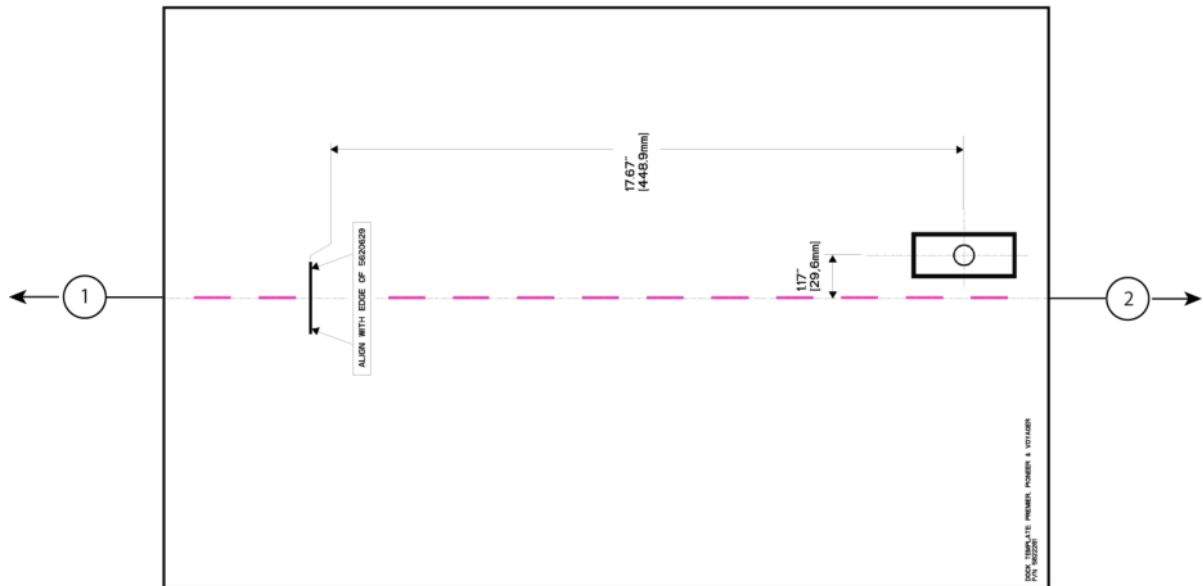

1	Toward the magnet
2	Away from the magnet

Figure 8-2 Dock bolt positioning template (SIGNA PET/MR: 5822261-5)

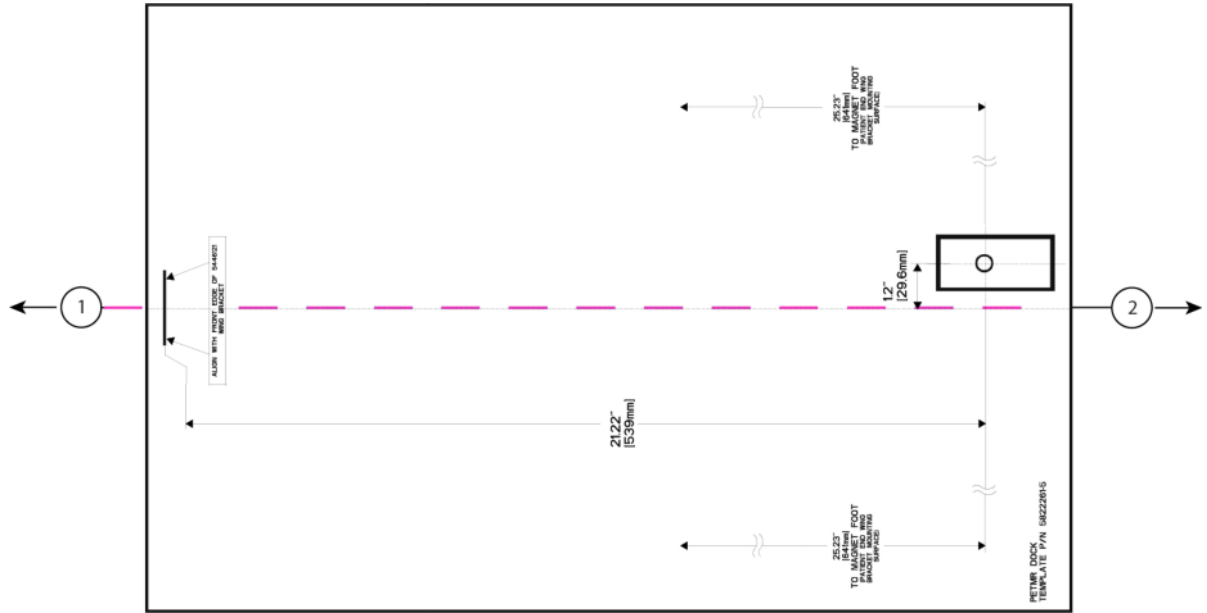

1	Toward the magnet
2	Away from the magnet

Figure 8-3 Dock bolt positioning template (SIGNA Architect: 5822261-7)

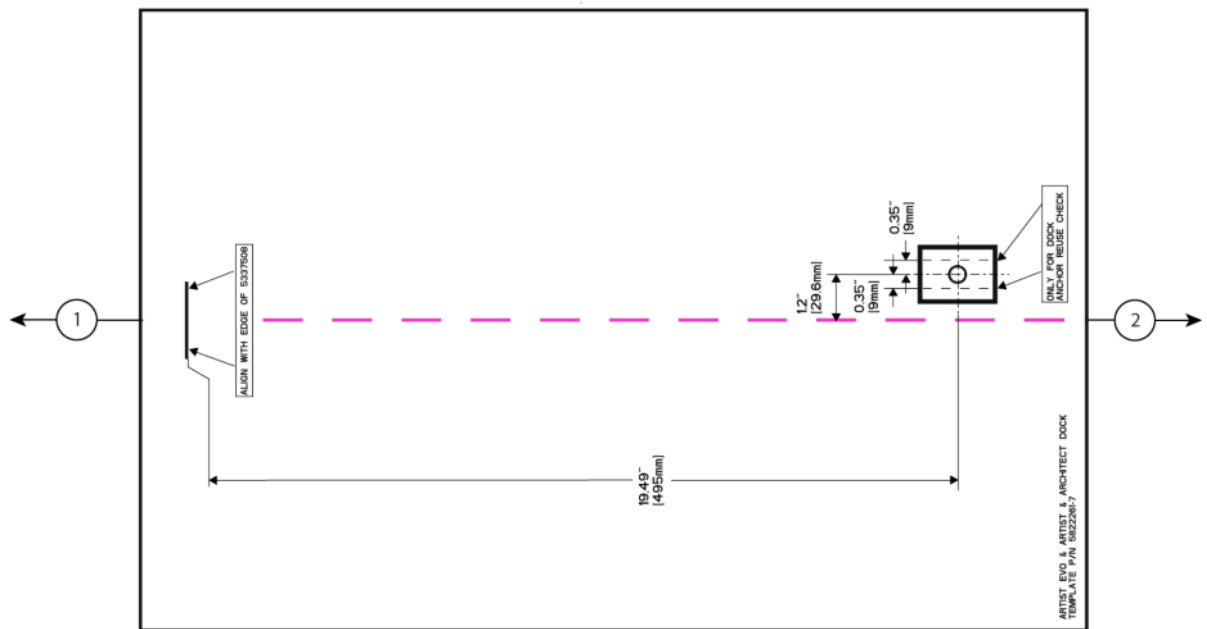

1	Toward the magnet
2	Away from the magnet

- Align the lateral (x-dir) line of the positioning template as indicated on the template.

Table 8-2 Dock bolt positioning template alignment

Template	Alignment instruction
5822261	Use a straight edge to align with the leading edge of the cable retention bracket.
5822261-5	<ul style="list-style-type: none"> If the bridge support is available, align the template directly with the edge of the bridge support wing bracket. If the bridge support is not available, make marks on the floor using a folding ruler and the measurement provided on the template from the magnet feet. Then use the second laser in the kit to align the template with these marks.
5822261-7	Use the second laser in the kit to align with the front edge of the plate base tie.

Figure 8-4 Aligning positioning template 5822261 with the cable retention bracket

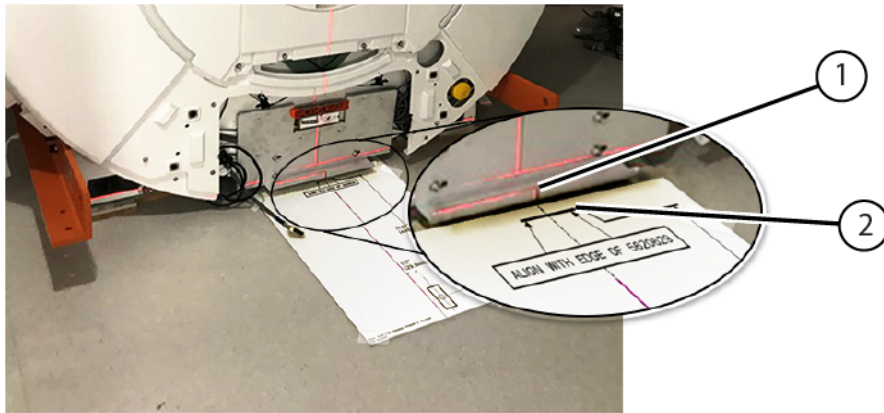

1	Cable retention bracket leading edge
2	Lateral (x-dir) line of positioning template

Figure 8-5 Aligning positioning template 5822261-5 with the edge of the bridge support wing bracket (left) or floor markings (right)

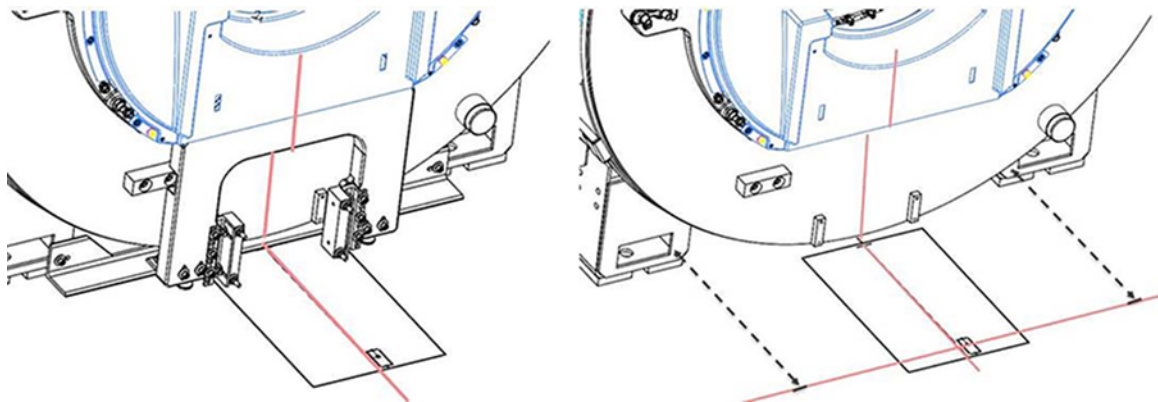
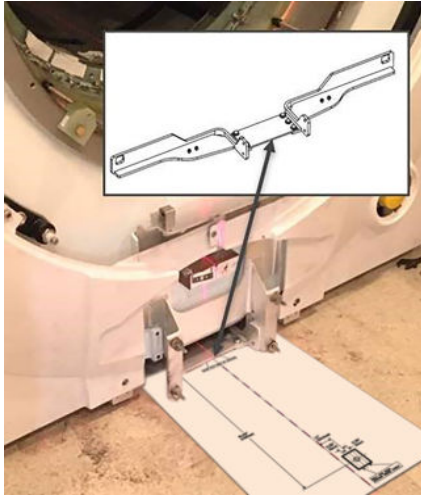

Figure 8-6 Aligning positioning template 5822261-7 with the front edge of the plate base tie

3. Adjust the laser level until the vertical laser line passes through the primary target circle on the 12 o'clock leveling markers at both ends of the body coil.

**NOTE**

For SIGNA Premier, SIGNA Hero, and SIGNA Pioneer, do not assume the vertical line marked on the cable retention bracket is centered.

4. Use the laser line to align the longitudinal (z-dir) center line of the positioning template (dashed fuchsia line) with the magnet geometric isocenter (primary targets on the leveling markers).

**NOTE**

The front edge aligned in [Step 2](#) should be on the same plane as the line on the template.

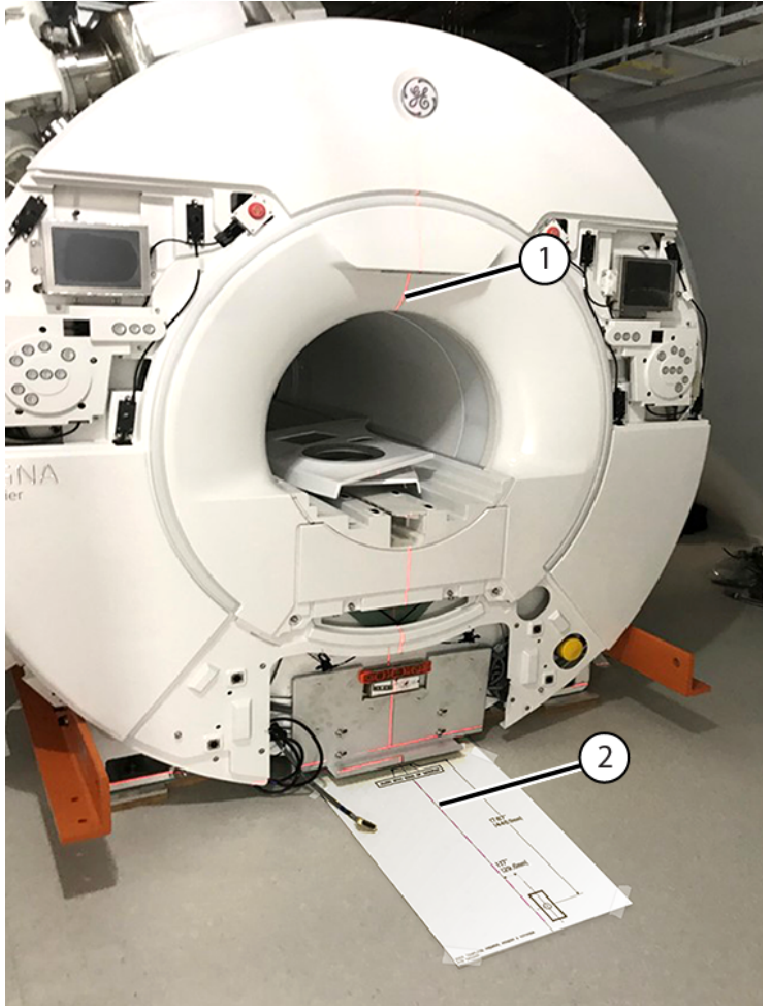
Figure 8-7 Aligning positioning template 5822261 with the primary targets on leveling markers

1	Laser line aligned with 12 o'clock leveling markers
2	Positioning template longitudinal (z-dir) axis

**NOTE**

While this figure shows template 5822261, its placement in the figure is representative of the placement of any AR series template.

5. Use tape to secure the positioning template to the floor.
6. Drill the dock anchoring hole using the prescribed marking on the positioning template for guidance.

**NOTE**

For details about dock anchor construction requirements, refer to the *RF Shielded Room Preinstallation Requirements for MR Systems (5850260-1EN)*.

Page intentionally left blank

Appendix A Volumetric conversion of Magnet Monitor cryogen percentage to liquid helium level

Table A-1 Volumetric conversion of liquid helium level (meter reading to liquid liters correlation)

Level (%)	Liquid helium (liters)	Level (%)	Liquid helium (liters)	Level (%)	Liquid helium (liters)	Level (%)	Liquid helium (liters)	Level (%)	Liquid helium (liters)	Level (%)	Liquid helium (liters)
0	0	17	418	34	764	51	1050	68	1330	85	1619
1	137	18	439	35	781	52	1067	69	1347	86	1637
2	151	19	461	36	797	53	1083	70	1363	87	1655
3	166	20	482	37	814	54	1100	71	1380	88	1672
4	180	21	503	38	831	55	1116	72	1396	89	1690
5	195	22	525	39	848	56	1132	73	1413	90	1708
6	209	23	546	40	865	57	1149	74	1430	91	1729
7	224	24	568	41	882	58	1165	75	1447	92	1750
8	238	25	589	42	899	59	1182	76	1463	93	1771
9	253	26	610	43	916	60	1198	77	1480	94	1792
10	267	27	632	44	933	61	1215	78	1497	95	1814
11	289	28	653	45	950	62	1231	79	1513	96	1835
12	310	29	675	46	966	63	1248	80	1530	97	1856
13	332	30	696	47	983	64	1264	81	1548	98	1877
14	353	31	713	48	1000	65	1281	82	1566	99*	1898
15	375	32	730	49	1017	66	1297	83	1583	100*	1919
16	396	33	747	50	1034	67	1314	84	1601		

*Magnet Monitor or the level sensor cannot get a reading above 100% or 1919L; **do not fill the magnet above 98% or 1877L for any reason.**

Page intentionally left blank

Appendix B *Preinstallation Manual* reference



NOTE

The table below contains a selection of manuals for product systems with an AR series magnet. It is not an exhaustive list.

Description	Direction or part number
SIGNA™ PET/MR Preinstallation Manual	5480759
SIGNA™ Architect (Platform Cooling Cabinet Configuration with ICC/pICC) Preinstallation Manual	5670003
SIGNA™ Architect, Discovery MR750w (Legacy Cooling Cabinet Configuration with HEC) Preinstallation Manual	5671000-8EN
SIGNA™ Pioneer 3.0T Preinstallation Manual	5680003-1EN
SIGNA™ Premier Preinstallation Manual	5815067
SIGNA™ Hero / SIGNA™ Performer / SIGNA™ Pilot Preinstallation Manual	5852803-1EN

Page intentionally left blank

Revision history

Revision	Date	Description
		Controlled document for English is posted as DOC2587155.

Revision	Date	Description
7	August 2025	<ul style="list-style-type: none"> • In Chapter 1 Getting started: <ul style="list-style-type: none"> ◦ Section 1.4 <i>Predelivery instructions</i>, step 1: added new sub-step 1.8 to review the <i>Rigging</i> section. ◦ Added new section 1.5 <i>Rigging</i>. • In Chapter 3 Magnet storage conditions, pending ramp, section 3.3 <i>Monitoring the magnet</i>, substep 3.2, Note: <ul style="list-style-type: none"> ◦ Added the words "in order" to "Magnet Monitor 4 (MM4) can also be set to Storage mode by doing the following in order". ◦ Changed the substeps in the Note to a bulleted list. • In Chapter 5 Preparing the scan room, section 5.1 <i>Preparing the scan room for leveling an AR series magnet</i>, steps 9 and 13: changed "site" to "sight". • In Chapter 6 Installing a nonseismic vibroacoustic damping mat and leveling the magnet: <ul style="list-style-type: none"> ◦ Section 6.1 <i>Equipment overview, Tools and test equipment table</i>, item <i>Magnet Leveling Shim Kit</i> (5819317): changed quantity from 1 to 2. ◦ Section 6.3 <i>Preparing to move the magnet</i>, step 5: <ul style="list-style-type: none"> • Added the Note "Dimensions referenced are worst-case scenarios". • <i>Figure 6-4 Clearance dimensions, magnet patient end as-shipped condition</i>: <ul style="list-style-type: none"> • Renamed the first column to "Maximum dimension". • Deleted the "SIGNA PET/MR" "SIGNA Architect", and "SIGNA Pioneer" columns. • Renamed the "SIGNA Premier, SIGNA Hero" column to "AR series magnet". • Updated the B entry dimension to "2311 mm (90.98 inches)" (previously this was the SIGNA Architect dimension). • <i>Figure 6-5 Clearance dimensions, magnet service side as-shipped condition</i>: <ul style="list-style-type: none"> • Renamed the first column to "Maximum dimension". • Deleted the "SIGNA PET/MR", "SIGNA Architect", and "SIGNA Pioneer" columns. • Renamed the "SIGNA Premier, SIGNA Hero" column to "AR series magnet". • Added the following statement: "The actual dimension could be less than or equal to the maximum dimension. Refer to the appropriate Preinstallation Manual (see <i>Preinstallation Manual reference</i>). Only dimensions B and D are variable based on system type." • In Chapter 7 Installing a seismic vibroacoustic damping mat and leveling the magnet: <ul style="list-style-type: none"> ◦ Section 7.1 <i>Equipment overview, Tools and test equipment table</i>, item <i>Magnet Leveling Shim Kit</i> (5819317): changed quantity from 1 to 2. ◦ Section 7.3 <i>Preparing to move the magnet</i>, step 5: <ul style="list-style-type: none"> • Added the Note "Dimensions referenced are worst-case scenarios".

Revision	Date	Description
		<ul style="list-style-type: none"> • <i>Figure 7-6 Clearance dimensions, magnet patient end as-shipped condition:</i> <ul style="list-style-type: none"> • Renamed the first column to "Maximum dimension". • Deleted the "SIGNA PET/MR" "SIGNA Architect", and "SIGNA Pioneer" columns. • Renamed the "SIGNA Premier, SIGNA Hero" column to "AR series magnet". • Updated the B entry dimension to "2311 mm (90.98 inches)" (previously this was the SIGNA Architect dimension). • <i>Figure 7-7 Clearance dimensions, magnet service side as-shipped condition:</i> <ul style="list-style-type: none"> • Renamed the first column to "Maximum dimension". • Deleted the "SIGNA PET/MR", "SIGNA Architect", and "SIGNA Pioneer" columns. • Renamed the "SIGNA Premier, SIGNA Hero" column to "AR series magnet". • Added the following statement: "The actual dimension could be less than or equal to the maximum dimension. Refer to the appropriate Preinstallation Manual (see <i>Preinstallation Manual reference</i>). Only dimensions B and D are variable based on system type." • In Appendix A Volumetric conversion of Magnet Monitor cryogen percentage to liquid helium level, <i>Table A-1 Volumetric conversion of liquid helium level (meter reading to liquid liters correlation)</i>: added asterisk (*) to "99" to correlate to the sentence at the bottom of the table "Magnet Monitor or the level sensor cannot get a reading above 100% or 1919L; do not fill the magnet above 98% or 1877L for any reason." • Appendix B Preinstallation Manual reference: <ul style="list-style-type: none"> ◦ Added the word "System" to <i>SIGNA™ PET/MR System Preinstallation Manual</i> and <i>SIGNA™ Pioneer 3.0T System Preinstallation Manual</i>. ◦ Changed <i>SIGNA™ Hero Preinstallation Manual</i> to <i>SIGNA™ Hero / SIGNA™ Performer / SIGNA™ Pilot Preinstallation Manual</i>.

Revision	Date	Description
6	June 2024	<ul style="list-style-type: none"> • Added a Language Policy. • Updated all GE references to GE HealthCare. • Changed all instances of the verb form <i>position</i> to <i>put</i>. • In section 2.6, Removing the shipping cage, added step 4. • In section 2.7, Removing the shipping crate, added step 16. • In section 2.9, Unloading the uncrated magnet with a crane to ground, added a Note in step 2 to make sure the cable bridles/slings do not touch the magnet covers. • In section 2.10, Lifting the magnet with a crane through the opening in the exterior wall, added a Note in step 2 to make sure the cable bridles/slings do not touch the magnet covers. • Section 3.1, Connecting the magnet to the compressor: <ul style="list-style-type: none"> ◦ Updated Figure 3-2 Using two wrenches to tighten a connection. ◦ Added a Note to step 5 to not put any bending force on Aeroquip fittings while connecting/disconnecting helium flexlines. • In section 3.2, Connecting the magnet monitoring connections, updated the title of Figure 3-6 from <i>Typical instrumentation box ports</i> to <i>Typical instrumentation connector assembly ports</i>. • In section 4.2, Doing a magnet system check, removed the Note (<i>Because of the higher boil-off and helium gas flow through the vertical penetration on all shipments, some frost on the vertical penetration may be normal during periods when the coldhead has been shut off.</i>) from step 4. • In section 5.1, Preparing the scan room for leveling, added SIGNA PET/MR to the titles of the figures below: <ul style="list-style-type: none"> ◦ Figure 5-2 Isocenter location and z-axis vector, SIGNA Architect and SIGNA PET/MR ◦ Figure 5-5 Isocenter location and vent pipe location, SIGNA Architect and SIGNA PET/MR • In sections 6.3 and 7.3, Preparing to move the magnet: <ul style="list-style-type: none"> ◦ Added a Warning about lifting rail hardware to the Note about removing the lifting rails and bubble wrap. ◦ In step 5, updated the clearance dimension value C for the figures below: <ul style="list-style-type: none"> • Figure 6-4 Clearance dimensions, magnet patient end as-shipped condition • Figure 7-6 Clearance dimensions, magnet patient end as-shipped condition ◦ In step 5, added SIGNA PET/MR clearance dimension values for the figures below: <ul style="list-style-type: none"> • Figure 6-4 Clearance dimensions, magnet patient end as-shipped condition • Figure 6-5 Clearance dimensions, magnet service side as-shipped condition • Figure 7-6 Clearance dimensions, magnet patient end as-shipped condition • Figure 7-7 Clearance dimensions, magnet service side as-shipped condition

Revision	Date	Description
		<ul style="list-style-type: none"> ◦ In step 5, consolidated the SIGNA Hero and SIGNA Premier clearance dimension columns, since the values are the same. • Sections 6.8 and 7.7, Leveling an AR series magnet: <ul style="list-style-type: none"> ◦ Added a Note after steps 3.2, 4.2, and 5.4. ◦ In step 5.3, changed $1070 \pm 6 \text{ mm}$ to 1064 to 1076 mm. ◦ Added step 8. • In Chapter 8, Centering the table dock bolt for an AR series magnet: <ul style="list-style-type: none"> ◦ Added a Note to step 1. ◦ Added SIGNA PET/MR to <i>Table 8-1 Dock bolt positioning templates</i>. ◦ Added <i>Figure 8-2 Dock bolt positioning template (SIGNA PET/MR: 5822261-5)</i>. ◦ Added 5822261-5 to <i>Table 8-2 Dock bolt positioning template alignment</i>. ◦ Added <i>Figure 8-5 Aligning positioning template 5822261-5 with the edge of the bridge support wing bracket (left) or floor markings (right)</i>. • In Appendix B, <i>Preinstallation Manual</i> reference: <ul style="list-style-type: none"> ◦ Updated the title for 5670003. ◦ Added 5671000-8EN and 5480759.

Revision	Date	Description
5	July 2023	<ul style="list-style-type: none"> • In section 5.1, Preparing the scan room for leveling an AR series magnet, the figures below were added: <ul style="list-style-type: none"> ◦ Figure 5-2 Isocenter location and z-axis vector, SIGNA Architect ◦ Figure 5-3 Isocenter location and z-axis vector, SIGNA Pioneer ◦ Figure 5-5 Isocenter location and vent pipe location, SIGNA Architect ◦ Figure 5-6 Isocenter location and vent pipe location, SIGNA Pioneer • In sections 6.3 and 7.3, Preparing to move the magnet, added SIGNA Architect and SIGNA Pioneer clearance dimension values for the figures below: <ul style="list-style-type: none"> ◦ Figure 6-4 Clearance dimensions, magnet patient end as-shipped condition ◦ Figure 6-5 Clearance dimensions, magnet service side as-shipped condition ◦ Figure 7-6 Clearance dimensions, magnet patient end as-shipped condition ◦ Figure 7-7 Clearance dimensions, magnet service side as-shipped condition • In Chapter 8, Centering the table dock bolt for an AR series magnet, step 1, "Detachable" was added to the template name to clarify the term "Dock Station". • Updated Chapter 8, Centering the table dock bolt for an AR series magnet to include SIGNA Pioneer and SIGNA Architect systems: <ul style="list-style-type: none"> ◦ Updated the text in step 1 to be less specific to template 5822261, and added Table 8-1 Dock bolt positioning templates. ◦ Updated the title for Figure 8-1 to include Pioneer. Added Figure 8-2 Dock bolt positioning template (SIGNA Architect: 5822261-7). ◦ Updated the text in step 2 to be less specific to template 5822261, added Table 8-2 Dock bolt positioning template alignment, and added Figure 8-4 Aligning positioning template 5822261-7 with the front edge of the plate base tie. ◦ Updated the Note in step 3 to clarify to which systems it applies. ◦ Updated the Note in step 4 to be less specific to template 5822261. ◦ Added a Note to Figure 8-5 Aligning positioning template 5822261 with the primary targets on leveling markers. • In Appendix B, Preinstallation Manual reference, added 5670003 and 5680003-1EN.

Revision	Date	Description
4	February 2023	<ul style="list-style-type: none"> • The Revision History was moved to the end of the manual. • In section 1.3, Truck loading specifications, Table 1-2 Magnet loading specifications, changed the maximum shock load label from "Gs" to "g". • The following changes were made to Chapter 2, Unloading and moving the magnet, to reflect CAPA-00013781: <ul style="list-style-type: none"> ◦ In section 2.1, Shipping and crate configurations, the Safety table now includes a caution requiring two people to lift the magnet lifting rails and a warning against using damaged mounting hardware. ◦ In section 2.7, Removing the shipping crate, added step 15, a procedure about examining witness marks before lifting with the orange rails. A note referring to this new step was added in the following locations: <ul style="list-style-type: none"> • Section 2.8, Unloading and moving the uncrated magnet with a forklift, before step 1. • Section 2.9, Unloading the uncrated magnet with a crane to ground, before step 3. • Section 2.10, Lifting the magnet with a crane through the opening in the exterior wall, before step 4. • In section 2.1, Shipping and crate configurations: <ul style="list-style-type: none"> ◦ In the Safety table, "(if used)" was added after two "spreader beam" references. ◦ For the Domestic Shipping Crate (5151624), changed "Not approved for flight usage." to "Not approved for flight or ocean usage." For the Platform International Shipping Crate (5806856), changed "Approved for use on truck or air transportation." to "Approved for use on truck, ocean, or air transportation." • In section 2.2, Equipment requirements, in Table 2-2 Crane requirements, "(if used)" was added after "Spreader beam quantity". • In section 2.4, Handling the crated magnet in transit with a crane, added the statement "Using a crane requires clear access to the orange lifting beams, which are not accessible while the magnet is inside the crate." • The notice in section 2.6, Removing the shipping cage, about improper removal of the shipping cage had incorrect language referencing the crate. To fix this, the following changes were made: <ul style="list-style-type: none"> ◦ The notice, as is, was added to section 2.7, Removing the shipping crate, and the first and only instance of "cage" was changed to "crate". ◦ In section 2.6, the last two points were removed, as they only apply to the crate, and the remaining instances of "crate" were changed to "cage". • In section 2.6, Removing the shipping cage: <ul style="list-style-type: none"> ◦ Updated callout 3 in the second notice from "Crate" to "Cage". ◦ Added steps 1 and 2 about removing the tarp, unstrapping the cage, and unchaining the magnet.

Revision	Date	Description
		<ul style="list-style-type: none"> • In section 2.7, Removing the shipping crate, added a note to step 7 to clarify that the use of the spreader beam shown in the figure is optional. • In section 2.9, Unloading the uncrated magnet with a crane to ground: <ul style="list-style-type: none"> ◦ Added an equipment damage notice to the Safety table about improper crane transportation. ◦ Added a note about rigger responsibilities after the Safety table. ◦ Updated step 2. Changed "spreader beam" to "spreader beam (if used)"; added a sentence about what to do if a spreader beam is not used; added a note about spreader beam alignment; and added a figure showing the crane lift configuration. • Added section 2.10, Lifting the magnet with a crane through the opening in the exterior wall. • In section 3.1, Connecting the magnet to the compressor: <ul style="list-style-type: none"> ◦ Added an electric shock warning that includes LOTO to the Safety table. ◦ Removed step 4 (Make sure that the default coldhead frequency is 60 Hz. FE or warehouse staff must not change this.), since the default frequency is not editable. ◦ In step 4, corrected a typo. Changed "model" to "mode". ◦ For the figure <i>F50SH compressor unit, front view</i>, updated callout 13 to reference MM4 instead of MM3. ◦ Updated the figure <i>Coldhead compressor connections</i> to show the 3.0T coldhead motor for the AR series instead of the 1.5T coldhead motor for the PM series. • In section 3.2, Connecting the magnet monitoring connections: <ul style="list-style-type: none"> ◦ Added step 1 and the preceding paragraph to make sure cables are not damaged. ◦ In step 2, removed the beginning phrase "If the back office connection is available and working". The cable should always be connected. ◦ In step 3, removed the phrase "as shown below" since the associated figure is showing a part and not the entirety of the step. • In section 3.3, Monitoring the magnet, updated step 3b to refer to the <i>Magnet Monitor 4 Operating and Service Manual</i> (5804162) for setting parameters. Also added a note about Magnet Monitor 4 Storage mode. • In section 4.1, Preparing to do an in-transit helium refill, removed the text "In-transit helium refill is done based upon the magnet shipping date per the documents stated in the notice above. Access the plumbing through the access panels identified in the illustration below." and the <i>Crate access panels</i> figure. This information is not necessary to handle the magnet in transit. • In section 5.1, Preparing the scan room for leveling an AR series magnet, the figures <i>Isocenter location and z-axis vector</i> and <i>Isocenter location and vent pipe location</i> in step 1 were updated to match the <i>Preinstallation Manual</i>.

Revision	Date	Description
		<ul style="list-style-type: none"> • In sections 6.3 and 7.3, Preparing to move the magnet: <ul style="list-style-type: none"> ◦ Updated the clearance dimension tables from a generic column of dimensions to specific dimensions for SIGNA Hero versus SIGNA Premier. ◦ Updated clearance dimension A from 2,325 mm (91.54 inches) to 2250 mm (88.58 inches); B from 2,289 mm (90.12 inches) to 2289 mm (90.10 inches); C from 194.25 mm (7.67 inches) to 193 mm (7.60 inches); D from 2,140 mm (84.25 inches) to 2140 mm (84.3 inches); and E from 2,387 mm (94.00 inches) to 2388 mm (94.00 inches). • In section 6.6, Lowering the magnet into position, in step 9 changed "...until all feet are on the floor." to "until all feet are on the vibroacoustic mats." • In sections 6.7 and 7.6, Adding leveling shims, updated the figure <i>Shim arrangement</i> to show the leveling shims. • In sections 6.8 and 7.7, Leveling an AR series magnet, the step 6 acceptability statement was updated from "four of the six leveling markers" to "three of the four side leveling markers" and an additional statement "For seismic installations, the markers in the 12 o'clock position are not used." was added. • In section 7.5, Lowering the magnet into position, simplified step 3 to read "align centered ± 3 mm (± 0.125 inches) over the seismic anchor holes in the vibroacoustic mats." • In Chapter 8, Centering the table dock bolt for an AR series magnet, a note was added to step 6 about where to reference further information about dock anchor construction requirements. • Appendix B, Preinstallation Manual reference, was updated with a note to clarify that the table does not contain an exhaustive list of all product systems.
3	April 2022	Corrected revision number on front page. Content remains unchanged.
2	February 2022	MEP Information added in MyWorkshop. Content remains unchanged.
1	January 2022	Initial release of content specific to the AR magnet series.

Page intentionally left blank



GE HealthCare

www.gehealthcare.com