

# Innova™ IGS 5

## Pre-Installation Manual



5813633-8EN  
Revision 4  
© 2023 General Electric Company  
All rights reserved.



# Important...X-Ray Protection



X-ray equipment if not properly used may cause injury. Accordingly, the instructions herein contained should be thoroughly read and understood by everyone who will use the equipment before you attempt to place this equipment in operation. The General Electric Company, Healthcare Technologies, will be glad to assist and cooperate in placing this equipment in use.

Although this apparatus incorporates a high degree of protection against x-radiation other than the useful beam, no practical design of equipment can provide complete protection. Nor can any practical design compel the operator to take adequate precautions to prevent the possibility of any persons carelessly exposing themselves or others to radiation.

It is important that anyone having anything to do with x-radiation be properly trained and fully acquainted with the recommendations of the National Council on Radiation Protection and Measurements as published in NCRP Reports available from NCRP Publications, 7910 Woodmont Avenue, Room 1016, Bethesda, Maryland 20814, and of the International Commission on Radiation Protection, and take adequate steps to protect against injury.

The equipment is sold with the understanding that the General Electric Company, Healthcare Technologies, its agents, and representatives have no responsibility for injury or damage which may result from improper use of the equipment. Various protective materials and devices are available. It is urged that such materials or devices be used.

# Language Policy

## Direction 2128126 - Language Policy For Service Documentation

ПРЕДУПРЕЖ ДЕНИЕ (BG)	<p>Това упътване за работа е налично само на английски език.</p> <ul style="list-style-type: none"><li>Ако доставчикът на услугата на клиента изиска друг език, задължение на клиента е да осигури превод.</li><li>Не използвайте оборудването, преди да сте се консултирали и разбрали упътването за работа.</li><li>Неспазването на това предупреждение може да доведе до нараняване на доставчика на услугата, оператора или пациента в резултат на токов удар, механична или друга опасност.</li></ul>
警告 (ZH-CN)	<p>本维修手册仅提供英文版本。</p> <ul style="list-style-type: none"><li>如果客户的维修服务人员需要非英文版本，则客户需自行提供翻译服务。</li><li>未详细阅读和完全理解本维修手册之前，不得进行维修。</li><li>忽略本警告可能对维修服务人员、操作人员或患者造成电击、机械伤害或其他形式的伤害。</li></ul>
警告 (ZH-HK)	<p>本服務手冊僅提供英文版本。</p> <ul style="list-style-type: none"><li>倘若客戶的服務供應商需要英文以外之服務手冊，客戶有責任提供翻譯服務。</li><li>除非已參閱本服務手冊及明白其內容，否則切勿嘗試維修設備。</li><li>不遵從本警告或會令服務供應商、網絡供應商或病人受到觸電、機械性或其他危險。</li></ul>
警告 (ZH-TW)	<p>本維修手冊僅有英文版。</p> <ul style="list-style-type: none"><li>若客戶的維修廠商需要英文版以外的語言，應由客戶自行提供翻譯服務。</li><li>請勿試圖維修本設備，除非您已查閱並瞭解本維修手冊。</li><li>若未留意本警告，可能導致維修廠商、操作員或病患因觸電、機械或其他危險而受傷。</li></ul>
UPOZOR- ENJE (HR)	<p>Ovaj servisni priručnik dostupan je na engleskom jeziku.</p> <ul style="list-style-type: none"><li>Ako davatelj usluge klijenta treba neki drugi jezik, klijent je dužan osigurati prijevod.</li><li>Ne pokušavajte servisirati opremu ako niste u potpunosti pročitali i razumjeli ovaj servisni priručnik.</li><li>Zanemarite li ovo upozorenje, može doći do ozljede davatelja usluge, operatera ili pacijenta uslijed strujnog udara, mehaničkih ili drugih rizika.</li></ul>
VÝSTRAHA (CS)	<p>Tento provozní návod existuje pouze v anglickém jazyce.</p> <ul style="list-style-type: none"><li>V případě, že externí služba zákazníkům potřebuje návod v jiném jazyce, je zajištění překladu do odpovídajícího jazyka úkolem zákazníka.</li><li>Nesnažte se o údržbu tohoto zařízení, aniž byste si přečetli tento provozní návod a pochopili jeho obsah.</li><li>V případě nedodržování této výstrahy může dojít k poranění pracovníka prodejního servisu, obslužného personálu nebo pacientů vlivem elektrického proudu, respektive vlivem mechanických či jiných rizik.</li></ul>

ADVARSEL (DA)	<p>Denne servicemanual findes kun på engelsk.</p> <ul style="list-style-type: none"> <li>• Hvis en kundes tekniker har brug for et andet sprog end engelsk, er det kundens ansvar at sørge for oversættelse.</li> <li>• Forsøg ikke at servicere udstyret uden at læse og forstå denne servicemanual.</li> <li>• Manglende overholdelse af denne advarsel kan medføre skade på grund af elektrisk stød, mekanisk eller anden fare for teknikeren, operatøren eller patienten.</li> </ul>
WAAR-SCHUWING (NL)	<p>Deze onderhoudshandleiding is enkel in het Engels verkrijgbaar.</p> <ul style="list-style-type: none"> <li>• Als het onderhoudspersoneel een andere taal vereist, dan is de klant verantwoordelijk voor de vertaling ervan.</li> <li>• Probeer de apparatuur niet te onderhouden alvorens deze onderhoudshandleiding werd geraadpleegd en begrepen is.</li> <li>• Indien deze waarschuwing niet wordt opgevolgd, zou het onderhoudspersoneel, de operator of een patiënt gewond kunnen raken als gevolg van een elektrische schok, mechanische of andere gevaren.</li> </ul>
WARNING (EN)	<p>This service manual is available in English only.</p> <ul style="list-style-type: none"> <li>• If a customer's service provider requires a language other than English, it is the customer's responsibility to provide translation services.</li> <li>• Do not attempt to service the equipment unless this service manual has been consulted and is understood.</li> <li>• Failure to heed this warning may result in injury to the service provider, operator or patient from electric shock, mechanical or other hazards.</li> </ul>
HOIATUS (ET)	<p>See teenindusjuhend on saadaval ainult inglise keeles.</p> <ul style="list-style-type: none"> <li>• Kui klienditeeninduse osutaja nõuab juhendit inglise keelest erinevas keeles, vastutab klient tõlketeenuse osutamise eest.</li> <li>• Ärge üritage seadmeid teenindada enne eelnevalt käesoleva teenindusjuhendiga tutvumist ja sellest aru saamist.</li> <li>• Käesoleva hoiatuse eiramine võib põhjustada teenuseosutaja, operaatori või patsiendi vigastamist elektrilöögi, mehaanilise või muu ohu tagajärjel.</li> </ul>
VAROITUS (FI)	<p>Tämä huolto-ohje on saatavilla vain englanniksi.</p> <ul style="list-style-type: none"> <li>• Jos asiakkaan huoltohenkilöstö vaatii muuta kuin englanninkielistä materiaalia, tarvittavan käännöksen hankkiminen on asiakkaan vastuulla.</li> <li>• Älä yritä korjata laitteistoa ennen kuin olet varmasti lukenut ja ymmärtänyt tämän huolto-ohjeen.</li> <li>• Mikäli tätä varoitusta ei noudateta, seurauksena voi olla huoltohenkilöstön, laitteiston käyttäjän tai potilaan vahingoittuminen sähköiskun, mekaanisen vian tai muun vaaratilanteen vuoksi.</li> </ul>

<p>ATTENTION (FR)</p>	<p>Ce manuel d'installation et de maintenance est disponible uniquement en anglais.</p> <ul style="list-style-type: none"> <li>• Si le technicien d'un client a besoin de ce manuel dans une langue autre que l'anglais, il incombe au client de le faire traduire.</li> <li>• Ne pas tenter d'intervenir sur les équipements tant que ce manuel d'installation et de maintenance n'a pas été consulté et compris.</li> <li>• Le non-respect de cet avertissement peut entraîner chez le technicien, l'opérateur ou le patient des blessures dues à des dangers électriques, mécaniques ou autres.</li> </ul>
<p>WARNUNG (DE)</p>	<p>Diese Serviceanleitung existiert nur in englischer Sprache.</p> <ul style="list-style-type: none"> <li>• Falls ein fremder Kundendienst eine andere Sprache benötigt, ist es Aufgabe des Kunden für eine entsprechende Übersetzung zu sorgen.</li> <li>• Versuchen Sie nicht diese Anlage zu warten, ohne diese Serviceanleitung gelesen und verstanden zu haben.</li> <li>• Wird diese Warnung nicht beachtet, so kann es zu Verletzungen des Kundendiensttechnikers, des Bedieners oder des Patienten durch Stromschläge, mechanische oder sonstige Gefahren kommen.</li> </ul>
<p>ΠΡΟΕΙΔΟΠΟΙΗΣΗ (EL)</p>	<p>Το παρόν εγχειρίδιο σέρβις διατίθεται στα αγγλικά μόνο.</p> <ul style="list-style-type: none"> <li>• Εάν το άτομο παροχής σέρβις ενός πελάτη απαιτεί το παρόν εγχειρίδιο σε γλώσσα εκτός των αγγλικών, αποτελεί ευθύνη του πελάτη να παρέχει υπηρεσίες μετάφρασης.</li> <li>• Μηνεπιχειρήσετε την εκτέλεση εργασιών σέρβις στον εξοπλισμό εκτός εάν έχετε συμβουλευτεί και έχετε κατανοήσει το παρόν εγχειρίδιο σέρβις.</li> <li>• Εάν δεν λάβετε υπόψη την προειδοποίηση αυτή, ενδέχεται να προκληθεί τραυματισμός στο άτομο παροχής σέρβις, στο χειριστή ή στον ασθενή από ηλεκτροπληξία, μηχανικούς ή άλλους κινδύνους.</li> </ul>
<p>FIGYELMEZTETÉS (HU)</p>	<p>Ezen karbantartási kézikönyv kizárólag angol nyelven érhető el.</p> <ul style="list-style-type: none"> <li>• Ha a vevő szolgáltatója angoltól eltérő nyelvre tart igényt, akkor a vevő felelőssége a fordítás elkészítése.</li> <li>• Ne próbálja elkezdni használni a berendezést, amíg a karbantartási kézikönyvben leírtakat nem értelmezték.</li> <li>• Ezen figyelmeztetés figyelmen kívül hagyása a szolgáltató, működtető vagy a beteg áramütés, mechanikai vagy egyéb veszélyhelyzet miatti sérülését eredményezheti.</li> </ul>
<p>AÐVÖRUN (IS)</p>	<p>Þessi þjónustuhandbók er aðeins fánleg á ensku.</p> <ul style="list-style-type: none"> <li>• Ef að þjónustuveitandi viðskiptamanns þarfnast annas tungumáls en ensku, er það skylda viðskiptamanns að skaffa tungumálþjónustu.</li> <li>• Reynið ekki að afgreiða tækið nema að þessi þjónustuhandbók hefur verið skoðuð og skilin.</li> <li>• Brot á sinna þessari aðvörun getur leitt til meiðsla á þjónustuveitanda, stjórnanda eða sjúklings frá raflosti, vélrænu eða öðrum áhættum.</li> </ul>

AVVERTENZA (IT)	<p>Il presente manuale di manutenzione è disponibile soltanto in lingua inglese.</p> <ul style="list-style-type: none"> <li>• Se un addetto alla manutenzione richiede il manuale in una lingua diversa, il cliente è tenuto a provvedere direttamente alla traduzione.</li> <li>• Procedere alla manutenzione dell'apparecchiatura solo dopo aver consultato il presente manuale ed averne compreso il contenuto.</li> <li>• Il mancato rispetto della presente avvertenza potrebbe causare lesioni all'addetto alla manutenzione, all'operatore o ai pazienti provocate da scosse elettriche, urti meccanici o altri rischi.</li> </ul>
警告 (JA)	<p>このサービスマニュアルには英語版しかありません。</p> <ul style="list-style-type: none"> <li>• サービスを担当される業者が英語以外の言語を要求される場合、翻訳作業はその業者の責任で行うものとさせていただきます。</li> <li>• このサービスマニュアルを熟読し理解せずに、装置のサービスを行わないでください。</li> <li>• この警告に従わない場合、サービスを担当される方、操作員あるいは患者さんが、感電や機械的又はその他の危険により負傷する可能性があります。</li> </ul>
경고 (KO)	<p>본 서비스 매뉴얼은 영어로만 이용하실 수 있습니다.</p> <ul style="list-style-type: none"> <li>• 고객의 서비스 제공자가 영어 이외의 언어를 요구할 경우, 번역 서비스를 제공하는 것은 고객의 책임입니다.</li> <li>• 본 서비스 매뉴얼을 참조하여 숙지하지 않은 이상 해당 장비를 수리하려고 시도하지 마십시오.</li> <li>• 본 경고 사항에 유의하지 않으면 전기 쇼크, 기계적 위험, 또는 기타 위험으로 인해 서비스 제공자, 사용자 또는 환자에게 부상을 입힐 수 있습니다.</li> </ul>
BRĪDINĀ- JUMS (LV)	<p>Šī apkopes rokasgrāmata ir pieejama tikai angļu valodā.</p> <ul style="list-style-type: none"> <li>• Ja klienta apkopes sniedzējam nepieciešama informācija citā valodā, klienta pienākums ir nodrošināt tulkojumu.</li> <li>• Neveiciet aprīkojuma apkopi bez apkopes rokasgrāmatas izlasīšanas un saprašanas.</li> <li>• Šī brīdinājuma neievērošanas rezultātā var rasties elektriskās strāvas trieciena, mehānisku vai citu faktoru izraisītu traumu risks apkopes sniedzējam, operatoram vai pacientam.</li> </ul>
ĮSPĖJIMAS (LT)	<p>Šis eksploataavimo vadovas yra tik anglų kalba.</p> <ul style="list-style-type: none"> <li>• Jei kliento paslaugų tiekėjas reikalauja vadovo kita kalba – ne anglų, suteikti vertimo paslaugas privalo klientas.</li> <li>• Nemėginkite atlikti įrangos techninės priežiūros, jei neperskaitėte ar nesupratote šio eksploataavimo vadovo.</li> <li>• Jei nepaisysite šio įspėjimo, galimi paslaugų tiekėjo, operatoriaus ar paciento sužalojimai dėl elektros šoko, mechaninių ar kitų pavojų.</li> </ul>
ADVARSEL (NO)	<p>Denne servicehåndboken finnes bare på engelsk.</p> <ul style="list-style-type: none"> <li>• Hvis kundens serviceleverandør har bruk for et annet språk, er det kundens ansvar å sørge for oversettelse.</li> <li>• Ikke forsøk å reparere utstyret uten at denne servicehåndboken er lest og forstått.</li> <li>• Manglende hensyn til denne advarselen kan føre til at serviceleverandøren, operatøren eller pasienten skades på grunn av elektrisk støt, mekaniske eller andre farer.</li> </ul>

<p>OSTRZEŻENIE (PL)</p>	<p>Niniejszy podręcznik serwisowy dostępny jest jedynie w języku angielskim.</p> <ul style="list-style-type: none"> <li>• Jeśli serwisant klienta wymaga języka innego niż angielski, zapewnienie usługi tłumaczenia jest obowiązkiem klienta.</li> <li>• Nie próbować serwisować urządzenia bez zapoznania się z niniejszym podręcznikiem serwisowym i zrozumienia go.</li> <li>• Niezastosowanie się do tego ostrzeżenia może doprowadzić do obrażeń serwisanta, operatora lub pacjenta w wyniku porażenia prądem elektrycznym, zagrożenia mechanicznego bądź innego.</li> </ul>
<p>ATENÇÃO (PT-BR)</p>	<p>Este manual de assistência técnica encontra-se disponível unicamente em inglês.</p> <ul style="list-style-type: none"> <li>• Se outro serviço de assistência técnica solicitar a tradução deste manual, caberá ao cliente fornecer os serviços de tradução.</li> <li>• Não tente reparar o equipamento sem ter consultado e compreendido este manual de assistência técnica.</li> <li>• A não observância deste aviso pode ocasionar ferimentos no técnico, operador ou paciente decorrentes de choques elétricos, mecânicos ou outros.</li> </ul>
<p>ATENÇÃO (PT-PT)</p>	<p>Este manual de assistência técnica só se encontra disponível em inglês.</p> <ul style="list-style-type: none"> <li>• Se qualquer outro serviço de assistência técnica solicitar este manual noutro idioma, é da responsabilidade do cliente fornecer os serviços de tradução.</li> <li>• Não tente reparar o equipamento sem ter consultado e compreendido este manual de assistência técnica.</li> <li>• O não cumprimento deste aviso pode colocar em perigo a segurança do técnico, do operador ou do paciente devido a choques eléctricos, mecânicos ou outros.</li> </ul>
<p>ATENȚIE (RO)</p>	<p>Acest manual de service este disponibil doar în limba engleză.</p> <ul style="list-style-type: none"> <li>• Dacă un furnizor de servicii pentru clienți necesită o altă limbă decât cea engleză, este de datoria clientului să furnizeze o traducere.</li> <li>• Nu încercați să reparați echipamentul decât ulterior consultării și înțelegerii acestui manual de service.</li> <li>• Ignorarea acestui avertisment ar putea duce la rănirea depanatorului, operatorului sau pacientului în urma pericolelor de electrocutare, mecanice sau de altă natură.</li> </ul>
<p>ОСТОРОЖНО! (RU)</p>	<p>Данное руководство по техническому обслуживанию представлено только на английском языке.</p> <ul style="list-style-type: none"> <li>• Если сервисному персоналу клиента необходимо руководство не на английском, а на каком-то другом языке, клиенту следует самостоятельно обеспечить перевод.</li> <li>• Перед техническим обслуживанием оборудования обязательно обратитесь к данному руководству и поймите изложенные в нем сведения.</li> <li>• Несоблюдение требований данного предупреждения может привести к тому, что специалист по техобслуживанию, оператор или пациент получит удар электрическим током, механическую травму или другое повреждение.</li> </ul>

UPOZOR- ENJE (SR)	<p>Ovo servisno uputstvo je dostupno samo na engleskom jeziku.</p> <ul style="list-style-type: none"> <li>• Ako klijentov serviser zahteva neki drugi jezik, klijent je dužan da obezbedi prevodilačke usluge.</li> <li>• Ne pokušavajte da opravite uređaj ako niste pročitali i razumeli ovo servisno uputstvo.</li> <li>• Zanemarivanje ovog upozorenja može dovesti do povređivanja serviser, rukovaoca ili pacijenta usled strujnog udara ili mehaničkih i drugih opasnosti.</li> </ul>
UPOZORNE- NIE (SK)	<p>Tento návod na obsluhu je k dispozícii len v angličtine.</p> <ul style="list-style-type: none"> <li>• Ak zákazníkovi poskytovateľ služieb vyžaduje iný jazyk ako angličtinu, poskytnutie prekladateľských služieb je zodpovednosťou zákazníka.</li> <li>• Nepokúšajte sa o obsluhu zariadenia, kým si neprečítate návod na obsluhu a neporozumiete mu.</li> <li>• Zanedbanie tohto upozornenia môže spôsobiť zranenie poskytovateľa služieb, obsluhujúcej osoby alebo pacienta elektrickým prúdom, mechanické alebo iné ohrozenie.</li> </ul>
ATENCION (ES)	<p>Este manual de servicio sólo existe en inglés.</p> <ul style="list-style-type: none"> <li>• Si el encargado de mantenimiento de un cliente necesita un idioma que no sea el inglés, el cliente deberá encargarse de la traducción del manual.</li> <li>• No se deberá dar servicio técnico al equipo, sin haber consultado y comprendido este manual de servicio.</li> <li>• La no observancia del presente aviso puede dar lugar a que el proveedor de servicios, el operador o el paciente sufran lesiones provocadas por causas eléctricas, mecánicas o de otra naturaleza.</li> </ul>
VARNING (SV)	<p>Den här servicehandboken finns bara tillgänglig på engelska.</p> <ul style="list-style-type: none"> <li>• Om en kunds servicetekniker har behov av ett annat språk än engelska, ansvarar kunden för att tillhandahålla översättningstjänster.</li> <li>• Försök inte utföra service på utrustningen om du inte har läst och förstår den här servicehandboken.</li> <li>• Om du inte tar hänsyn till den här varningen kan det resultera i skador på serviceteknikern, operatören eller patienten till följd av elektriska stötar, mekaniska faror eller andra faror.</li> </ul>
OPOZORILO (SL)	<p>Ta servisni priročnik je na voljo samo v angleškem jeziku.</p> <ul style="list-style-type: none"> <li>• Če ponudnik storitve stranke potrebuje priročnik v drugem jeziku, mora stranka zagotoviti prevod.</li> <li>• Ne poskušajte servisirati opreme, če tega priročnika niste v celoti prebrali in razumeli.</li> <li>• Če tega opozorila ne upoštevate, se lahko zaradi električnega udara, mehanskih ali drugih nevarnosti poškoduje ponudnik storitev, operater ali bolnik.</li> </ul>

<p>DİKKAT (TR)</p>	<p>Bu servis kılavuzunun sadece İngilizcesi mevcuttur.</p> <ul style="list-style-type: none"> <li>• Eğer müşteri teknisyeni bu kılavuzu İngilizce dışında bir başka lisandan talep ederse, bunu tercüme ettirmek müşteriye düşer.</li> <li>• Servis kılavuzunu okuyup anlamadan ekipmanlara müdahale etmeyiniz.</li> <li>• Bu uyarıya uyulmaması, elektrik, mekanik veya diğer tehlikelerden dolayı teknisyen, operatör veya hastanın yaralanmasına yol açabilir.</li> </ul>
<p>ЗАСТЕРЕЖЕННЯ (UK)</p>	<p>Даний посібник з експлуатації доступний тільки англійською мовою.</p> <ul style="list-style-type: none"> <li>• Якщо постачальник послуг клієнта спілкується іноземною мовою, тоді клієнт зобов'язаний забезпечити переклад.</li> <li>• Заборонено проводити огляд обладнання без попереднього звертання до даного посібника з експлуатації і розуміння інформації, поданої у ньому.</li> <li>• Недотримання цього застереження може завдати шкоди здоров'ю постачальника послуг, оператора або пацієнта через ураження електричним струмом, механічну травму або інше ушкодження.</li> </ul>

# Revision History

<b>Part/Rev</b>	<b>Date</b>	<b>Reason for Change</b>
5813633-8EN Rev 1	2019-10	Initial release of direction 5813633-8EN
5813633-8EN Rev 2	2020-01	Release after Service Validation
5813633-8EN Rev 3	2020-10	Third release of direction 5813633-8EN
5813633-8EN Rev 4	2023-04	Fourth release of direction 5813633-8EN Introduction of the Large Display Monitor 55".

Page intentionally left blank

# Contents

<b>Chapter 1 General Requirements</b>	<b>1</b>
1.1 Objectives & Overview	1
1.1.1 Object and Scope of this manual	1
1.1.2 Pre-Installation Process	1
1.2 Customer Responsibilities	2
1.2.1 Responsibilities of the Purchaser/Customer	2
1.2.2 Equipment Classifications	3
1.2.3 Pre-Installation Checklist	5
1.3 Delivery Requirements	5
1.3.1 Shipping Information	5
1.3.2 Tools and Test Equipment	19
1.3.3 Door Size Requirements	21
1.3.4 Route Survey	22
1.4 Product Storage and Handling Requirement	24
1.4.1 Post-delivery warm up period	24
1.4.2 System Storage	25
1.4.3 Handling instructions	26
<b>Chapter 2 Equipment Requirements</b>	<b>29</b>
2.1 System Components	29
2.1.1 Presentation of the 3 Rooms	29
2.1.2 Description of the System	30
2.1.3 Dimension Drawings	49
2.2 Room Layouts	94
2.2.1 Room Dimension Requirements	94
2.2.2 Room Layout Drawings	96
2.2.3 Room Layout Considerations	111
2.3 Room Structural Requirements	113
2.3.1 General Policy	113
2.3.2 Floor Requirements	116
2.3.3 Mounting Requirements	121
2.3.4 Ceiling Requirements	130
2.3.5 Wall Requirements	136
2.4 Seismic	136
2.4.1 Seismic areas	137
2.4.2 Center of Gravity	137
<b>Chapter 3 Special Construction Requirements</b>	<b>139</b>
3.1 Radiation Protection	139
3.2 EMI Consideration	139

3.2.1 General Scope . . . . .	139
3.2.2 Electromagnetic Emission . . . . .	139
3.2.3 Electromagnetic Immunity . . . . .	140
3.2.4 Limitations Management . . . . .	145
3.2.5 Installations Requirements & Environment Control . . . . .	146
<b>Chapter 4 Environmental Requirements . . . . .</b>	<b>147</b>
4.1 Humidity, Temperature and Altitude . . . . .	147
4.2 Heat Output . . . . .	149
4.3 Acoustic Specifications . . . . .	150
4.4 Room Light . . . . .	150
<b>Chapter 5 Electrical Requirements . . . . .</b>	<b>153</b>
5.1 System Electrical Ratings . . . . .	153
5.1.1 Electrical Ratings . . . . .	153
5.1.2 Additional Transformer characteristics . . . . .	153
5.1.3 Additional Full UPS . . . . .	154
5.2 Power Distribution Schematics . . . . .	154
5.3 Grounding Schematics . . . . .	158
5.4 Mains Disconnect Panel . . . . .	160
5.4.1 General Information . . . . .	160
5.4.2 Mandatory Construction Requirements . . . . .	161
5.4.3 Mandatory EPO Requirements . . . . .	162
5.4.4 Mandatory LOTO Requirements . . . . .	163
5.4.5 Cabling Requirements . . . . .	163
5.4.6 Mandatory Labeling Requirements . . . . .	164
5.4.7 Other Mandatory Requirements . . . . .	165
5.4.8 Preferred Schematics and Components . . . . .	165
5.4.9 Checklist . . . . .	170
5.5 External Interfaces . . . . .	171
5.6 Third-Party Monitor Suspension Typical Connections . . . . .	178
5.7 System Cable Information . . . . .	180
5.7.1 Physical Runs . . . . .	180
5.7.2 MIS (Master Interconnect System) . . . . .	196
5.7.3 Cable Channeling . . . . .	197
<b>Chapter 6 Communication Requirements . . . . .</b>	<b>201</b>
6.1 Network Requirements . . . . .	201
6.2 DICOM Requirements . . . . .	203
6.3 Privacy and Security Configuration . . . . .	204

# Chapter 1 General Requirements

## 1.1 Objectives & Overview

### 1.1.1 Object and Scope of this manual

#### 1.1.1.1 Object and Scope

In this manual:

- The name "Innova™ IGS 5" is used to designate indifferently Innova™ IGS 5 or Innova™ IGS 3. In this case, the procedure and/or tests are applicable indifferently to both products,
- The term "IGS system" refers to Innova™ IGS 5 and Innova™ IGS 3 product models.

This document is intended as a guide and information resource to properly plan and prepare a site for the installation of an IGS system.

In addition, this document provides references to the pre-installation documents of the various product included with the System.

These documents are intended to assist the Project Manager of Installation (PMI) and the Site Planner in properly preparing a site for the installation of this system.

It provides pre-installation data, such as site preparation prior to the delivery of the System, environmental and electrical requirements and some additional planning aids.



MAKE SURE THE ROOM PREPARATION COMPLIES WITH LOCAL REGULATIONS  
AS THE PIM IS NOT INTENDED TO REFLECT ALL OF THEM.

#### 1.1.1.2 Quebec

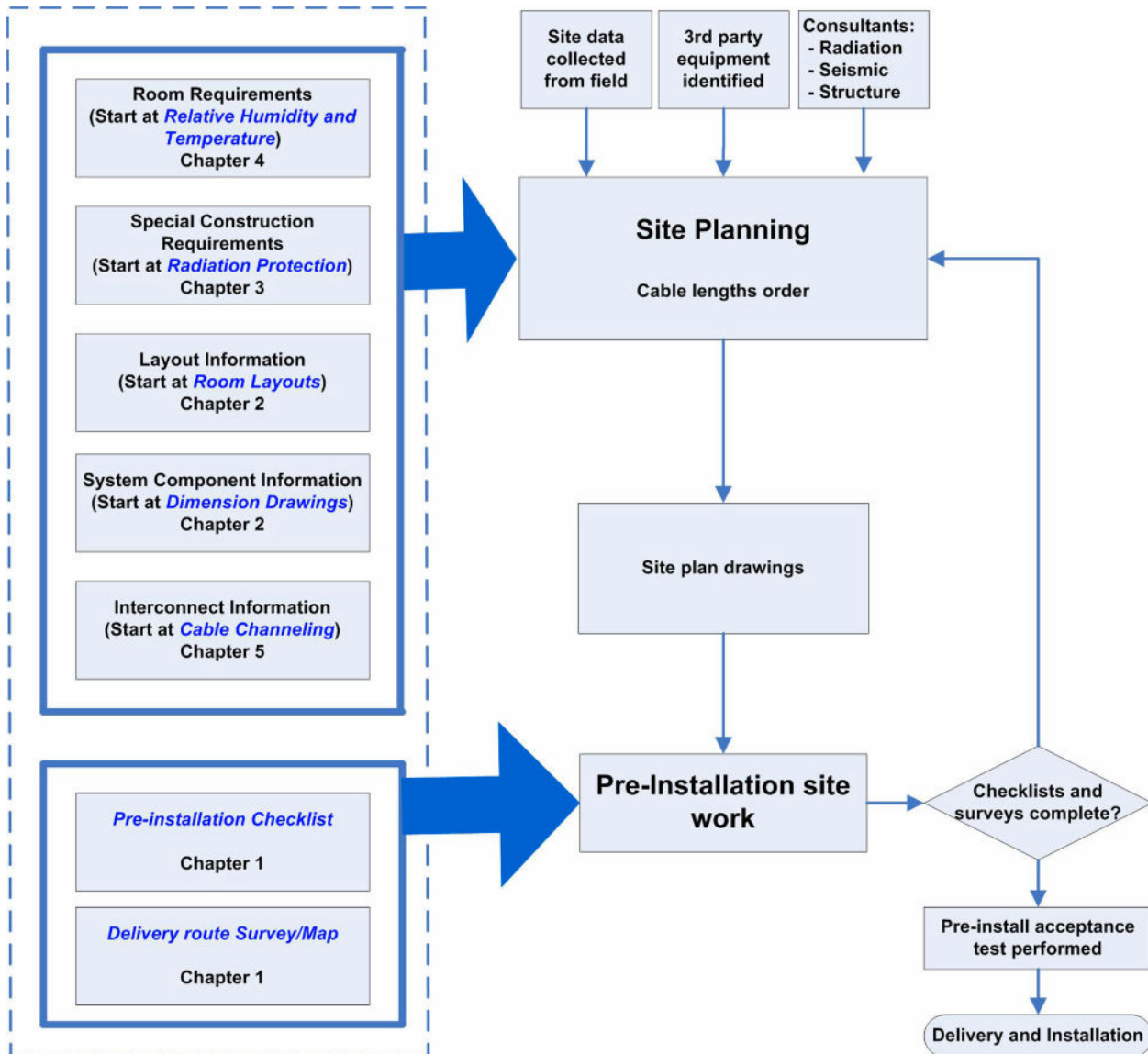
GE Healthcare is "GE Santé" in Province of Quebec - Canada.

### 1.1.2 Pre-Installation Process

Complete the checklists in ROOM LAYOUTS, ELECTRICAL REQUIREMENTS, and GENERAL REQUIREMENTS of this manual. They represent an important part of the pre-installation process. The checklists summarize the required preparations and allow to verify the proper completion of the pre-installation procedures.

You will find hereafter a chart of the information flow in the pre-installation process.

Figure 1



## 1.2 Customer Responsibilities

### 1.2.1 Responsibilities of the Purchaser/Customer

To ensure that the installation of an Innova System meets the purchaser or customer expectations, it is important to determine who will take responsibility for the various items during the system installation process. To help you in determining these responsibilities, review the following checklists with the customer and assign responsibilities as appropriate:

- Tools and Test Equipment
- Pre-Installation Checklist.

### Contract Changes:

Be sure to inform the customer that the cost of any alteration or modification not specified in the sales contract are liable to the customer.

The following equipment must be installed by the Hospital's Contractors, per room drawings:

#### 1. GE-supplied equipment:

- Gantry and Table baseplate with holes drilled (Per supplied template)
- Gantry and Table baseplate grout
- Gantry and Table baseplate floor anchors
- **(For Suspension with rails)** Monitor suspension stationary rails
- **(For Suspension with fixed point Dual Arm)** Substructure for Dual Arm Suspension (S18391MX)

#### **NOTE**

Means necessary to anchor of the Substructure for Dual Arm suspension (anchors, bolts, screws, etc.) are not delivered with the kit and should be provided and designed under customer responsibility.

#### 2. Customer supplied equipment:



- MDP (Mains Disconnect Panel)
- Power cables MDP-PDU
- EPO cable MDP-PDU
- Protective Earth cable MDP-PDU
- Power cable MDP-FUPS
- Power cable FUPS-PDU
- **(For Suspension with fixed point Dual Arm)** Means necessary to anchor of the Substructure for Dual Arm suspension (anchors, bolts, screws, etc.)
- Third-Party Monitor suspension

#### **NOTE**

In case of Innova<sup>IQ</sup> table upgrade, it is critical to have the table baseplate flushed in the concrete.

## 1.2.2 Equipment Classifications

The following equipment classifications are applicable to the product:

Classification category	Equipment classification
Protection against electric shock	<p>Class I</p>  <p>TO AVOID THE RISK OF ELECTRIC SHOCK, THIS EQUIPMENT MUST ONLY BE CONNECTED TO A SUPPLY MAINS WITH PROTECTIVE EARTH.</p>
Degree of protection against electric shock	<p>Type B applied parts</p>  <p>Applied parts complying with the specified requirements of the IEC 60601-1 standard to provide protection against electric shock, particularly regarding allowable patient leakage current and patient auxiliary current include:</p> <ul style="list-style-type: none"> <li>• Mattress</li> <li>• Table accessories: shoulder rest, foot rest, table head extender, Removable rails (sleeve), Head widener with pad/cushion, Width extender with pad/cushion, armboard with thick pad/cushion, rail extender and patient restraint strap with cushion.</li> </ul>
Degree of protection against harmful ingress of water	<p>Ordinary equipment (enclosed equipment without protection against ingress of water); except footswitch which is a watertight device (protected against the effects of submersion, IPX7/IPX8).</p>
Method(s) of sterilization or disinfection recommended by the manufacturer	<ul style="list-style-type: none"> <li>• Sterilization: not applicable</li> <li>• Disinfection: refer to Operator Manual (Chapter Safety and Regulatory, section Disinfection), Recommended disinfecting agents. The system does not fulfill the requirements for AP/APG classification (IEC 60601-1).</li> </ul>
Degree of safety of application in the presence of a flammable anesthetic mixture with air or with oxygen or nitrous oxide	<p>Equipment not suitable for use in the presence of a flammable anesthetic mixture with air or with oxygen or nitrous oxide</p>
Mode of operation	<p>Continuous operation with intermittent loading</p>



**NOTICE**

THE SYSTEM CAN ONLY BE INSTALLED IN AN ANESTHETIZING LOCATION IF THAT LOCATION IS CLASSIFIED AS OTHER THAN HAZARDOUS AS PER NFPA 70 CLAUSE 517.60.

**NOTICE**

THE PRODUCT IS NOT CLASSIFIED AS AP, APG (EQUIPMENT NOT SUITABLE FOR USE IN THE PRESENCE OF A FLAMMABLE ANAESTHETIC MIXTURE WITH AIR OR WITH OXYGEN OR NITROUS OXIDE).

## 1.2.3 Pre-Installation Checklist

Refer to the document *Global Site Readiness Checklist DI - DOC1809666* for standard HPM requirements on Room preparation for Vascular Systems installation.

See also the specific preparation requirements for IGS Systems installation given in sections 3, 4 and 5 of the Tab "Installation Prerequisites" in document *IGS System Installation Prerequisites - DOC2024755*.

**NOTE**

DOC1809666 and DOC2024755 are available from MyWorkshop.

## 1.3 Delivery Requirements

### 1.3.1 Shipping Information

#### 1.3.1.1 Product Shipping Information

Refer to the table below. To obtain shipping information for components not specified in the table, refer to the appropriate component Pre-Installation Manual.

**Table 1**

PRODUCT OR COMPONENT	DIMENSIONS			WEIGHT kg (lbs)	METHOD OF SHIPMENT
	Height mm (in)	Width mm (in)	Depth mm (in)		
Gantry	2000 (79)	1230 (48.4)	Delivered configuration: 2820 (111) On-site shortened configuration: 2300 (90)	1060 (2,340)	Shipping Dolly. For delivered configuration, see <a href="#">Figure 2 on page 8</a> For on-site shortened configuration, see <a href="#">Figure 3 on page 9</a>
	2300 (90.5)	1380 (54.5)	2900 (114)	1200 (2,645)	Air shipment. See <a href="#">Figure 4 on page 10</a>
C-FRT Cabinet	2200 (87)	1500 (59)	850 (34)	630 (1,388)	On pallet. See <a href="#">Figure 5 on page 11</a>

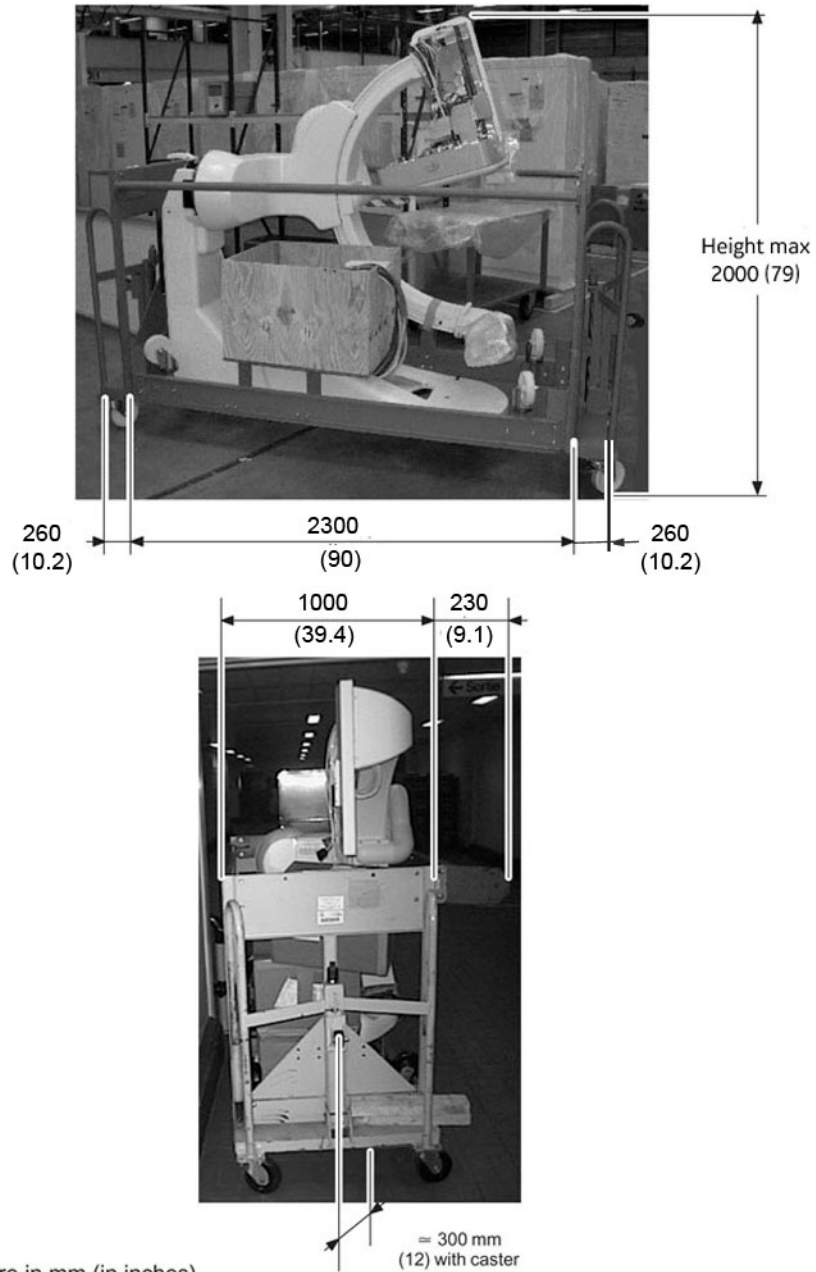
continued					
PRODUCT OR COMPONENT	DIMENSIONS			WEIGHT kg (lbs)	METHOD OF SHIPMENT
	Height mm (in)	Width mm (in)	Depth mm (in)		
NPA PDU	2020 (80)	985 (39)	567 (22)	380 (838)	On pallet. See <a href="#">Figure 6 on page 12</a>
Omega Table Base Assembly	1032 (41)	2060 (81)	840 (33)	585 (1,290)	On pallet. See <a href="#">Figure 7 on page 13</a>
Omega Table Top Assembly	220 (9)	3470 (137)	840 (33)	70 (155)	On pallet. See <a href="#">Figure 7 on page 13</a>
Innova <sup>IQ</sup> table Base Assembly and covers	1160 (45.7)	1000 (39.4)	2150 (84.6)	750 (1,653)	On pallet. See <a href="#">Figure 8 on page 14</a> and <a href="#">Figure 9 on page 15</a>
X-Ray Tube housing	960 (37.7)	770 (30.3)	710 (28)	113 (250)	On pallet
X-Ray Tube Chiller	1200 (47.2)	555 (21.8)	610 (24)	120 (264.5)	On pallet
Gantry Requisites	-	-	-	-	On pallet
Cables	-	-	-	-	On pallet
Monitor susp. bridge	640 (25.2)	980 (38.6)	3060 (120.5)	210 (445)	On pallet
Monitor susp. rails	380 (15)	300 (12)	5960 (235)	160 (355)	On pallet
Substructure for Dual Arm suspension (4 19" Monitors MAVIG suspension with fixed point dual arm)	330 (13)	1040 (41)	490 (19.3)	70 (154.3)	On pallet, see <a href="#">Figure 10 on page 16</a>
MAVIG suspension with fixed point dual arm for 4 19" Monitors	1860 (73.2)	2150 (84.6)	900 (35.4)	166 (366)	On pallet, see <a href="#">Figure 11 on page 17</a>
Large Display monitor	895 (35.2)	1390 (54.7)	275 (10.8)	45 (99.2)	On pallet
LD suspension with rails	1100 (43.3)	1100 (43.3)	1850 (72.8)	390 (860)	On pallet
LD suspension with rails 36 m harness	230 (9)	800 (34.5)	800 (34.5)	62 (134)	On pallet
Substructure for Dual Arm suspension (for Mavig suspension with fixed point dual arm for Large Display Monitor)	330 (13)	1040 (41)	490 (19.3)	70 (154.3)	On pallet, see <a href="#">Figure 10 on page 16</a>

continued					
PRODUCT OR COMPONENT	DIMENSIONS			WEIGHT kg (lbs)	METHOD OF SHIPMENT
	Height mm (in)	Width mm (in)	Depth mm (in)		
Mavig suspension with fixed point dual arm for Large Display Monitor	1860 (73.2)	2150 (84.6)	900 (35.4)	370 (815.7)	On pallet, see <a href="#">Figure 12 on page 18</a>
Fluoro UPS UL	2100 (82.7)	890 (35)	1000 (39.4)	561 (1,235)	On pallet
Fluoro UPS CE	1750 (68.9)	890 (35)	1000 (39.4)	585 (1,287)	On pallet

### 1.3.1.2 Detail of Shipping Information

#### 1.3.1.2.1 Gantry on Shipping Dolly

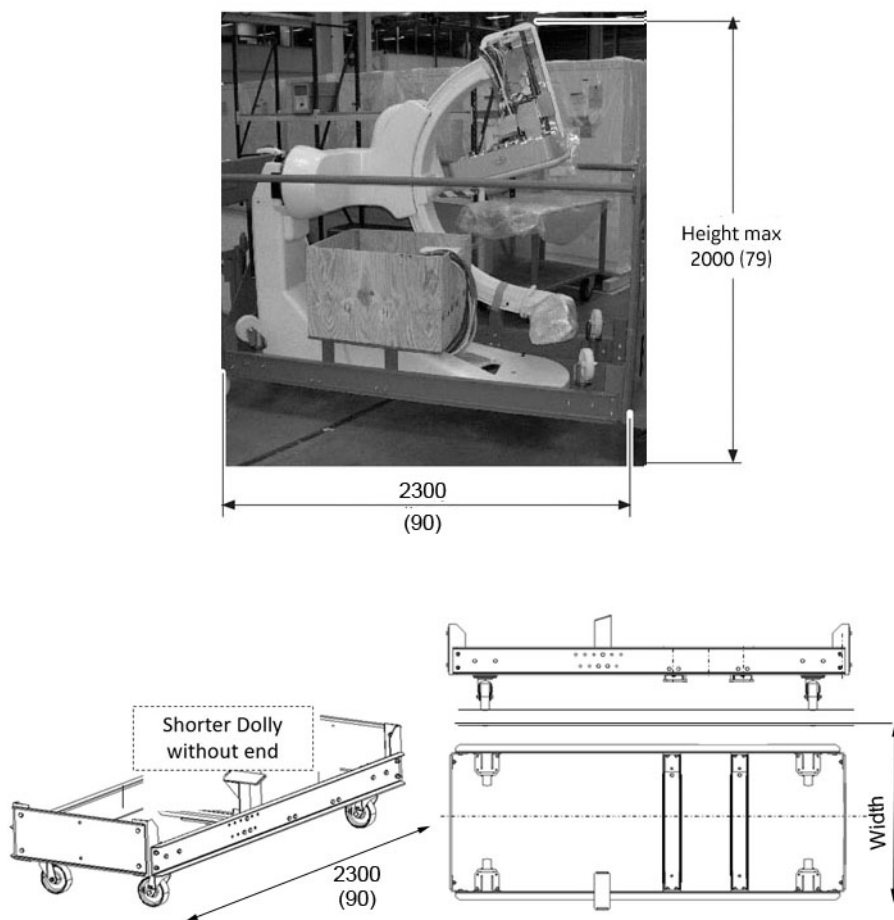
Figure 2 Gantry on Shipping Dolly - Delivered configuration



All dimensions are in mm (in inches)

If the shipping dolly depth is too large you may need to remove the two lift ends and the right and left top handles.

**Figure 3 Gantry on Shipping Dolly - On-site shortened configuration**



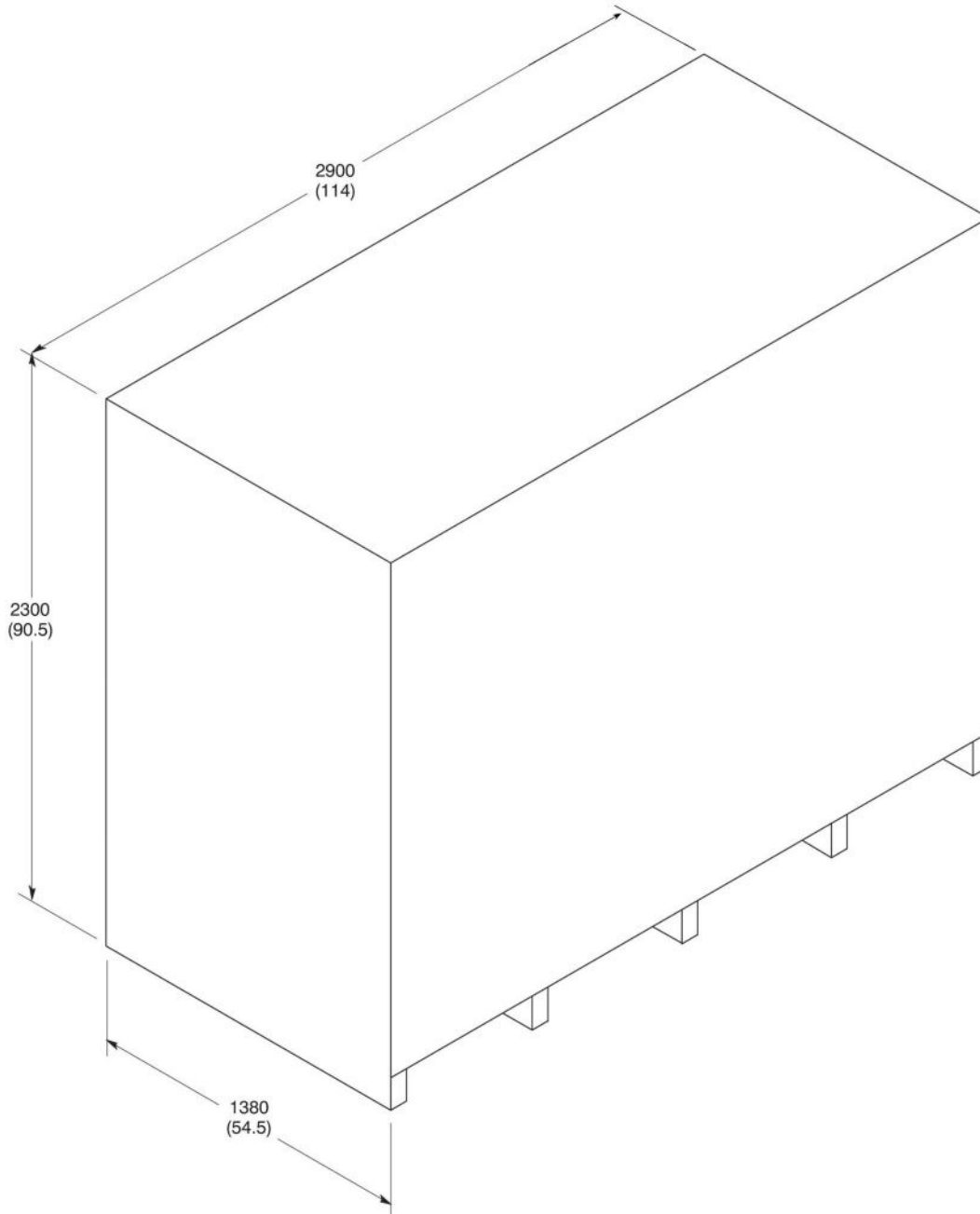
Dimensions in mm (in)

**Table 2 Gantry on Shipping Dolly - On-site shortened configuration**

Max width with Gantry mm (in)	Length mm (in)	Height mm (in)
1160 (46)	2300 (90)	2000 (79)

### 1.3.1.2.2 Gantry Air Shipment

Figure 4 Gantry Air Shipment



DIMENSIONS IN MM (INCHES)

NOT TO SCALE

### 1.3.1.2.3 C-FRT Cabinet Shipment

Figure 5 C-FRT Cabinet Shipment



Dimensions in mm (in)

**NOTE**

Pallet is delivered as part of C-FRT Cabinet packaging.

### 1.3.1.2.4 NPA PDU Shipment

Figure 6 NPA PDU Shipment

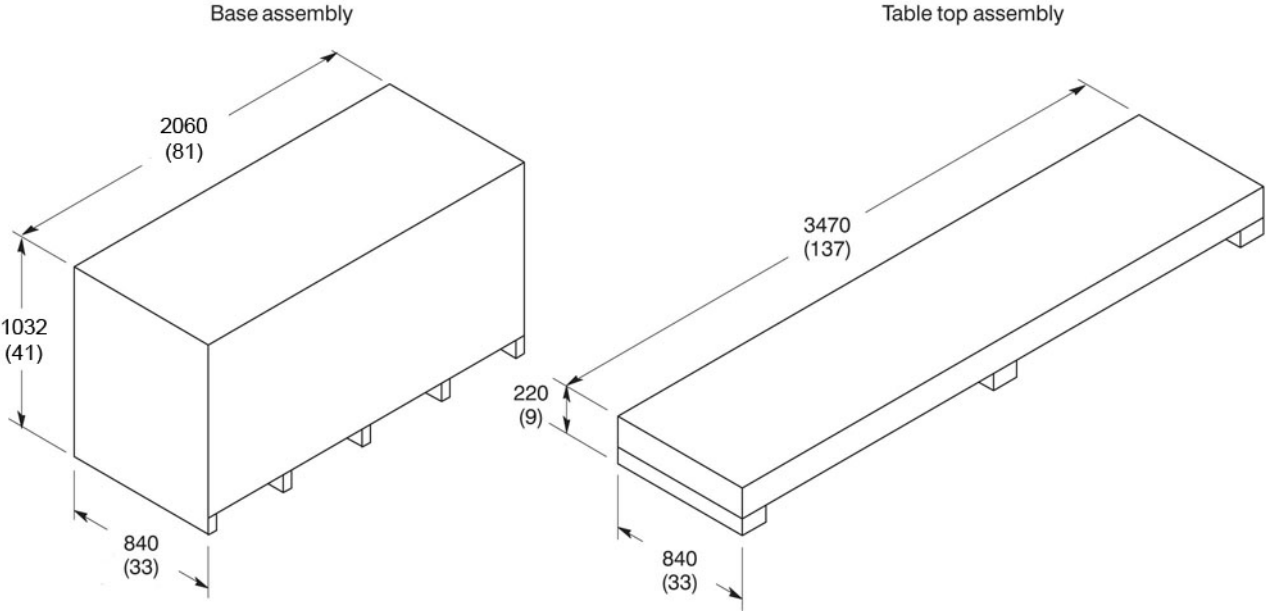


**NOTE**

Pallet is delivered as part of NPA PDU packaging.

### 1.3.1.2.5 Omega Table Shipment

Figure 7 Omega Table Shipment

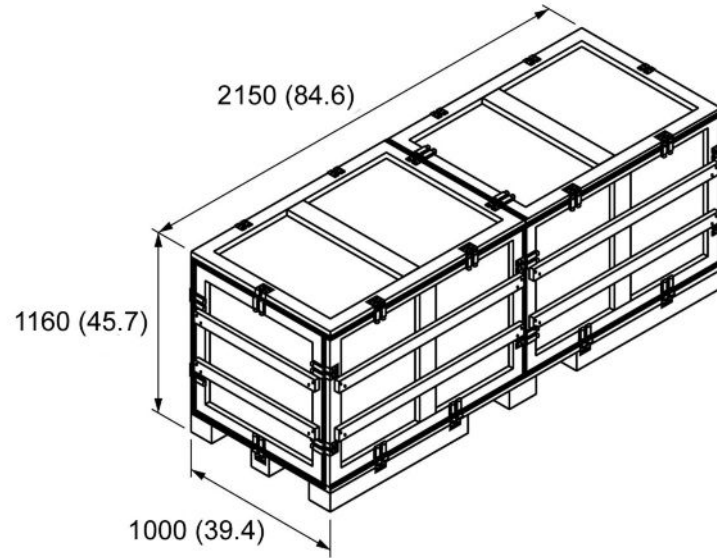


DIMENSIONS IN MM (INCHES)

NOT TO SCALE

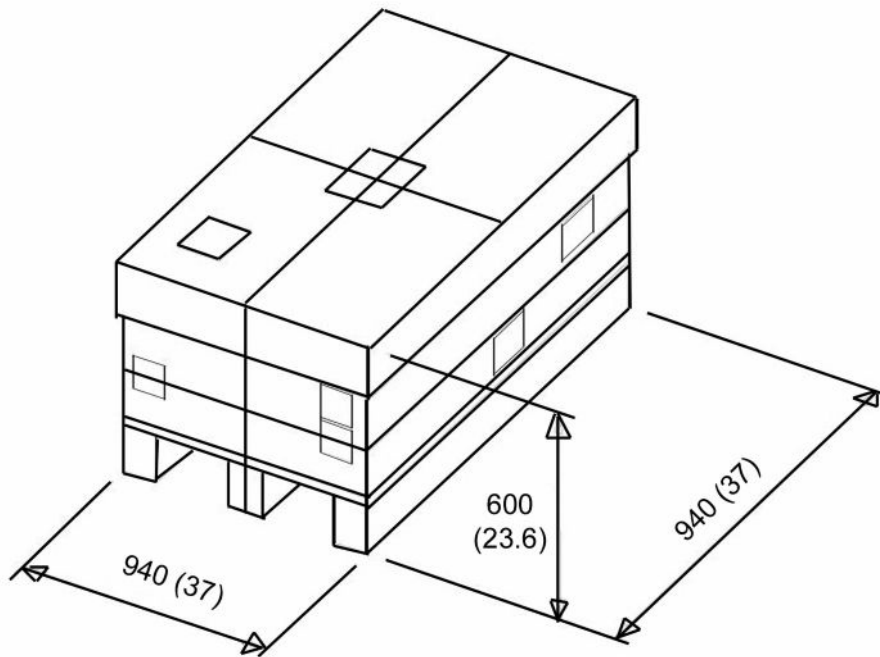
### 1.3.1.2.6 Innova<sup>IQ</sup> Table Shipment

Figure 8 Innova<sup>IQ</sup> Table Shipment



All dimensions are in mm (inches)

**Figure 9 Covers Shipment**

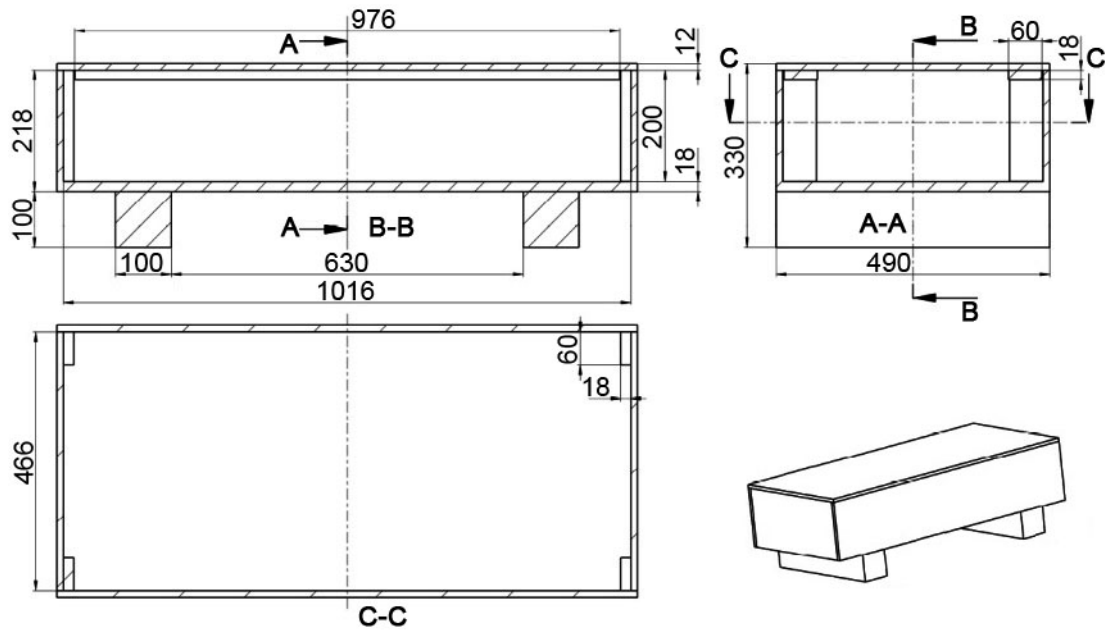


All dimensions are in mm (inches)

### **1.3.1.2.7 Monitor suspension with fixed point dual arm**

### 1.3.1.2.7.1 Substructure for Dual Arm suspension

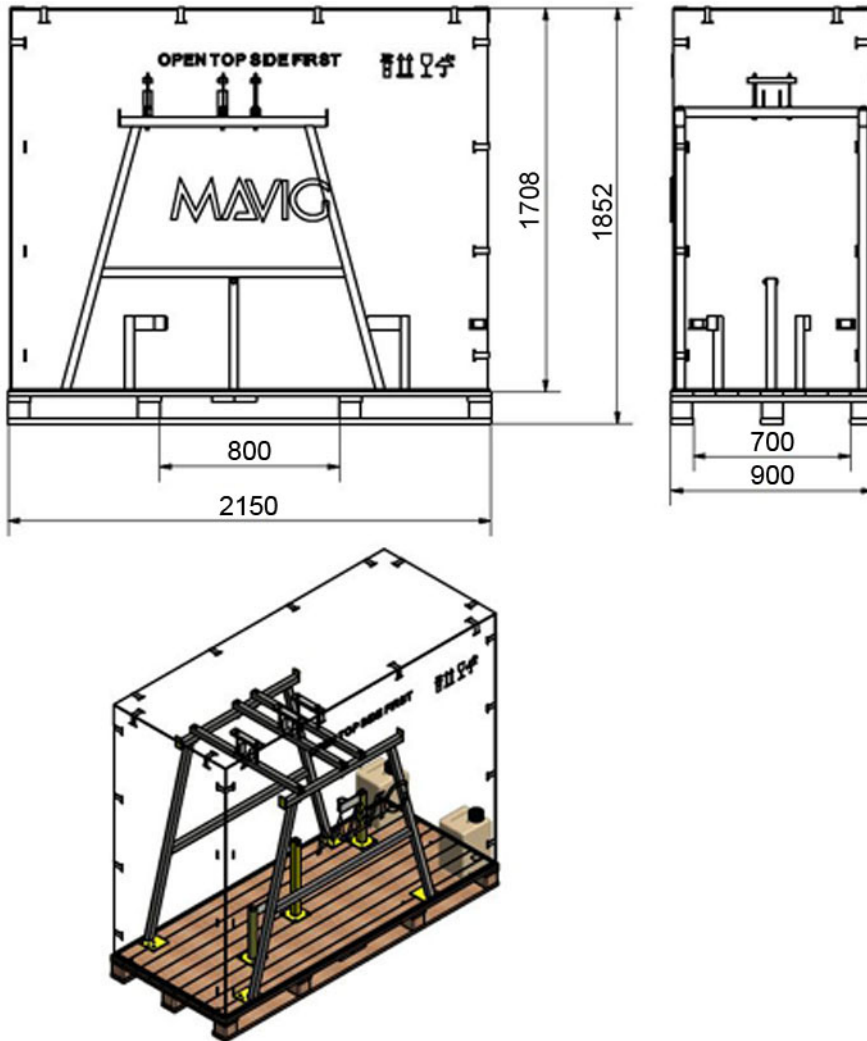
Figure 10 Shipment of Substructure for Dual Arm suspension



Dimensions in mm

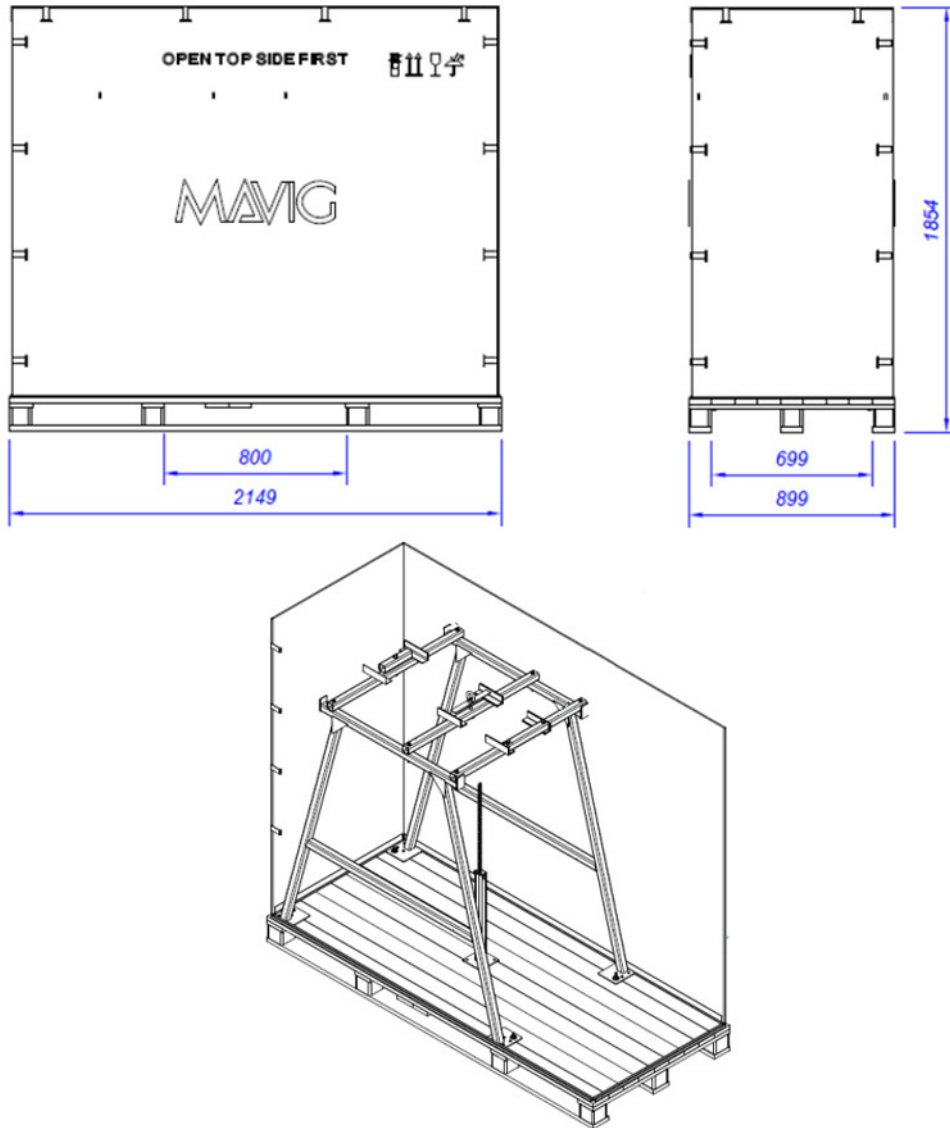
### 1.3.1.2.7.2 MAVIG suspension with fixed point dual arm for 4 19" Monitors

Figure 11 MAVIG suspension with fixed point dual arm for 4 19" monitors Shipment



### 1.3.1.2.7.3 Mavig suspension with fixed point dual arm for Large Display Monitor

Figure 12 Large display MAVIG suspension with fixed point dual arm Shipment



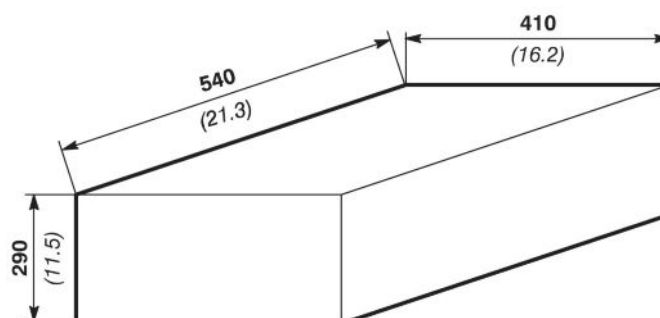
Dimensions in mm

### 1.3.1.2.8 Other Elements Package

**NOTE**

All OEM parts are shipped inside there original boxes group as needed on pallets.

Figure 13 Other Standard Shipping Box



Dimensions in mm (in)

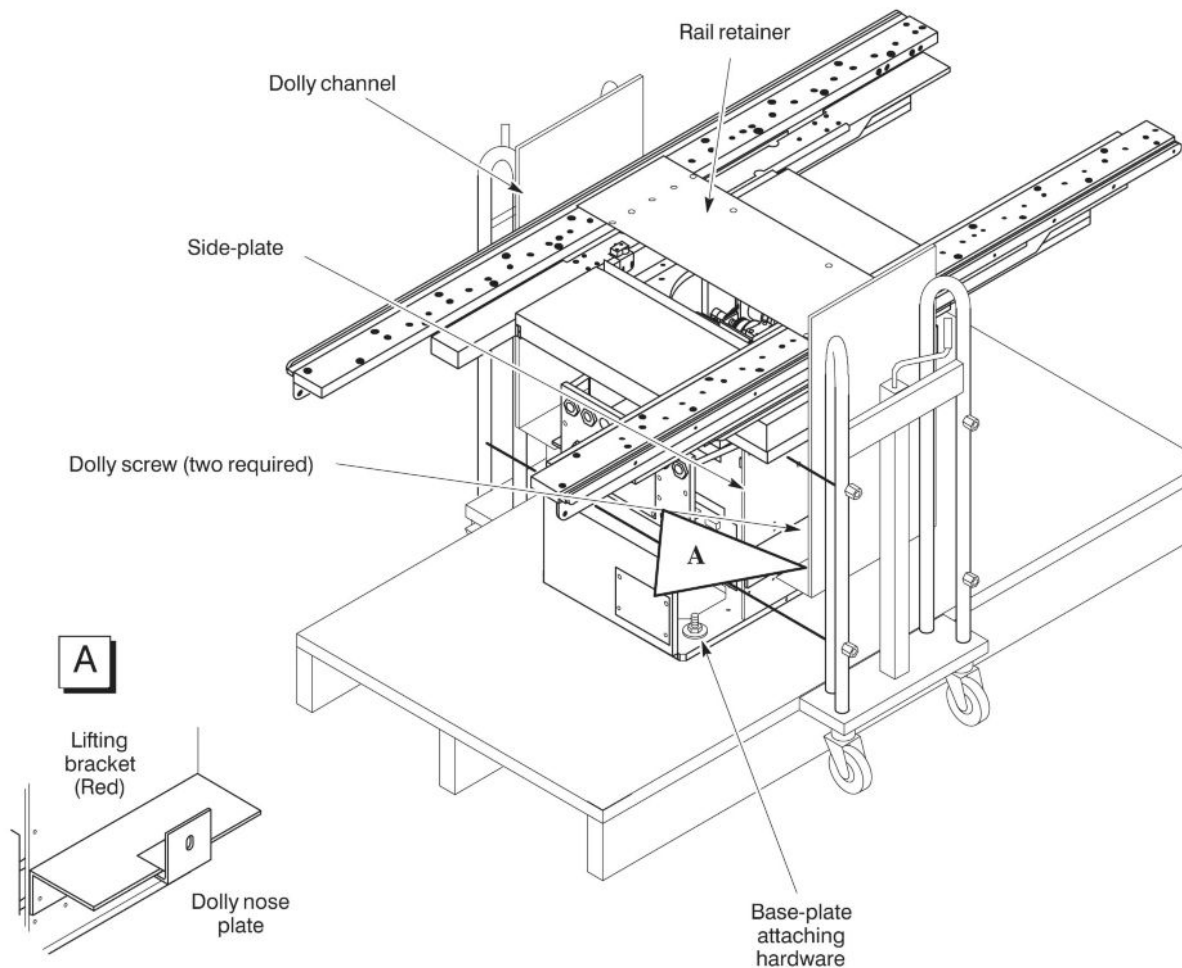
### 1.3.2 Tools and Test Equipment

Refer to [Table 3 on page 19](#). To obtain a list of tools and test equipment for components not specified in [Table 3 on page 19](#), refer to the appropriate component Pre-Installation Manual.

Table 3

PRODUCT OR COMPONENT	TOOL OR TEST EQUIPMENT	USED FOR	SOURCE	RECEIVED (DATE)
All	Service Engineer's Tool Case	General Use		
Innova LC Positioner	Level, Protractor Type	Positioner Checks		
	Torque Wrench 2 to 20 daN.m (15 ft. lbs. to 150 ft. lbs.)	Positioner Checks		
	1/2 inch Ratchet Wrench	Raise and Lower Positioner shipping dolly		
	Laptop Computer	Positioner Configuration and Calibration		
Omega/Innova <sup>IQ</sup> Table	Same as for Innova LC (Service Engineer's Tool Case) Fill in any additional tools or test equipment as required			
	Installation dolly (PN 5265134)	Installation		
Monitor Suspension	Ladders	Installation		
	<b>(For Suspension with rails)</b> XT Lifting Tool (x2) 46-156940G3	Installation		

continued				
PRODUCT OR COMPONENT	TOOL OR TEST EQUIPMENT	USED FOR	SOURCE	RECEIVED (DATE)
	<p><b>(For Suspension with fixed point Dual Arm for 4 19" monitors)</b></p> <ul style="list-style-type: none"> <li>• Installation tool and Pelicase (P/N 5758418)</li> </ul>	Installation		
	<p><b>(For Suspension with fixed point Dual Arm for LDM)</b></p> <ul style="list-style-type: none"> <li>• Installation tool and Pelicase (P/N 5758418)</li> <li>• Torque wrench 200 N.m (150 ft.lbs)</li> </ul>	Installation		

**Figure 14 Omega Table Installation Dolly**

### 1.3.3 Door Size Requirements

Minimum door sizes also apply to hallways and elevators. For additional details, refer to [Shipping Information](#).

#### 1.3.3.1 Door Height

The minimum doors height shall be determined to accommodate for the following components:

- The Innova Gantry on its dolly: **2 m** (79 in).
- The C-FRT Cabinet on its pallet: **2.20 m** (87 in).

If the door height is not sufficient, you may need to put the C-FRT Cabinet on its wheels (refer to Dimension Drawings [Figure 50 on page 73](#) and to *IST0527 - C-FRT Cabinet Installation* in the Service Manual).



Adhere to the limit of use described in the Installation Job card.

### 1.3.3.2 Door Width

The minimum door width needed (to accommodate the Innova LC shipping dolly) is **1.23 m** (48.4 in) in delivery configuration or **1.16 m** (46 in) in on-site shortened configuration.

#### NOTE

Door widths are based on a straight-in approach requiring a 2.44 m (96 in) wide corridor. Calculations need to be made for accommodation of equipment through narrower corridors.

### 1.3.3.3 Elevator Depth

The minimum elevator depth needed to accommodate the Innova Gantry shipping dolly is:

- **2.82 m** (111 in) with the Innova Gantry shipping dolly in delivery configuration.
- **2.30 m** (90 in) with the Innova Gantry shipping dolly in shortened configuration.

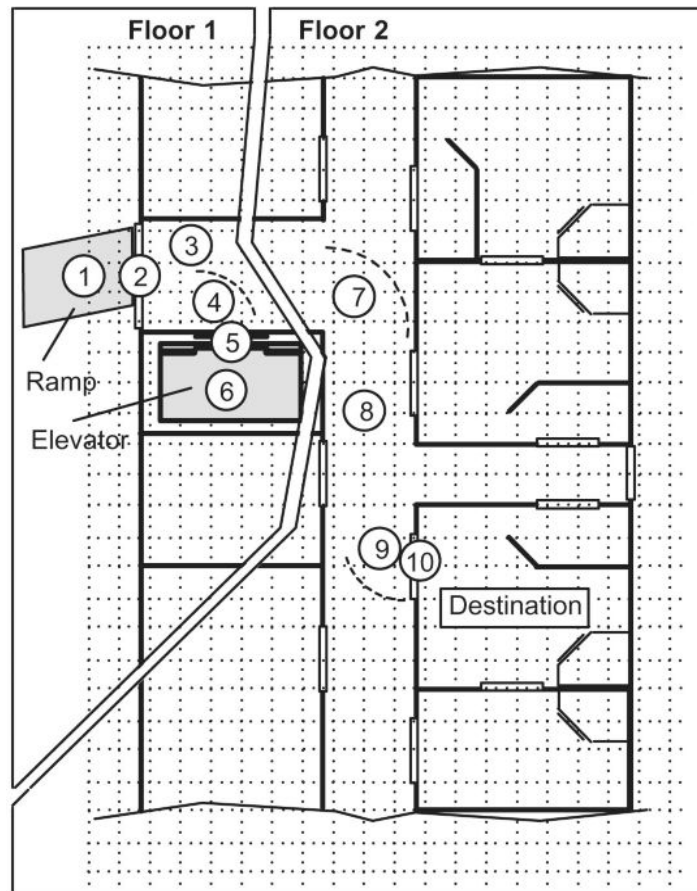
## 1.3.4 Route Survey

### 1.3.4.1 Step One – Sketch

Start preparing Route Survey by sketching a floor plan of the hospital or clinic which will receive the equipment. Include all areas on the delivery route from outside the building to destination. See [Figure 15 on page 23](#).

Reference Numbers: Numbers in circles refer to Route Survey data. The Route Survey is a form on which site data are listed (see [1.3.4.2 Step Two – Survey on page 23](#)).

Figure 15



### 1.3.4.2 Step Two – Survey

Data concerning the intended delivery route are recorded on the Route Survey in the following pages. Record all loading capacities, corridor widths, door openings, turning radii, flooring materials, elevator sizes, obstructions and so on.

### 1.3.4.3 Step Three – Check

Verify equipment can be transported via the route specified in 1.3.4.1 Step One – Sketch on page 22. Compare Route Survey compiled in 1.3.4.2 Step Two – Survey on page 23 to equipment specifications in this and other applicable pre-installation directions.

Table 4

Ref. no.	Area: loading dock, doorway, hallway, turn, elevator, obstruction, etc.	Limitations: loading capacity, height, width, depth flooring material, radius, etc.



## 1.4.2 System Storage

If storing a system prior to installation, the system shall be stored in its original packaging in a temperature and humidity controlled environment protected from water and dust.

**Table 6 Storage Requirement**

Component	TEMPERATURE		HUMIDITY		PRESSURE	
	MIN	MAX	MIN	MAX	MIN	MAX
All components	+10°C (+50°F)	+40°C (+104°F)	10%	80%	700 hPa	1030 hPa

It is recommended that the temperature for storage does not exceed +25°C (+77°F).

Systems with the Fluoro UPS shall be stored for less than 6 weeks if the storage temperature is above 30°C (86°F), and less than 12 weeks if the storage temperature is above +25°C (+77°F).

Systems with the 1 kVA UPS or 8 kVA UPS shall be stored for less than 14 weeks if the storage temperature is above 30°C (86°F), and less than 25 weeks if the storage temperature is above +25°C (+77°F).

The overall storage time for the system shall be less than 6 months.

### Special instructions for the detector:

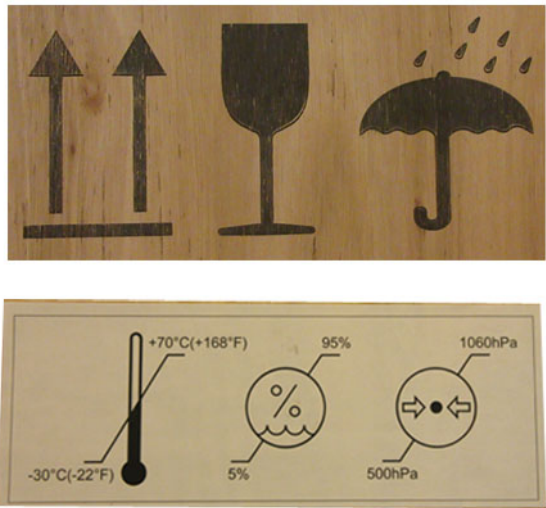
The detector is shipped separately from the system and is very sensitive to temperature and humidity, as irreparable damage to the detector scintillator will occur. As defined in [Table 6 on page 25](#), it shall be stored between +10 and +40°C (+50 to +104°F) and less than 80% RH inside its unopened shipping box, the lowest temperature and humidity being preferable. If it is to be stored outside of its shipping box or if the plastic wrapping has been removed, it should be stored at +20°C (68°F) or less and 30% RH or less.

### 1.4.3 Handling instructions

The packaging of the following components are marked with special handling instructions for transport:

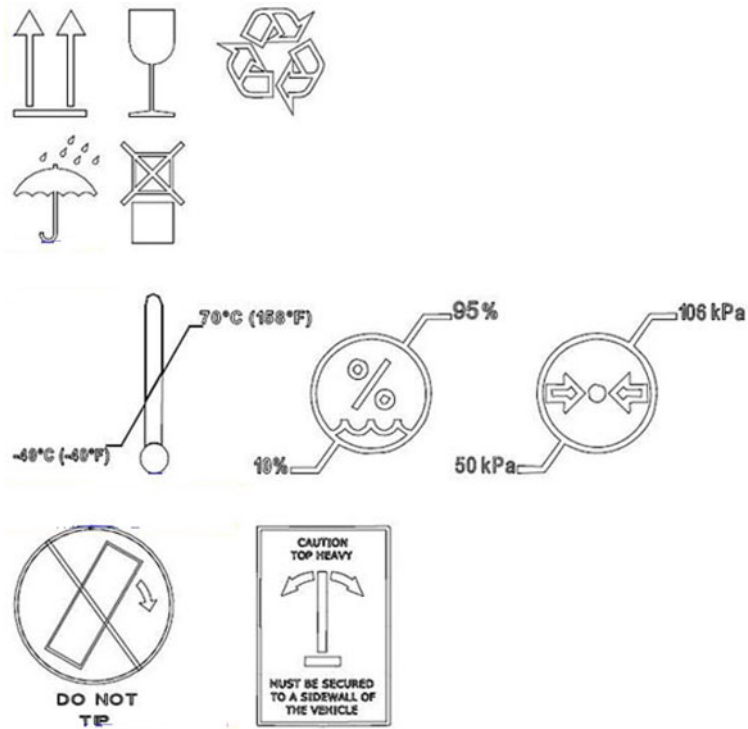
- NPA PDU

**Figure 16 NPA PDU - Labels on packaging**



- C-FRT Cabinet

**Figure 17 C-FRT Cabinet - Labels on packaging**



- Gantry

**Figure 18 Gantry - Label on packaging**



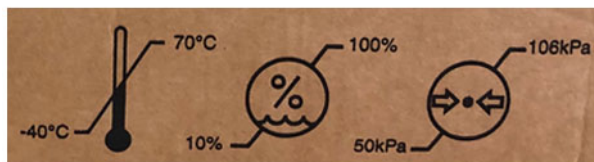
- Patient Table

**Figure 19 Patient Table - Label on packaging**



- Detector

**Figure 20 Detector - Labels on packaging**



Page intentionally left blank

# Chapter 2 Equipment Requirements

## 2.1 System Components

### 2.1.1 Presentation of the 3 Rooms

The components shall be installed in three different rooms with different constraints: the Exam Room, the Control Room and the Technical Room.

#### 2.1.1.1 Exam Room

This is where the patient is situated. It contains the table on which the patient is lying, the table side user interfaces (TSUI), the gantry, the exam monitors, and accessories.

#### 2.1.1.2 Control Room

This room contains user interface and control monitors. No intentional or unintentional contact with the patient shall occur with the patient in this area.

#### 2.1.1.3 Technical Room

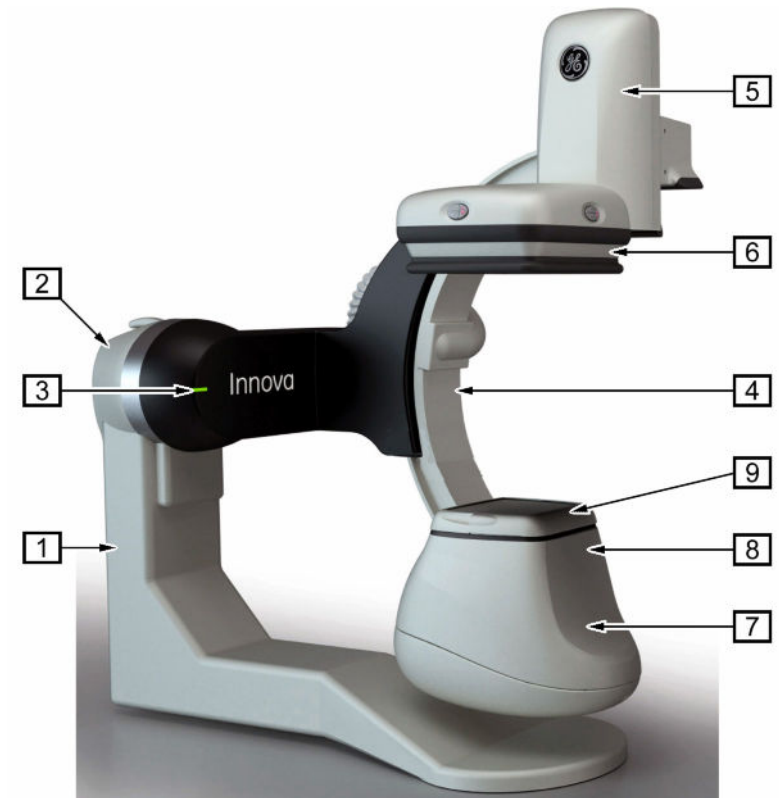
This room contains all electronic cabinets. No intentional or unintentional contact with the patient shall occur with the patient in this area. This room shall be separated from the Exam Room and the Control Room, in order to minimize risks of transmission of airborne pathogens. Its construction should be adapted to minimize ambient noise level; for example the use of glass doors instead of louvered hung doors.

## 2.1.2 Description of the System

### 2.1.2.1 Core system

#### 2.1.2.1.1 Gantry

Figure 21 Gantry



1. L-arm
2. Pivot
3. X-Ray LED
4. C-Arc
5. Motorized Elevator for the Detector
6. Detector 21 cm, 31 cm or 41 cm
7. X-Ray Tube
8. Collimator
9. X-Ray Tube cover spacer

### 2.1.2.1.2 Patient Table

Patient Table depends on your System.

**Table 7 Compatibility matrix for Patient Table**

	Innova IGS 520	Innova IGS 530	Innova IGS 540
OMEGA IV Compact Table	Yes	No	No
OMEGA V long Table	Yes	Yes	Yes
Innova <sup>IQ</sup> Table	Yes	Yes	Yes

**Figure 22 Omega Table (with TSSC)**



**Figure 23 Innova<sup>IQ</sup> Table**



### 2.1.2.1.3 User Interfaces

Figure 24 User Interfaces



Item	Description
[1]	Smart Handle
[2]	Smart Box
[3]	Table Side Status Control (TSSC)
[4]	Table Panning Device (TPD)
[5]	Intelligent Touchscreen Unit (ITU)

(continued)	
Item	Description
[6]	Table Footswitch
[7] or [8]	Remote Box for Omega table or Remote Box for Innova <sup>IQ</sup> table and Inova <sup>IQ</sup> OR table

### 2.1.2.1.4 Accessories for Innova<sup>IQ</sup> Table

Figure 25



Item	Description
[1]	Anesthetic Screen Holder
[2]	Round Post clamp

(continued)	
Item	Description
[3]	Sleeve
[4]	Arm Board

**Figure 26**



Item	Description
[1]	Cart
[2]	Head Widener
[3]	Universal Clamp
[4]	Width Extender

(continued)	
Item	Description
[5]	Patient Restraint Strap
[6]	Rail Extender
[7]	TSUI Adaptor Rail

### 2.1.2.1.5 Monitors

By default:

- Two 19" monitors are provided in the Exam Room:
  - LIVE monitor,
  - REVIEW monitor.
- Two 19" monitors are provided in the Control Room:
  - LIVE monitor,
  - DL monitor.

### 2.1.2.1.6 Electronic Cabinets

The following cabinets are provided with the system:

- C-FRT Cabinet, which contains the high voltage generator, 2 PCs, IT components and the boards for the Gantry and Table control.
- NPA PDU (Power Distribution Unit) / System Interface Cabinet.
- One UPS among:
  - 1 kVA UPS for system safe shutdown,
  - 8 kVA UPS to maintain all functions except X-Ray acquisitions and Omega table movement during power failures,
  - Fluoro UPS (2 different models for UL and CE markets): to complete an exam in fluoroscopy mode during power failures.
- Tube Chiller / Tube Conditioner.
- Detector Conditioner.

### 2.1.2.2 Options

#### 2.1.2.2.1 Large Display Monitor (LDM)

The system can integrate a Large Display solution to:

- see images larger at full IQ with greater flexibility in monitor distance in the procedure room.

- display multiple video images simultaneously at different sizes based on stage of workflow.
- conveniently switch operator defined video layouts at different points in procedure workflow.

This option consists in a 55" color monitor and 2 backup 19" monitors in the Exam Room. A second optional large Display monitor can be provided.

### 2.1.2.2.2 V-Point

The V-Point option is available only for the systems equipped with the Large Display Option.

The V-Point is a fixed video input for a third party device, located in the Exam Room or in the Control Room. It allows to display the image of this third party device on the LDM. Up to three V-Point can be installed.

The V-Point is compatible with DVI-D (digital only). The maximum supported resolution is 1920 x 1200 60 Hz.

The V-Point **[1]** is provided with a box **[2]** that allows the installation on walls. It is mandatory to install the V-Point with its box. When installed in the Exam Room, the V-Point shall not be installed under the table.

**Figure 27 V-Point Option**



The maximum distance between the V-Point and the C-FRT cabinet is 36 m. The diameter of the cable is 20 mm. The routing of the cable shall respect a minimum bending radius of 30 mm.

### 2.1.2.2.3 User Interfaces

The user interfaces available on option are:

- In-room AW mouse interface kit [1].

**NOTE**

The dongle and the mouse are not provided in the kit.

- Bolus Handle [2].

**Figure 28 Optional User Interfaces**



1



2

### 2.1.2.2.4 Monitors

According to the subscribed options, up to 9 optional monitors can be installed:

- 1 additional 19" monitor in the Exam Room (Roadmap),
- up to 2 additional 19" monitors in the Control Room (Review and Roadmap),
- up to 6 additional 19" monitors in the Exam Room or in the Control Room.

**Table 8 Location of 19" monitors (mandatory and optional) - Without LDM**

Video Splitter Output	Output 1	Output 2	Output 3	Output 4
Live	<b>Exam Room</b>	<b>Control Room</b>	Exam Room or Control Room	Exam Room or Control Room
Review	<b>Exam Room</b>	Control Room	Exam Room or Control Room	Exam Room or Control Room
Roadmap	Exam Room	Control Room	Exam Room or Control Room	Exam Room or Control Room

**Table 9 Location of 19" monitors (mandatory and optional) - With LDM**

Video Splitter Output	Output 1	Output 2	Output 3	Output 4
Live	<b>Exam Room</b>	<b>Control Room</b>	Exam Room or Control Room	LDM
Review	<b>Exam Room</b>	Control Room	Exam Room or Control Room	LDM
Roadmap	Exam Room	Control Room	Exam Room or Control Room	LDM

#### NOTE

Text in **bold** for mandatory 19" monitors.

## 2.1.2.2.5 Monitor Suspensions

GE provides as option several types of suspensions; alternatively, the customer can install the suspension of his choice (third party monitor suspension), provided all requirements in the paragraph [Third Party monitor suspension according to GEHC specifications on page 38](#) are met.

### 2.1.2.2.5.1 19" monitors suspension (without LDM)

The system can be equipped with a suspension for 4 or 6 19" monitors.

Two types of suspension can be provided:

- suspension with rails: an XT inboard monitor bridge. A monitor frame support receiving 4 or 6 19" monitors (fixed monitor suspension).
- suspension with fixed point Dual Arm: available only for suspension with 4 19" MAVIG monitors.

These suspensions are delivered and installed by GE.

### 2.1.2.2.5.2 LDM suspension

For the systems with the LDM option, a specific suspension can be provided:

- a suspension with rails
- a suspension with fixed point dual arm.

These suspensions are delivered and installed by GE.

The two backup monitors are mounted on the back of this suspension for faster access in case of failure.

### 2.1.2.2.5.3 Third Party monitor suspension according to GEHC specifications

The IGS systems can be provided with one or several kits to interface third-party suspensions in addition or in replacement of the standard Mavig Suspension usually provided with the system. These kits provide the power and signal connections for the 19" monitors and the Large Display (LD) monitors (8 Megapixels), and for the infra-red receiver and optional dose display.



**The association of the Innova IGS system or the purchaser's suspension(s) is not covered by the GEHC product certification.**

**The overhead monitor suspension shall be installed by strictly following the GEHC installation instructions. GE specifically disclaims any and all liability arising out of or relating to the use or performance of the monitor suspension (including cables), including, without limitation, any liability or claims relating to patient injury, death, or the reliability of such monitors suspension.**

**The mechanical installation of the third-party suspension and the electrical installation of the third-party monitors are fully under the customer and the installer responsibility. They shall ensure that the third-party suspension and its cables are installed prior to the GE equipment (gantry, table, cabinet) so that the standard GE Service Process can be followed during the system installation. Monitors installation and connections to the GE equipment shall only be made in presence of a GE service representative.**

**The electrical installation of the third-party monitors is fully under customer and installer responsibility.**

**The installer is responsible for ensuring that all requirements from this document are met.**

It is recommended that the vendor contacts GE Service representative and reviews the site planning details before the suspension is installed. The position of each suspension in the exam room shall be planned following the recommendations from the chapter Room Layout, in order to reduce the risk of collision between any fixed part of the suspension and the gantry or table.

In addition, the location of each suspension in the exam room shall be compatible with the maximum cable length defined in the tables after.

#### **NOTE**

GE will not be responsible for any delay in installation if the suspension is not mounted and its cables routed before GE parts arrive on site.

The customer is responsible for providing and replacing any parts of the Third-party Suspension and of the third-party monitors.

Installation requirements:

- The live and roadmap 19" monitors are mandatory in the exam room.
- In order to maintain the IQ performance of the system, only the video cables provided in the kit shall be used to display images on the monitors provided with the system. No extension or additional restpoint is allowed.
- The CAT video cables for the 19" monitors shall respect a minimum bending radius of 24 mm whatever the position of the suspension.
- The CAT video cables for the LDM shall respect a minimum bending radius of 35 mm whatever the position of the suspension.
- Third-party monitors from external sources can be installed on these suspensions but shall not be powered by the system. Only the monitors displaying the images of the system and the AW monitor can be powered by the system.

It is the customer responsibility to ensure that the following requirements are met.

- Each suspension shall not be electrically motorized for up/down motion.

- Each suspension shall comply with the IEC 60601-1 standard and the applicable standards enforced in the country of installation (e.g. when installed in a European Community country, the suspension(s) shall be CE marked). In addition, for North America each suspension shall comply with UL/Canada deviations.
- Each suspension shall be manually adjustable in height and the force to be applied to lift the suspension when fully equipped shall not exceed 200 N in static in the vertical axis, in order to mitigate the risk of patient jammed between table and monitor suspension when the table is lifted up.
- Each suspension shall be installed in order to mitigate the risk of suspension fall on patients and the risk of collisions with the gantry, the table or any other suspension.
- The weight of the monitors and other parts attached to the suspension shall be in accordance with the maximum load supported by the suspension. See [Components location and characteristics on page 43](#) for weight and dimensions. For type of fixation:
  - 19" monitors: VESA 100 x 100 mm.
  - Large Display Monitors: VESA 400 x 400 mm.
  - IR Receiver module and Diamentor Display module: VELCRO.
- Each suspension shall be attached to the ceiling in accordance to the manufacturer's instructions. It shall withstand the maximum suspension load with safety factors in accordance to applicable standards (at least four).
- Each suspension shall be compatible with the chapter Environmental Requirements.
- When the system is installed in an operating room (OR configuration), each suspension shall be compatible with OR environmental constraints.



**NOTICE**

IT IS MANDATORY TO EXECUTE THE GROUNDING CONTINUITY AND THE LEAKAGE CURRENT MEASUREMENTS AS DEFINED IN CHAPTER 5 AND 6 OF *THIRD-PARTY MONITOR SUSPENSION SERVICE INSTRUCTION FOR INSTALLATION*.

The kits to interface a third-party suspension contain the following cables:

**Table 10 Kit for the 19" monitors suspension: all cable length 36 m (34.5 m usable length)**

From	To	Cable
PDU	Suspension	1 power cable for the monitors powered by the system (the power distribution to each monitor shall be provided by the customer)
PDU	Suspension	1 Protective Earth cables for the suspension (the Protective Earth distribution to each monitor shall be provided by the customer)
C-FRT Cabinet	Monitors	6 RJ45 video cables for the 19" monitors of the system or the AW workstation
C-FRT Cabinet	Infrared receiver	1 cable with D-Sub 9 connector

Kit for the 19" monitors suspension: all cable length 36 m (34.5 m usable length) continued		
From	To	Cable
Dose monitor control device	Optional dose displays	2 cables for 2 optional dose displays
3rd party video source	Monitors	2 VGA cables

**Table 11 Kit for the LDM suspension: all cable length 36 m (34.5 m usable length)**

From	To	Cable
PDU	monitors	3 power cables for the LDM and the 2 backup monitors
PDU	monitors	3 separate Protective Earth cables for the LDM and the 2 backup monitors
PDU	Suspension	1 Protective Earth cables for the suspension
C-FRT	Monitors	4 RJ45 video cables for the LDM 1 RJ 45 video cables for each of the backup monitors
C-FRT Cabinet	Infrared receiver	1 cable with D-Sub 9 connector
Dose monitor control device	Optional dose displays	2 cables for 2 optional dose displays

**Table 12 Kit for the additional LDM suspension: all cable length 36 m (34.5 m usable length)**

From	To	Cable
PDU	monitor	1 power cable
PDU	monitor	1 separate Protective Earth cable
C-FRT Cabinet	Monitor	4 RJ45 video cables

**Table 13 Kit for 1 additional in-room 19" monitor: all cable length 24 m (22.5 m usable length)**

From	To	Cable
PDU	Monitor	1 power cable
PDU	Monitor	1 separate Protective Earth cable
C-FRT Cabinet	Monitor	1 RJ45 video cable

### 2.1.2.2.6 Advantage Windows workstation (AW)

The AW workstation option is composed of a workstation, 1 or 2 19" flat panel monitors in the Control Room.

Two optional 19" flat panel monitors can be fixed on the Exam Room suspension, or both AW screens can be displayed on the LDM if the option is present.

### 2.1.2.2.7 CENTRICITY CA1000

Refer to :Centricity Cardiology CA 1000 V2.0 Preinstallation Guide in the OEMs of the Innova IGS 5 Service Manual.

### 2.1.2.2.8 MacLab

Refer to: Direction 2097992-007, Mac-Lab/CardioLab/Centricity Cardiology INW Pre-Installation Manual V6.9.6.

### 2.1.2.2.9 Injectors

The injectors certified for use with the system are:

**Table 14**

Certified Injectors	Omega Table	Innova <sup>IQ</sup> Table/Innova <sup>IQ</sup> OR Table
Medrad Mark 7 (table mount version)	Yes	Yes
Medrad Mark 7 (pedestal mount version)	Yes	Yes
Medrad Mark 7 (ceiling mount version)	Yes	Yes
Acist CVI (pedestal version)	Yes	Yes
Acist CVI (table mount version)	Yes	No
Medtron Accutron HP model number 836	Yes	Yes
Medtron Accutron HP model number 832	Yes	Yes
Medtron Accutron HP model number 890	Yes	Yes
Medtron Accutron HP model number 837	Yes	Yes
Medtron Accutron HP-D model number 833	Yes	Yes

**NOTE**

For MEDRAD Mark 7 table mount and ceiling mount, rack connected to C-FRT cabinet is located in technical room.

Table accessory rail load considerations:

Each table rail can withstand a load of 40 kg (88 lbs) at 150 mm (5.9") (60 N.m or 44.25 ft/lbs). Therefore, only a light load not exceeding 5 kg (11 lbs) at 100 mm (0.33 ft) can be mounted on the same table rail as the injector: for example IV pole with its accessories, pressure head, and so on. The front table rail is generally

used for the TSUI, if needed an optional rail can be installed at table foot end of the Omega V table for other options.

The radiation protection and the injector shall never be installed on the same table rail.

### 2.1.2.3 Components location and characteristics

Table 15

PRODUCT OR COMPONENT	Number of components in:			NET WEIGHT kg (lbs)	DIMENSIONS WIDTH x DEPTH x HEIGHT mm (in)	LOAD ON THE FLOOR kg/m <sup>2</sup> (lb/ ft <sup>2</sup> )
	Exam room	Control room	Technical room			
Gantry	1	-	-	(For System with 21 cm detector) 710 (1,565) (For System with 31 cm detector) 762 (1,680) (For System with 41 cm detector) 786 (1,733)	see Figure 29 on page 49, Figure 30 on page 50 and Figure 31 on page 51	2678 (549)
Omega Table	1	-	-	741.6 (1,635) See NOTE (1)	see Figure 32 on page 52 and Figure 35 on page 56	3065 (628)
Innova <sup>IQ</sup> Table		--	-	1017 (2,242) See NOTE (1)	see Figure 38 on page 61	2260 (463)
Footswitch	1	-	-	Not applicable	Not applicable	Not applicable
Smart Box or Smart Handle	1	-	-	6 (13)	Not applicable	Not applicable
TSSC	1	-	-	6 (13)	Not applicable	Not applicable
ITU	1	-	-	3.8 (8)	Not applicable	Not applicable
VCIM	-	1	-	0.95 (2.09)	450 (17.7) x 150 (5.9) x 50 (2)	Not applicable
DL Keypad	-	1	-	1.4 (3)	see Figure 49 on page 72	Not applicable

continued						
PRODUCT OR COMPONENT	Number of components in:			NET WEIGHT kg (lbs)	DIMENSIONS WIDTH x DEPTH x HEIGHT mm (in)	LOAD ON THE FLOOR kg/m2 (lb/ ft2)
	Exam room	Control room	Technical room			
DL Monitor (Eizo S1934 or Eizo MX191)	-	1	-	<b>(For Eizo S1934)</b> 5.6 (12.3) <b>(For Eizo MX191)</b> 8.2 (18)	Not applicable	Not applicable
C-FRT Cabinet	-	-	1	556.2 (1,226)	see <a href="#">Figure 50 on page 73</a>	643 (132)
NPA PDU / System Inter- face cabinet	-	-	1	285 (628)	see <a href="#">Figure 51 on page 74</a>	847 (173)
1 kVA UPS	-	-	1	14.8 (32.6)	see <a href="#">Figure 52 on page 76</a>	Not applicable
8 kVA UPS	-	-		84 (185)	see <a href="#">Figure 53 on page 77</a>	Not applicable
Fluoro UPS UL	-	-		530 (1,169)	see <a href="#">Figure 54 on page 78</a>	975 (200)
Fluoro UPS CE	-	-		480 (1,059)	see <a href="#">Figure 55 on page 79</a>	883 (181)
Tube Chiller / Tube Condi- tioner	-	-	1	120 (265)	see <a href="#">Figure 56 on page 81</a>	424 (87)
Detector Con- ditioner	-	-	1	14.6 (32)	see <a href="#">Figure 57 on page 82</a>	Not applicable
OPTIONS						
Monitors						

continued						
PRODUCT OR COMPONENT	Number of components in:			NET WEIGHT kg (lbs)	DIMENSIONS WIDTH x DEPTH x HEIGHT mm (in)	LOAD ON THE FLOOR kg/m <sup>2</sup> (lb/ ft <sup>2</sup> )
	Exam room	Control room	Technical room			
19" System Monitor (Eizo LX1910 or Eizo RX150) without stand	Up to 6	-	-	(For Eizo LX1910) 4.3 (9.5)  (For Eizo RX150) 5.8 (12.8)	(For Eizo LX1910) 405 (15.9) x 61 (2.4) x 334 (13.1)  (For Eizo RX150) 423 (16.6) x 95 (3.7) x 349 (13.7)	Not applicable
AW Monitor (Barco MVCD-1619 or Eizo MX193)	Up to 2	-	-	(For Barco MVCD-1619) 3.1 (6.8)  (For Eizo MX193) 4 (8.8)	(For Barco MVCD-1619) 411 (16.2) x 67 (2.6) x 348 (13.7)  (For Eizo MX193) 405 (15.9) x 62 (2.4) x 334 (13.1)	Not applicable
19" System Monitor (Eizo LX1910 or Eizo RX150) without stand	-	Up to 3	-	(For Eizo LX1910) 4.3 (9.5)  (For Eizo RX150) 5.8 (12.8)	(For Eizo LX1910) 405 (15.9) x 61 (2.4) x 334 (13.1)  (For Eizo RX150) 423 (16.6) x 95 (3.7) x 349 (13.7)	Not applicable
Large Display Monitor	Up to 2		-	38 (83.8)	1246 (49) x 136 (5.4) x 719 (28.3)	Not applicable
Protective screen for Large Display Monitor	Up to 2		-	12 (26.5)	1251 (49.3) x 55 (2.2) x 725 (28.6)	Not applicable
19" Backup Monitor for Large Display	2	-	-	3.2 (7)	411 (16.2) x 67 (2.6) x 348 (13.7)	Not applicable

continued						
PRODUCT OR COMPONENT	Number of components in:			NET WEIGHT kg (lbs)	DIMENSIONS WIDTH x DEPTH x HEIGHT mm (in)	LOAD ON THE FLOOR kg/m2 (lb/ ft2)
	Exam room	Control room	Technical room			
User Interfaces and accessories						
Additional Smart Box or Smart Handle	1 in Exam room <b>or</b> 1 in Control room		-	6 (13)	Not applicable	Not applicable
Additional TSSC	1 in Exam room <b>or</b> 1 in Control room		-	6 (13)	Not applicable	Not applicable
Bolus Handle	1	-	-	Not applicable	Not applicable	Not applicable
In-room AW mouse interface kit	1		-	Not applicable	Not applicable	Not applicable
Table Side Cart	1	-	-	Not applicable	Not applicable	Not applicable
IR Receiver Module	1	-	-	0.3 (0.7)	112 (4.4) x 31 (1.2) x 76 (3)	Not applicable
Diamantor Display Module	1	-	-	1 (2.2)	210 (8.3) x 146 (5.7) x 58 (2.3)	Not applicable
ECG Acquisition Device Module						
Physio box	1		-	Not applicable	see <a href="#">Figure 58 on page 83</a>	Not applicable
Suspension						
Precabled 19" LCD monitor suspension with rails for 4 monitors	1	-	-	102 (225)	see <a href="#">Figure 59 on page 83</a>	Not applicable
Precabled 19" LCD monitor suspension with rails for 6 monitors	1	-	-	115 (254)	see <a href="#">Figure 60 on page 84</a>	Not applicable

continued						
PRODUCT OR COMPONENT	Number of components in:			NET WEIGHT kg (lbs)	DIMENSIONS WIDTH x DEPTH x HEIGHT mm (in)	LOAD ON THE FLOOR kg/m2 (lb/ ft2)
	Exam room	Control room	Technical room			
MAVIG suspension with fixed point Dual Arm for 4 19" Monitors	1	-	-	66.9 (147.5)	see Figure 65 on page 89 and Figure 66 on page 90	Not applicable
Substructure for Dual Arm suspension (for MAVIG suspension with fixed point Dual Arm for 4 19" Monitors)	1	-	-	58 (128)	see Figure 62 on page 86	Not applicable
Precabled LD suspension with rails (self weight without monitor and accessories given)	1	-	-	215 (474)	see Figure 63 on page 87	Not applicable
Precabled LD Mavig suspension with fixed point dual arm	1	-	-	190 (419)	see Figure 68 on page 92	Not applicable
Substructure for Dual Arm suspension (for LD Mavig suspension with fixed point dual arm)	1	-	-	58 (128)	see Figure 62 on page 86	Not applicable
Utility						
V-Point	3		-	Not applicable	see Figure 70 on page 94	Not applicable

**NOTE**

**(1):** Including patient weight. Patient weight considered is:

- 204 kg (450 lbs) for Omega Table,
- 250 kg (551 lbs) for Innova<sup>IQ</sup> Table.



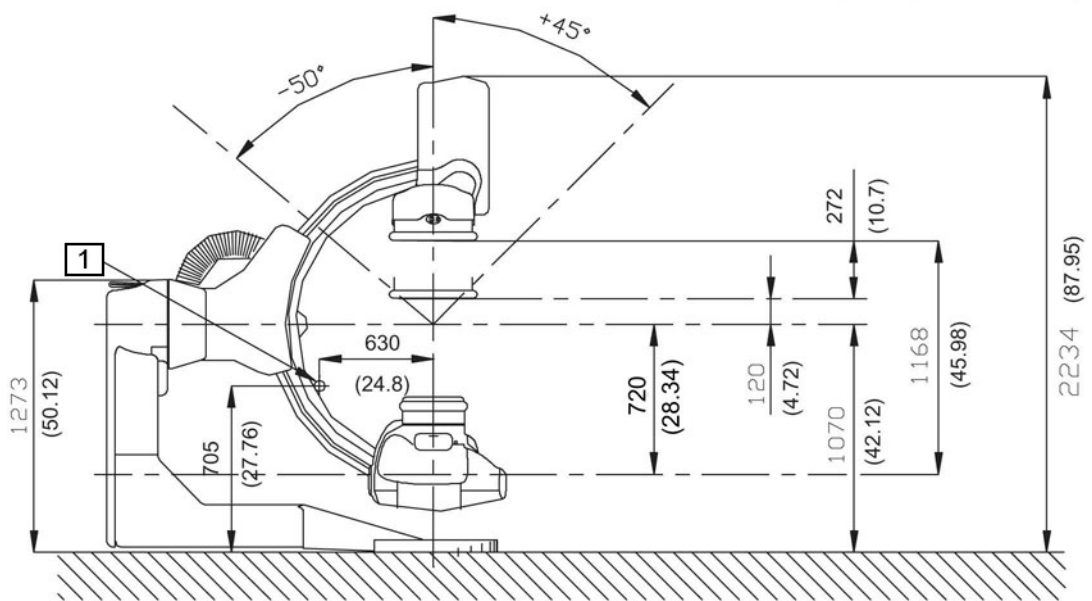
THE COMPONENTS IDENTIFIED AS TO BE INSTALLED IN THE TECHNICAL ROOM ARE NOT CERTIFIED FOR USE OUTSIDE OF THIS AREA. IT IS MANDATORY TO INSTALL THEM IN THE TECHNICAL ROOM.

### 2.1.3 Dimension Drawings

Refer to this section for:

- the dimensional drawings of the system components,
- the location of the components center of gravity,
- Positioner/table relative position drawings.

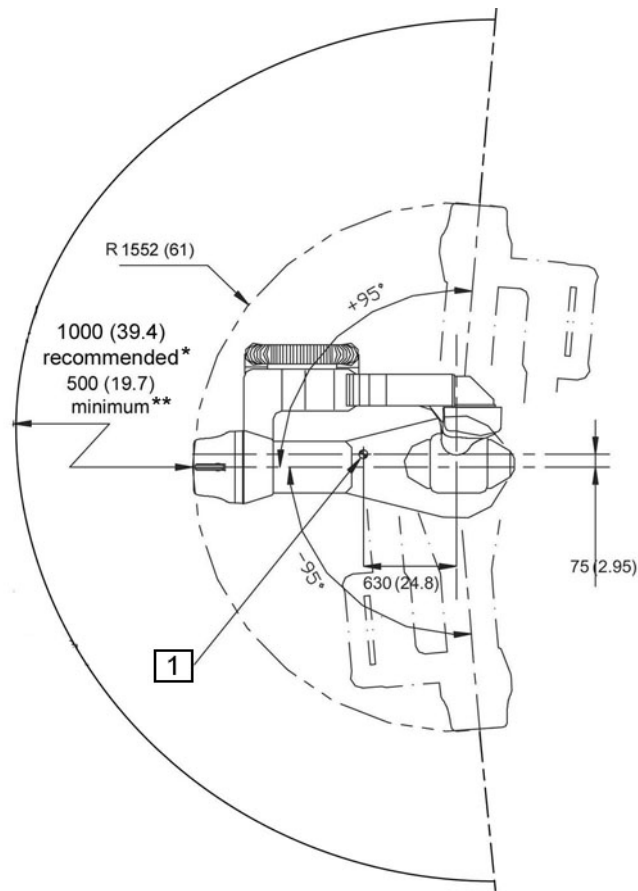
**Figure 29 Gantry - Dimensions and CoG - Side View**



Dimensions in mm (in)

Item	Description
[1]	Center of Gravity

**Figure 30 Gantry - Dimensions and CoG - Top view**



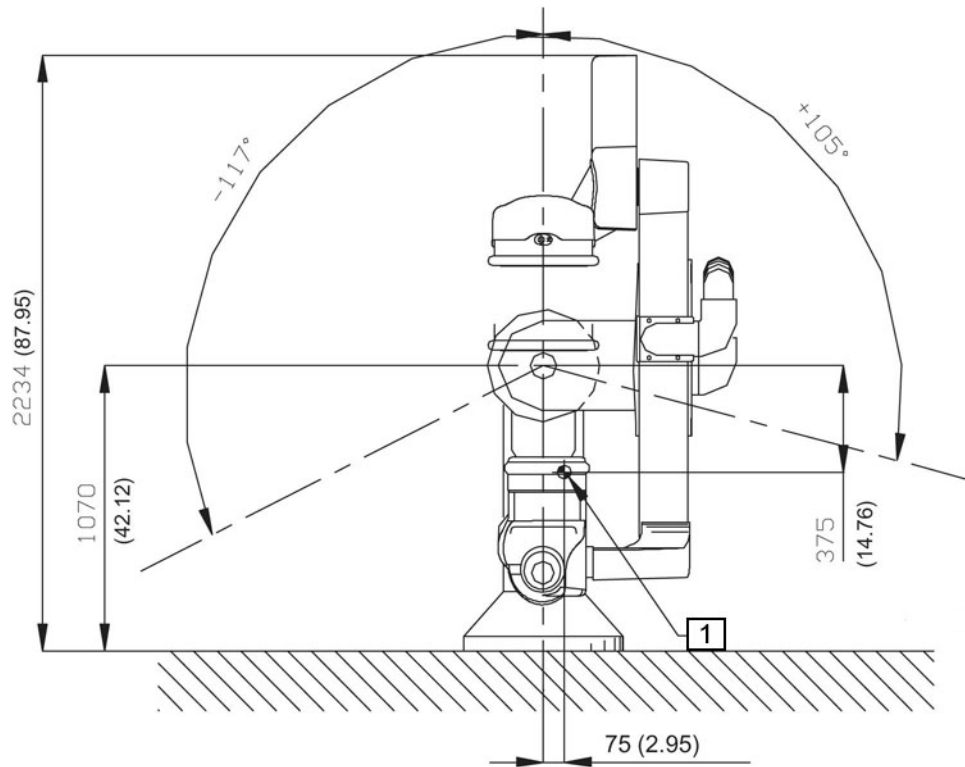
Dimensions in mm (in)

**NOTE**

The LC gantry side movement of +95 to -95 is for motorized movement. With manual movement, a range of +100 to -100 is obtained.

Item	Description
[1]	Center of Gravity
*	Recommended
**	Minimum

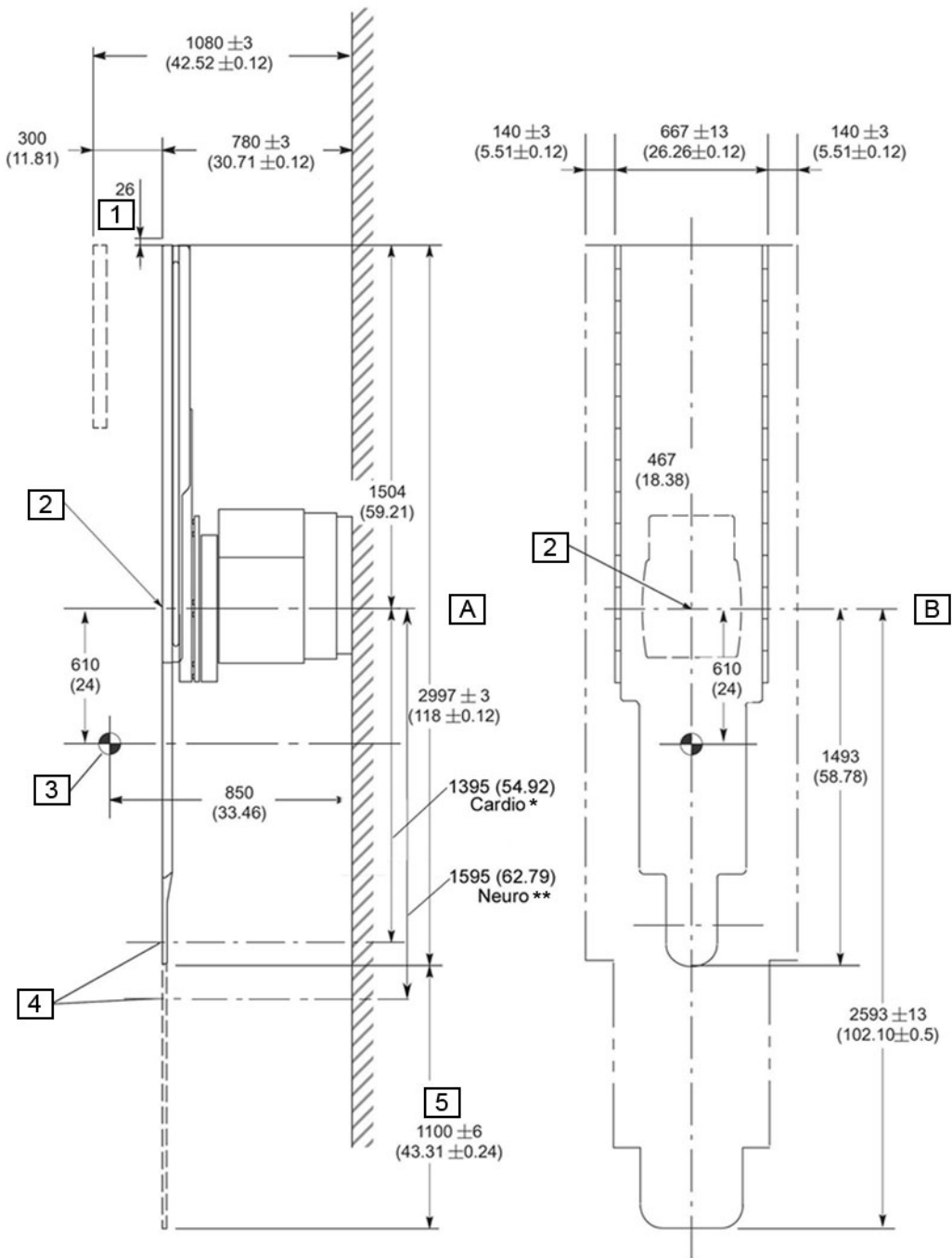
**Figure 31 Gantry - Dimensions and CoG - Front view**



Dimension in mm (in)

Item	Description
[1]	Center of Gravity

**Figure 32 Omega IV Compact Patient Table - Dimensions**

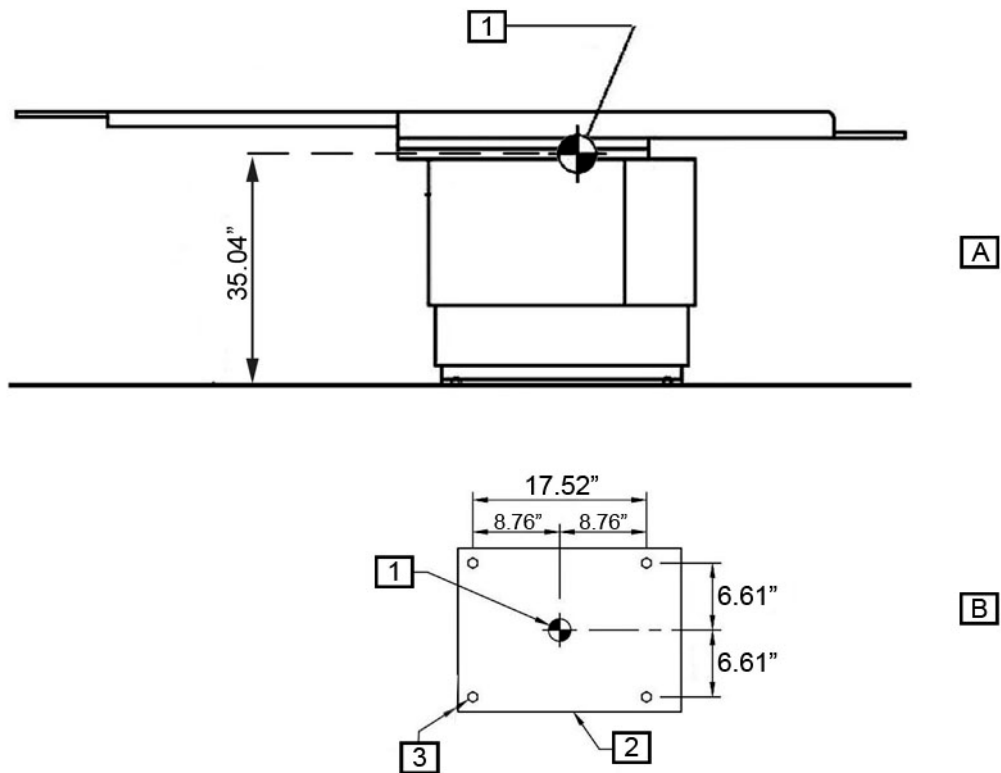


Dimensions in mm (in)

Item	Description
[A]	Side view
[B]	Top view
[1]	Table top at maximum height and patient weight = 204 kg (450 lbs)

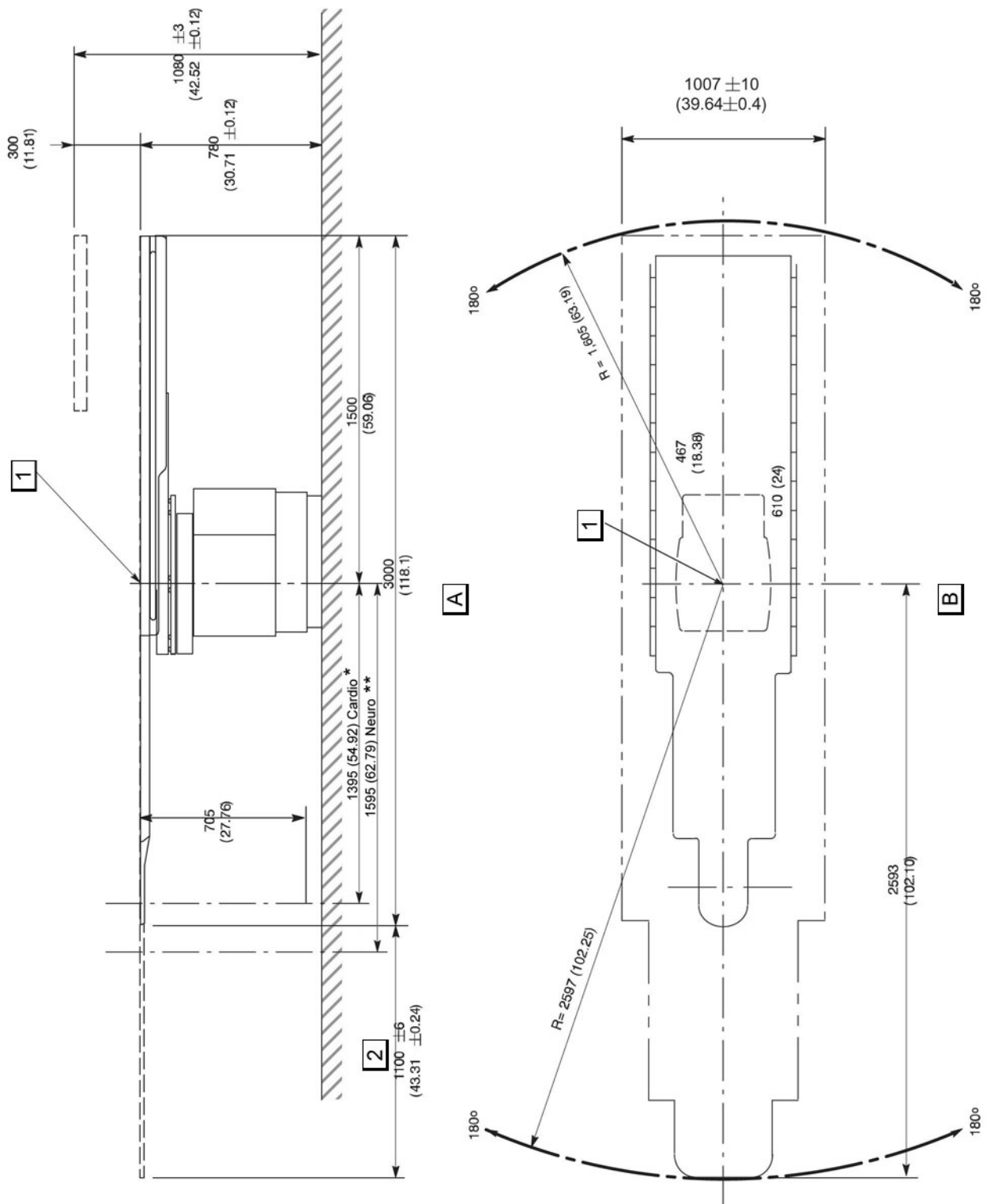
(continued)	
Item	Description
[2]	Omega IV compact patient table pivot point
[3]	Center of Gravity
[4]	LCA H1C positioner isocenter
[5]	Table top travel
*	Cardio
**	Neuro

**Figure 33 Omega IV Compact Patient Table - CoG**



Item	Description
[A]	Side View
[B]	Plan at Base
[1]	Center of Gravity
[2]	Table Base
[3]	Hole diameter: 29 mm (1.14")

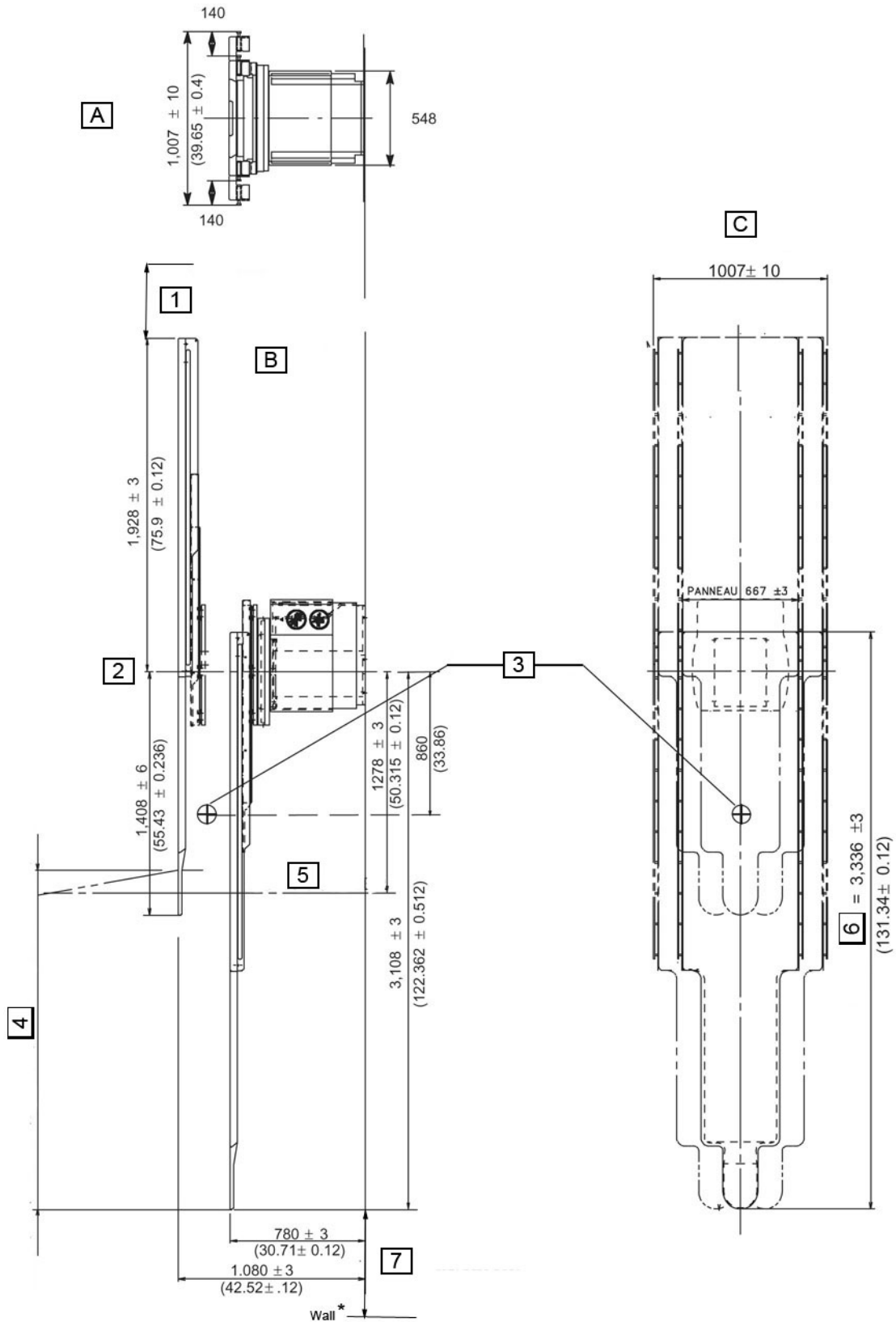
**Figure 34 Omega IV Compact Patient Table Interference Regions (Innova IGS 520)**



Dimensions in mm (in)

Item	Description
[A]	Side view
[B]	Top view
[1]	Omega IV compact patient table pivot point
[2]	Table top travel
*	Cardio
**	Neuro

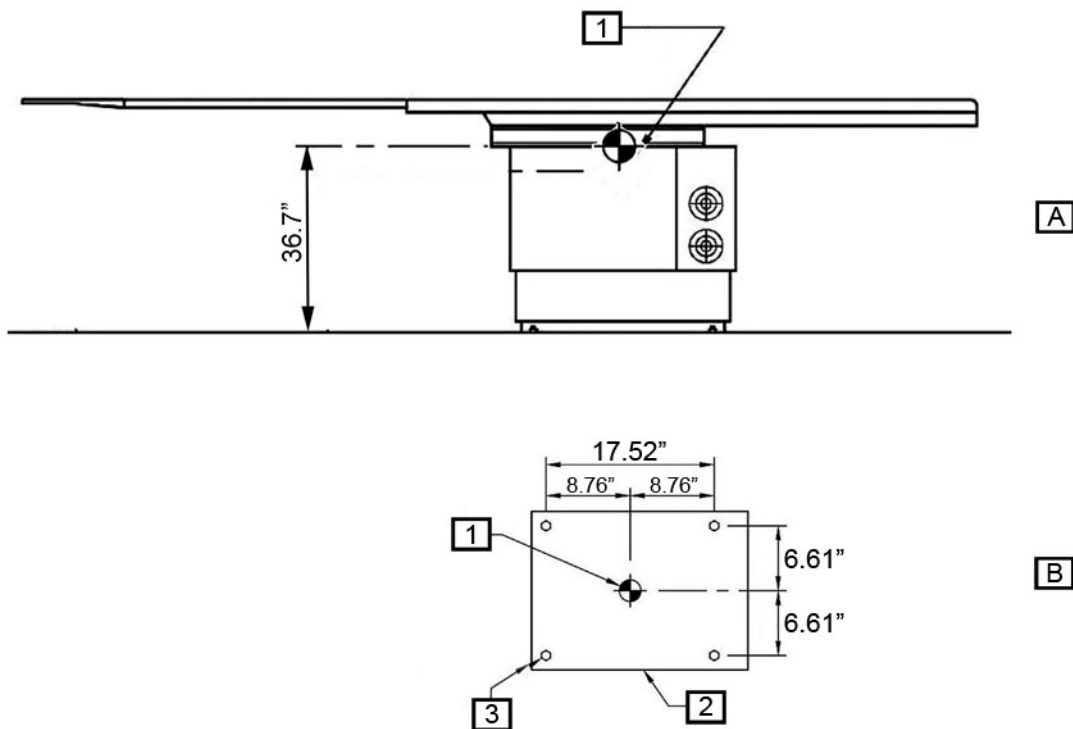
**Figure 35 Omega V Long Patient Table - Dimensions**



Dimensions in mm (in)

Item	Description
[A]	Front view (foot end)
[B]	Side view
[C]	Top view
[1]	500 mm (19.5 in) minimum clearance between table end and nearest object
[2]	Table pivot
[3]	Center of Gravity
[4]	Patient coverage = 1980 (77.95) between mechanical stops
[5]	LCA isocenter
[6]	Table top
[7]	Caution: a distance of 700 mm (27.6 in) is mandatory if the head extender is used
*	Wall

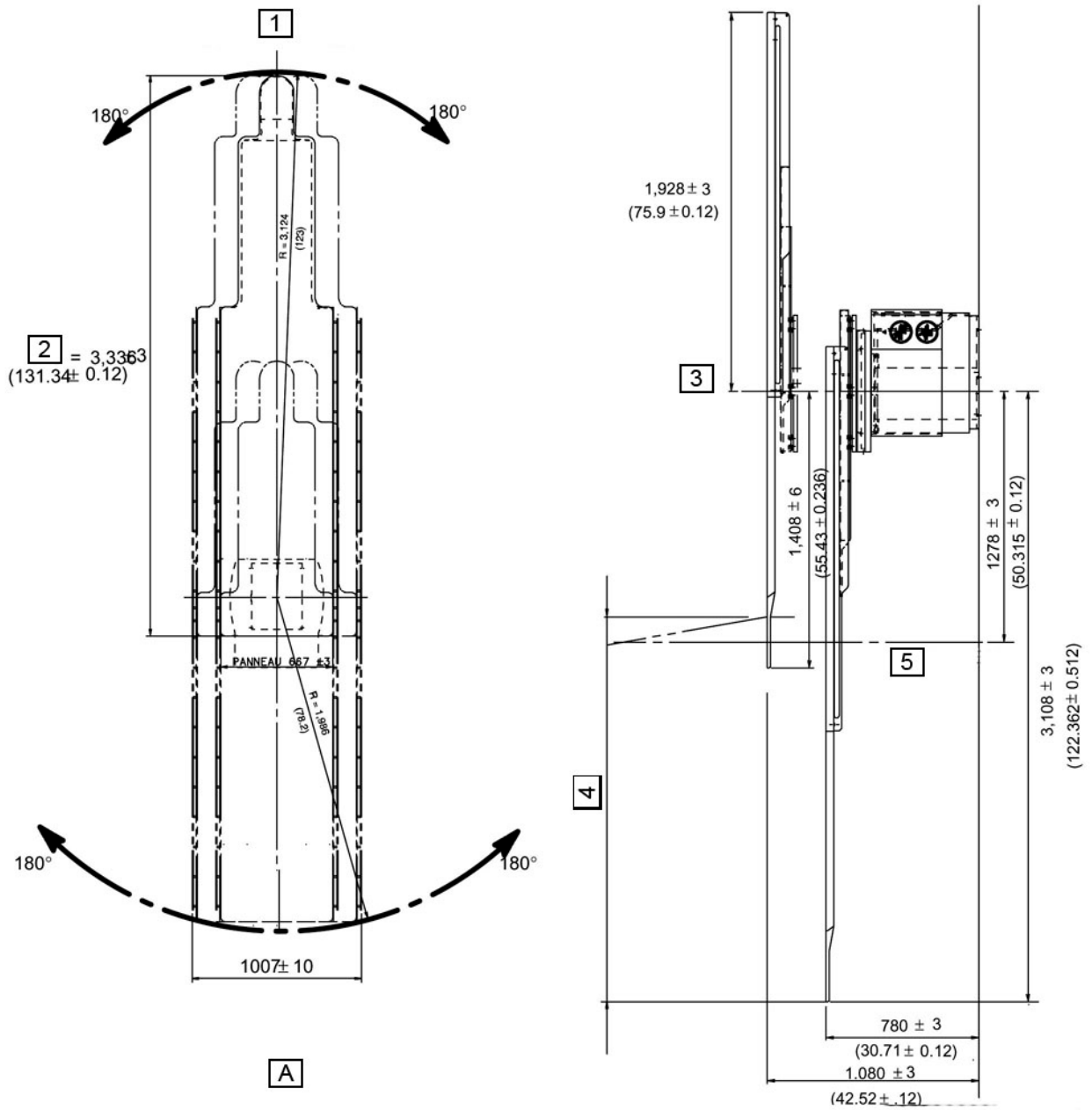
**Figure 36 Omega V Long Patient Table - CoG**



Equipment Requirements

Item	Description
[A]	Side View
[B]	Plan at Base
[1]	Center of Gravity
[2]	Table Base
[3]	Hole diameter: 29 mm (1.14")

Figure 37 Omega V Long Patient Table Interference Regions



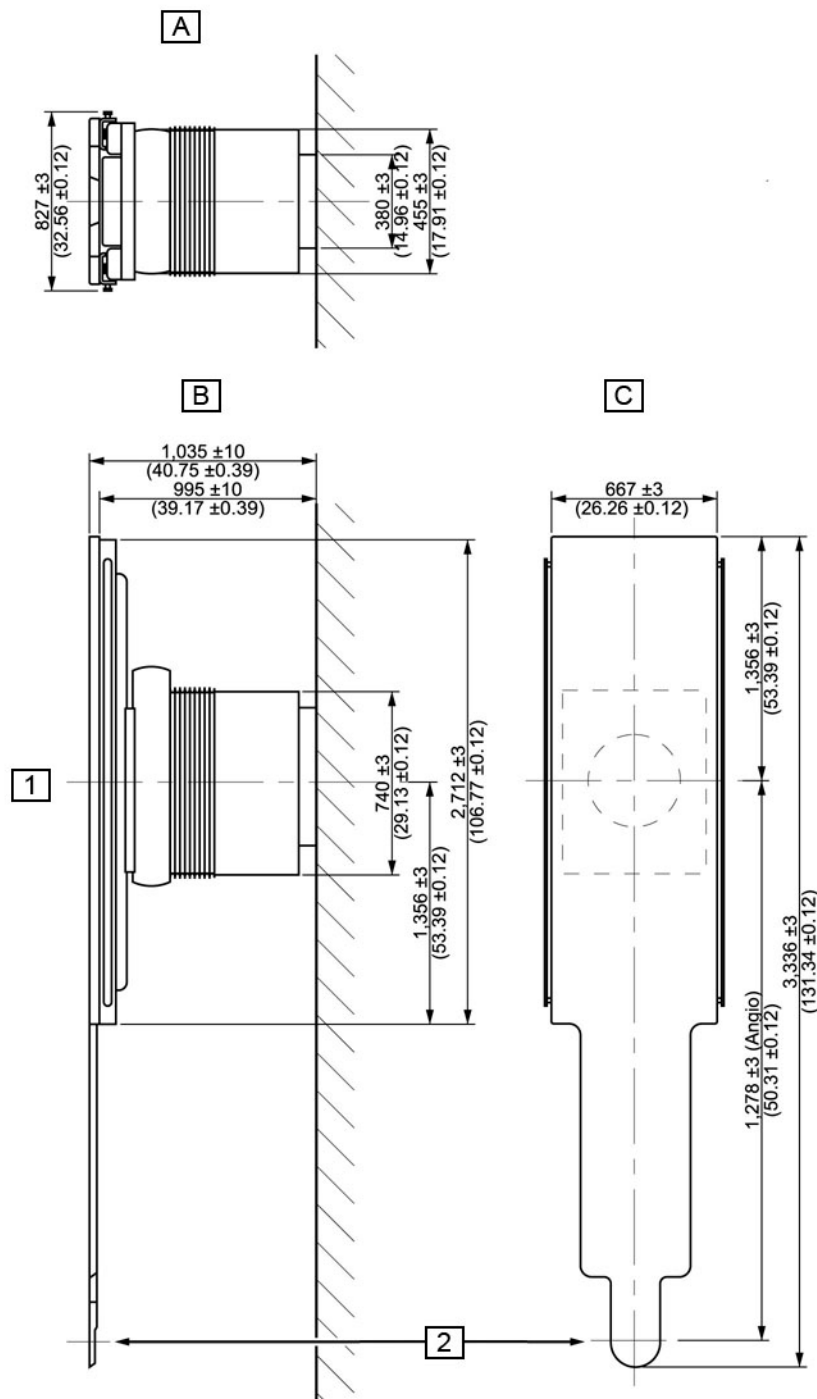
Dimensions in mm (in)

Item	Description
[A]	Top view
[1]	Table rotation
[2]	Table top

Equipment Requirements

(continued)	
Item	Description
[3]	Table pivot
[4]	Patient coverage = 1980 (77.95) between mechanical stops
[5]	LCA isocenter

Figure 38 Innova<sup>IQ</sup> Table - Dimensions



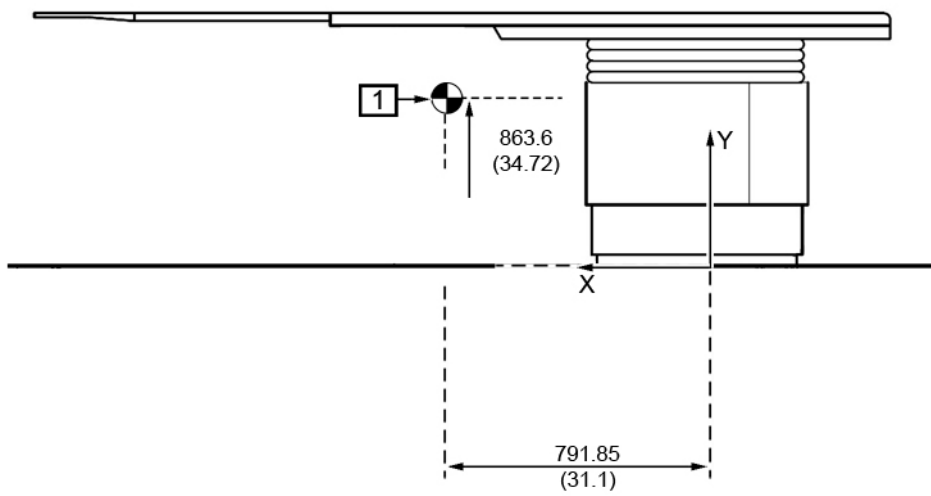
Dimensions in mm (in)

**NOTE**

The table dimensions are correct for the position (longi=0, lat=0, lift=0, tilt=0, rot=0)

Item	Description
[A]	Front view (head end)
[B]	Side view
[C]	Top view
[1]	Table pivot
[2]	LCA isocenter

**Figure 39 Innova<sup>IQ</sup> Table - CoG**

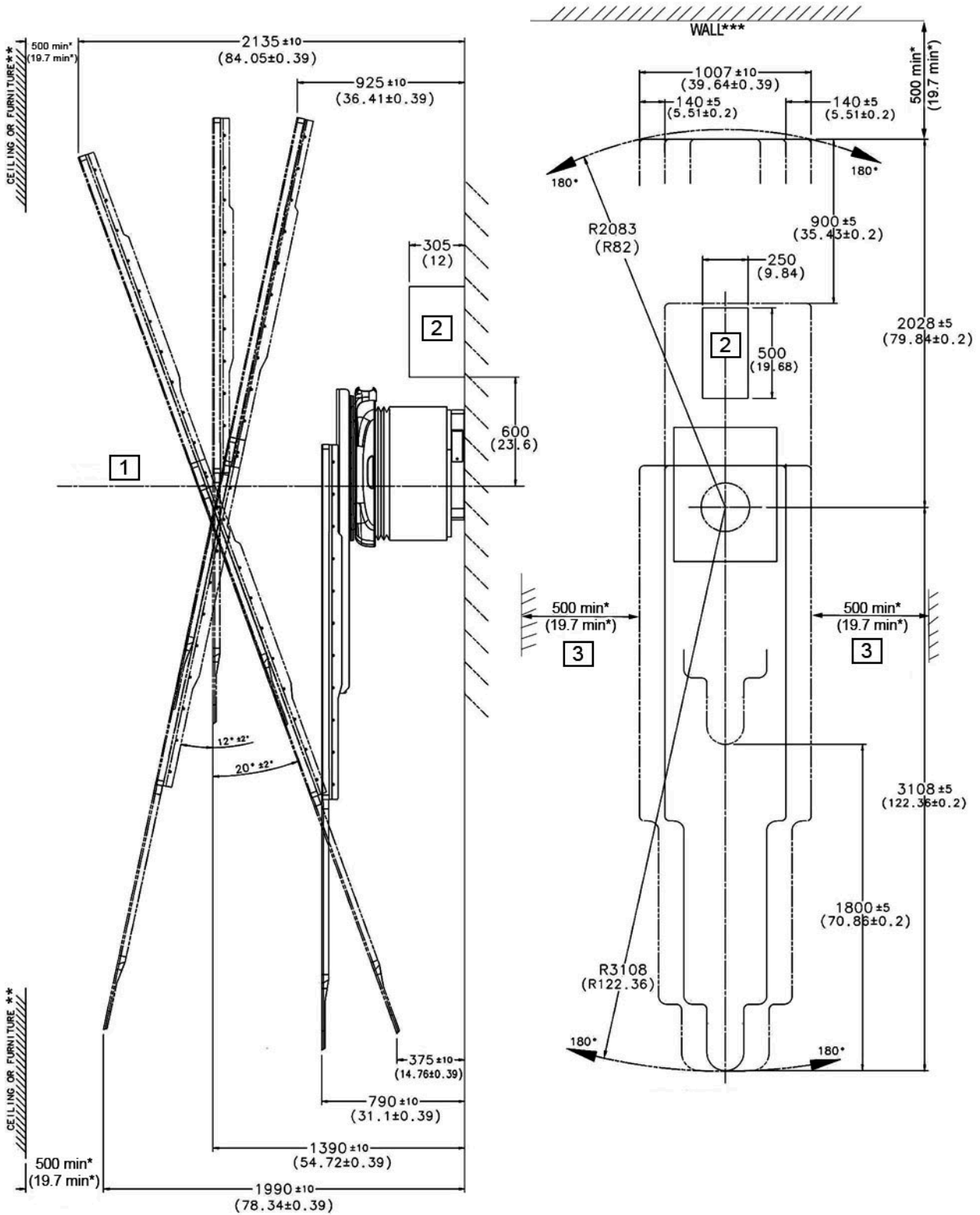


Dimensions in mm (in)

**Table 16**

Item	Description
[1]	Center of Gravity

Figure 40 Innova<sup>IQ</sup> Table Interference Regions

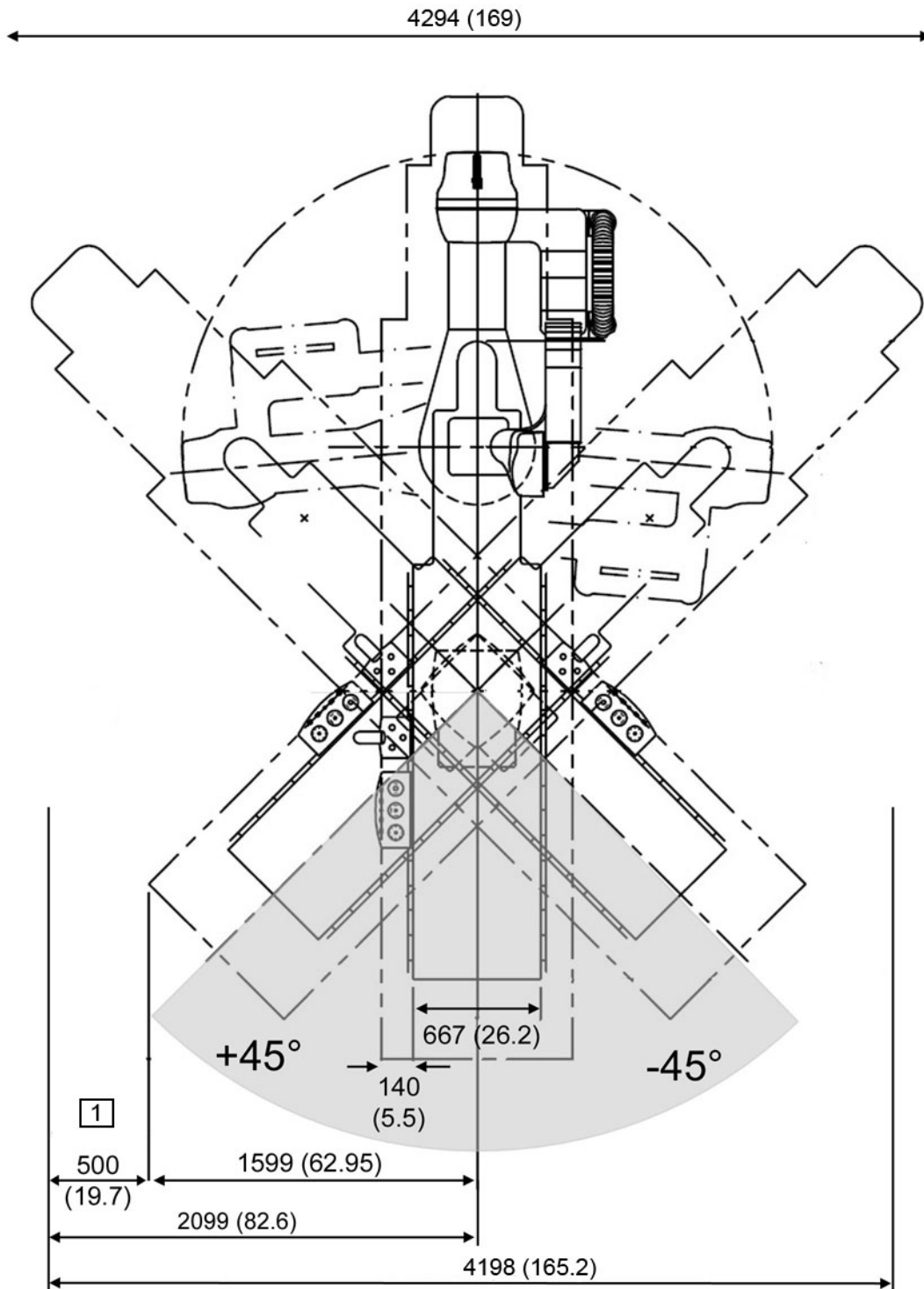


Dimensions in mm (in)

Equipment Requirements

Item	Description
[1]	Table pivot
[2]	Medical gas box
[3]	Minimum clearance to wall at max rotation
*	Minimum
**	Ceiling or furniture
***	Wall

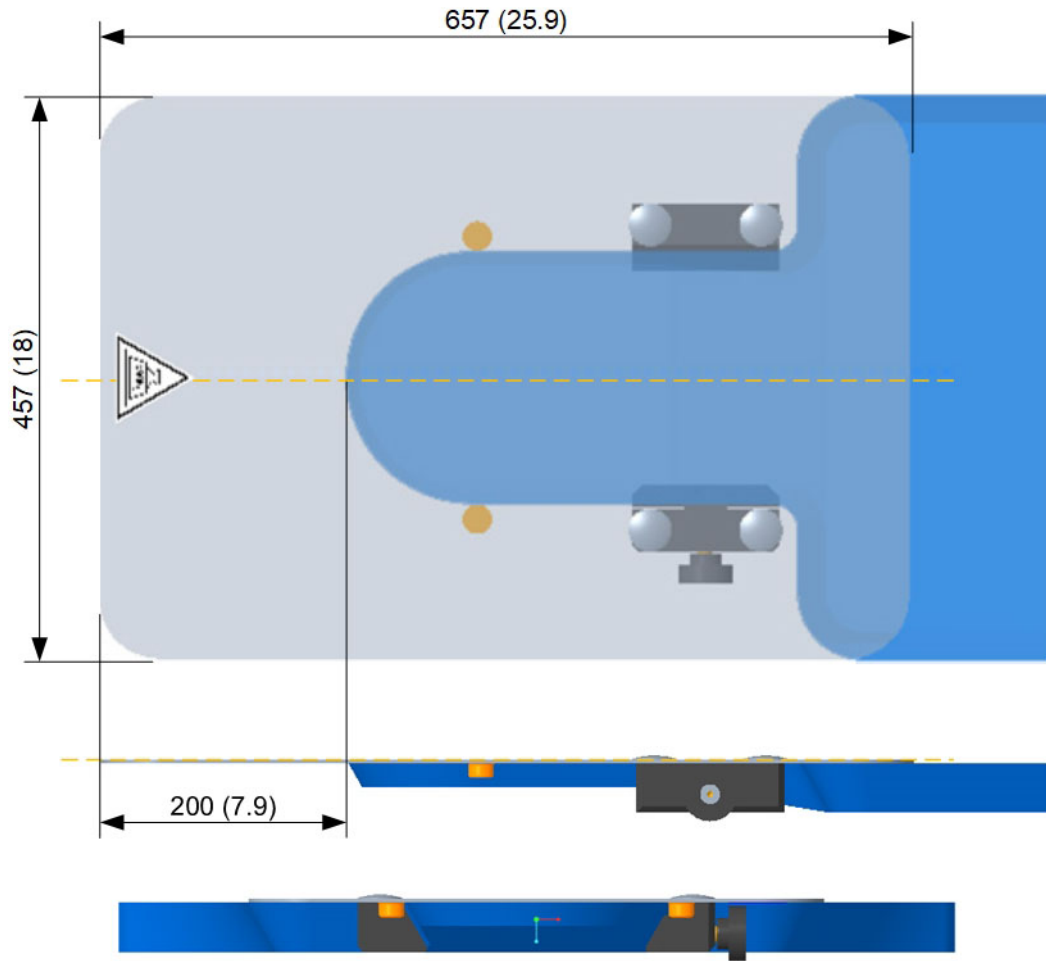
**Figure 41 Patient Table side clearance (CPR access)**



Dimensions in mm (in)

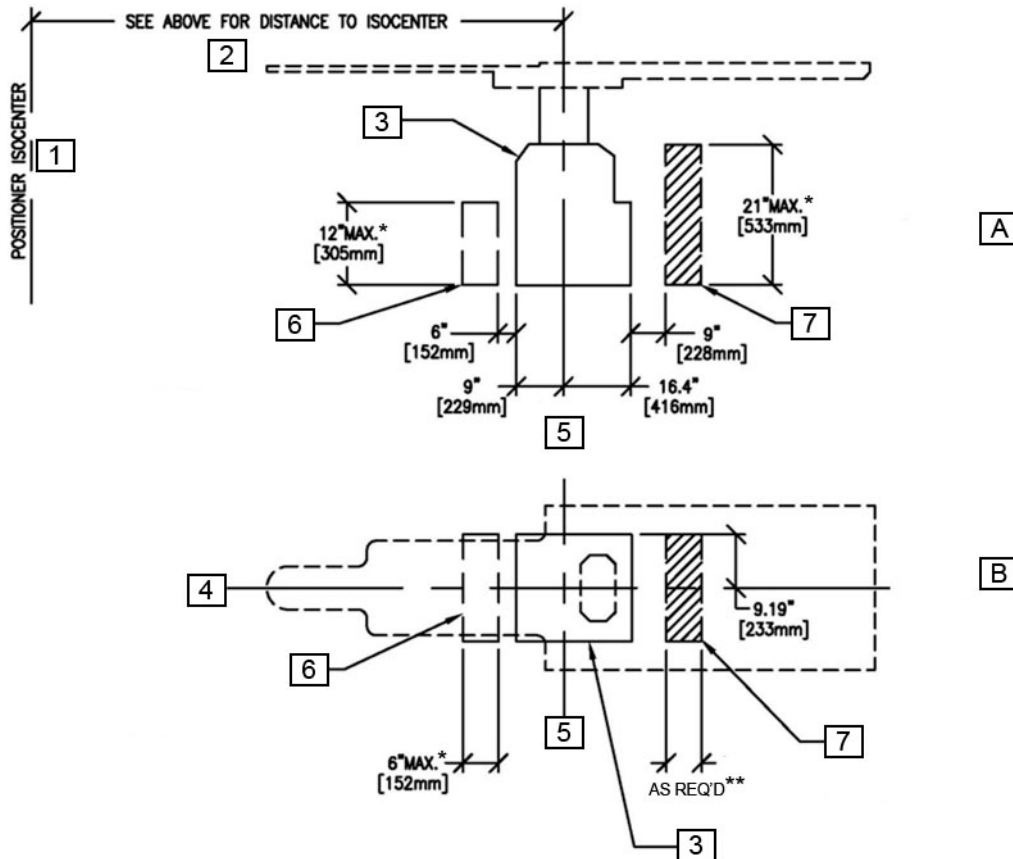
Item	Description
[1]	Clearance

**Figure 42 Table Head Extender - Dimensions - Top view / Side view / Front view**



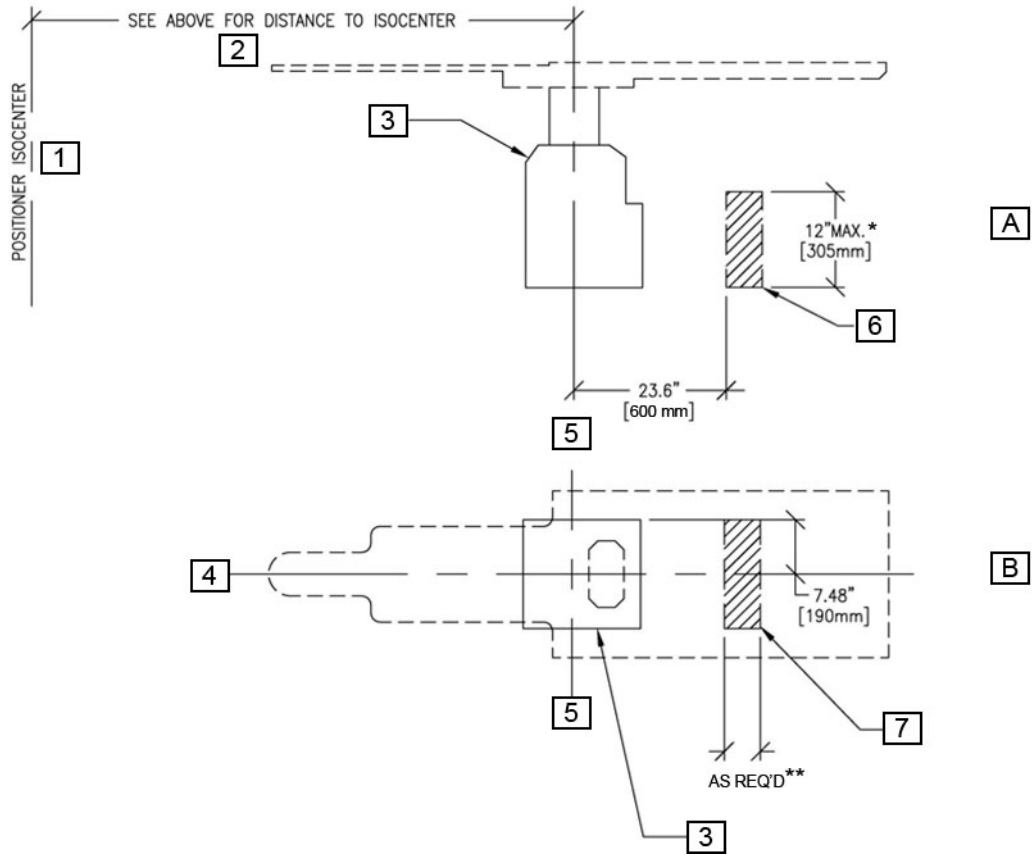
Dimensions in mm (in)

**Figure 43 Gas box outlets Omega IV Table**



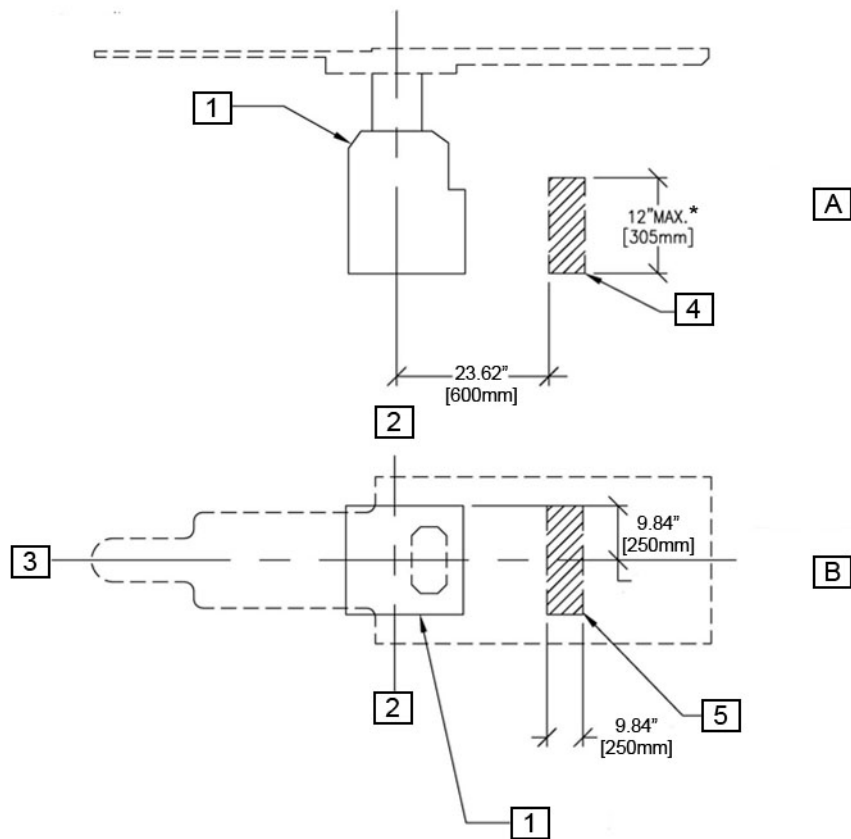
Item	Description
[A]	Side view
[B]	Plan view
[1]	Positioner isocenter
[2]	See above for distance to isocenter
[3]	Table base
[4]	Table CL
[5]	Table pivot CL
[6]	Alternate area for physio. or med. gases, 12" (305 mm) height restriction in this area
[7]	Recommended area for physio. or med. gases, 21" (533 mm) height restriction in this area
*	Maximum
**	As required

**Figure 44 Gas box outlets Omega V Table**



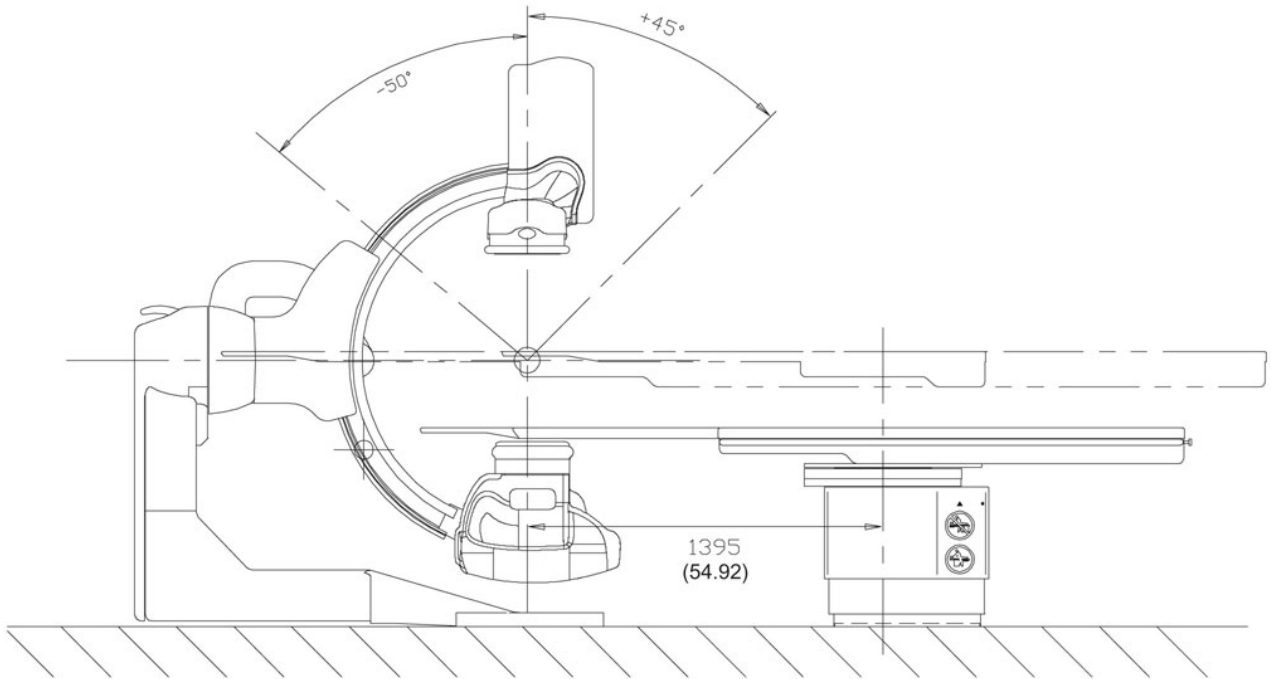
Item	Description
[A]	Side view
[B]	Plan view
[1]	Positioner isocenter
[2]	See above for distance to isocenter
[3]	Table base
[4]	Table CL
[5]	Table pivot CL
[6]	Recommended area for physio. or med. gases, 12" (305 mm) height restriction in this area
[7]	Recommended area for physio. or med. gases
*	Maximum
**	As required

**Figure 45 Gas box outlets Innova IQ Table**



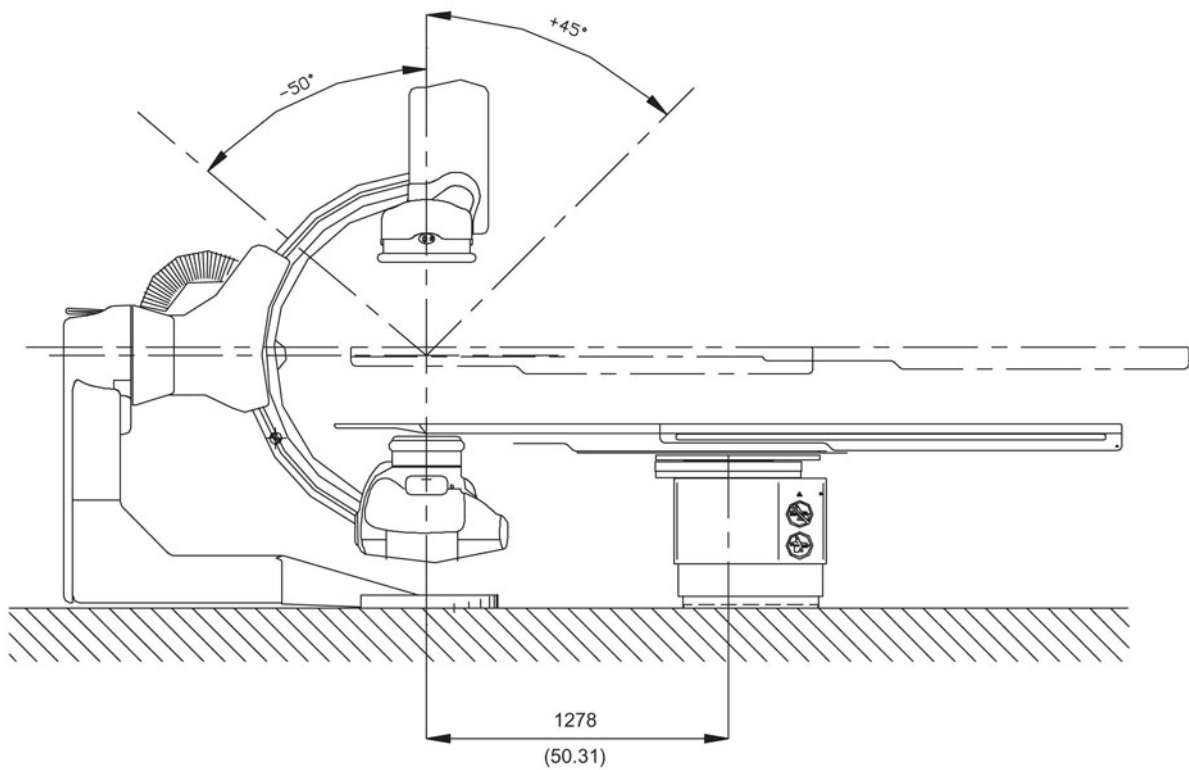
Item	Description
[A]	Side view
[B]	Plan view
[1]	Table base
[2]	Table pivot CL
[3]	Table CL
[4]	Recommended area for physio. or med. gases, 12" (305 mm) height restriction in this area
[5]	Recommended area for physio. or med. gases
*	Maximum

**Figure 46 Gantry and Omega IV Compact Patient Table Relative Positions (Innova IGS 520) - Side View**



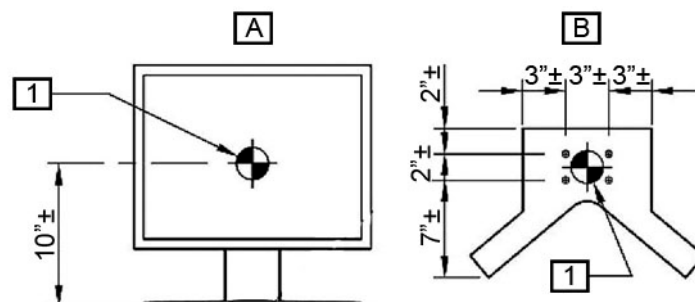
Dimensions in mm (in)

**Figure 47 Gantry and Omega V Long Patient Table Relative Positions - Side View**



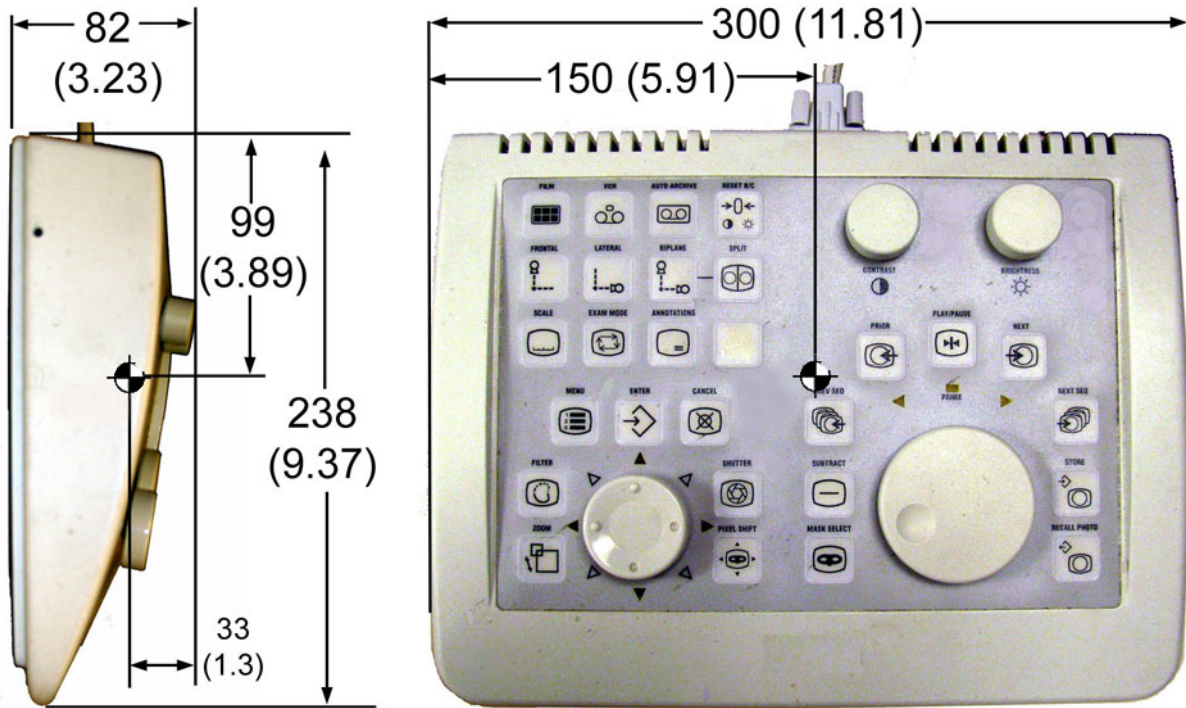
Dimensions in mm (in)

**Figure 48 19" Desk Mounted Monitor - CoG**



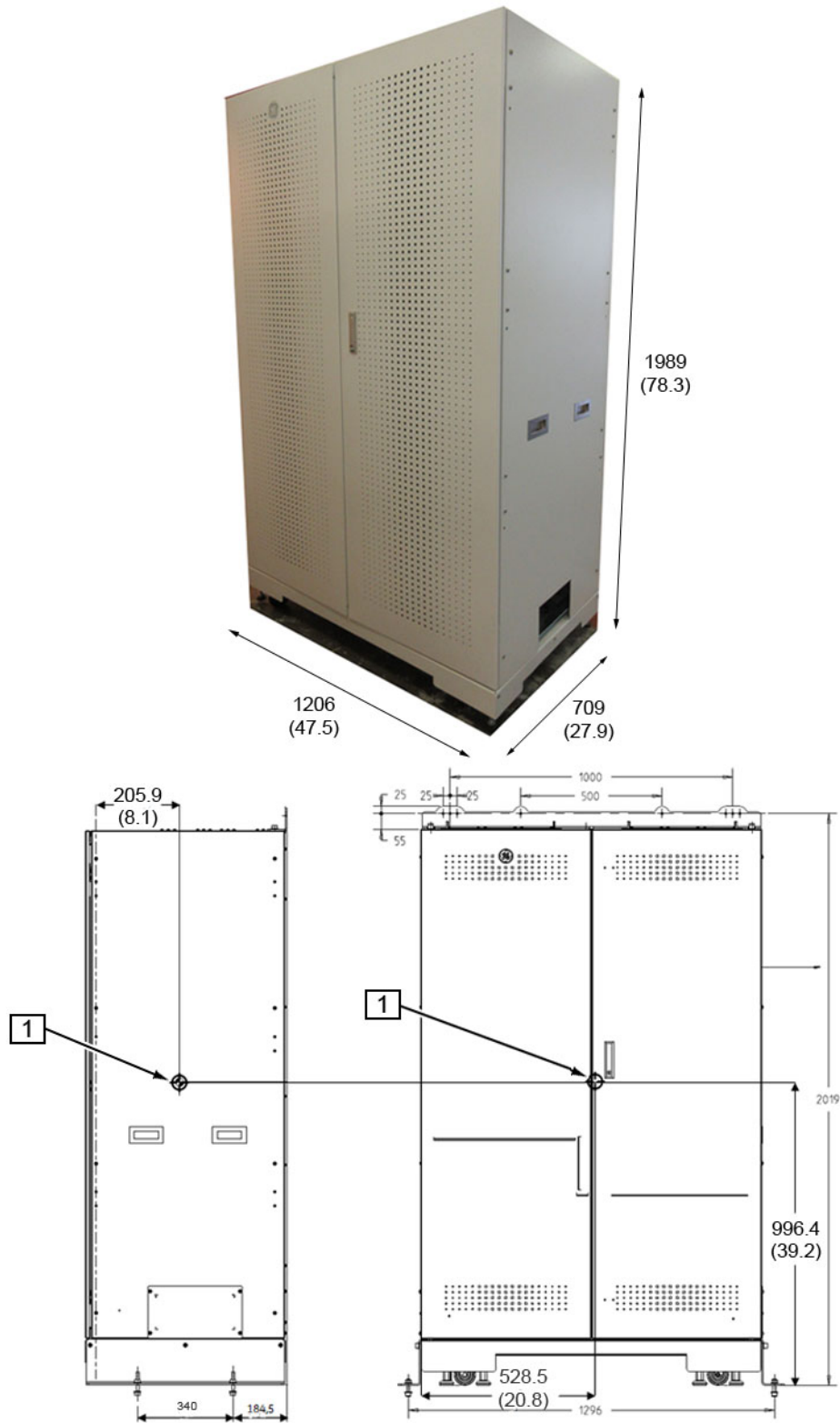
Item	Description
[A]	Front Elevation
[B]	Plan at Base
[1]	Center of Gravity

Figure 49 DL Keypad - Dimensions



Dimensions in mm (in)

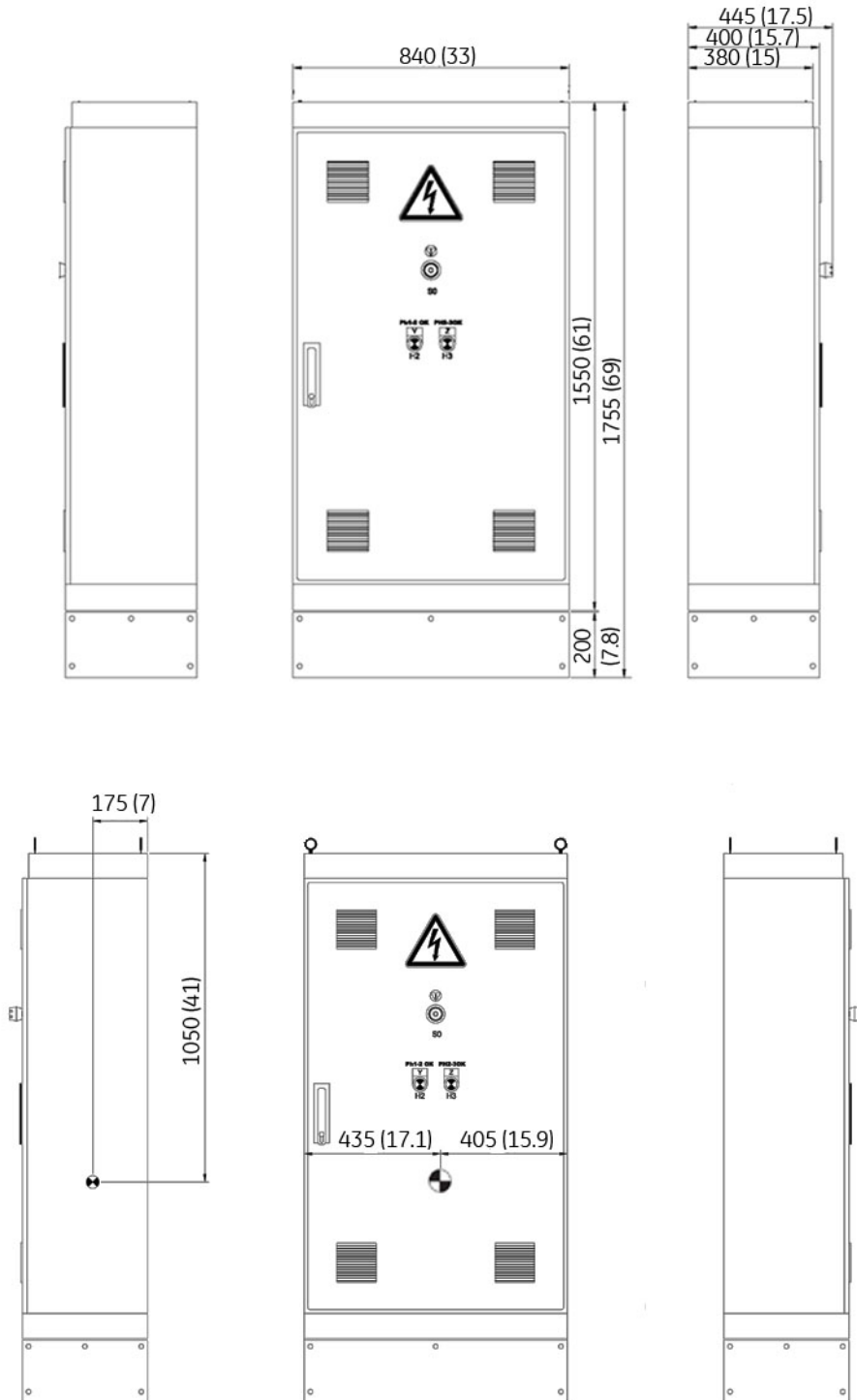
**Figure 50 C-FRT Cabinet - Dimensions and CoG**



Dimensions in mm (in)

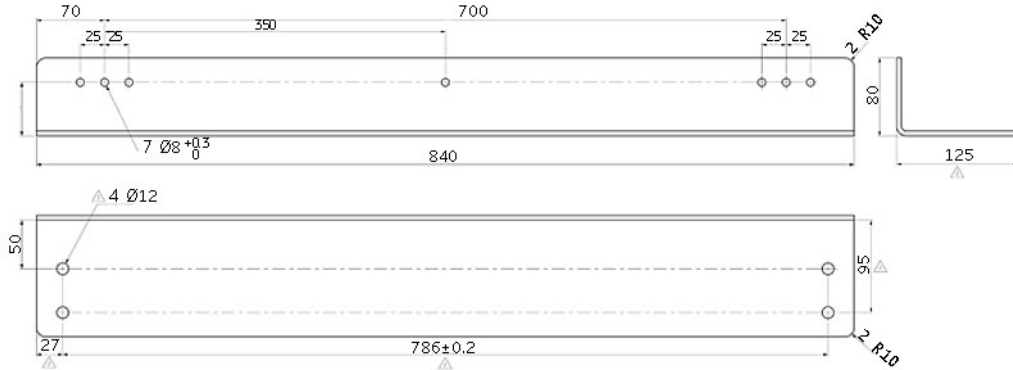
Item	Description
[1]	Center of Gravity

**Figure 51 NPA PDU Cabinet / System Interface Cabinet - Dimensions and CoG - Side View / Front View / Side View**

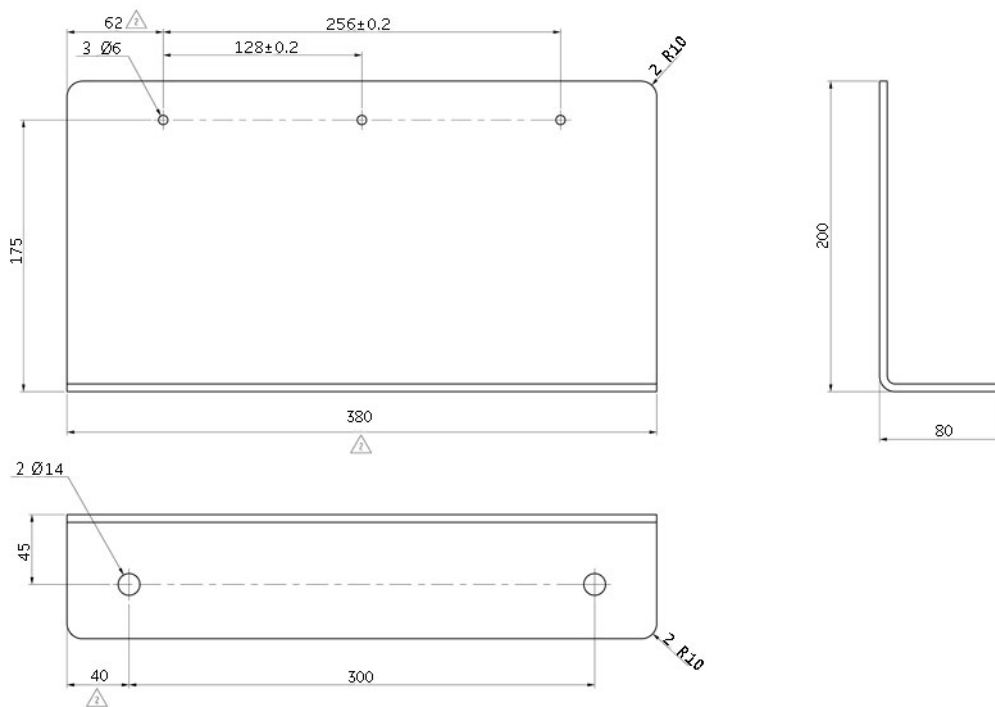


Dimensions in mm (in)

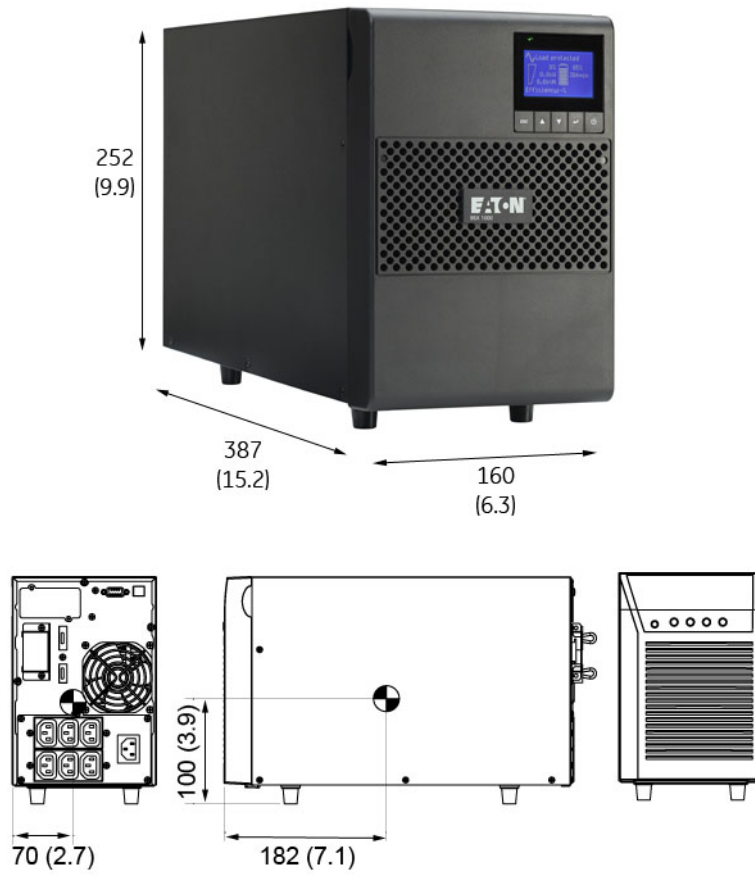
PDU Top bracket (Sheet metal S355MC. 1.0976, thickness 5):



PDU Side bracket (Sheet metal S355MC. 1.0976, thickness 5):

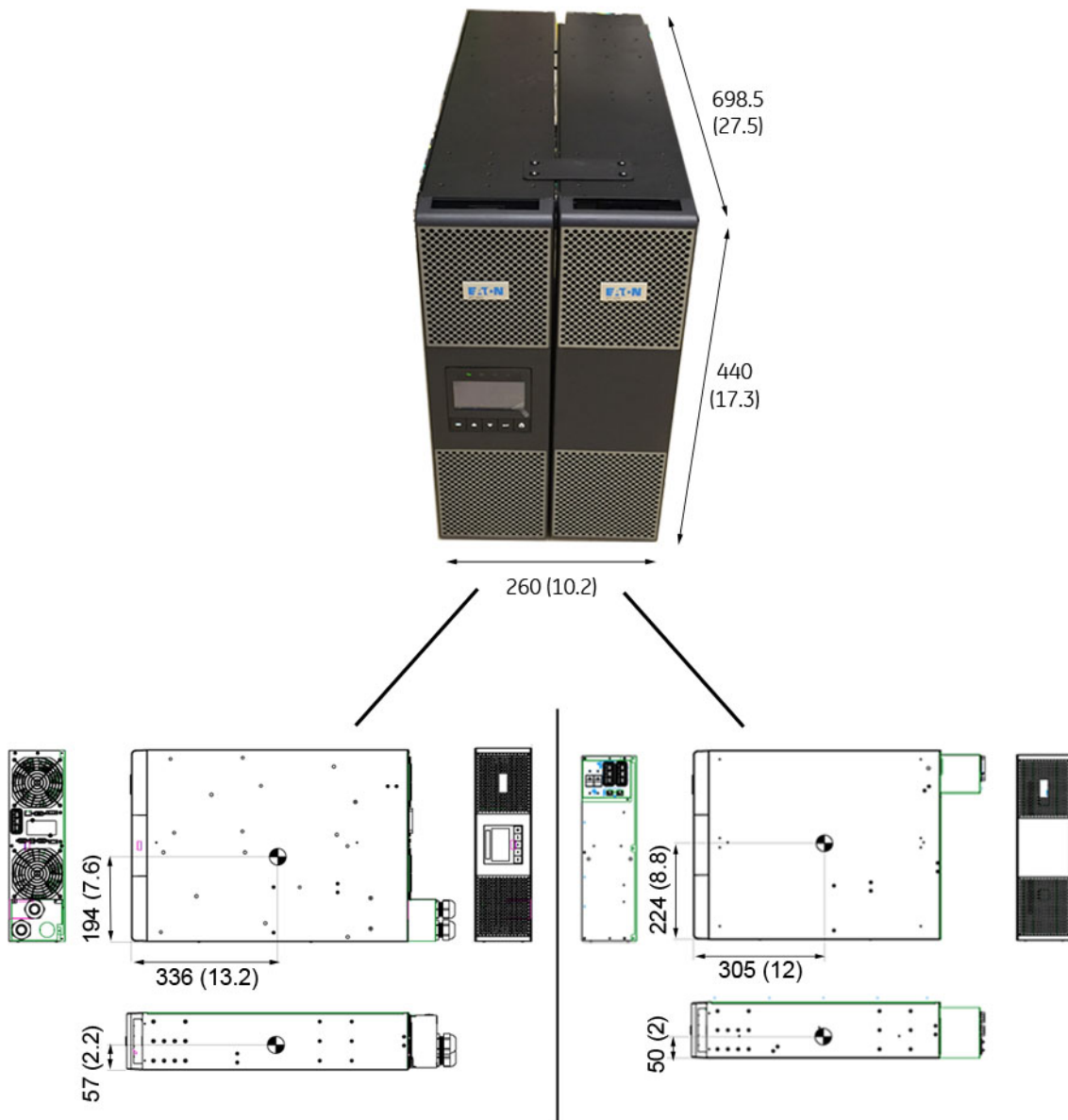


**Figure 52 1 kVA UPS - Dimensions and CoG**



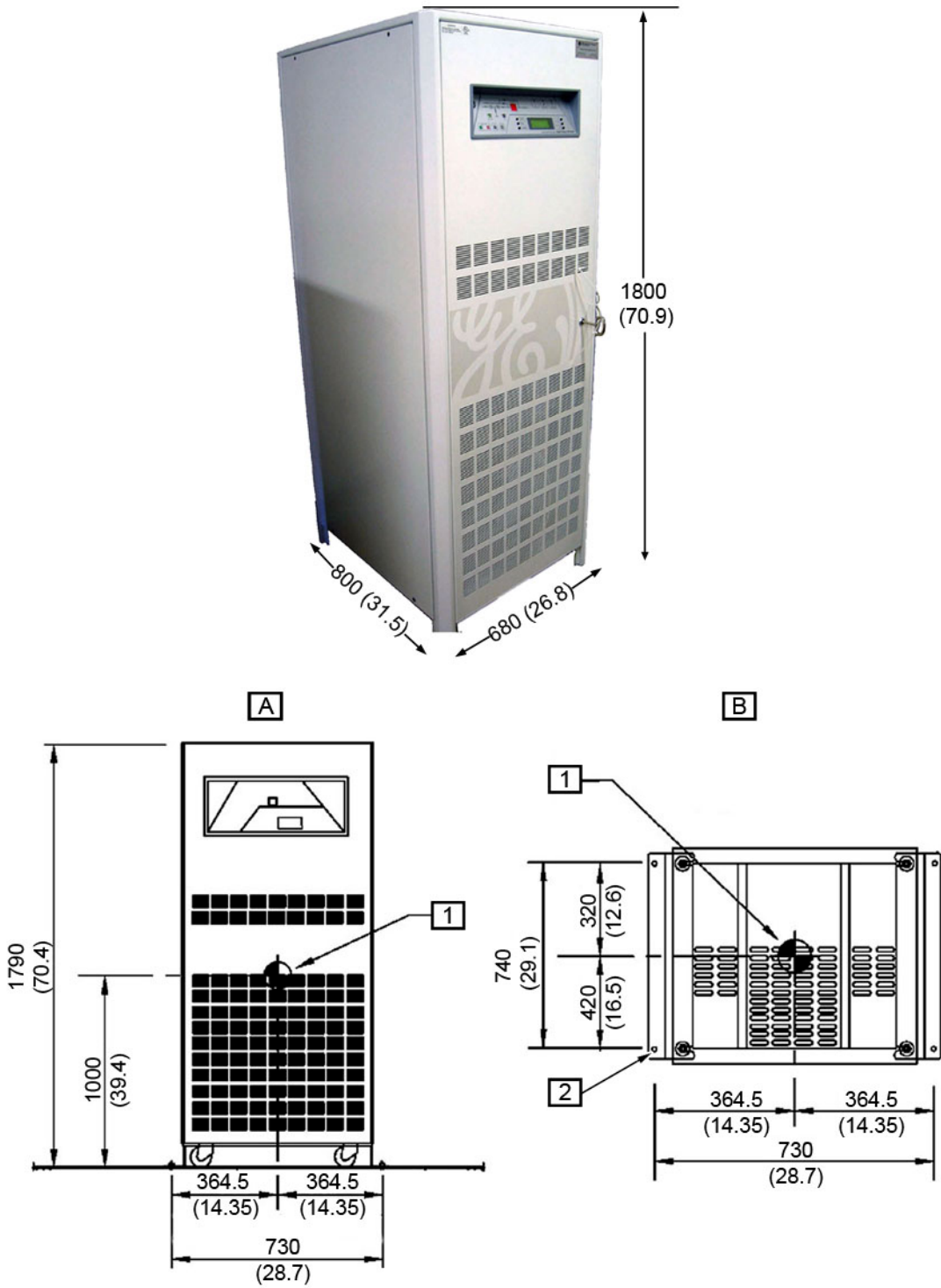
Dimensions in mm (in)

**Figure 53 8 kVA UPS - Dimensions and CoG**

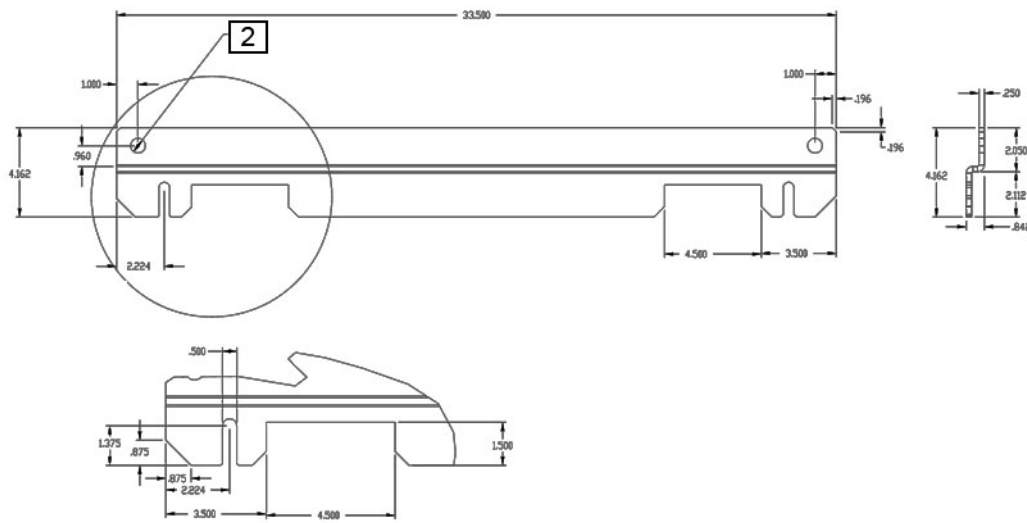


Dimensions in mm (in)

**Figure 54 Fluoro UPS UL - Dimensions and CoG**

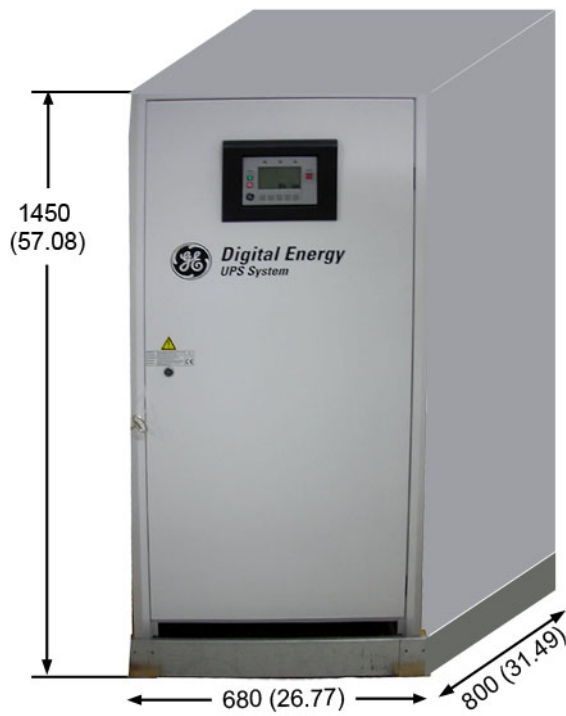


Dimensions in mm (in)

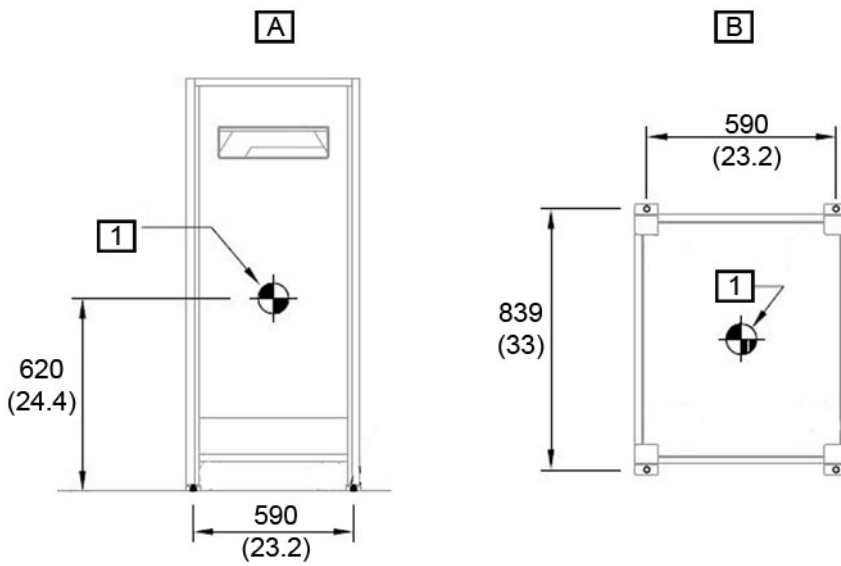


Item	Description
[A]	Front Elevation
[B]	Plan at Base
[1]	Center of Gravity
[2]	Seismic bracket hole diameter: 0.687 inches

**Figure 55 Fluoro UPS CE - Dimensions and CoG**



Equipment Requirements



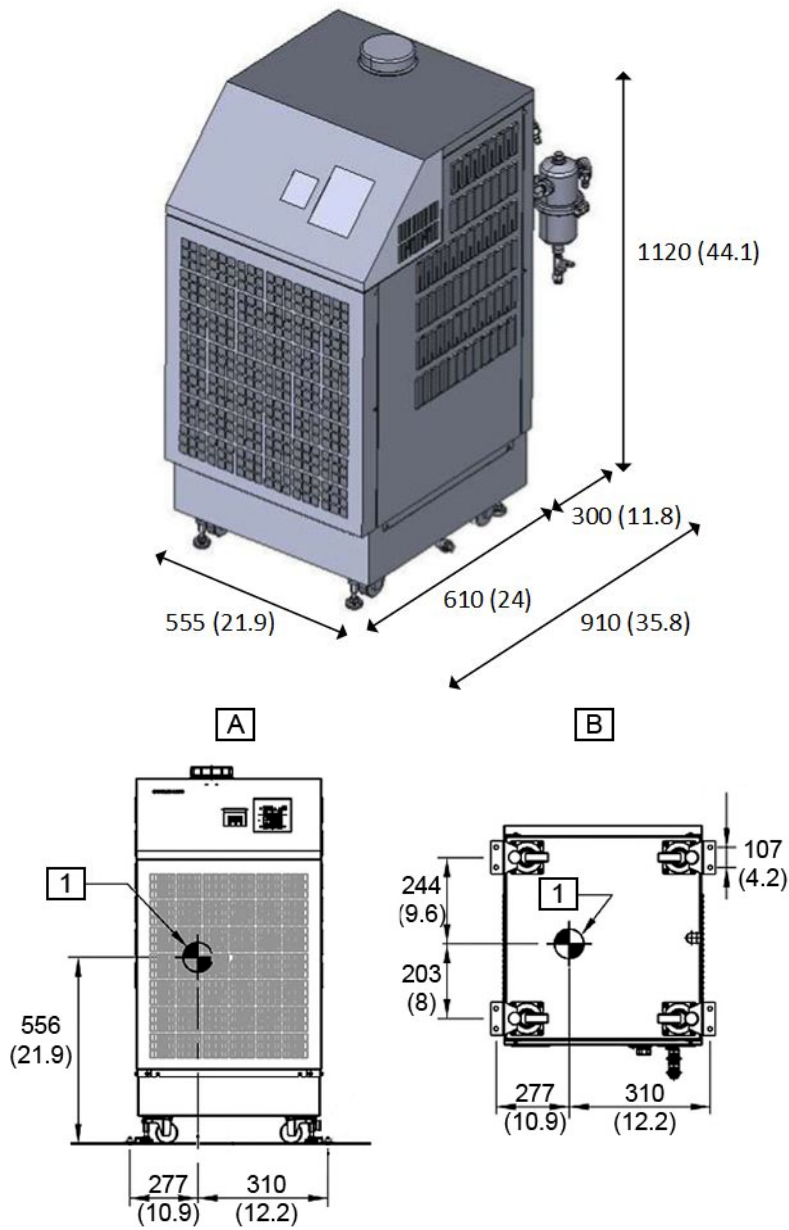
Dimensions in mm (in)

Item	Description
[A]	Front Elevation
[B]	Plan at Base
[1]	Center of Gravity

**NOTE**

A Fire extinguisher (non-water type, ex. CO<sup>2</sup>) must<sup>1</sup> be installed close to the Fluoro UPS CE cabinet.

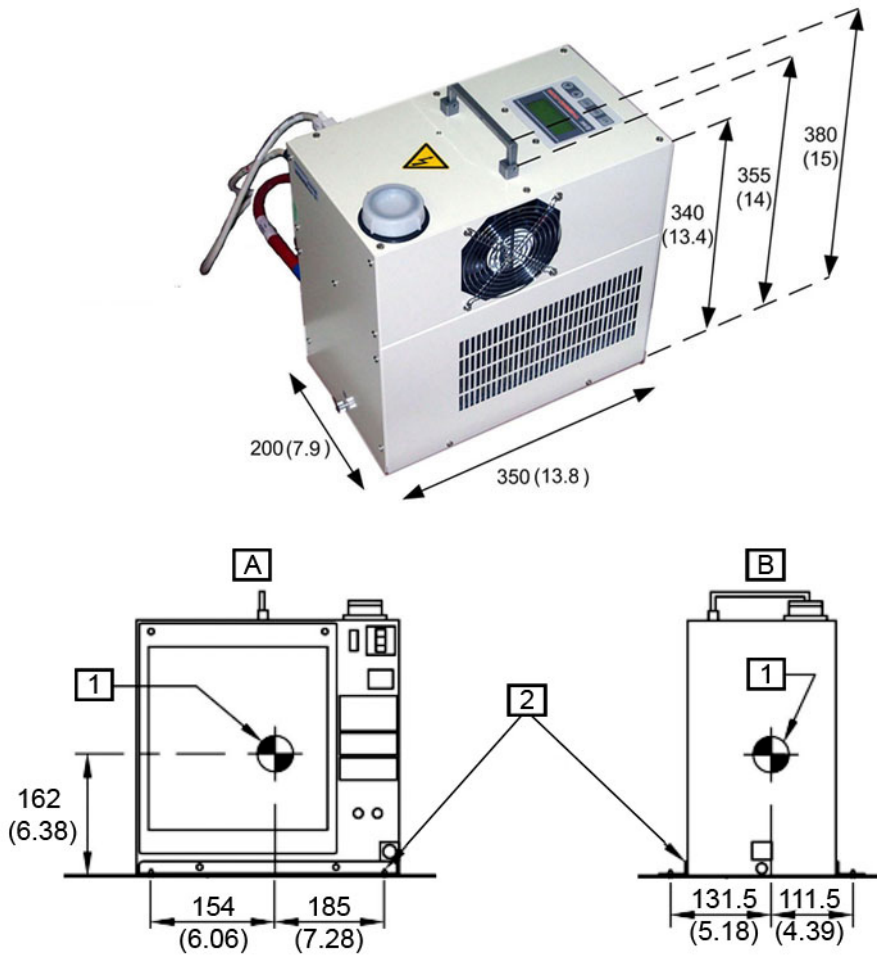
**Figure 56 X-Ray Tube Chiller - Dimensions and CoG**



Dimensions in mm (in)

Item	Description
[A]	Front Elevation
[B]	Plan at Base
[1]	Center of Gravity

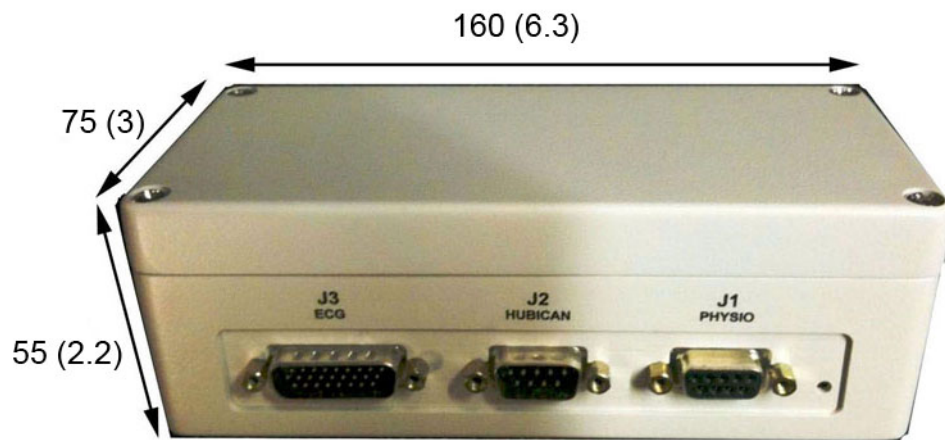
**Figure 57 Detector Conditioner - Dimensions and CoG**



Dimensions in mm (in)

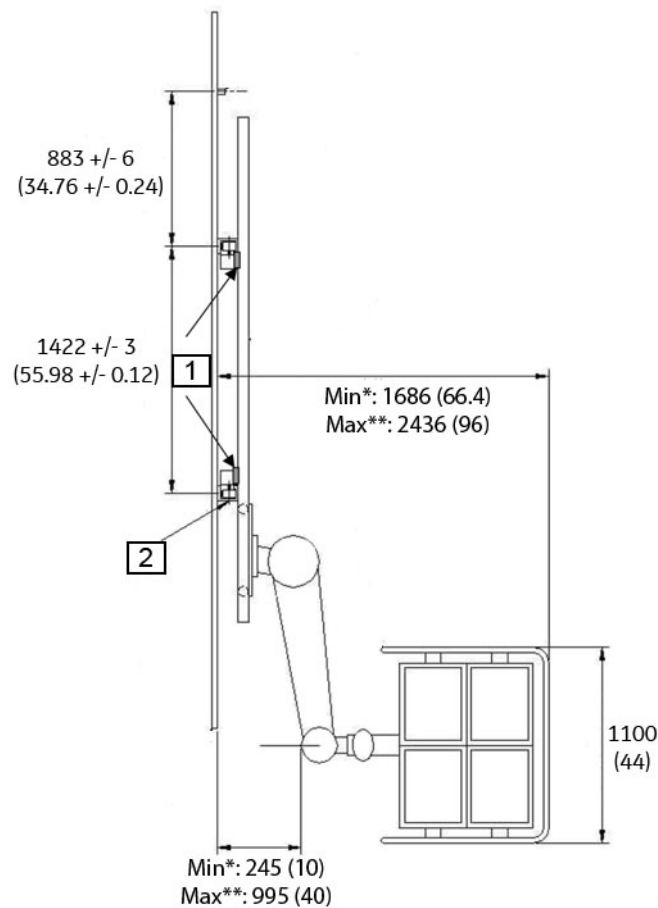
Item	Description
[A]	Front Elevation
[B]	Side Elevation
[1]	Center of Gravity
[2]	Pre-manufactured mounting bracket with 4-3/8" Hilti KB-TZ Expansion Anchors (minimum embedment ( $h_{ef}$ )=2")

**Figure 58 ECG Acquisition Device Module - Physio Box dimensions (Optional)**



Dimensions in mm (in)

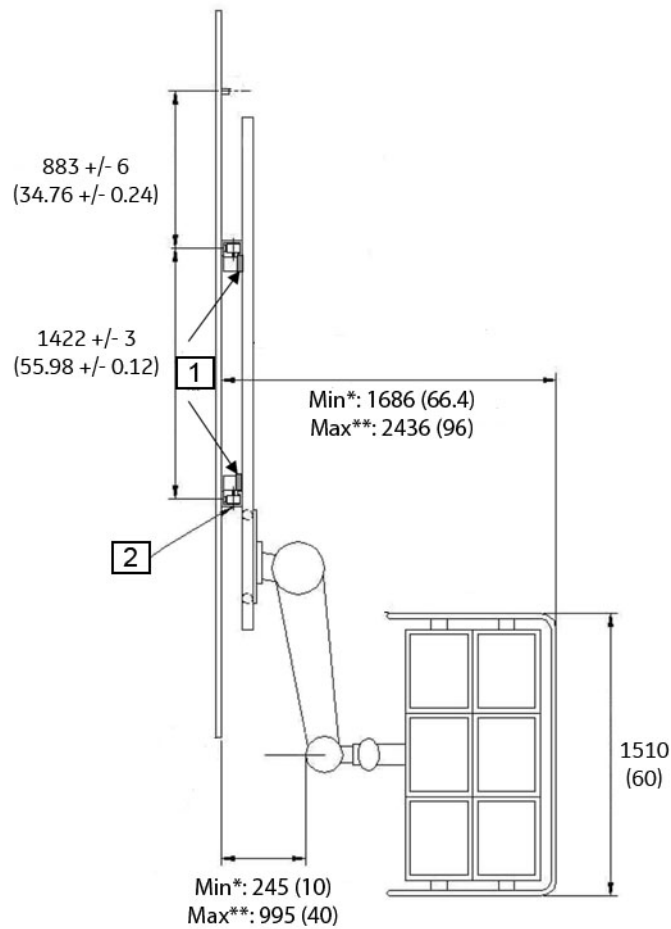
**Figure 59 Suspension with rails for four 19" monitors - Dimensions (Optional)**



Dimensions in mm (in)

Item	Description
[1]	Optional spacers kit
[2]	XT stationary rail
*	Minimum
**	Maximum

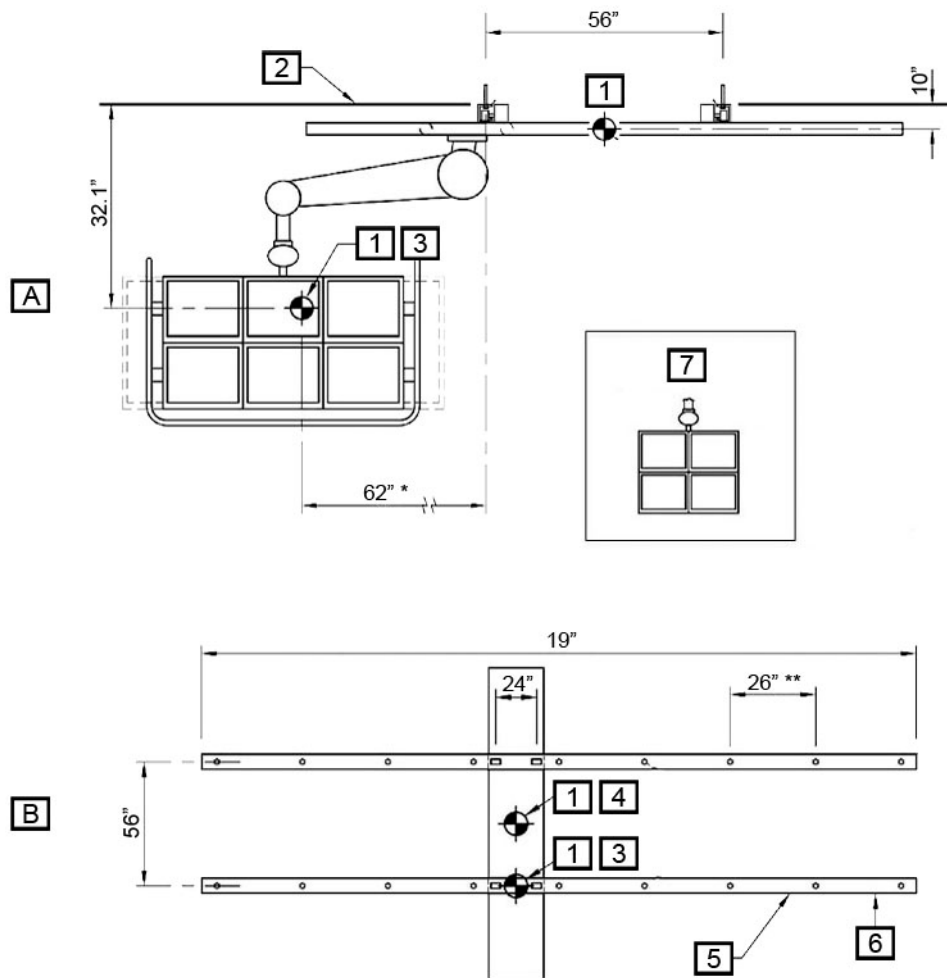
**Figure 60 Suspension with rails for six 19" monitors - Dimensions (Optional)**



Dimensions in mm (in)

Item	Description
[1]	Optional spacers kit
[2]	XT stationary rail
*	Minimum
**	Maximum

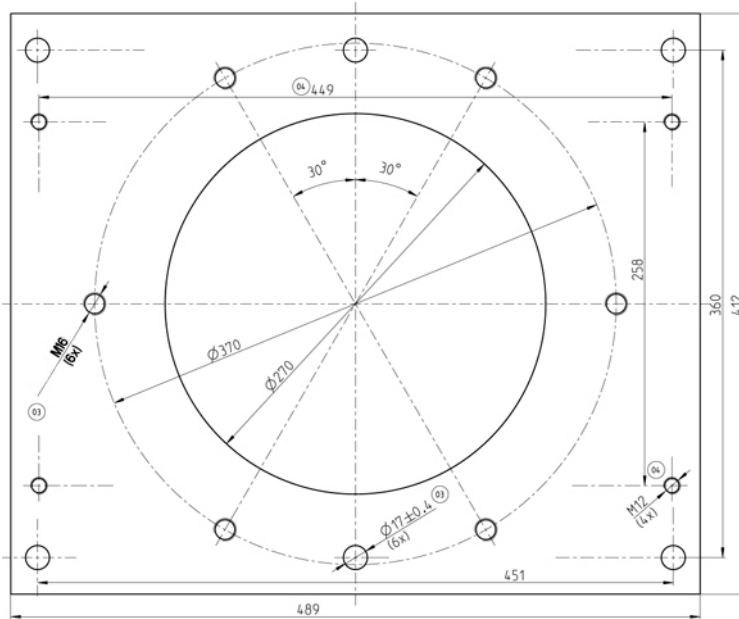
**Figure 61 19" monitors suspension with rails - CoG**



Item	Description
[A]	Elevation
[B]	Plan at Ceiling
[1]	Center of Gravity
[2]	Finished Ceiling
[3]	Monitors and Suspension
[4]	Bridge and Dolly
[5]	Ceiling Track (by GE)
[6]	Longitudinal Rail

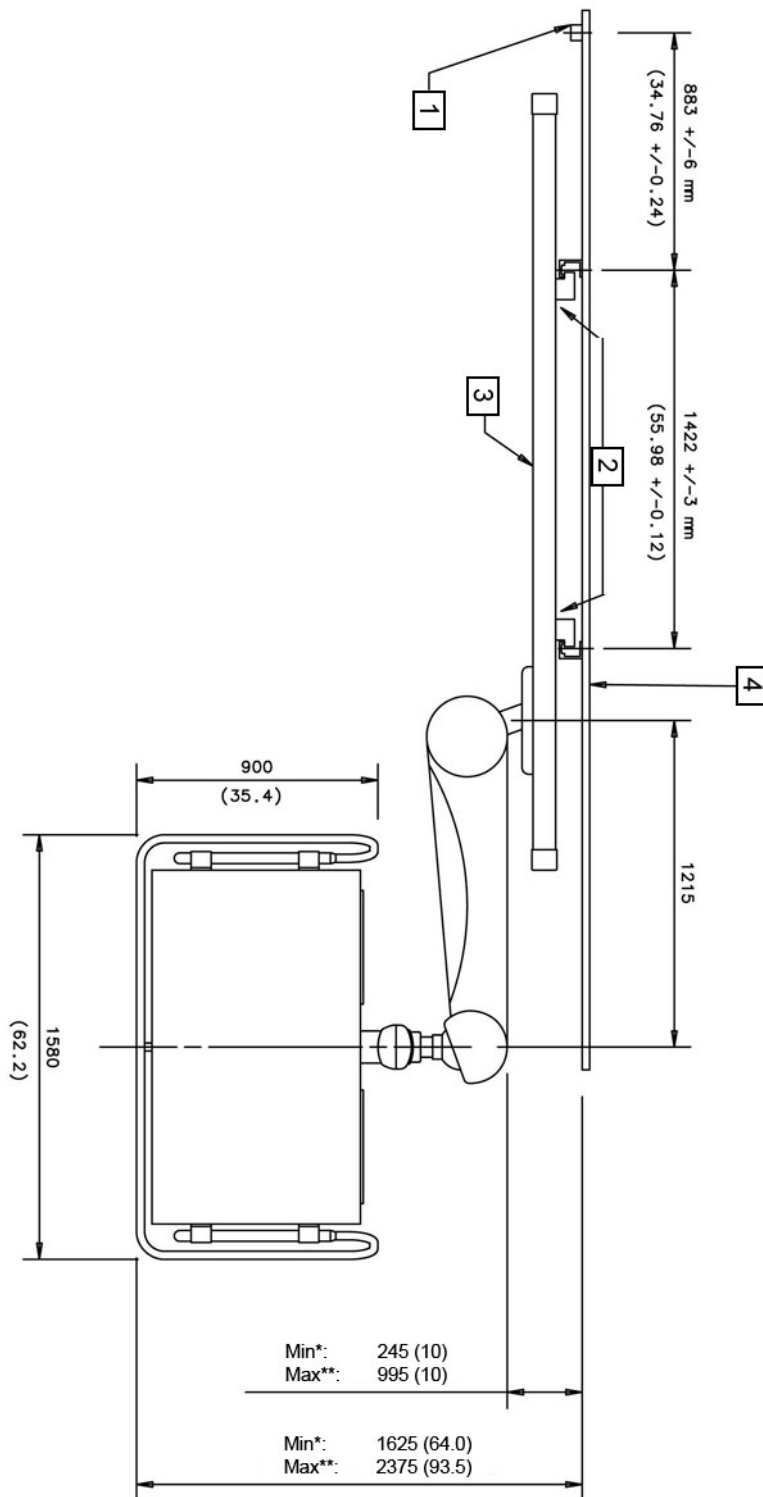
(continued)	
Item	Description
[7]	4 monitors
*	Maximum
**	Typical

**Figure 62 Ceiling Plate of Substructure for Dual Arm suspension - Dimensions**



Dimensions in mm

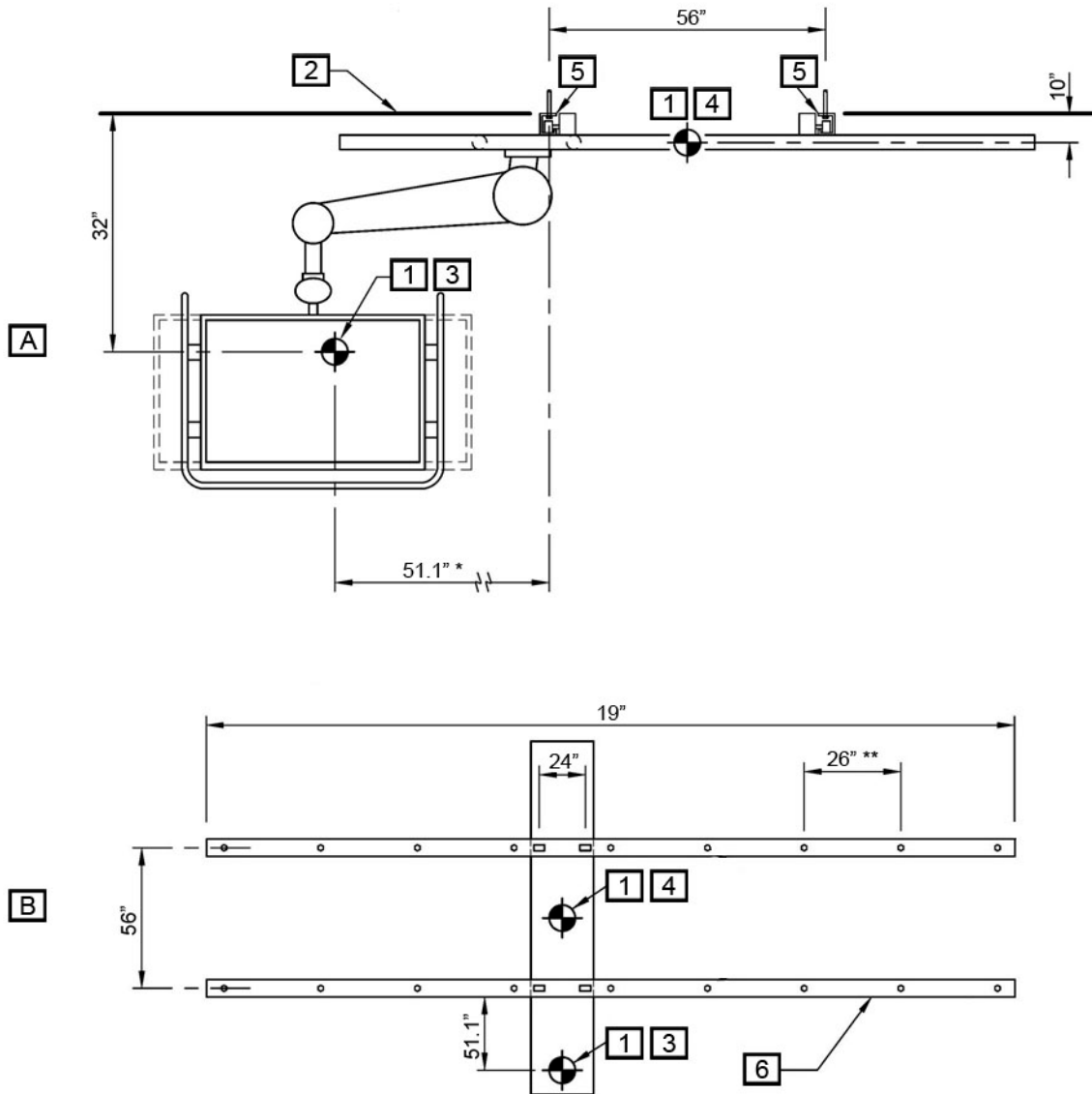
**Figure 63 Large Display Suspension with rails - Dimensions (Optional)**



Dimensions in mm (in)

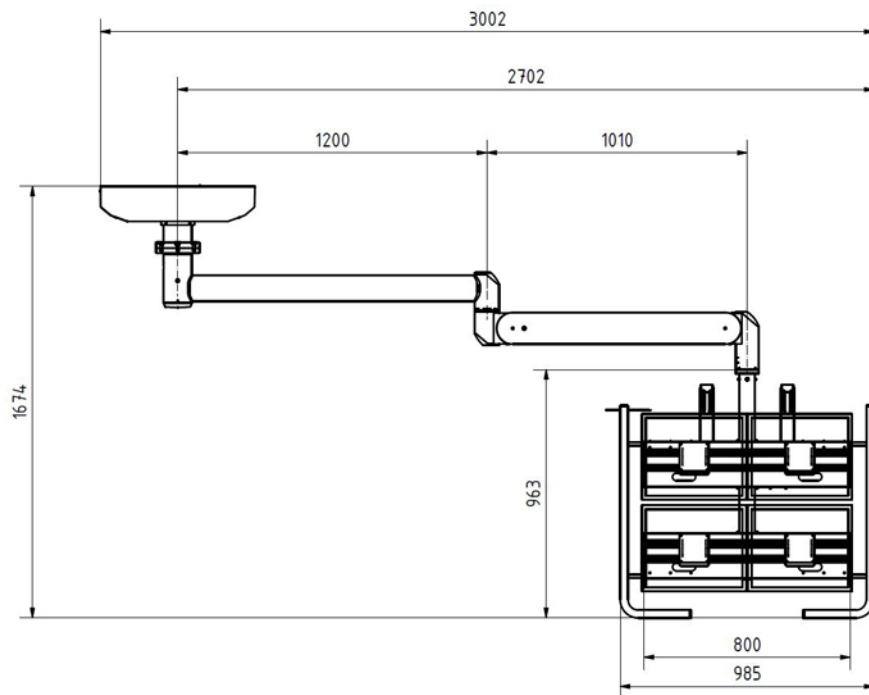
Item	Description
[1]	Support cable drape rails axis (CPEGE55)
[2]	Optional spacer kit
[3]	XT stationary rail
[4]	HALFEN or UNISTRUT structure
*	Minimum
**	Maximum

**Figure 64 Large Display Suspension with rails - CoG**



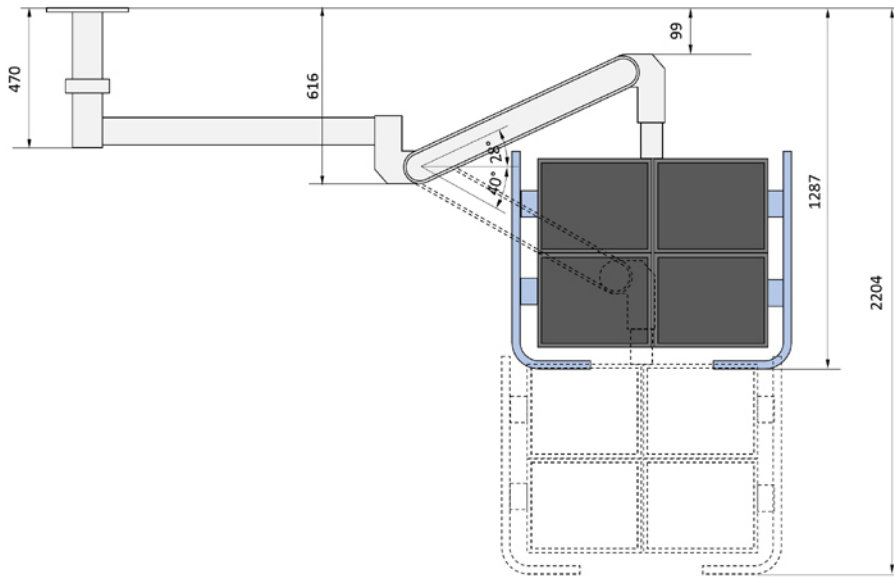
Item	Description
[A]	Elevation
[B]	Plan at Ceiling (ceiling mounted)
[1]	Center of Gravity
[2]	Finished Ceiling
[3]	Monitors and Suspension
[4]	Bridge and Dolly
[5]	Longitudinal Rail
[6]	Ceiling Track (by GE)
*	Maximum
**	Typical

**Figure 65 MAVIG suspension with fixed point dual arm for four 19" monitors - Dimensions (Optional) (1/2)**



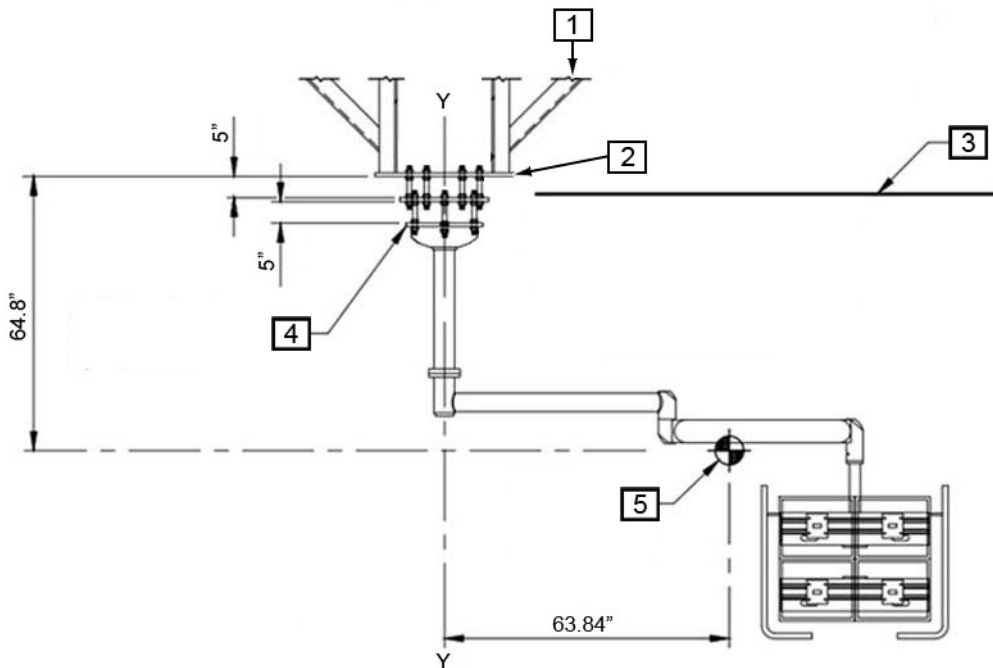
Dimensions in mm

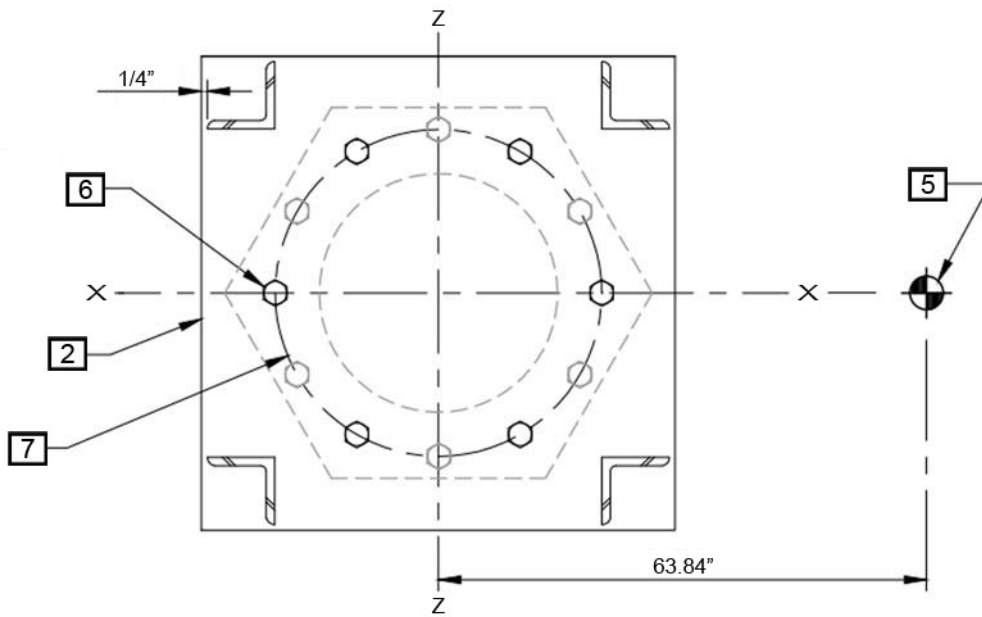
**Figure 66 MAVIG suspension with fixed point dual arm for four 19" monitors - Dimensions (Optional) (2/2)**



Dimensions in mm

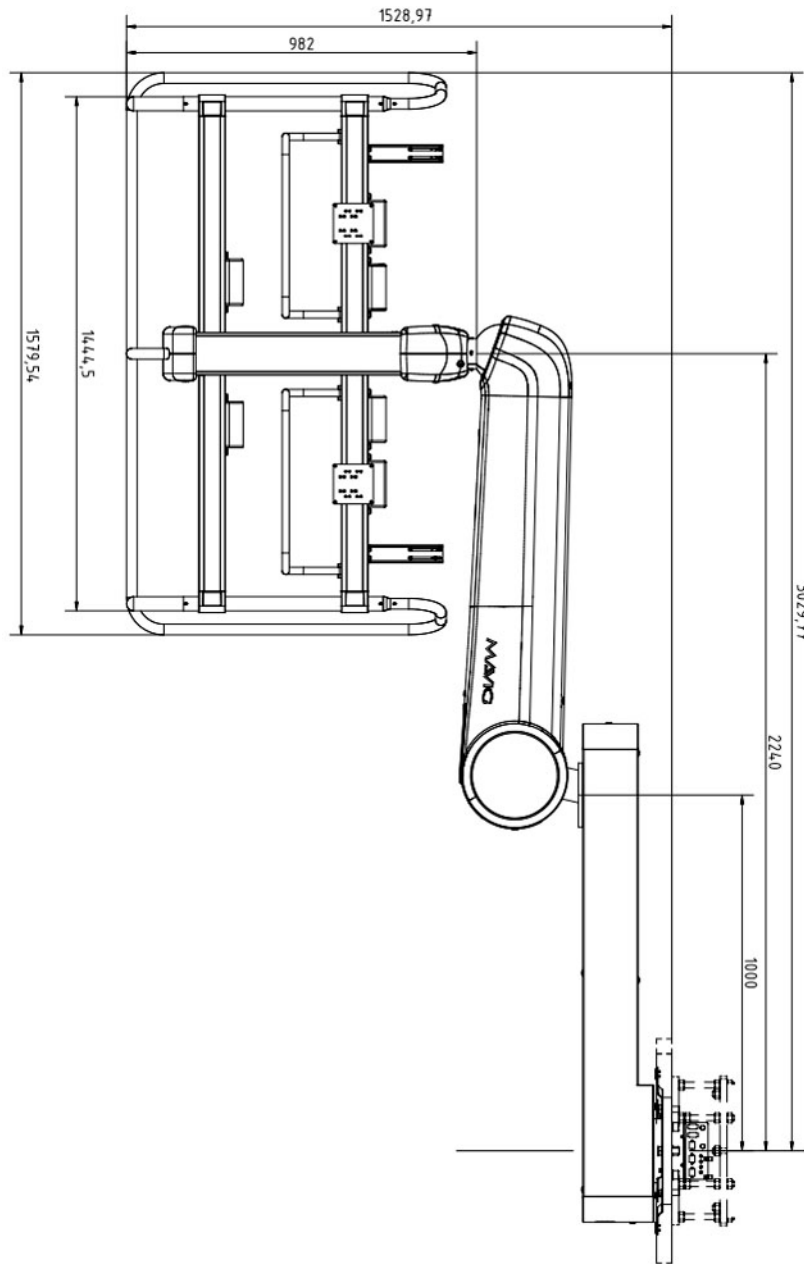
**Figure 67 MAVIG suspension with fixed point dual arm for four 19" monitors - CoG**



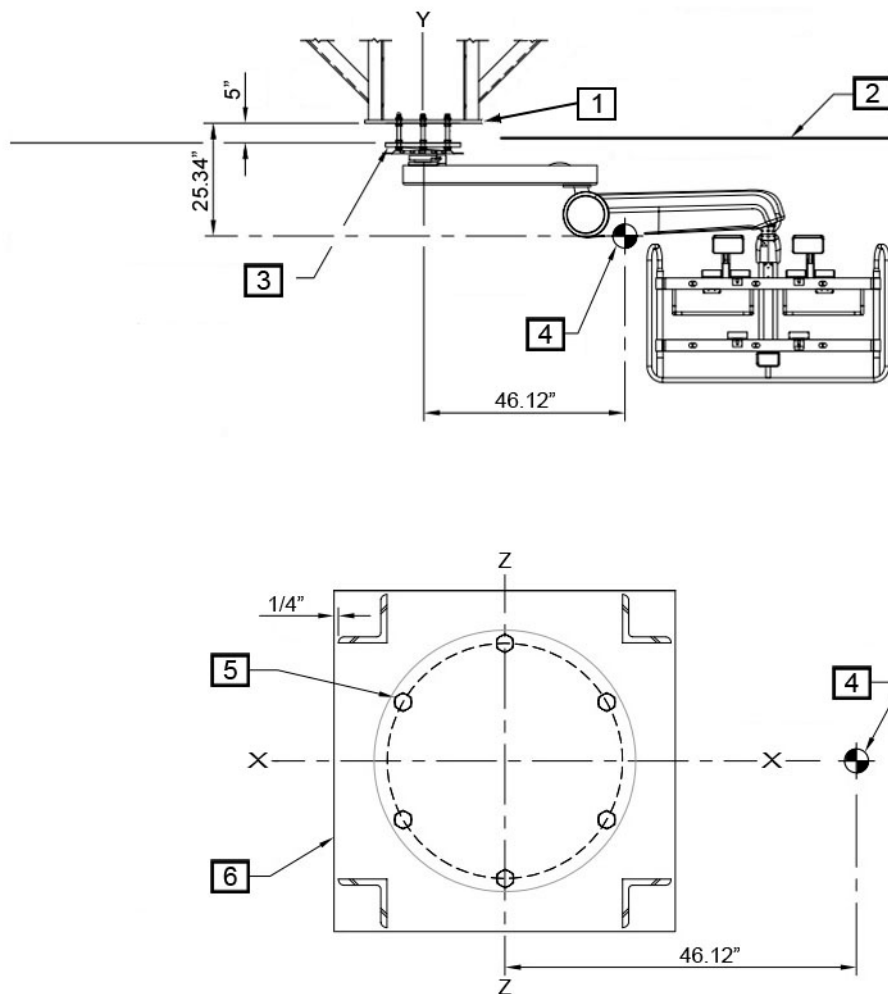


Item	Description
[1]	Structural Bracing System
[2]	Structural Plate: 19" x 1" x 1'-7" (A36 MIN)
[3]	Finished Ceiling
[4]	Ceiling Flange Plate: 20 mm THK, S235JR Steel, $F_y=52$ ksi MIN
[5]	Center of Gravity
[6]	Use 6- M16 (GR 8.8) threaded rods from adapter plate to support structure
[7]	14.57" diameter bolt circle

**Figure 68 MAVIG suspension with fixed point dual arm for Large Display Monitor - Dimensions (Optional)**

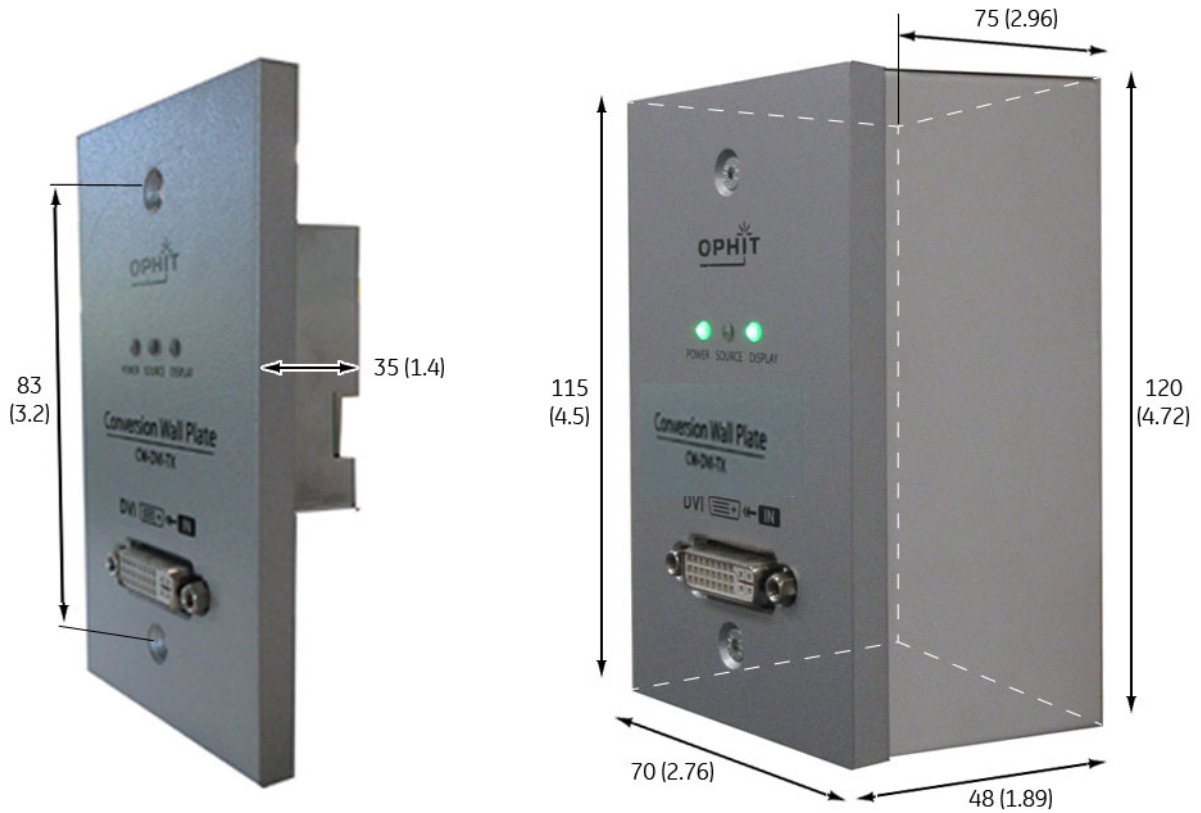


**Figure 69 MAVIG suspension with fixed point dual arm for Large Display Monitor - CoG**



Item	Description
[1]	Structural Support Plate at Support Structure
[2]	Finished Ceiling
[3]	Ceiling Flange Plate: 20 mm THK, S235JR Steel, $F_y=52$ ksi MIN
[4]	Center of Gravity
[5]	Use 6- M16 (GR 12.9) threaded rods from ceiling flange to support structure
[6]	Structural Plate: 19" x 1" x 1'-7" (A36 MIN)

**Figure 70 V-Point Box - Dimensions (Optional)**



Dimensions in mm (in)

## 2.2 Room Layouts

### 2.2.1 Room Dimension Requirements

**Table 17 Exam Room dimensions**

Configuration	Room Length mm (in)		Room Width mm (in)		Ceiling Height mm (in)	
	Recom- mended	Minimum [A]	Recom- mended	Mini- mum	Recom- mended	Minimum
Omega IV table <sup>(1)</sup>	9750 (383.9)	5470 (215.3) [B]	6000 (236.2)	4400 (173.2)	3050 (120.1)	2710 (106.7) with Dual Arm Suspension 2740 (107.9) with rails and Bridge sus- pension
Omega V table <sup>(2)</sup>		6036 (237.6) [C] (+200 (7.9) from head side with Head Ex- tender [E])				

Exam Room dimensions continued						
Configuration	Room Length mm (in)		Room Width mm (in)		Ceiling Height mm (in)	
	Recom- mended	Minimum [A]	Recom- mended	Mini- mum	Recom- mended	Minimum
Innova <sup>IQ</sup> table <sup>(3)</sup>		6136 (241.6) [D] (+200 (7.9) from head side with Head Ex- tender [E])				

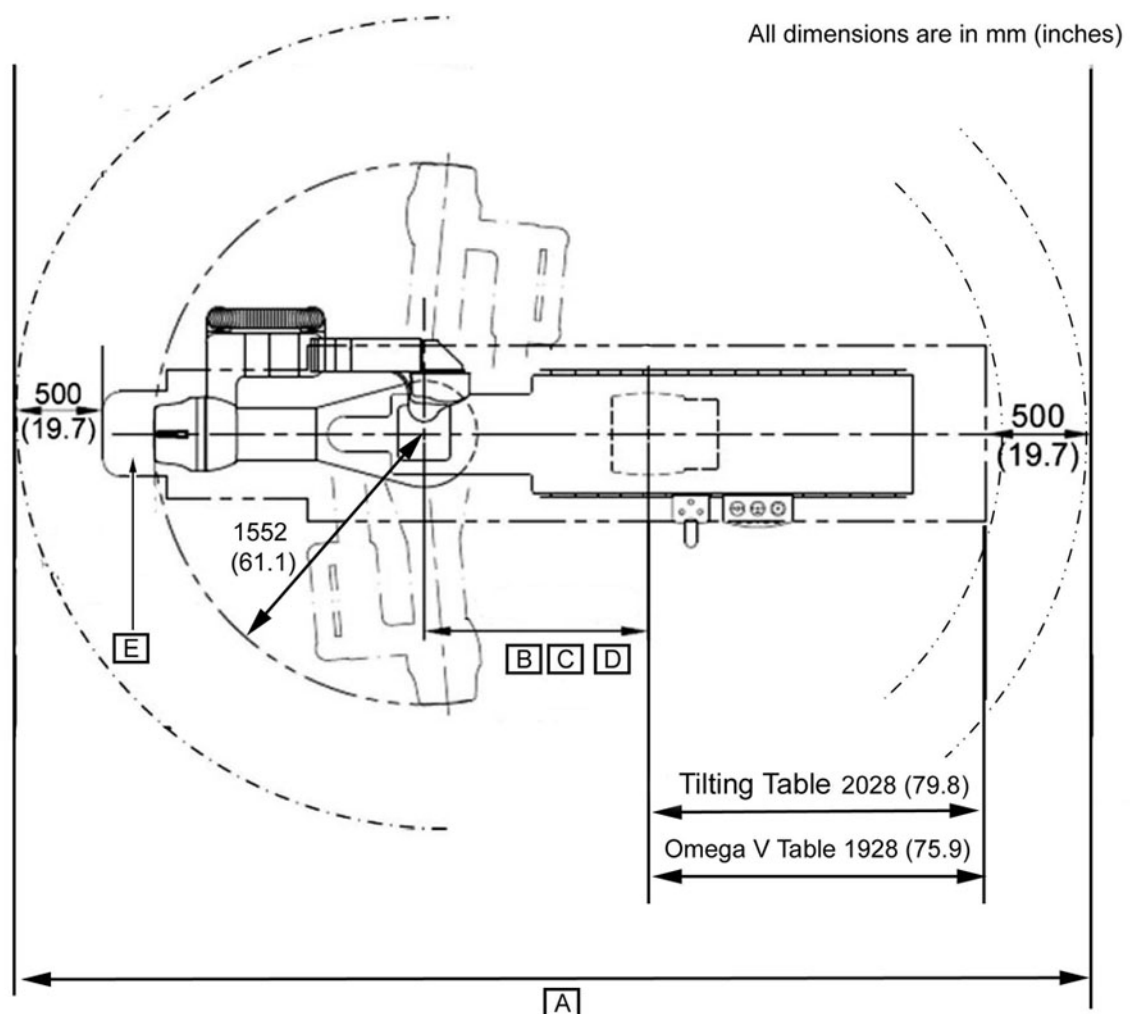
<sup>(1)</sup> Applicable for Cardio 1395 mm (54.9 in).

<sup>(2)</sup> Applicable for both Angio 1278 mm (50.3 in) and Cardio/Neuro 1395 mm (54.9 in).

<sup>(3)</sup> Applicable for both Angio 1278 mm (50.3 in) and Neuro 1395 mm (54.9 in).

For Head Extender Dimensional drawing, refer to [Dimension Drawings](#).

**Figure 71 Minimum Room Length Dimension**



## 2.2.2 Room Layout Drawings

### 2.2.2.1 Exam Room Layout



#### NOTICE

Ensure the air outlet positions in the Exam Room is not close to the monitor suspension carriage or rail.

**(For System with V-Point)** The V-Point wall box should be installed on the wall and at a suitable height (between 0.80 m and 1.20 m (2.6 ft to 3.9 ft)) from the floor. It should be near an electrical distribution such as a cable tray or technical sheath, otherwise provide one to route cables towards the floor or the ceiling. Cable path through the V-Point wall box can be located on one of the four sides of the box or on the back of the box. The routing of the cable shall respect a minimum bending radius of 30 mm.

Legend of [Figure 72 on page 97](#), [Figure 73 on page 98](#), [Figure 74 on page 99](#) [Figure 75 on page 100](#) and [Figure 79 on page 103](#):

1. Gantry
2. Patient Table
3. Monitor suspension
4. Monitor frame
5. Injector on pedestal

### 2.2.2.1.1 Exam Room Layout - Monitor Suspension with rails

Figure 72 Exam Room Layout - Monitor suspensions rails parallel to patient table (to side of table)

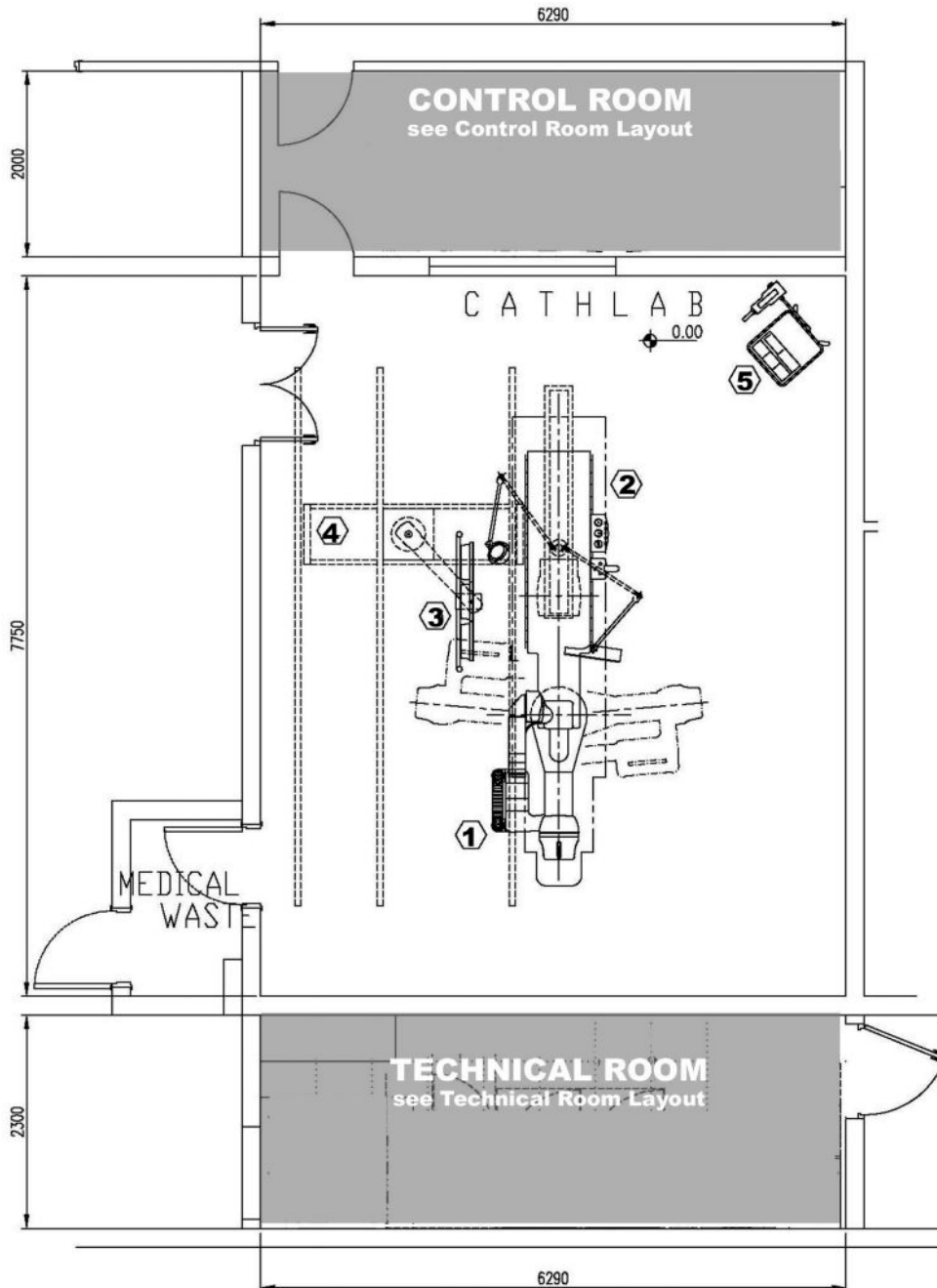
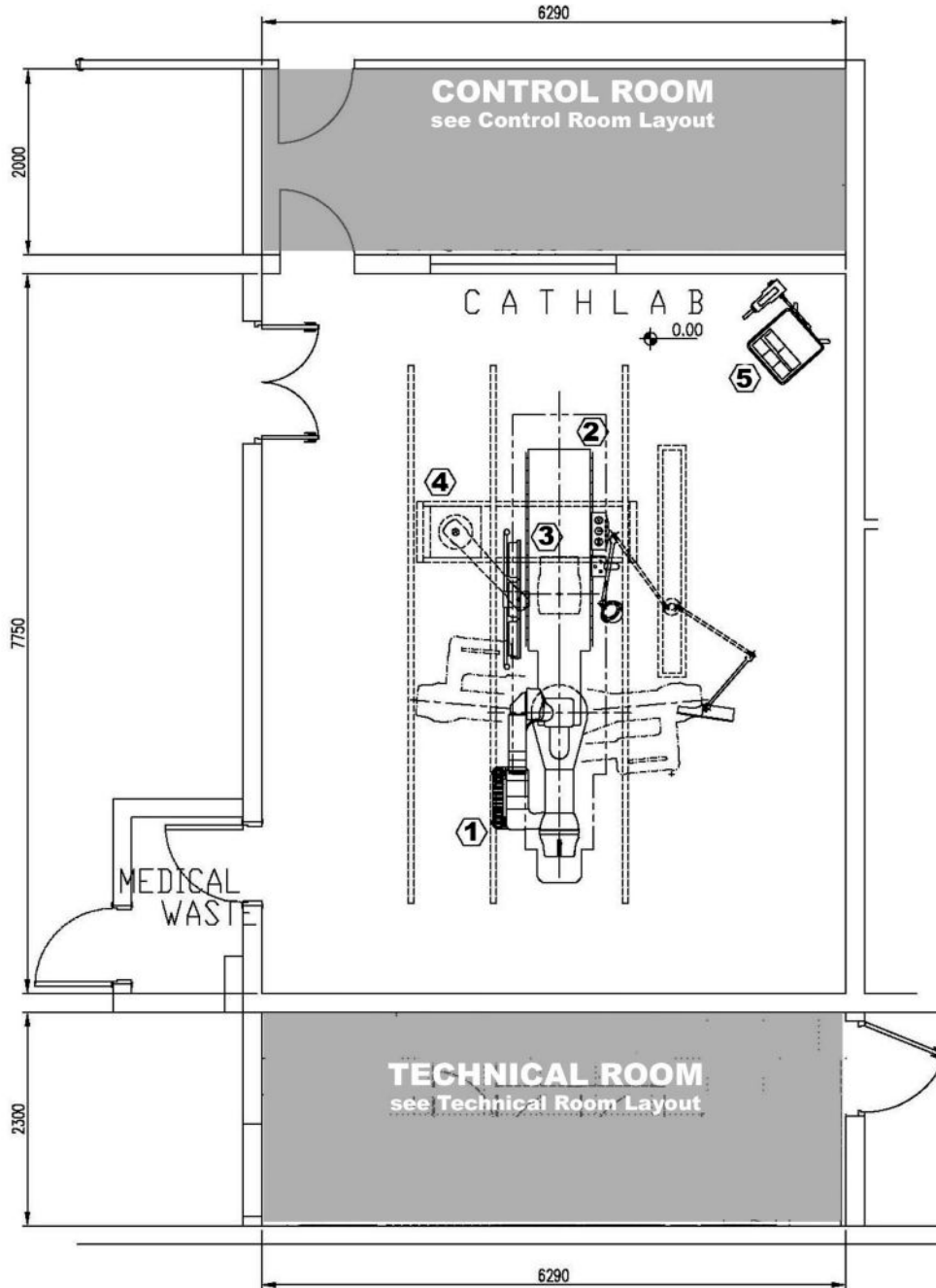
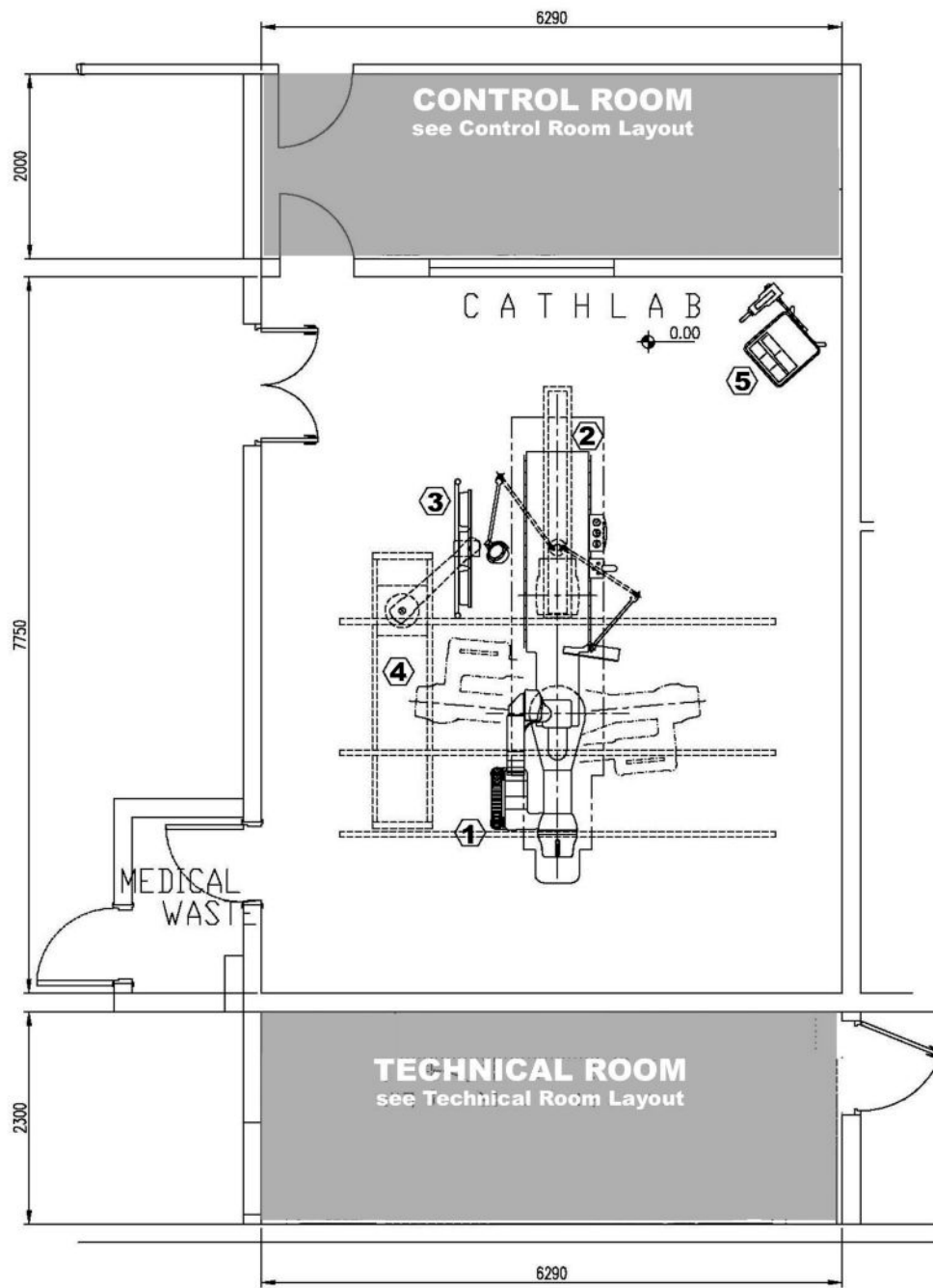


Figure 72 on page 97 is mandatory with hospital having air flow installation.

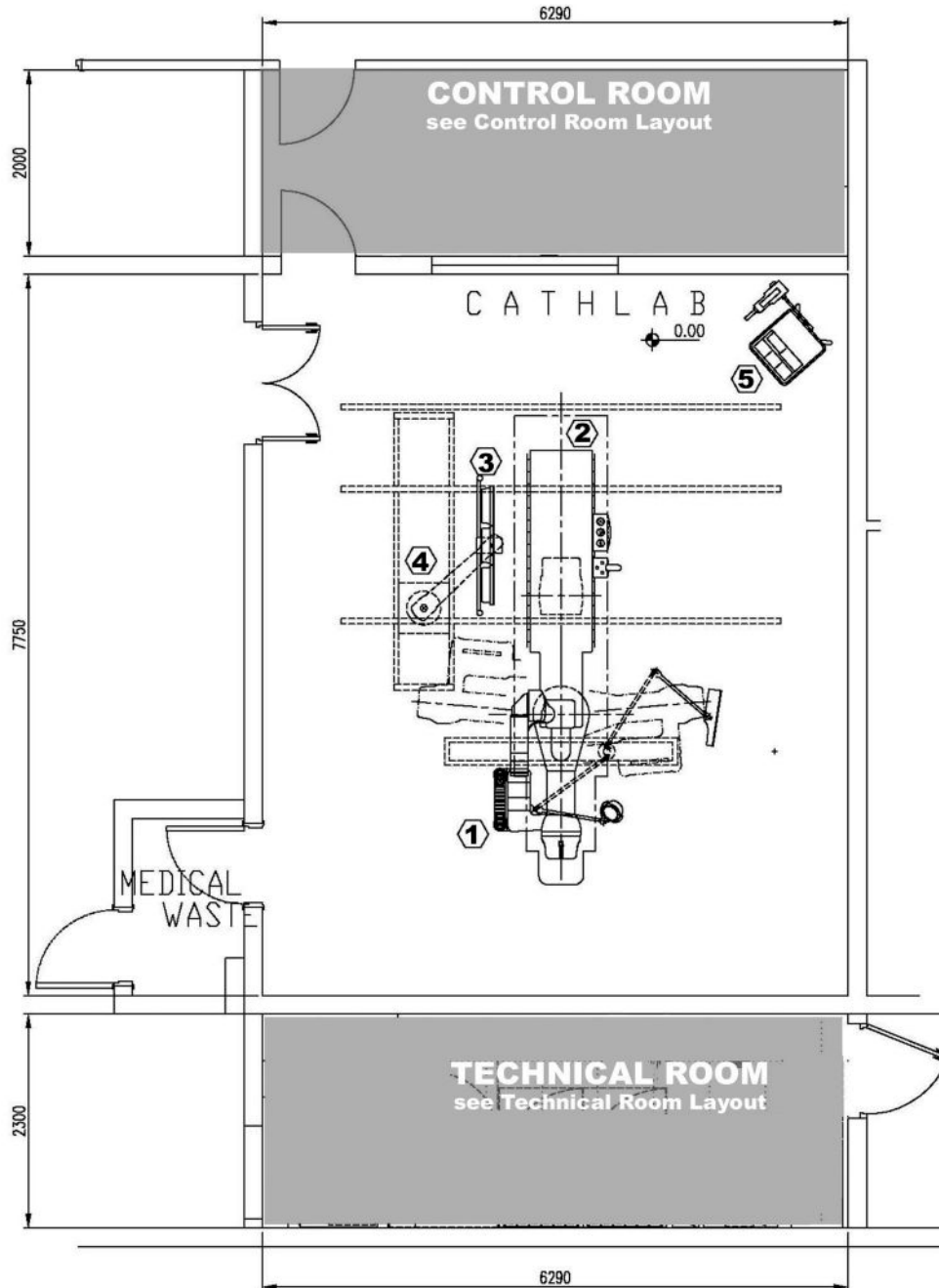
**Figure 73 Exam Room Layout - Monitor suspensions rails parallel to patient table (over table)**



**Figure 74 Exam Room Layout - Monitor suspensions rails perpendicular to patient table (Gantry side)**



**Figure 75 Exam Room Layout - Monitor suspensions rails perpendicular to patient table (table side)**



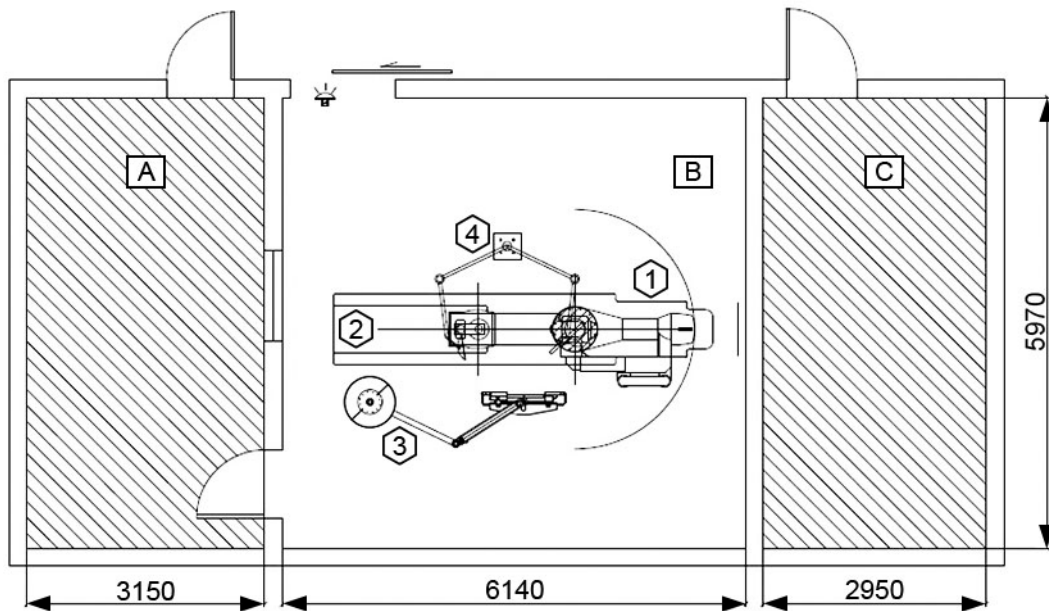
**2.2.2.1.2 Exam Room Layout - Monitor Suspension with fixed point dual arm**

The suspension ceiling fixation shall be determined taking into account at least:

- Clinical need: with an overall radius coverage of 2.21 m for 19" monitor suspension or 2.03 m for Large Display Monitor suspension. Ensure the monitor(s) will be able to reach the position required by medical staff.
- Parking position.

- Ceiling constraints: other component and air flow.
- Cable output and ceiling trap.

**Figure 76 Exam Room Layout - MAVIG suspension with fixed point with dual arm for four 19" monitors**



Item	Description
A	Control Room
B	Exam Room
C	Technical Room
1	Gantry
2	Table
3	4 Monitor Dual Arm Suspension
4	X-ray Rad Shield

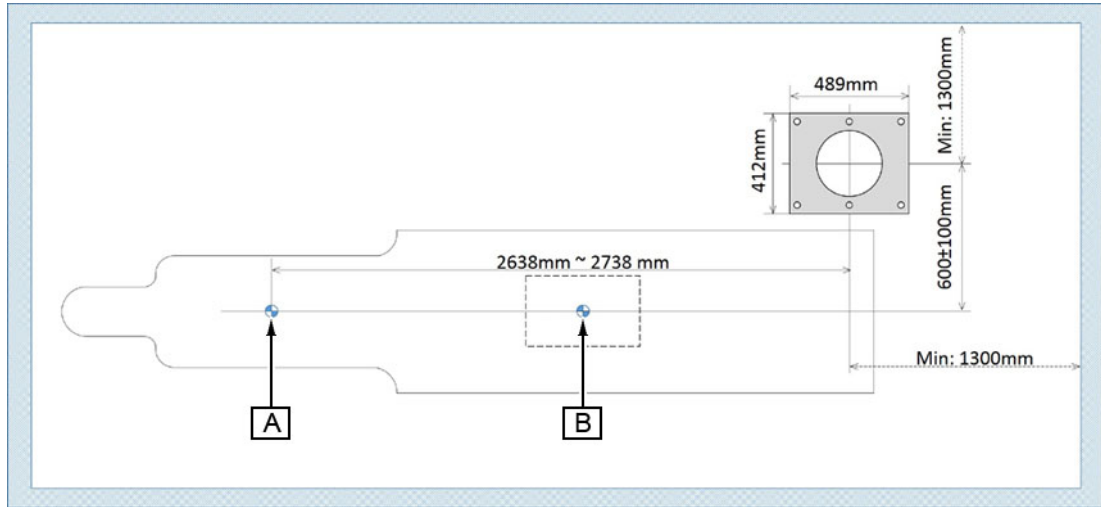
The recommended position for the sub-structure ceiling plate installation as in below drawings:

- If the typical procedure of customer is on the patient right, the recommend position refer to [Figure 77 on page 102](#).
- If the typical procedure of customer is on the patient left, the recommend position refer to [Figure 78 on page 102](#).

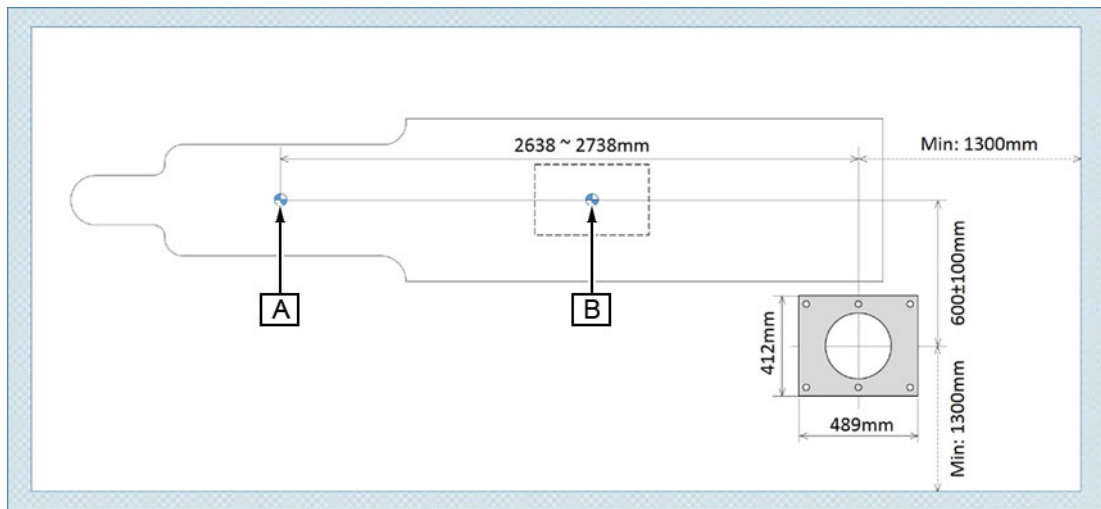
**NOTE**

The longitude edge of the ceiling plate should be parallel to the table top longitude axis. The distance from center of substructure to the wall should be at least 1300 mm as in the drawing, otherwise, suspension arm could not be rotated full range.

**Figure 77**

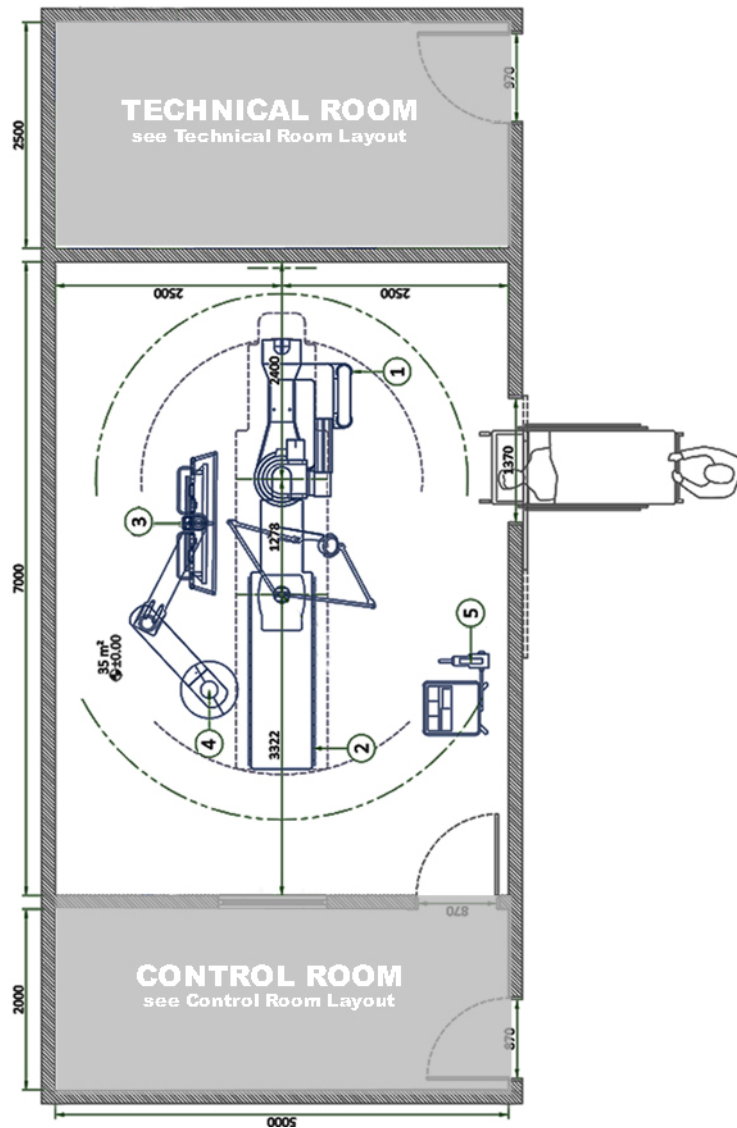


**Figure 78**



Item (Figure 77 on page 102 and Figure 78 on page 102)	Description
A	ISO Center
B	Table Center

**Figure 79 Exam Room Layout - MAVIG suspension with fixed point with dual arm for Large Display Monitor**



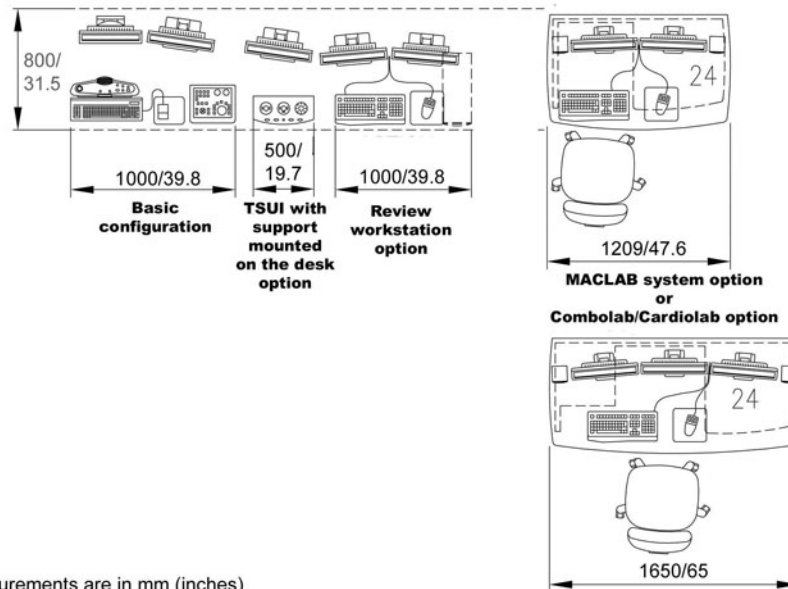
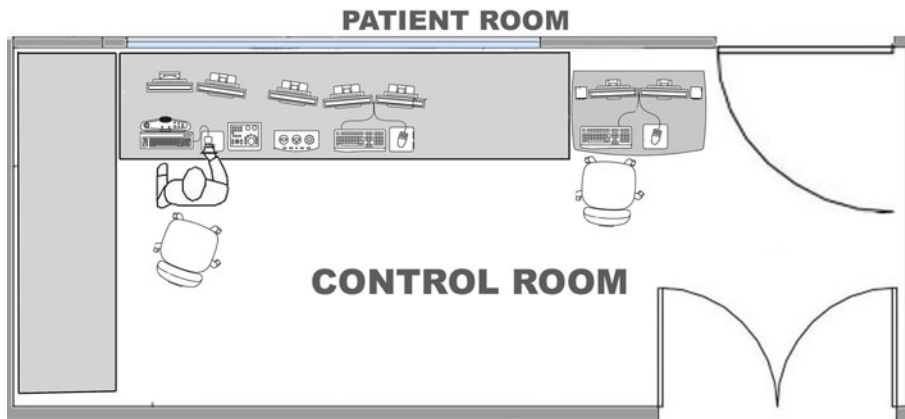
### 2.2.2.2 Control Room Layout

Motion controls installed in remote location from the Table shall be installed at a location where all the positioner axis are visible by the operator.

**(For System with Innova<sup>IQ</sup> Table)** The remote motion controls shall not be installed on the longitudinal axis of the Table (to avoid any operator visual dead angle due to tilted table top hiding the patient).

**(For System with V-Point)** The V-Point wall box should be installed on the wall and at a suitable height (between 0.80 m and 1.20 m (2.6 ft to 3.9 ft)) from the floor. It should be near an electrical distribution such as a cable tray or technical sheath, otherwise provide one to route cables towards the floor or the ceiling. Cable path trough the V-Point wall box can be located on one of the four sides of the box or on the back of the box. The routing of the cable shall respect a minimum bending radius of 30 mm.

**Figure 80 Control Room Layout**



All measurements are in mm (inches)

### 2.2.2.3 Technical Room Layout



**NOTICE**

CONDENSATION MAY OCCUR ON THE OUTLETS AND PIPES OF THE AIR CONDITIONING SYSTEM, THEREFORE, IT IS CRITICAL TO INSTALL THE CABINETS WHERE THERE IS NO RISK OF WATER DROPS FROM THE AIR CONDITIONER.

#### 2.2.2.3.1 General Requirements

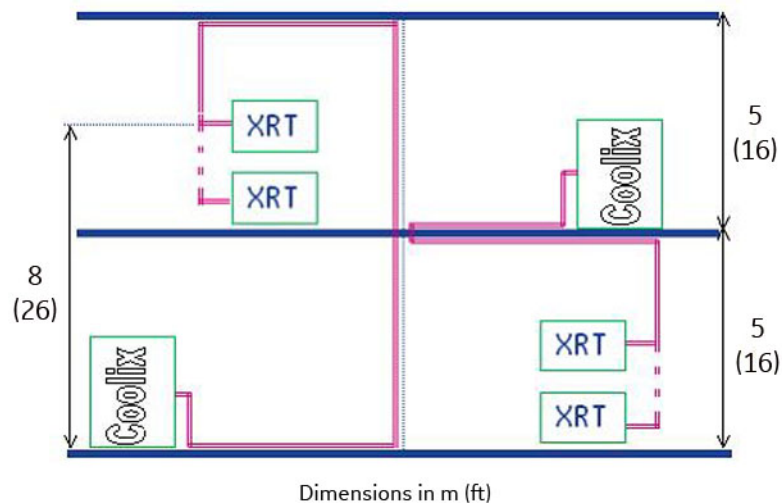
It is not allowed to store objects on cabinet top, or to stack cabinets one on another.

In cases 2 cabinets are installed face to face (both sides of the access way), the clearance width shall be at least 1.2 m.

In order to maintain their cooling capacities:

- The Tube Chiller shall be no more than 5 m (16 feet) above or 8 m (26 feet) below the upper position of the X-Ray Tube.

**Figure 81 Distance between Tube Chiller and X-Ray Tube**



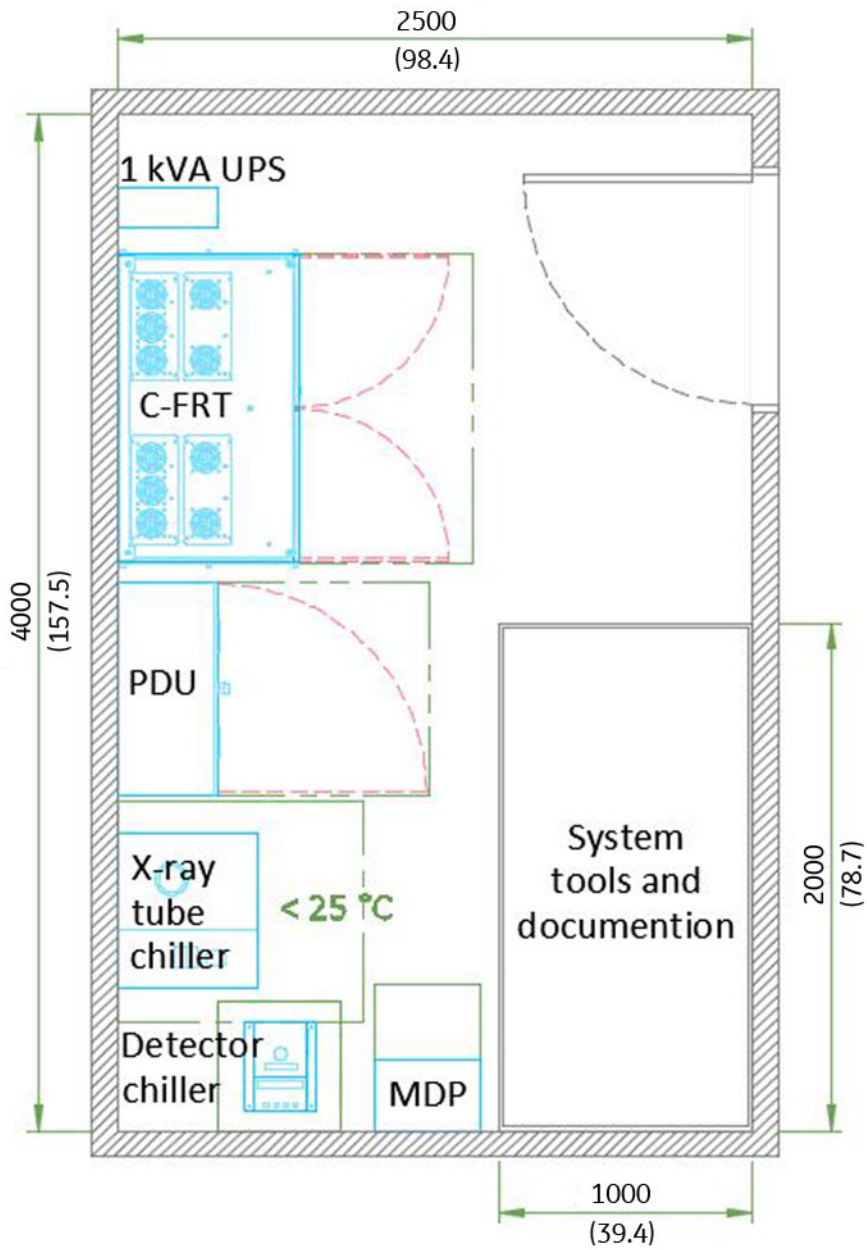
**NOTE**

The highest point of the water network can be 10 m (32 feet) above the floor of the Technical Room where the Coolix-4100 is located (case where the Technical Room is one floor under the Exam Room).

- The Detector Conditioner shall be no more than 3 m in height below the Detector.

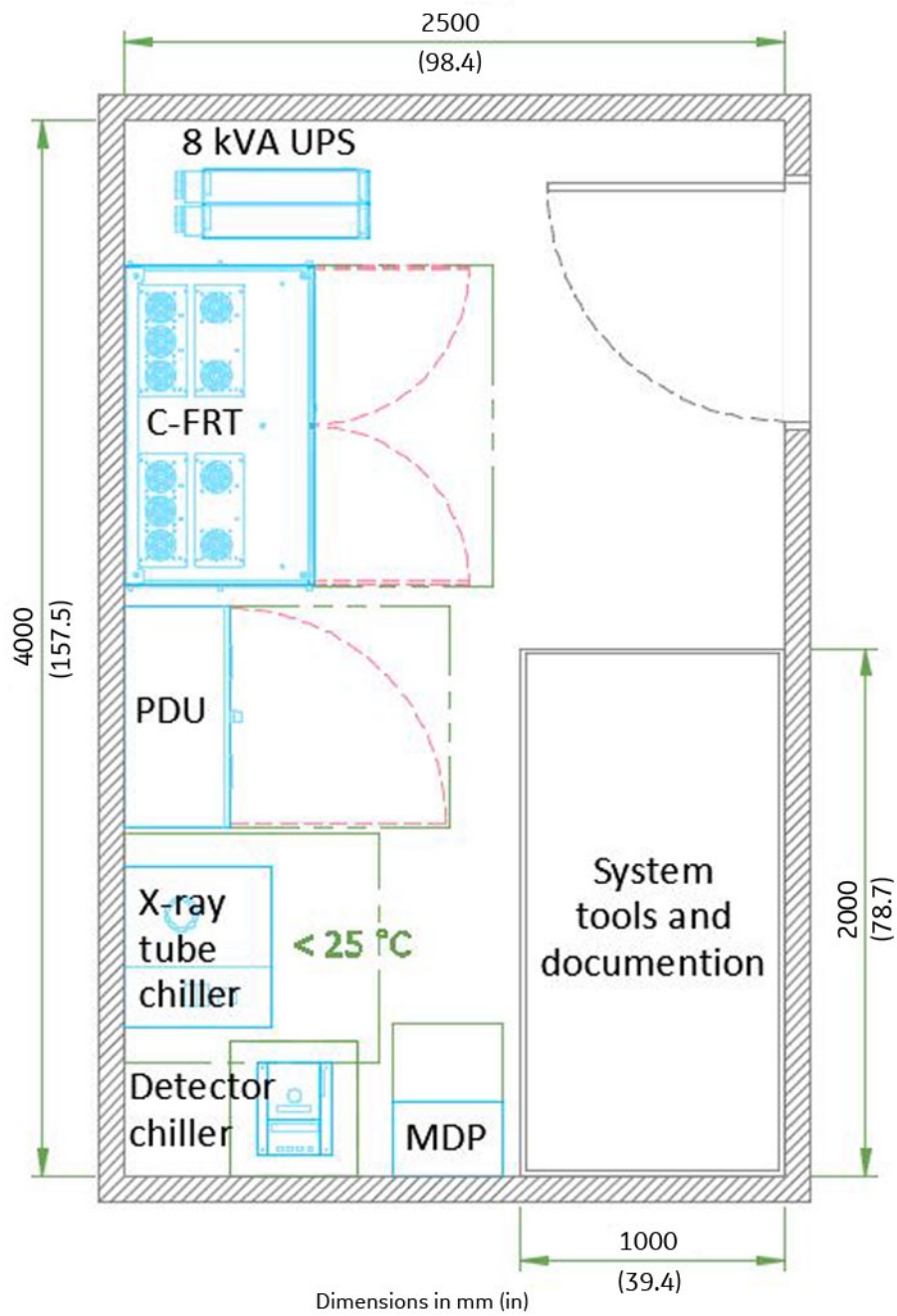
It is the customer responsibility to install a fire extinguisher (non-water type, ex. CO<sub>2</sub>) close to the Fluoro UPS CE Cabinet.

Figure 82 Technical Room Layout - Configuration 1 kVA UPS

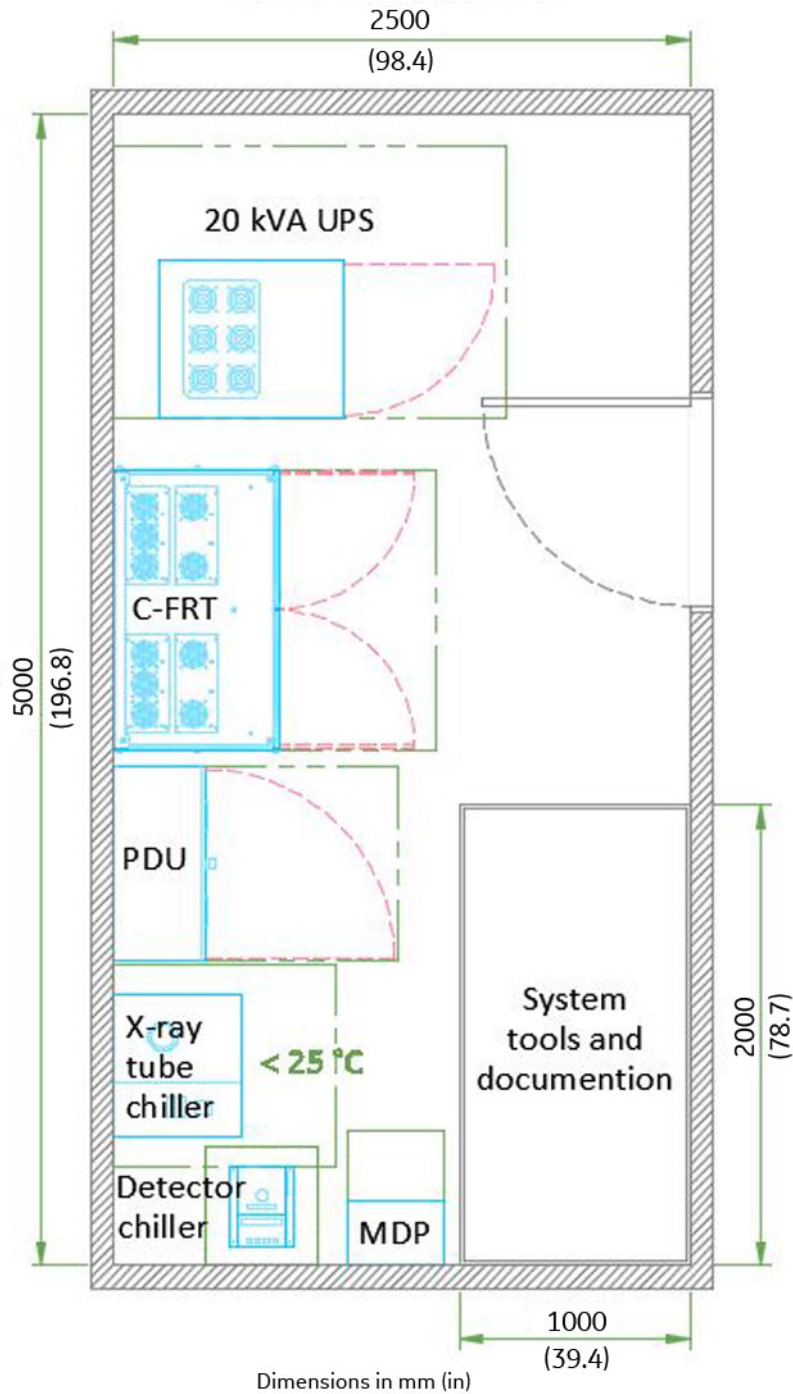


Dimensions in mm (in)

**Figure 83 Technical Room Layout - Configuration 8 kVA UPS**



**Figure 84 Technical Room Layout - Configuration 20 kVA UPS (Fluoro UPS)**



### 2.2.2.3.2 Requirements for Equipment Airflow

If the Technical Room is in a dusty environment, it is strongly recommended to install filters on the air inlet of the Technical Room. These filters can cause reduced speed at the air inlet, and the size of the air inlet has therefore to be dimensioned accordingly

The following distances shall be respected to guarantee proper cooling air exhaust.

**C-FRT Cabinet:**

- The minimum clearance between the ceiling and the top of the C-FRT Cabinet is 30 cm (11.8 in).

**NPA PDU:**

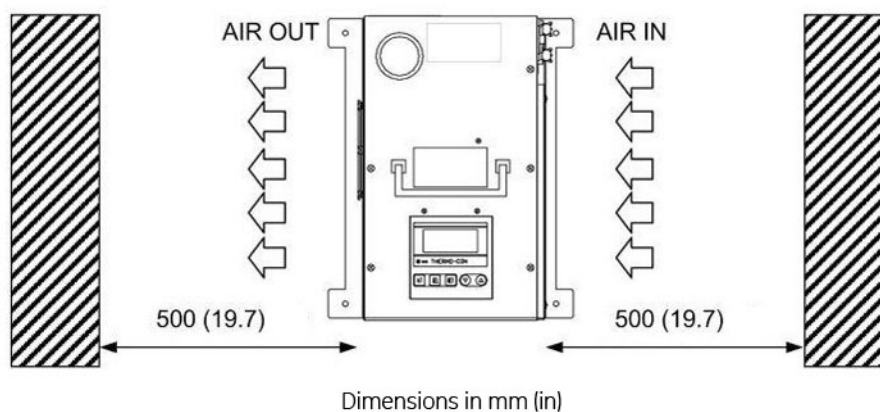
- The minimum clearance between the ceiling and the top of the NPA PDU is 30 cm (11.8 in).

**Tube Chiller:**

- The Chiller can operate normally when installed against a wall or another cabinet (no possible air flow) on 1 side. The following clearance must be respected: back and one side: 40 cm minimum, front: 13 cm.

**Detector Conditioner:**

- The following 50 cm clearance on the sides must be respected.

**Figure 85 Detector Conditioner – Minimum clearance****Fluoro UPS:**

- Make sure there is a ventilation air flow, preferably ensured by natural air flow, otherwise by enforced ventilation, so that hydrogen concentration is below 1% (according to the Standard IEC 62040-1-2).
- The minimum clearance between the ceiling and the top of the UPS is 40 cm.
- UL version: the left, right or back side of the UPS can be positioned against the wall or another cabinet.
- CE version: a clearance of 20 cm between the UPS back and the wall must be respected.

**2.2.2.3.3 Requirements for Service Access**

A free area in front of the following cabinets shall allow to open fully their doors for service access:

- PDU
- C-FRT Cabinet
- MDP
- Fluoro UPS

**C-FRT Cabinet:**

## Equipment Requirements

- A clearance of 80 mm on the lateral sides of the C-FRT Cabinet. It allows the installation of the anchoring brackets and the full opening of the doors for service access

### Tube Chiller:

- Minimum 40 cm is recommended for servicing on the left and right side panel. The right side panel is the main side for maintenance. It is recommended to leave this side accessible. The chiller is equipped with wheels that allow to move it during maintenance to allow access on both sides

### Fluoro UPS:

- CE version: A clearance of 50 cm is needed on the right side of the UPS for service.

## 2.2.2.4 ECG Device Room Configurations

The ECG connection is compatible with an ECG device in the Control Room or in the Exam Room.

The Analog Output Box option is mandatory to provide an analog output connection to the Physio module (If not present, it can be ordered through the following FRUs):

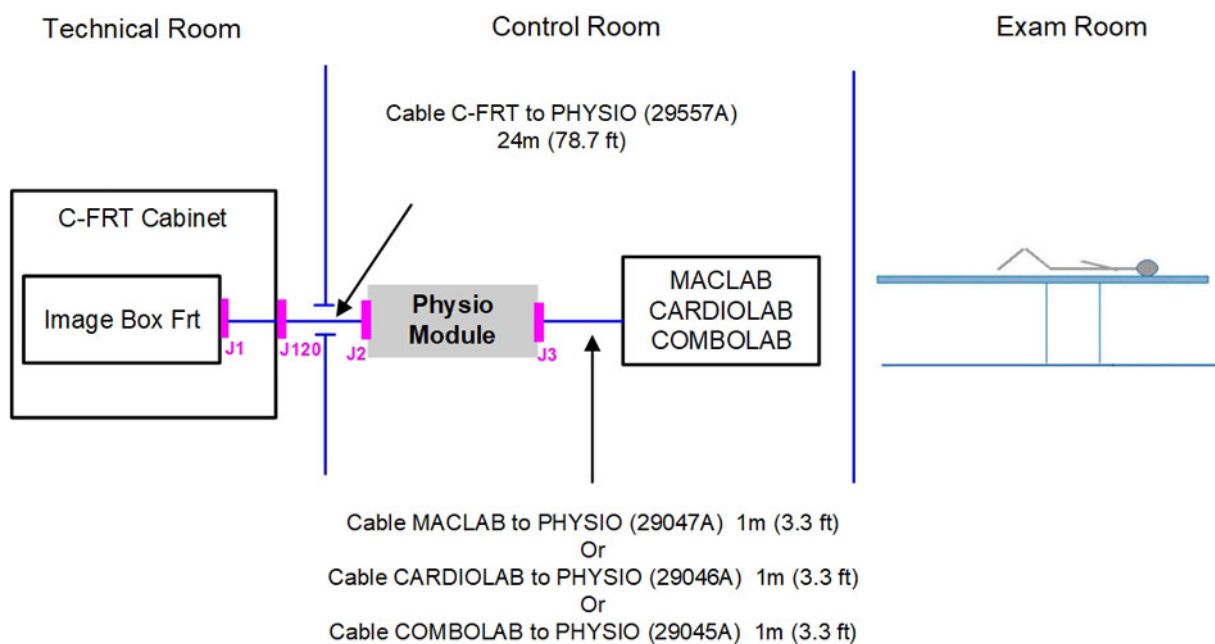
- 2018971-001 16CH ANALOG OUTPUT CPU INTERFACE OPTION
- 2007557-002 KIT ANALOG OUTPUT BOX W/CABLES
- 2010476-001 BOX CARDIOLAB/MACLAB ANALOG OUTPUT

### 2.2.2.4.1 ECG device in Control Room

Applicable to GE ECG device as MacLab, CardioLab or ComboLab.

In this configuration, the Physio module is installed in the Control Room.

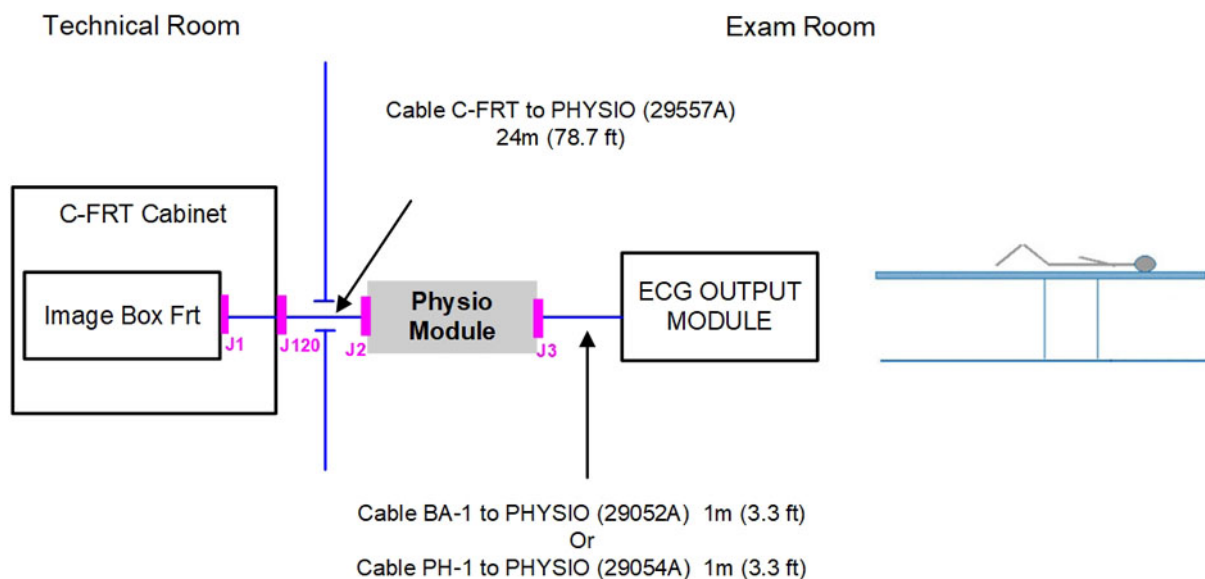
**Figure 86 ECG device in Control Room - Connection**



### 2.2.2.4.2 ECG device in Exam Room

In this configuration, the Physio module is in the Exam Room.

**Figure 87 ECG device in Exam Room - Connection**



## 2.2.3 Room Layout Considerations

### 2.2.3.1 Radiation Protection

Because X-Ray equipment produces radiation, you may need to take special precautions or make special site modifications. The General Electric Company does not make recommendations regarding radiation protection. It is the purchasers' responsibility to consult a radiation physicist for advise on radiation protection in x-ray rooms.

### 2.2.3.2 Clinical Access

Make sure that you plan the room with the following clinical access requirements:

- Provide easy access to the patient table. Stretchers and other mobile hospital equipment must reach the table quickly.
- Gantry installation shall make a provision so that the clearance is 500 mm (19.7 in) around the gantry.
- The layout of the table in the room (refer to section Room Layout Drawings in the System PIM) shall make a provision so that the clearance between:
  - the maximum table position (head side) on system axis and any object in the room (e.g.: wall, device) is greater than 500 mm (19.7 in) or 700 mm (27.6 in) if the Header Extender is used, taking into account the fact that the table can rotate 180°.
  - the maximum table position (foot end side) on system axis and any object in the room (e.g.: wall, device) is greater than 500 mm (19.7 in), taking into account the fact that the table can rotate 180°.

- Provide sufficient space around the patient table for the unimpeded conduct of CPR (Cardiac Pulmonary Resuscitation). With the table in this position, the table must be capable of rotating  $\pm 45^\circ$
- Clinicians at the patient table must be able to communicate with assistants in the control area.
- There must be an unrestricted view of the video monitors and physiological monitoring equipment from the vascular table. Refer to the section Equipment Requirements in the System Pre-Installation Manual.
- Operators in the control area must have easy access to the control console. However, position the controls (including handswitches) so that the operator cannot take exposures while looking around or standing outside the control booth's lead glass window.
- Operators in the control area must have easy access to video recorders, injector programmers, and service and operating manuals.
- Consult customer on the number and location of nonelectrical lines (air, oxygen, vacuum, water, etc.) in the vascular room.
- For systems with the LDM, make sure the backup monitors are easily accessible to view in case of failure of the LDM. For the systems where the backup monitors are mounted at the back of the LDM, plan a clearance so that the monitor can be flipped at  $180^\circ$ .

### **2.2.3.3 Peripheral Equipment**

Consult hospital personnel regarding additional space requirements for the following types of hospital equipment:

- Sinks
- Oxygen stations
- IV apparatus
- Injectors
- Heart monitoring equipment
- Crash cart
- Ultrasound equipment.

### **2.2.3.4 Patient Environment Equipment**

As defined in the IEC60601-1, the patient vicinity is defined as the space within the room 1.83 m (70.7") beyond the perimeter of the table and extending vertically 2.29 m (90.2") above the floor. Only the following components of the system can be installed within the patient vicinity:

- Table and its accessories
- Monitors
- Injector
- Rad-Shield
- Table Side User Interfaces
- In-room AW mouse.

## 2.3 Room Structural Requirements

### 2.3.1 General Policy

#### 2.3.1.1 Baseplates Mounting

GE Healthcare's Customer is responsible for the structural analysis and mounting of the base plates. If GE Healthcare is forced to mount the base plate, the LCT must hire a structural engineer to design and approve the mounting method and provide GE Healthcare with an engineering report.

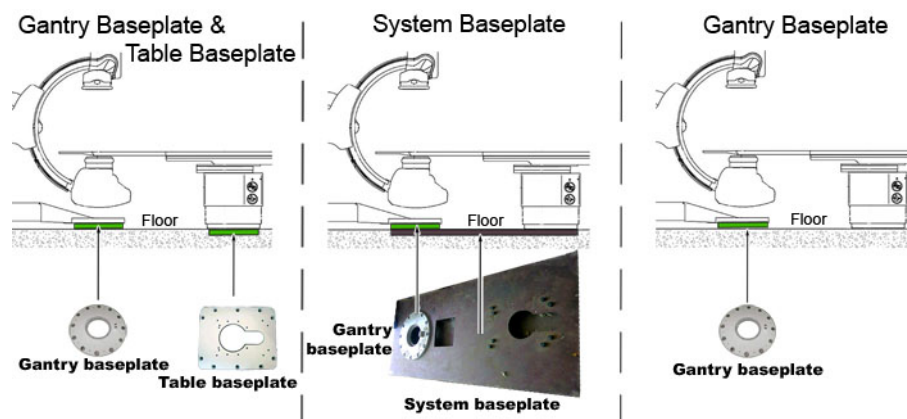
The floor level cannot exceed a general levelness of 5 mm (0.2 in) for any 2 meters (79 in).



#### NOTICE

The floor slabs on which the equipment is to be installed must have a levelness of 1 mm (0.04 in) per meter (40 in). Position of baseplates and table basement depends on the type of installation. The two types of installation are given below.

**Figure 88 Types of baseplate installation**



#### NOTICE

The Table baseplate or the System baseplate are mandatory to install the Innova<sup>IQ</sup> Table.

The Innova<sup>IQ</sup> Table must never be installed on grade.



**NOTICE**

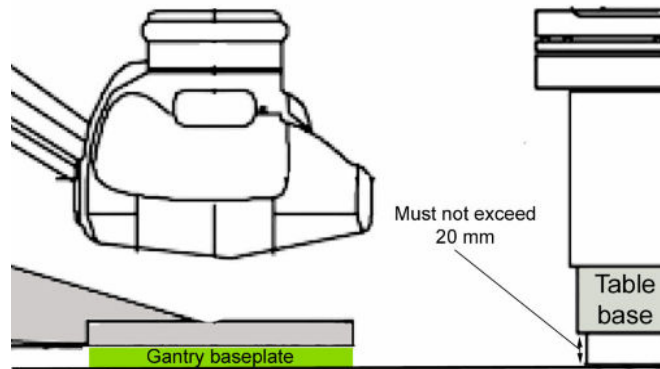
Augmented Calibration requires that the patient table and gantry be installed following Pre-installation instructions. Any deviation result in errors raised during calibration.



**NOTICE**

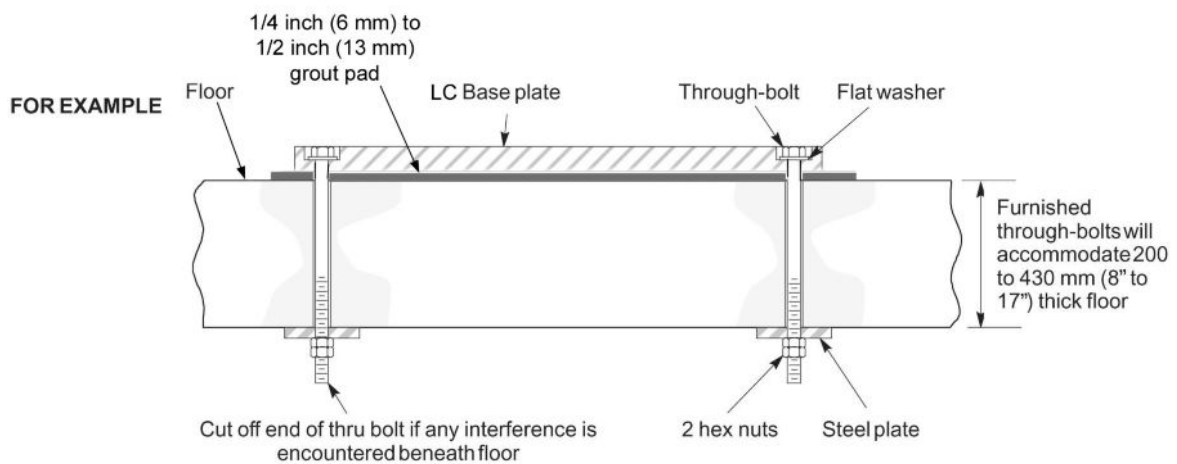
The gap between the Table Foot bottom end the Gantry Baseplate bottom end shall be lower than 20 mm (0.97 in). Any bigger gap would make the system incompatible with the Innova Vision Applications.

- Gap between Table Foot bottom end the Gantry Baseplate bottom



The preferred installation method for the Innova LC Positioner or the Omega tables is through-bolting. The through-bolting method can be used in all seismic zones. If through-bolting cannot be used, use provided floor anchors instead.

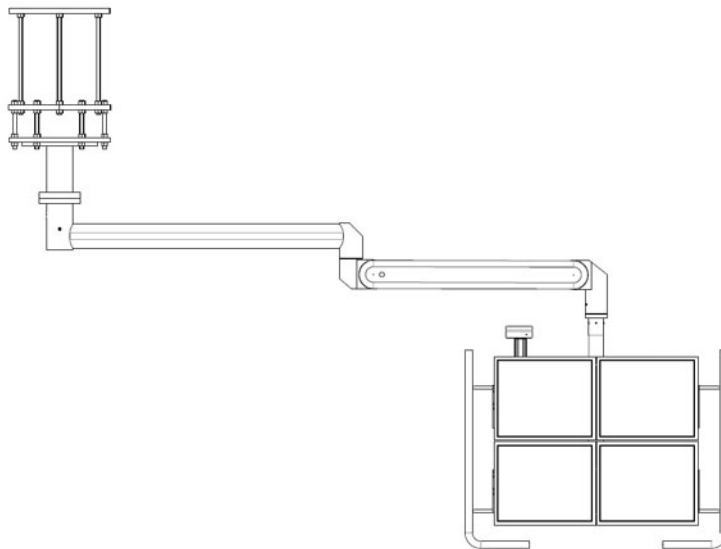
**Figure 89 Through-Bolt Supplied (Slab Type Floor Construction)**



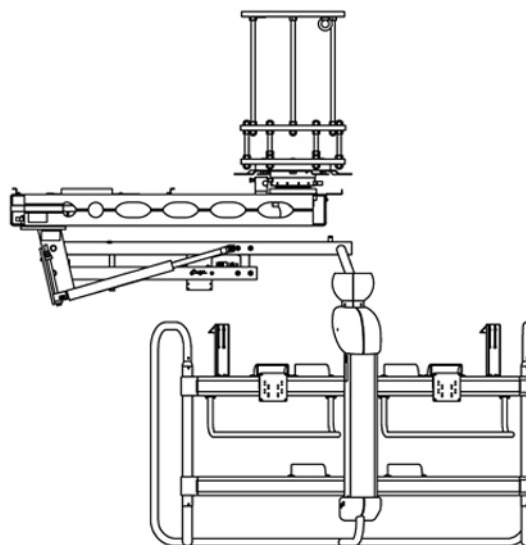
### 2.3.1.2 Substructure for Dual Arm suspension Mounting (for Mavig suspension with fixed point dual arm)

The customer is responsible for the structural analysis and mounting of the Substructure for Dual Arm suspension in the solid ceiling (in case of a MAVIG suspension with fixed point dual arm). If customer requires GEHC to mount the Substructure for Dual Arm suspension, the customer must hire a structural engineer to design and approve the mounting method and provide GEHC with an engineering report.

**Figure 90 Medium Height Substructure for Dual Arm Suspension and MAVIG Suspension with Fixed Point Dual Arm for four 19" Monitors**



**Figure 91 Medium Height Substructure for Dual Arm Suspension and MAVIG Suspension with Fixed Point Dual Arm for Large Display Monitor**





**NOTICE**

The Substructure for Dual Arm suspension is mandatory to install the MAVIG suspension with fixed point dual arm.



**NOTICE**

The lower edge of the Substructure for Dual Arm suspension should be the same height as the lower edge of the false ceiling.

## 2.3.2 Floor Requirements

### 2.3.2.1 Floor requirements when using provided floor anchors

The maximum pullout force per provided anchor was calculated assuming:

- A concrete compression strength of **17.24 MPa** at 28 days (which is the minimum required compression strength).
- Anchors installed to the required hole depth of **165.1 mm** minimum, and
- Center of anchor hole to concrete edge distance **79.4 mm**.

Make sure to obtain data on compression strength of the concrete before using floor anchors.

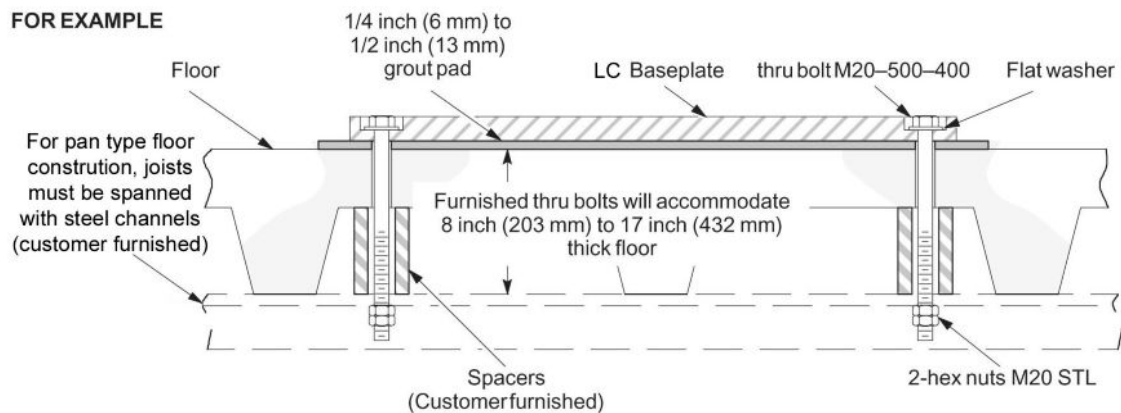
### 2.3.2.2 Pan Type Floor Construction Requirement

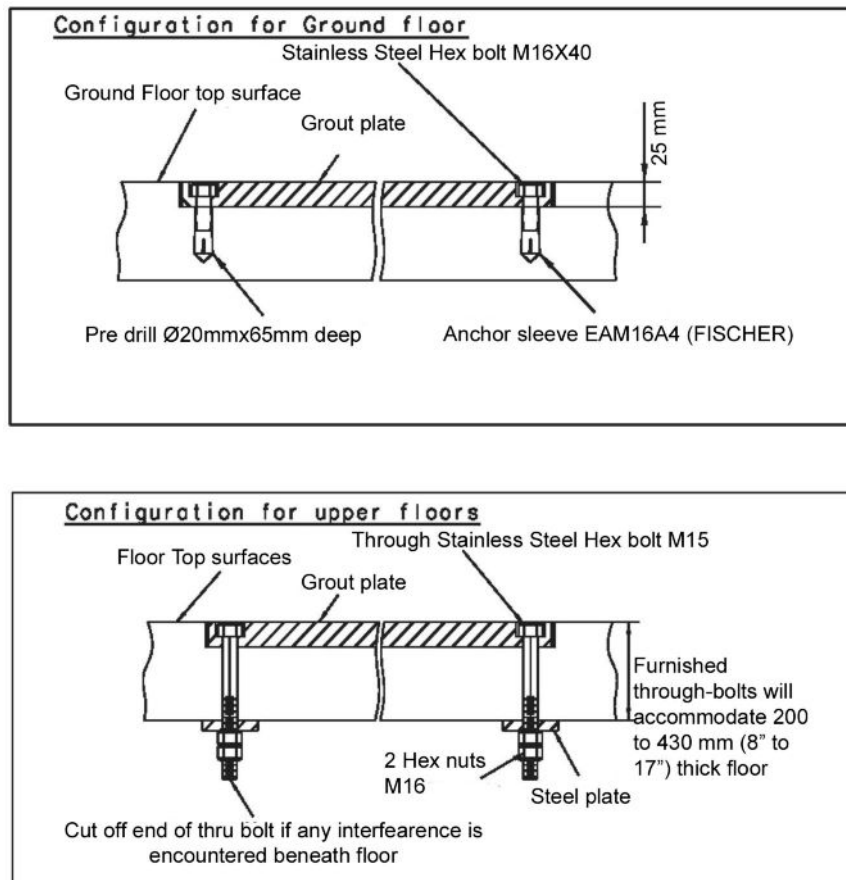
For Pan type floor construction, steel channels must be designed by a local structural engineer to span floor joists. See [Figure 92 on page 116](#).

**NOTE**

For specific floor preparation procedures, refer to *Pre-Installation Kit Installation Procedures*.

**Figure 92 Through-Bolt Supplied (Pan Type Floor Construction)**



**Figure 93 Table floor mounting layout****NOTICE**

Prepare the floor such that the table base plate will be flush with the floor finish surface, taking into account the thickness of the floor finish material.

For alternative table bolts or seismic area, refer to template drawing shown in Illustration *Innova LC Positioner And Table Floor Mounting Template* contained in [Mounting Requirements](#).

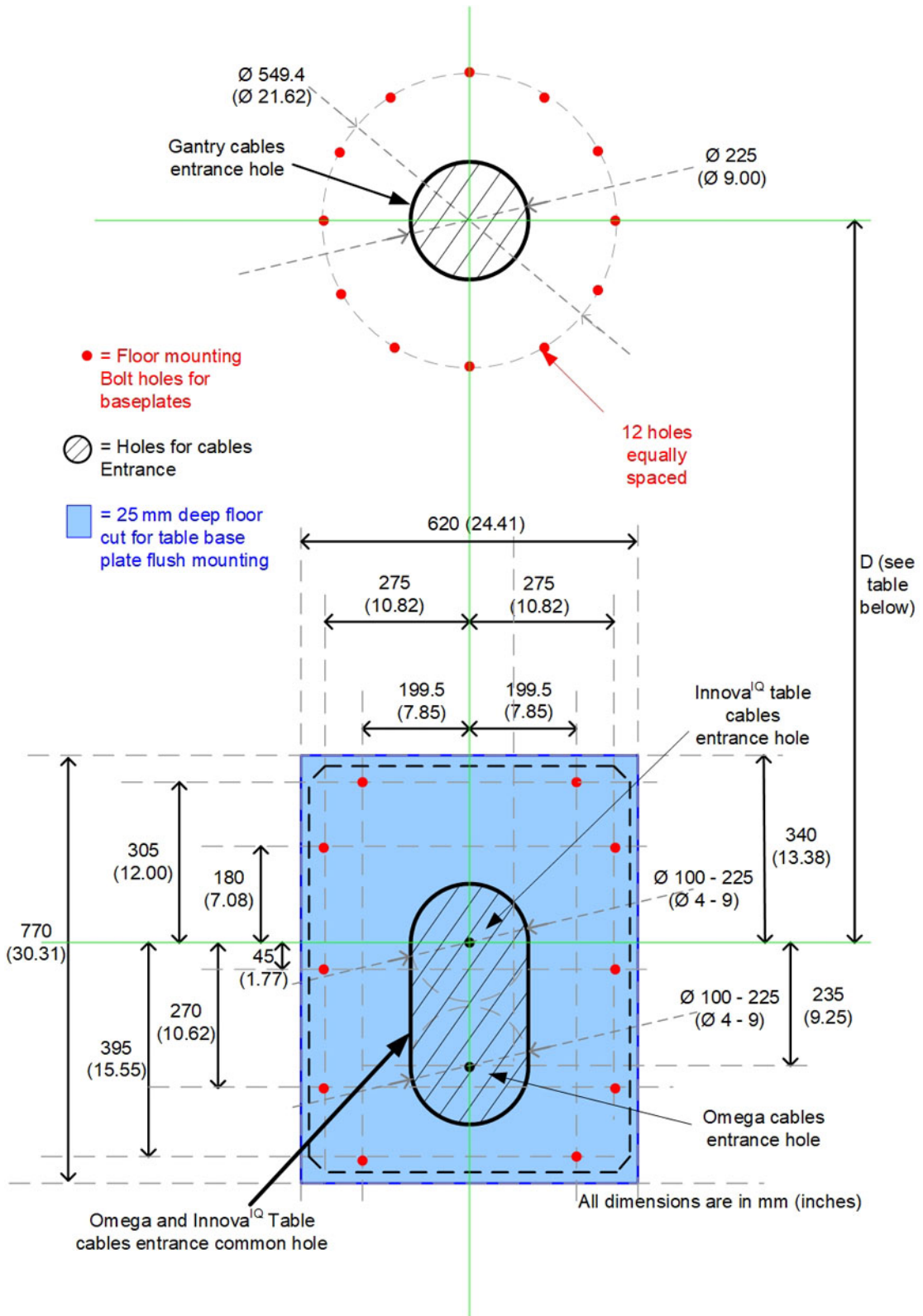
### 2.3.2.3 Hole dimension and preferred location in concrete floor

In the Exam Room, the Innova LC Positioner is not placed on a computer floor but directly put on concrete floor, the location of the cable access needs to be carefully planned.

Otherwise, if the cable run is located under the concrete floor, the cables will have to come through the floor and in this case you will need two holes, one for the LC Positioner and the other for the patient table.

The diameter of both holes is specified in [Figure 94 on page 118](#).

**Figure 94 Hole location in concrete floor**



**Table 18 D distance**

	<b>ANGIO mm (in)</b>	<b>CARDIO mm (in)</b>	<b>NEURO mm (in)</b>
Omega IV Compact Table	Not applicable	1395 (54.9)	Not applicable
Omega V Long Table	1278 (50.3)	1395 (54.9)	1395 (54,9)
Innova <sup>IQ</sup> Table	1278 (50.3)	1395 (54.9)	Not applicable

**NOTICE**

Due to the plastic bushing used in the USA to protect cables from the sharp edges of conduits it is necessary to place the cable conduit inside the table cable access opening but the height of the outgoing conduit plus bushing is limited to 1/2 in (12.7 mm).

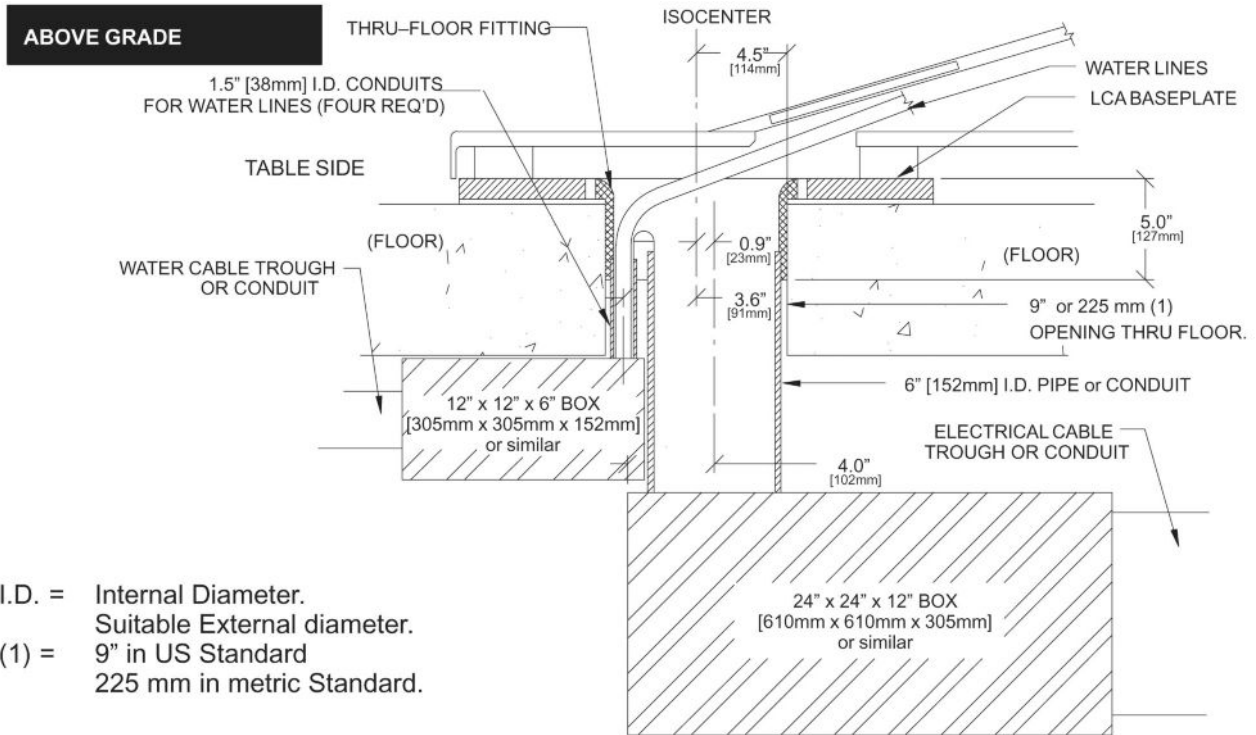
**NOTE**

Refer to table *Chemical anchors Pull out efforts and recommendations* in [Mounting Requirements](#) for pull out effort on each fixation bolts.

**2.3.2.4 Water Pipe Requirements**

The system uses 4 water pipes for the cooling of the Tube and the Detector. Local regulation may require that electrical cables and water pipes are ran in separate conduits from the Chillers to the Gantry.

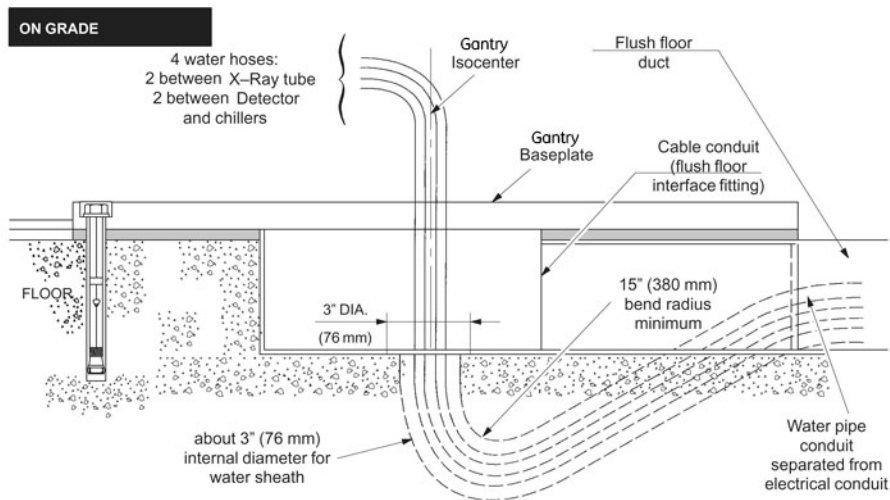
**Figure 95 Water Conduit location with “Above Grade” anchor kits**



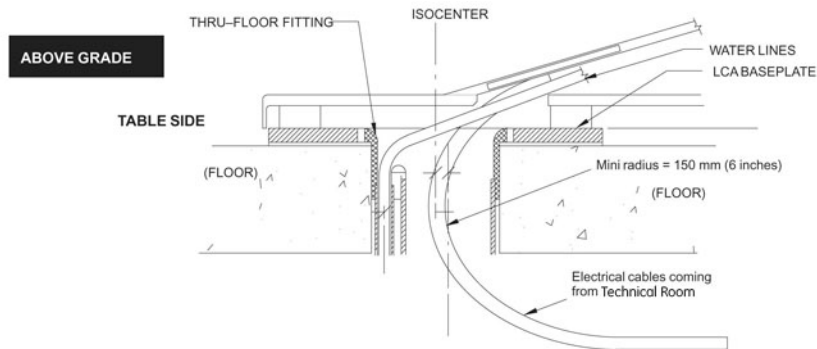
I.D. = Internal Diameter.  
 Suitable External diameter.  
 (1) = 9" in US Standard  
 225 mm in metric Standard.

**Note:** Pipe, junction box and duct or conduit are to be supplied and installed by Customer or customer's Contractor.

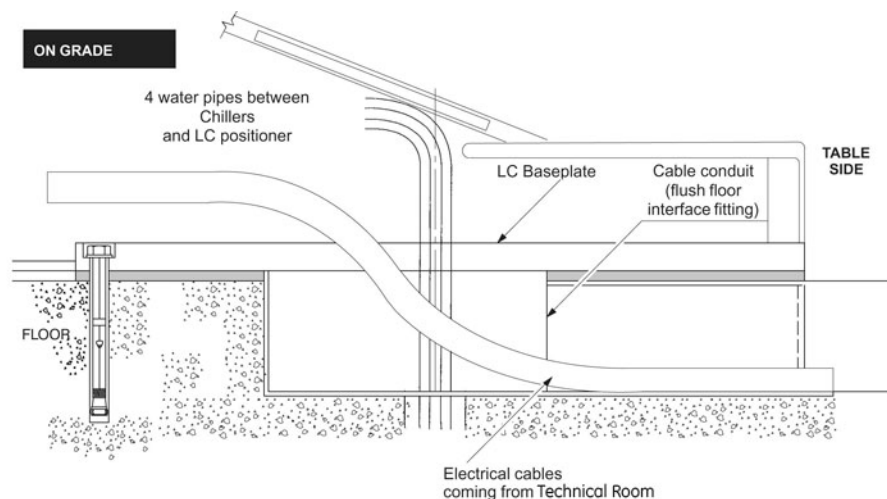
**Figure 96 Water Conduit location with “On Grade” anchor kits**



**Note:** Flush floor interface fitting is part of GEMS installation kit 2286398 and is installed by Customer or customer's Contractor.

**Figure 97 Cable Curvature with “Above Grade” anchor kits**

**Note:** In case of thru-floor cabling, if the electrical cables are coming from the head side, they will need to have a minimum curvature with a minimum radius of 150 mm (6").  
**In any other cases (i.e. flush floor) no such curvature is allowed.**

**Figure 98 Cable Curvature with “On Grade” anchor kits****NOTE**

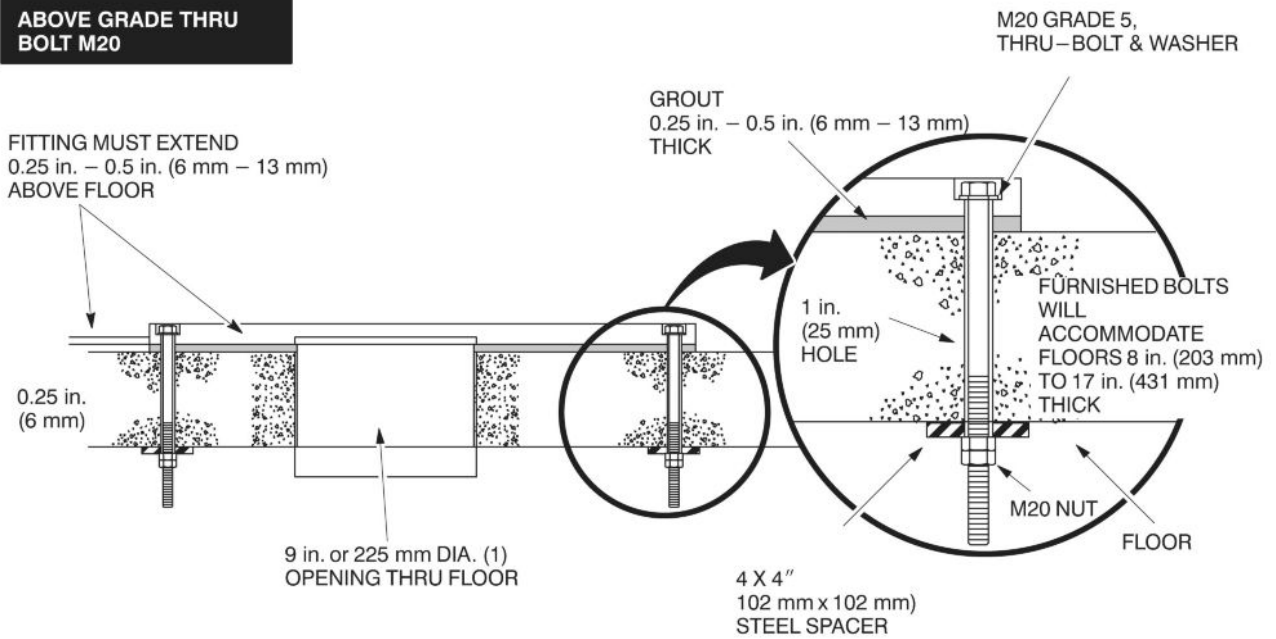
In case of on grade cabling, because of the minimum curvature constraint of 150 mm (6"), the cable will have to come from the side between the Gantry and the Patient Table.

**2.3.3 Mounting Requirements****2.3.3.1 Positioner and Table Floor Mounting**

The distances between the Gantry and the Tables are critical for a proper clinical usage. For this reason, GEMS provides two floor mounting templates to ensure these components are properly placed in relation to one another.

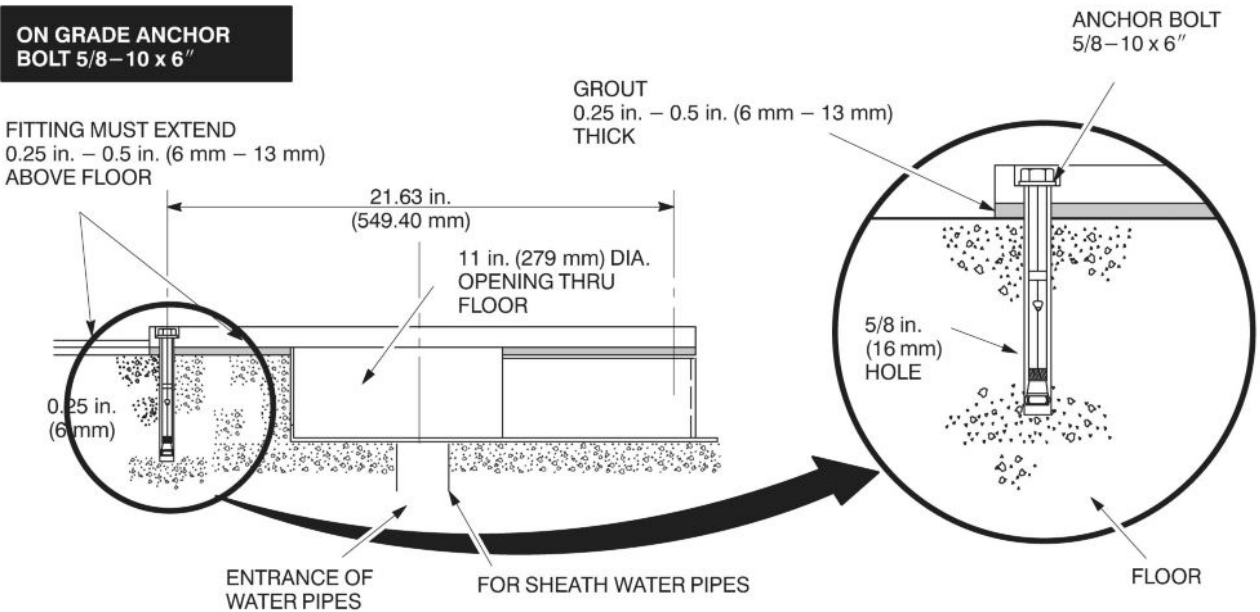
**Figure 99 Gantry Floor Mounting Methods (1/2)**

**ABOVE GRADE THRU BOLT M20**



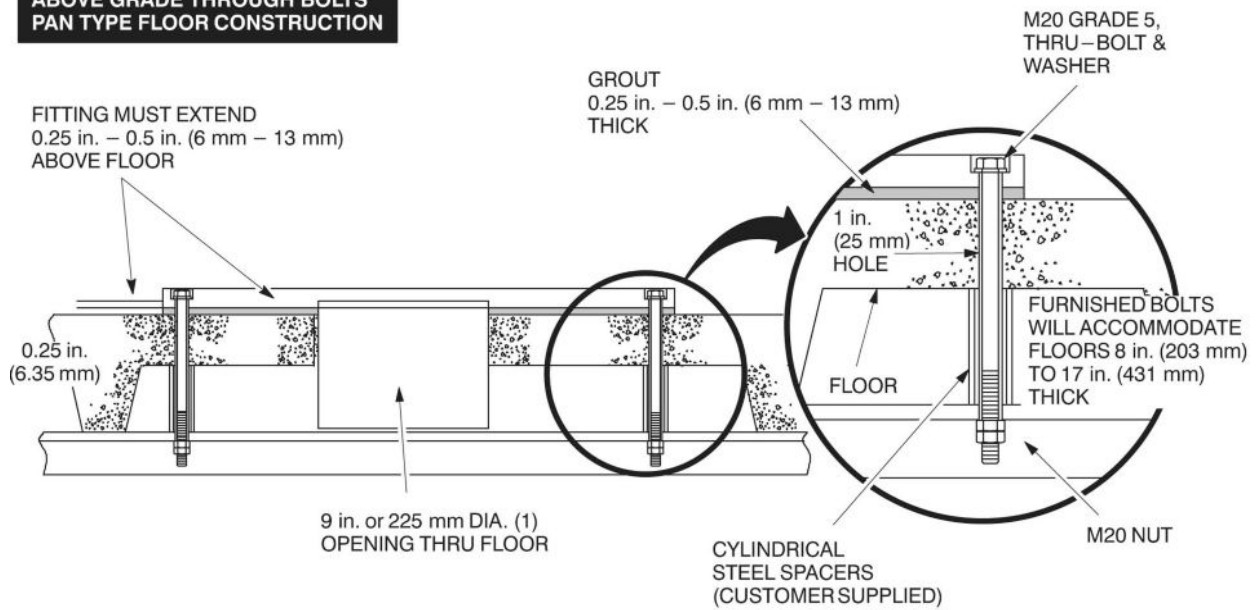
(1) The US or the METRIC standard for base plate inner

**ON GRADE ANCHOR BOLT 5/8-10 x 6"**



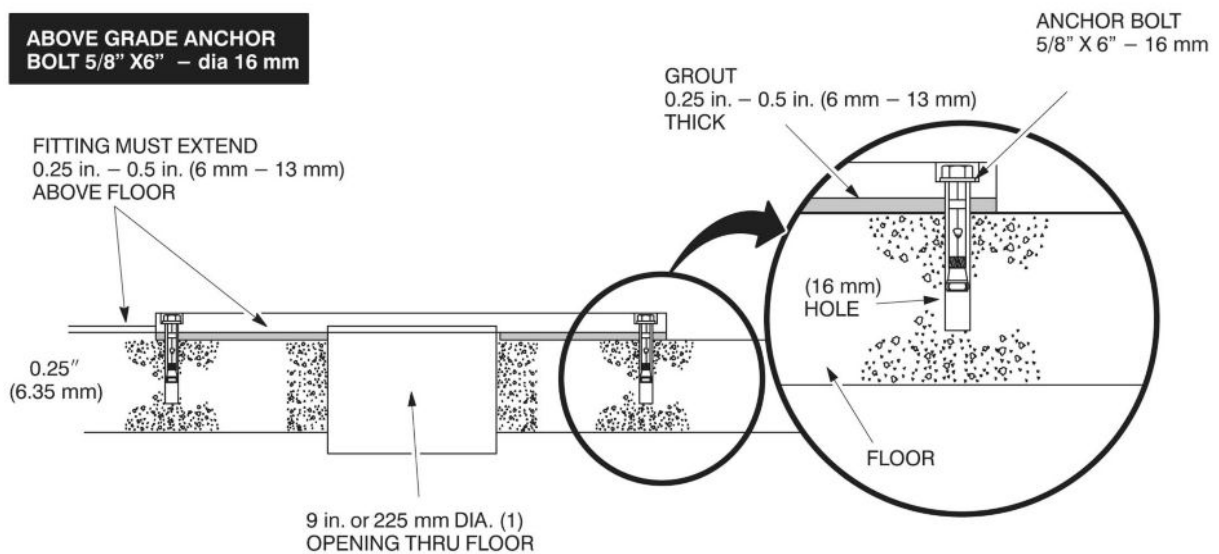
**Figure 100 Gantry Floor Mounting Methods (2/2)**

**ABOVE GRADE THROUGH BOLTS  
PAN TYPE FLOOR CONSTRUCTION**



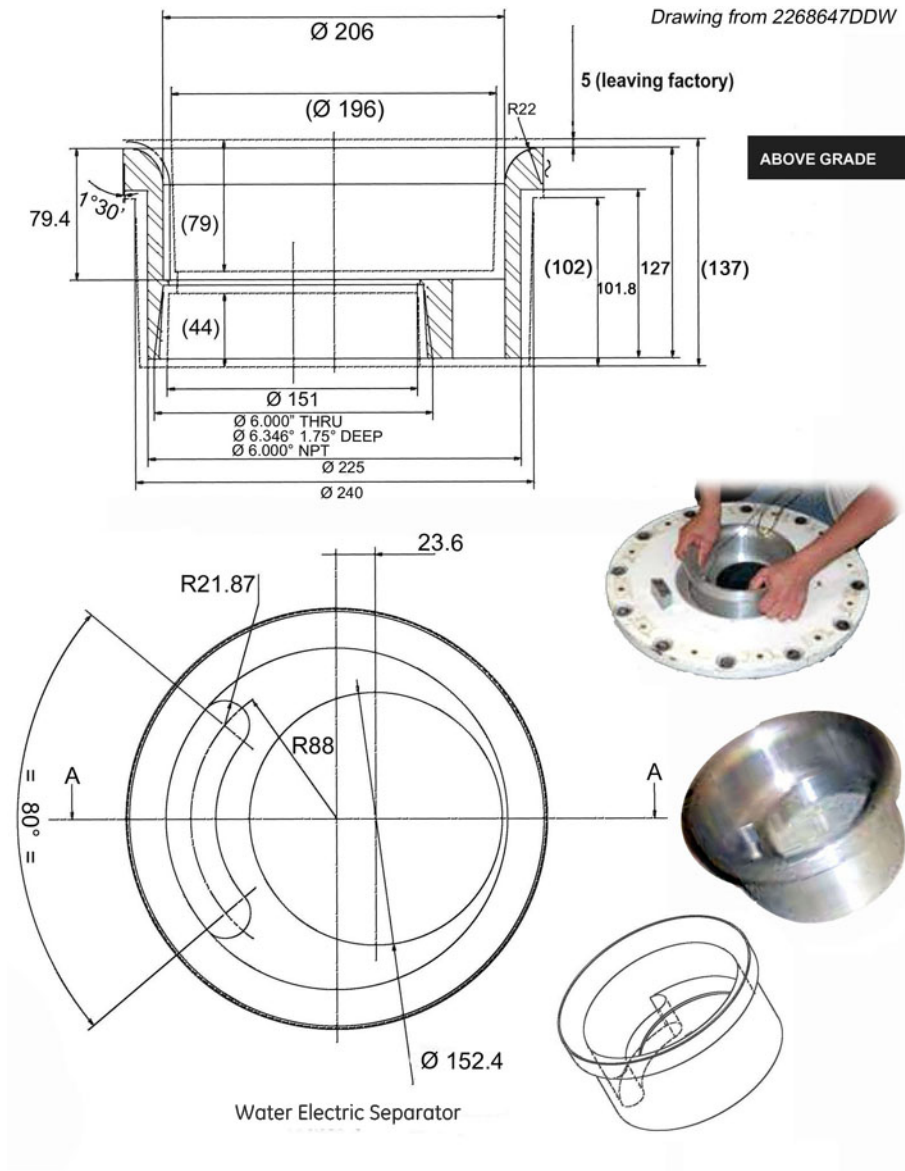
(1) The US or the METRIC standard for base plate inner

**ABOVE GRADE ANCHOR  
BOLT 5/8" X 6" – dia 16 mm**

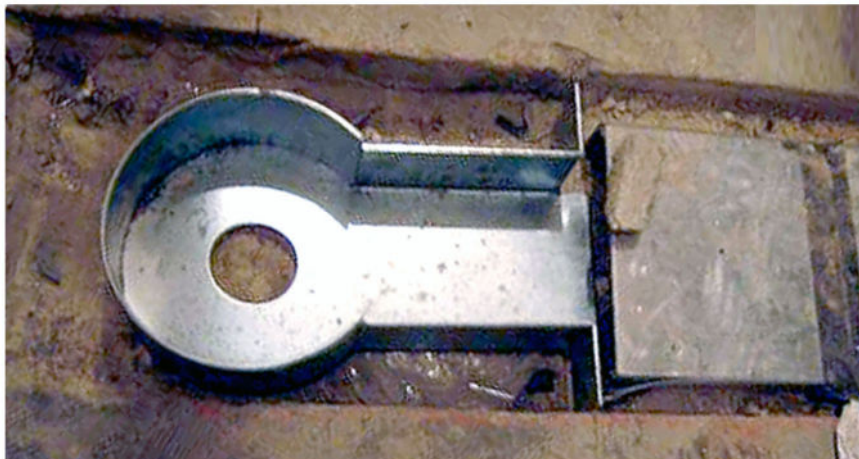


(1) The US or the METRIC standard for base plate inner

**Figure 101 Inner Base Plate (Water Electric Separator) for Above Grade Floor Anchor Kit**

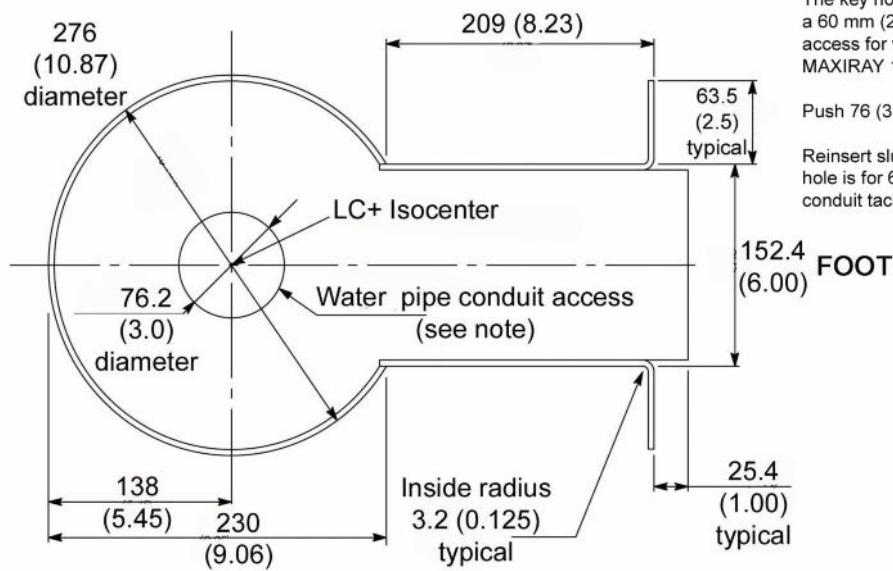


**Figure 102 Cable Conduit For On-Grade Floor Anchor Kit**



Dimensions in mm (inches)

**ON GRADE**

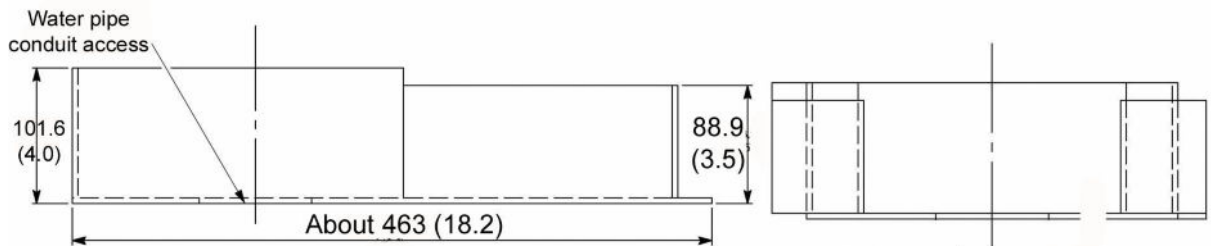


The key hole has been redesigned to permit a 60 mm (2.5 in.) water conduit to separate access for waterpipes used with a MAXIRAY 150.

Push 76 (3.0) hole in center.

Reinsert slug and tack well in one spot hole is for 63.5 (2.5) internal diameter conduit tack well from bottom if possible.

**FRONT VIEW**



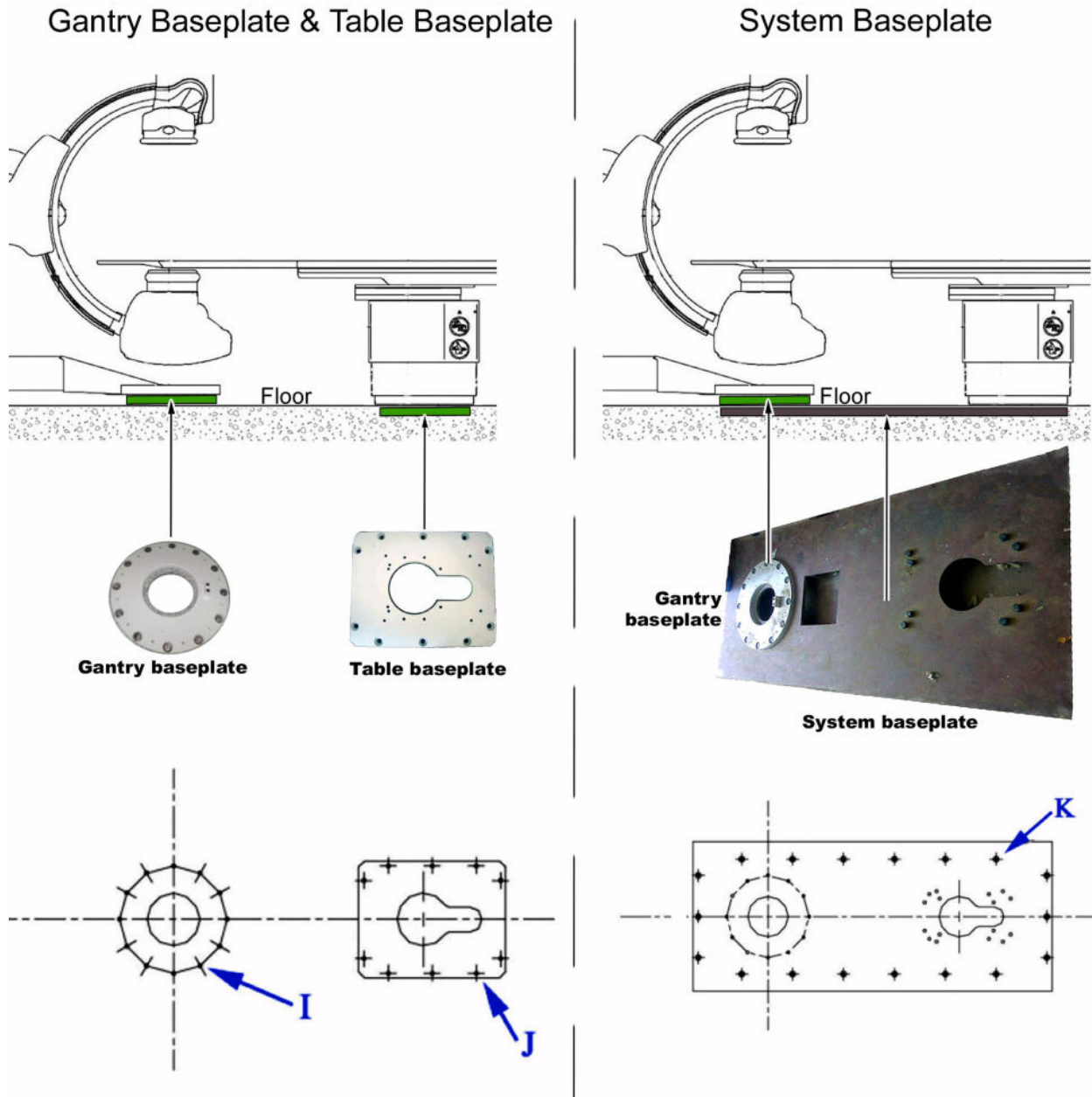
Steel plate (0.12 in) OR 3mm Thickness

FINISH: F50FX2A 1

**SIDE VIEW**

**FRONT VIEW (FOOT END)**

**Figure 103 Fixing Bolt Overview**



**NOTE**

For more details on Floor plate or Base plates, refer to [Figure 104 on page 129](#) and illustration *Hole location in concrete floor* in [Floor Requirements](#).

**NOTE**

With any kind of fixation methods (Bolts M20, Mechanical anchors or Chemical anchors), the mandatory number of holes used is:

- Gantry base plate : 12 max and 8 min holes used are acceptable
- Table base plate : 10 max and 8 min holes used are acceptable
- Floor base plate : 24 max and 12 min holes used are acceptable.

We can have only 2 consecutive holes omitted.

**NOTE**

In case of floor plate configuration, the gantry base plate shall be mounted onto the floor plate, but the table base plate shall not be mounted on the floor plate.

**Pull out efforts and recommendations about chemical anchors not provided by GE.**

The following table provides the recommended chemical anchors for Table/Gantry base plates and for the floor plate ordered locally that they could be used instead of bolts provided by GE.

**Table 19 Chemical anchors Pull out efforts and recommendations**

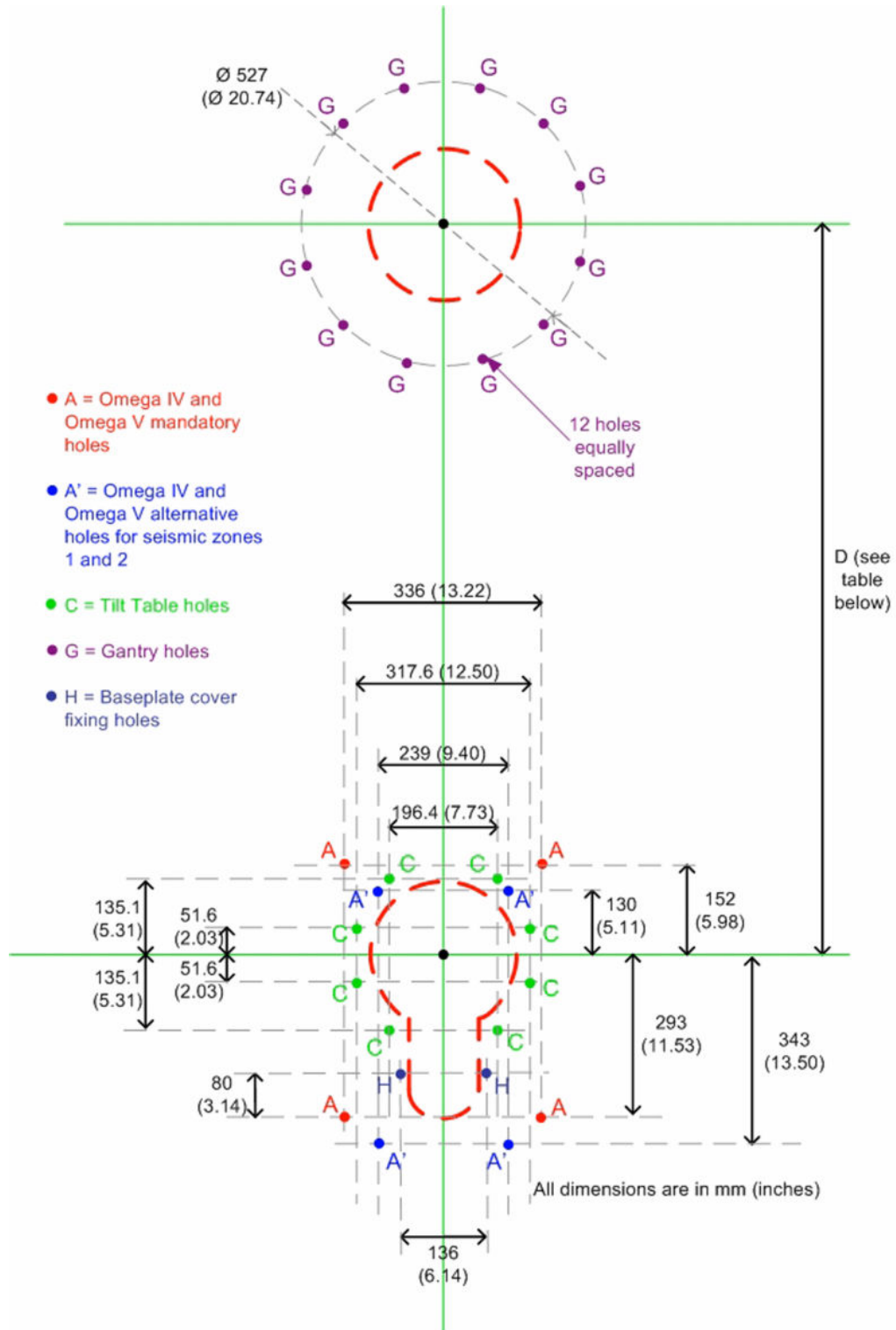
	<b>Gantry Base Plate</b>	<b>Table Base Plate</b>	<b>Floor Plate (to be ordered locally)</b>	<b>Table Omega</b>
Mark	<b>I</b> on Figure 103 on page 126	<b>J</b> on Figure 103 on page 126	<b>K</b> on Figure 103 on page 126	<b>A</b> on Figure 104 on page 129
Pull out effort	736 daN per bolt if 12 used and 1992 daN per bolt if 8 used	1120 daN per bolt if 10 used and 2000 daN per bolt if 8 used	272 daN per bolt if 24 used and 2008 daN per bolt if 12 used	4432 daN per bolt with 4 bolts
Number of holes in the plate	12 max (8 min mandatory)	10 max (8 min mandatory)	24 max (12 min mandatory)	4 mandatory
Recommended chemical anchors example 1	Supplier HILTIHVU adhesive capsule + HAS Anchor rod	Supplier HILTIHVU adhesive capsule + HAS Anchor rod	Supplier HILTIHVU adhesive capsule + HAS Anchor rod	Supplier HILTIHVU adhesive capsule + HAS Anchor rod
Threaded rod	M16 A4-70 / 333 131 5/8	M20 A4-70 / 333 135 3/4	M16 A4-70 / 333 131 5/8	M20 A4-70 / 333 135 3/4
Hole diameter in the floor	18 mm (11/16 in)	24 mm (7/8 in)	18 mm (11/16) in	24 mm (7/8 in)
Hole depth in the floor	125 mm (5 in)	170 mm (6-5/8 in)	125 mm (5 in)	170 mm (6-5/8 in)
Minimum floor thickness	180 mm (7 in)	220 mm (8-1/2 in)	180 mm (7 in)	220 mm (8-1/2 in)
Max Tightening Torque	80 N.m (59 ft-lb)	150 N.m (110 ft-lb)	80 N.m (59 ft-lb)	150 N.m (110 ft-lb)

**NOTE**

The floor plate ordered locally needs to be in steel.

Refer to supplier technical documents for all specification and installation data about chemical anchors.

Figure 104 Gantry and table mounting holes



**Table 20 D distance**

	<b>ANGIO mm (in)</b>	<b>CARDIO mm (in)</b>	<b>NEURO mm (in)</b>
Omega IV Compact Table	Not applicable	1395 (54.9)	Not applicable
Omega V Long Table	1278 (50.3)	1395 (54.9)	1395 (54,9)
Innova <sup>IQ</sup> Table	1278 (50.3)	1395 (54.9)	Not applicable

### 2.3.3.2 Gantry Table Floor Preparation Kits (GE supplied)

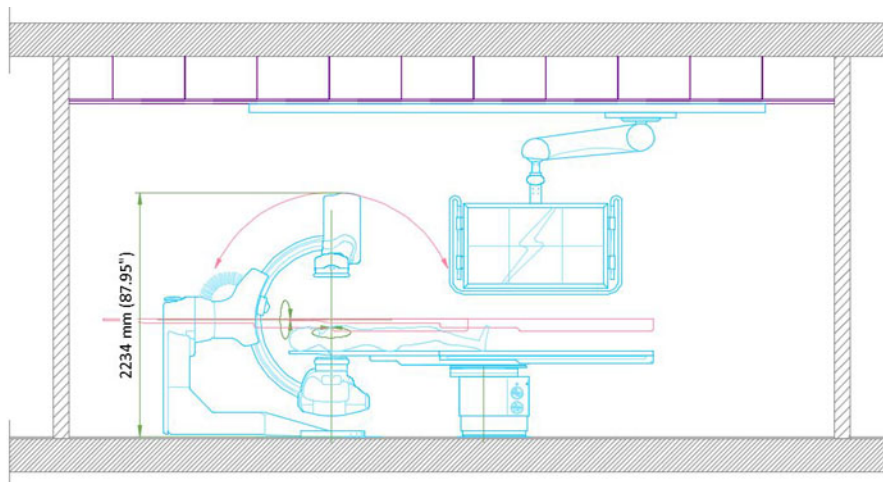
Refer to *.Single Plane and Biplane Innova Systems - Pre-Installation Kit Installation Procedures.*

## 2.3.4 Ceiling Requirements

### 2.3.4.1 Third Party Monitor suspension (option)

Attention must be paid to the height of suspended elements of the third party monitor suspension, collision must be avoided with the gantry.

**Figure 105 Gantry and Third Party Monitor Suspension**



### 2.3.4.2 Mavig suspension with rails

Aluminum rails support the In-Room Monitor bridge used in Innova systems X-Ray rooms.

**Reference:**

For additional details on ceiling requirements for stationary rails, refer to Direction 2393190 -1-1EN, *LCD monitor suspension for 2, 3, 4, 6 or 8 monitors - Pre-Installation Manual.*

When evaluating ceiling you must take into account the mounting information below.

### 2.3.4.2.1 Rail Mounting

Attach stationary rails to structural steel with through-bolts in concrete ceilings. Do not use screw anchors in direct tension.

Mount stationary rails directly to the ceiling slab or to flush-mounted unistrut or halfen structure. In higher rooms with false ceiling, mount stationary rails to rigid vertical members hung from ceiling slab.

Securing a supplementary channel to the bottom of the vertical members and mounting the stationary rails to this channel can greatly reduce the number of vertical members.

The stationary rail support structure must be leveled before installation can begin. Do not assume that any support structure is level within specified tolerances, particularly after removing suspensions from an existing room.

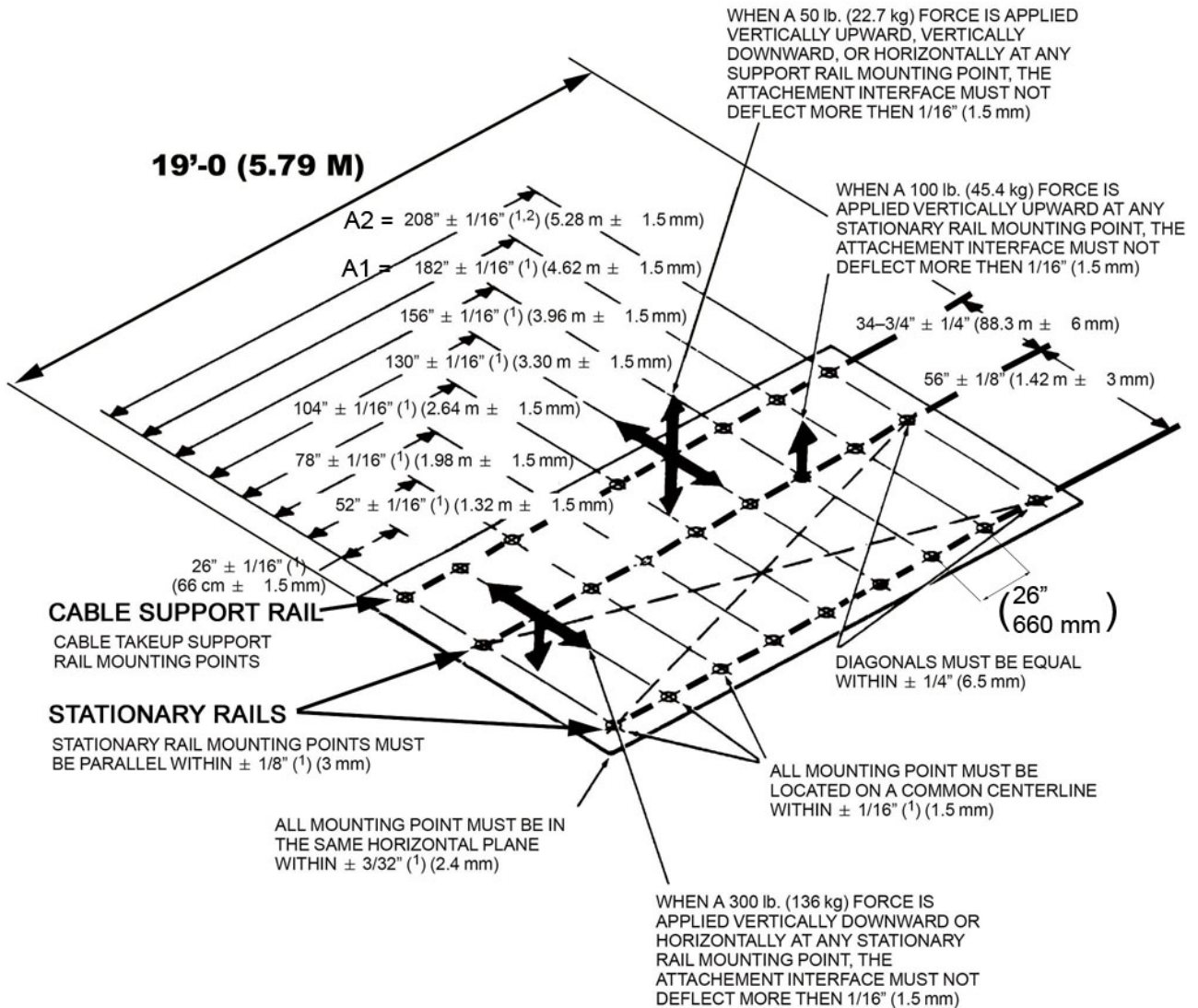
### 2.3.4.2.2 Bolt Specifications (Mavig suspensions)

- The maximum load per bolt will not exceed **1557 N (350 lbs)**.
- Each bolt must not “pull out” or otherwise fail under a vertically downward *dead* load of **6228 N (1400 lbs)**.

### 2.3.4.2.3 Select Rails (Mavig suspensions)

Monitor suspension rails in two length can be selected. Please refer to the Selectable item process or contact the GE representative.

**Figure 106 Specifications for a typical 19'-0 (5.79 m) inboard stationary rail mounting interface (both rails ceiling mounted), for Mavig suspension**



NOTES: 1. NONE CUMULATIVE ERROR.  
2. SPACE BETWEEN LAST 2 HOLES MAY BE LESS THAN 26" (66 cm)

**Table 21 Stationary rail in different length**

Rail length cm (in)	Number of holes	A	INBOARD RAILS
472 (186")	8	A1: 7 x 66 cm = 462 cm 7 x 26" = 182"	S18121RC
579 (228")	9	A2: 8 x 66 cm = 528 cm 8 x 26" = 208"	S18121RA

### 2.3.4.2.4 Cable Support for Monitor Cables

The rails & cable drape are provided with the system, except for the USA, where the Cable Support Kit must be provided locally by the Customer (e.g. CPGE55 from Unistrut).

### 2.3.4.3 MAVIG suspension with fixed point dual arm

The Substructure for Dual Arm suspension is used to attach the MAVIG suspension with fixed point dual arm to the solid ceiling. It is used as the bridging element between the solid ceiling and the false ceiling for the installation and the fixation of the suspension.

Also, it provides a hooking point required for the installation and the replacement of the Large Display Monitor.

The Substructure for Dual Arm suspension is mandatory to install the MAVIG suspension with fixed point dual arm for Non-seismic Zones. For Seismic Zone installations, refer to Structural Engineer for appropriate design of the structure for installing the MAVIG suspension system.

For standard site configurations, the distance between the ceiling and the lower edge of the false ceiling should be in a range of minimum 175 mm and maximum 610 mm.



**NOTICE**

If the distance between the ceiling and the lower edge of the false ceiling is more than 610 mm, Long variation of the Substructure for Dual Arm suspension solution could be proposed by MAVIG.

If the distance between the ceiling and the false ceiling is less than 175 mm, then the middle plate is not installed. Refer to [Table 22 on page 133](#)

**Table 22**

Distance between ceiling and false ceiling	Configuration of the Substructure for Dual Arm suspension	Item and Description
Minimum is 175 mm and maximum is 610 mm		[1]: Weight in kg [2]: Ceiling Plate [3]: Middle Plate [4]: Maximum is 155 mm [5]: Maximum is 175 mm
Less than 175 mm		

The Substructure for Dual Arm suspension is delivered with each system. In the GEHC system catalogue (Pre-Installation item), its purchase number is S18391MX (MAVIG Purchase number GD60D022).

### 2.3.4.3.1 Substructure for Dual Arm suspension mounting

The length of the Substructure for Dual Arm suspension S18391MX can be adapted to any individual situation (distance between solid ceiling and the lower edge of the false ceiling).

Length calculation and adaptation instruction are provided in the MAVIG substructure assembly instructions DBF0100X (where X may be 1 or higher).

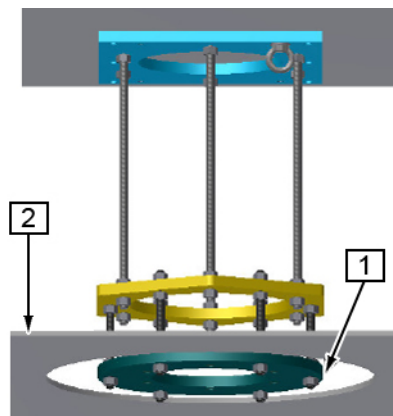
The Substructure for Dual Arm suspension must be fastened to the ceiling using six suitable screws.

These screws must be dimensioned according to the conditions of the ceiling and provided by the customer and must be checked by the structural engineer.

The ceiling plate (Figure 62 on page 86) must be seated flush to the ceiling in order to ensure optimum load distribution.

The lower edge of the Substructure for Dual Arm suspension (Interface plate **1**) should be the same as the height as the lower edge of the false ceiling **2**

**Figure 107 False ceiling alignment versus interface plate**



### 2.3.4.3.2 Bolt Specifications

The statics of the ceiling structure must be designed for safe, load bearing and transfer of the ceiling substructure with suspension arm system and attached devices plus any other existing load applied to the ceiling. In all cases a civil or structural engineer must be consulted.

The screws used to attach the system to the ceiling are not part of the system.

The Substructure shall be fastened to the ceiling with following specifications:

- The maximum axial load per bolt will not exceed 7210 N.
- The maximum Shear load per bolt will not exceed 957 N.
- The maximum pullout force shall be calculated in accordance with local building codes and it is part of structural analysis done by customer.

### 2.3.4.3.3 False ceiling specifications

The false ceiling should include an opening around the interface plate to allow service engineers to install and replace the suspension and the Large Display Monitor.

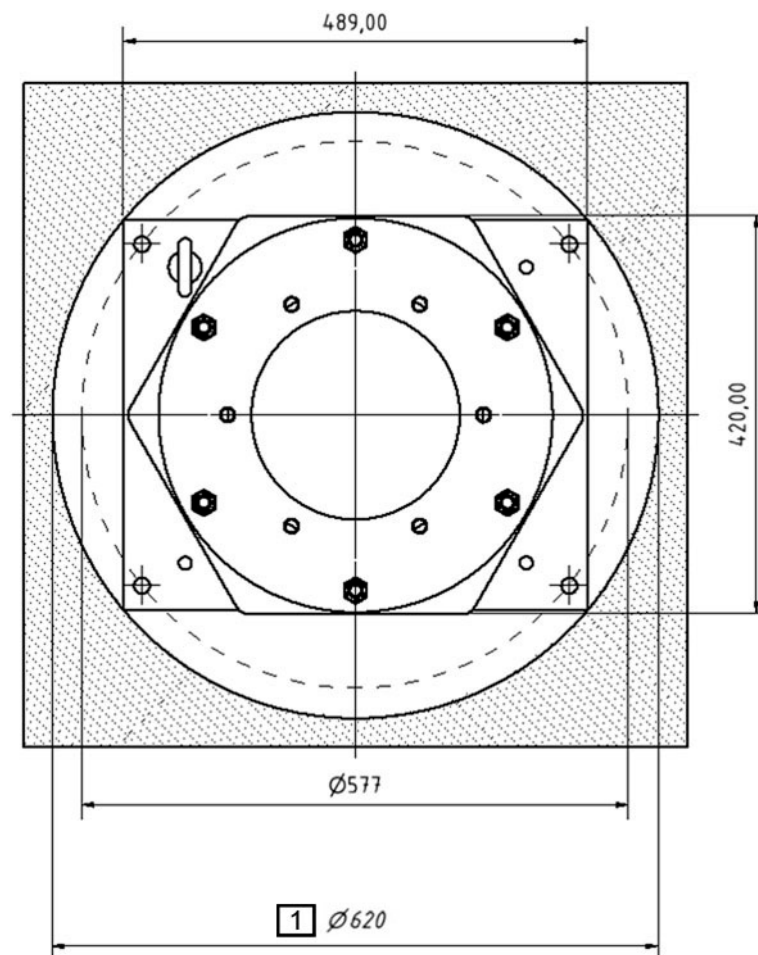
The diameter of the opening should be in the range of:

- 489-620 mm (Figure 108 on page 135) for a suspension for a Large Display Monitor.
- 577-620 mm (Figure 108 on page 135) for a suspension with 4 19" monitors.

A trapdoor in the false ceiling should be provided to allow service access for cables management after mechanical installation of the suspension.

The distance between the substructure and the trapdoor should be less than 50 cm.

**Figure 108**



**[1]:** Port diameter of the false ceiling: maximum is 620 mm.

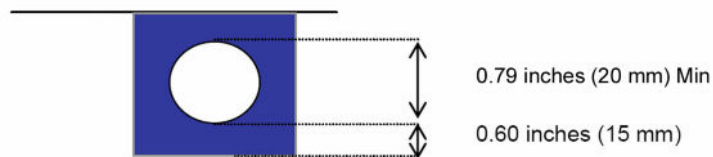
## 2.3.5 Wall Requirements

### 2.3.5.1 Optional Large Display secondary monitor

A hooking point shall be provided in order to lift the monitor on a third-party suspension during installation:

- Hooking point characteristic: It must withstand up to 440 lbs (200 kg).
- Recommended hooking point dimensions:

**Figure 109 Hooking point dimensions**



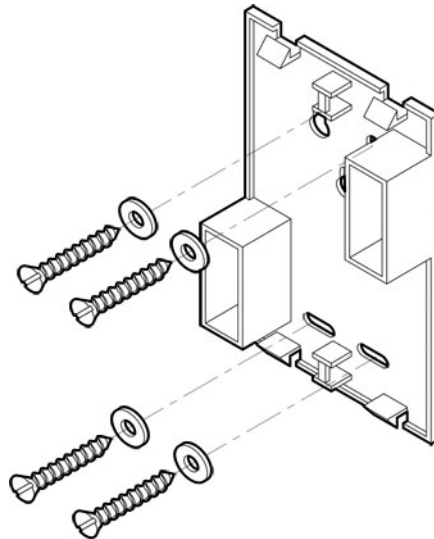
### 2.3.5.2 V-Point

The V-Point wall box is attached on the wall with four screws and four flat washers.

**NOTE**

The V-Point screws and washers are not provided with the kit. They should be provided under customer responsibility.

**Figure 110 V-Point Box attached on the wall**



## 2.4 Seismic

## 2.4.1 Seismic areas

Consider local seismic requirements when planning cabinet mounting.

Consult seismic expert to determine which mounting method is appropriate for the seismic region. Seismic requirements are determined and specified by the hospital/ Design Professional of record and may require approval by the specific state or country agency. Additional reinforcement in the walls may be required by specific seismic areas.

Contact your local GE Installation Program Manager to obtain the latest seismic calculations per the California Building Code (CBC) and the International Building Code (IBC).

The C-FRT Cabinet and the NPA PDU must be securely fastened to the wall and with their seismic kit to prevent them from tipping.

The C-FRT Cabinet, the Detector Conditioner and the Fluoro UPS are each provided with their own seismic kits, excluding the bolts, that shall be provided locally by the customer.

The following seismic kits can be ordered separately (on option):

- NPA PDU seismic kit: S18761PR
- Monitor Flat Panel seismic kit: 5561139
- VCIM seismic kit: 2365510
- 1 or 8 kVA UPS seismic kit: E4502YB.

The seismic kit for the Tube Chiller is provided locally by the customer.

**(For LDM Suspension with fixed point Dual Arm) :**



The standard substructure (MAVIG GD60D022) should not be used with system in seismic zone.

Contact MAVIG or Local contractor to design and supply specific substructure including M12 threaded holes requirement (see below).

Four M12 threaded holes with hooking point are required for the installation of the dual arm suspension, the installation and replacement of the Large Display Monitor. The structural support plate ([Figure 69 on page 93](#)) should include these 4 x M12 threaded holes.

For the threaded holes positioning on the structural support plate refer to [Figure 62 on page 86](#).

## 2.4.2 Center of Gravity

Refer to [2.1.3 Dimension Drawings on page 49](#) for location of Center of Gravity (CoG) of the system components.

Page intentionally left blank

# Chapter 3 Special Construction Requirements

## 3.1 Radiation Protection

Because X-ray equipment produces radiation, special precautions may be needed or special site modifications may be required. GEHC does not make recommendations regarding radiation protection. It is the customer's responsibility to consult a radiation physicist for advise on radiation protection in x-ray rooms.

## 3.2 EMI Consideration

Information below on IEC60601-1-2 Electromagnetic Standard Compliance & Documentation can also be found in the IGS System Operator Manual.

### 3.2.1 General Scope

This equipment complies with IEC 60601-1-2: Edition 2.1, Edition 3 and Edition 4 EMC standard for medical devices.

The IGS System is intended to be used:

- in a PROFESSIONAL HEALTHCARE facility environment and,
- in a SPECIAL ENVIRONMENT for OR configuration System (vicinity of active HF SURGICAL EQUIPMENT – refer to Installations Requirements & Environment Control.

The System is suitable to be used in the electromagnetic environment, as per the limits & recommendations described in the tables here after:

- Emission Compliance level & limits ([Table 23 on page 140](#)).
- Immunity Compliance level & recommendations to maintain equipment clinical utility (see [Table 24 on page 141](#), [Table 25 on page 142](#) and [Table 28 on page 145](#)).

### 3.2.2 Electromagnetic Emission

The IGS System is intended for use in the electromagnetic environment specified below.

The Customer or the user of the System should assure that it is used in such an environment.

**Table 23**

Emissions	Test Compliance	Electromagnetic Environment
Radio-Frequency Emissions CISPR11	Group1 Class A limits (refer to Note)	<p>The IGS System uses Radio Frequency energy only for its internal function. Therefore, its Radio Frequency emissions are very low and are not likely to cause any interference in nearby electronic equipment.</p> <p>The IGS System is suitable for use in all establishments other than domestic and those directly connected to the public low-voltage power supply network that supplies buildings used for domestic purposes.</p>
Harmonic emissions IEC 61000-3-2	Not applicable	The IGS System is suitable for use in all establishments other than domestic and those directly connected to the public low-voltage power supply network that supplies buildings used for domestic purposes.
Voltage fluctuations / flicker emissions IEC 61000-3-3	Not applicable	The IGS System is suitable for use in all establishments other than domestic and those directly connected to the public low-voltage power supply network that supplies buildings used for domestic purposes.

**NOTE**

The EMISSIONS characteristics of this equipment make it suitable for use in industrial areas and hospitals (CISPR 11 class A). If it is used in a residential environment (for which CISPR 11 class B is normally required) this equipment might not offer adequate protection to radio-frequency communication services. The user might need to take mitigation measures, such as relocating or re-orienting the equipment.

### 3.2.3 Electromagnetic Immunity

#### 3.2.3.1 Electromagnetic Immunity IEC 60601-1-2

The IGS System is intended for use in the electromagnetic environment specified below.

The Customer or the user of the System should assure that it is used in such an environment.


Table 24

Immunity Test	IEC 60601-1-2 Ed2.1 & 3 Test Level	IEC 60601-1-2 Ed4 Test Level (professional health-care environment)	Compliance Level	Electromagnetic Environment
Electrostatic discharge (ESD) IEC 61000-4-2	+/-6 kV contact +/-8 kV air	+/-8 kV contact +/-15 kV air	+/-6 kV contact +/-8 kV air	Floors are wood, concrete or ceramic tile or floors are covered with synthetic material and the relative humidity is at least 20 %.
Electrical fast transient/burst IEC 61000-4-4	+/-2 kV for power supply lines +/-1 kV for input/output lines 5 kHz burst repetition frequency	+/-2 kV for power supply lines +/-1 kV for input/output lines 100 kHz burst repetition frequency	+/-2 kV for power supply lines +/-1 kV for input/output lines 5 kHz & 100 kHz burst repetition frequency	Mains power quality is that of a typical commercial or hospital environment.
Surge IEC 61000-4-5	+/-1 kV line(s) to lines(s) +/-2 kV line(s) to earth	+/-1 kV line(s) to lines(s) +/-2 kV line(s) to earth	+/-1 kV line(s) to lines(s) +/-2 kV line(s) to earth	Mains power quality is that of a typical commercial or hospital environment.
Voltage dips, short interruptions and voltage variations on power supply input lines IEC 61000-4-11	<5 % $U_T$ (> 95 % dip in $U_T$ ) 0% for 5 sec	0 % $U_T$ ; 250/300 cycle	<5 % $U_T$ (> 95 % dip in $U_T$ ) 0% for 5 sec 0 % $U_T$ ; 250/300 cycle	Mains power quality is that of a typical commercial or hospital environment. If the user of the IGS System requires continued operation during power mains interruptions, it is recommended that the System be powered from an uninterruptible power supply.
Power frequency (50/60 Hz) magnetic field IEC 61000-4-8	3 A/m	30 A/m	30 A/m	Power frequency magnetic fields is at levels characteristic of a typical location in a typical commercial or hospital environment.
Note: $U_T$ is the AC mains voltage prior to application of the test level. 250/300 cycle means 250 periods at 50Hz or 300 periods at 60Hz.				

The IGS System is intended for use in the electromagnetic environment specified below.

The Customer or the user of the System should assure that it is used in such an environment.

**Table 25**

Immunity Test	IEC 60601-1-2 Ed2.1 & 3 Test Level	IEC 60601-1-2 Ed4 Test Level (professional health-care environment)	Compliance Level	Electromagnetic Environment
Conducted Radio Frequency IEC 61000-4-6	3 Vrms 150 kHz to 80 MHz	3 Vrms 150 kHz to 80 MHz 6 Vrms in ISM bands <sup>(1)</sup>	$V_1 = 3 \text{ Vrms}$ 150 kHz to 80 MHz 6 Vrms in ISM bands <sup>(1)</sup>	Portable and mobile RF communications equipment is used no closer to any part of the IGS System, including cables, than the recommended separation distance calculated from the equation applicable to the frequency of the transmitter.
Radiated Radio Frequency IEC 61000-4-3	3 V/m 80 MHz to 2.5 GHz	3 V/m 80 MHz to 2.7 GHz	$E_1 = 3 \text{ V/m}$ <sup>(4)</sup>	<p><b>Recommended separation distance:</b></p> $d = [3.5/V1]\sqrt{P}$ $d = [3.5/E1]\sqrt{P}, \text{ from 80 MHz to 800 MHz}$ $d = [7/E1]\sqrt{P}, \text{ from 800 MHz to 2.5 GHz}$ <p>Where <math>P</math> is the maximum output power rating of the transmitter in watts (W) according to the transmitter manufacturer and <math>d</math> is the recommended separation distance in meters (m).</p> <p>Field strengths from fixed RF transmitters, as determined by an electromagnetic site survey <sup>(2)</sup>, are less than the compliance level in each frequency range <sup>(3)</sup>.</p> <p>Interference may occur in the vicinity of equipment marked with the following symbol:</p> 

**NOTE**

(1): The ISM (industrial, scientific and medical) bands between 0,15 MHz and 80 MHz are 6,765 MHz to 6,795 MHz; 13,553 MHz to 13,567 MHz; 26,957 MHz to 27,283 MHz; and 40,66 MHz to 40,70 MHz.

(2): Field strengths from fixed transmitters, such as base stations for cellular telephones and land mobile radios, amateur radio, AM and FM radio broadcast, and TV broadcast cannot be estimated accurately. To assess the electromagnetic environment due to fixed RF transmitters, an electromagnetic site survey should be performed. If the measured field strength exceeds the RF compliance level above, observe the IGS System to verify normal operation in each use location. If abnormal performance is observed, additional measures may be necessary, such as re-orienting or relocating the IGS System.

(3): Over the frequency range 150 kHz to 80 MHz, field strengths are less than 3 V/m.

(4): Refer to Table and Notice below.


**NOTICE**

The IGS System is a Large, Permanently-Installed Medical Equipment for which the simulated operation in an anechoic chamber is not feasible and consequently is exempt from the testing requirement specified by IEC 61000-4-3.

The IGS System has not been tested for radiated RF immunity over the entire frequency range 80 MHz to 6 GHz.

The IGS System has been tested for radiated RF immunity only at selected frequencies. Use nearby of emitters at other frequencies could result in improper operation.

**Table 26 IEC 60601-1-2 Ed2.1 & 3 field level & frequencies**

Tested frequencies (MHz)	Field Level (V/m)	Modulation
433.92 (ISM)*	3	80 % AM at 1 kHz rate
915 (ISM)*		
1440		
1750		
1920		
2450 (ISM)*		

**NOTE**

\* Industrial, Scientific and Medical (ISM) radio bands.

**NOTE**

These are guidelines. Actual conditions may vary.

The associated recommended separation distances as per IEC 60601-1-2 Ed2.1 & 3 are listed in [Table 28 on page 145](#).

Additional IEC 60601-1-2 Ed4.0 field level & frequencies - immunity to proximity fields from RF wireless equipment:

**Table 27 IEC 60601-1-2 Ed4.0 field level & frequencies**

Tested frequencies (MHz)	Field Level (V/m)	Modulation
385	27	Pulse modulation (50% duty cycle) – 18 Hz
450	28	Pulse modulation (50% duty cycle) – 18 Hz
710	9	Pulse modulation (50% duty cycle) – 217 Hz

IEC 60601-1-2 Ed4.0 field level & frequencies continued		
Tested frequencies (MHz)	Field Level (V/m)	Modulation
710	9	Pulse modulation (50% duty cycle) – 217 Hz
745	9	Pulse modulation (50% duty cycle) – 217 Hz
780	9	Pulse modulation (50% duty cycle) – 217 Hz
810	28	Pulse modulation (50% duty cycle) – 18 Hz
870	28	Pulse modulation (50% duty cycle) – 18 Hz
930	28	Pulse modulation (50% duty cycle) – 18 Hz
1720	28	Pulse modulation (50% duty cycle) – 217 Hz
1845	28	Pulse modulation (50% duty cycle) – 217 Hz
1970	28	Pulse modulation (50% duty cycle) – 217 Hz
2450 (ISM)*	28	Pulse modulation (50% duty cycle) – 217 Hz
5240	9	Pulse modulation (50% duty cycle) – 217 Hz
5500	9	Pulse modulation (50% duty cycle) – 217 Hz
5785	9	Pulse modulation (50% duty cycle) – 217 Hz
5800 (ISM)*	9	Pulse modulation (50% duty cycle) – 217 Hz

**NOTE**

\* Industrial, Scientific and Medical (ISM) radio bands.

**NOTE**

These are guidelines. Actual conditions may vary.

Equipment used for tests:

- RF signal generator,
- RF power amplifier,

- Transmitting antenna,
- Field sensor,
- Field meter.



PORTABLE RF COMMUNICATIONS EQUIPMENT INCLUDING PERIPHERALS (SUCH AS ANTENNA CABLES AND EXTERNAL ANTENNAS) SHOULD BE USED NO CLOSER THAN 30 CM (12 INCHES) TO ANY PART OF THE IGS SYSTEM INCLUDING CABLES SPECIFIED BY THE MANUFACTURER. OTHERWISE, DEGRADATION OF THE PERFORMANCE OF THIS EQUIPMENT COULD RESULT.

### 3.2.3.2 Recommended Separation Distances for Portable and Mobile RF Communications Equipment IEC 60601-1-2 (Ed2.1 & 3)

Table 28

Frequency of Transmitter	150 KHz to 80 MHz	80 MHz to 800 MHz	800 MHz to 2.5 GHz
Equation	$d = [3.5 / V_1] \sqrt{P}$	$d = [3.5 / E_1] \sqrt{P}$	$d = [7 / E_1] \sqrt{P}$
Rated Power of Transmitter (watts)	Distance (meters)	Distance (meters)	Distance (meters)
10 mW	0.11	0.11	0.22
100 mW	0.37	0.37	0.74
1	1.1	1.1	2.3 (*)
10	3.7	3.7	7.4
100	12	12	23

For transmitters rated at a power not listed above, the DISTANCE can be estimated using the equation in the corresponding column, where P is the power rating of the transmitter in watts (W) according to the transmitter manufacturer.

#### NOTE

These are guidelines. Actual conditions may vary.

### 3.2.4 Limitations Management

Adhering to the distance separation recommended in [Table 28 on page 145](#), between 150 kHz & 2.5 GHz, will reduce disturbances recorded at the image level, but may not eliminate all disturbances. However, when installed and operated as specified herein, the IGS System will maintain its essential performance by continuing to acquire, display, and store diagnostic quality images safely.

For example, a 1W mobile phone (800 MHz to 2.5 GHz carrier frequency) shall be put 2.3 meters (see (\*) [Table 28 on page 145](#)) apart from the IGS System (in order to avoid images interferences risks).

### 3.2.5 Installations Requirements & Environment Control



USE OF ACCESSORIES, TRANSDUCERS AND CABLES OTHER THAN THOSE SPECIFIED OR PROVIDED BY THE MANUFACTURER OF THIS EQUIPMENT COULD RESULT IN INCREASED ELECTROMAGNETIC EMISSIONS OR DECREASED ELECTROMAGNETIC IMMUNITY OF THIS EQUIPMENT AND RESULT IN IMPROPER OPERATION.

Compatibility with HF SURGICAL EQUIPMENT:

The System configurations that could be used in operating room are compatible with HF surgical equipment. During HF surgery, the System shall remain in stand-by mode (no motions or X-Ray acquisition) when the HF surgical equipment is activated.



**NOTICE**

In order to minimize interference risks, the following requirements shall apply:

- Electrical equipment may disturb and interfere with System components. The control of the clearing distances from the noise sources is recommended from the HF electrosurgery generator, power supplies converters from nearby monitors or from other close electrical equipment). Refer to respective device manufacturers instructions & recommendations in such cases.
- Electrostatic discharges environment & recommendations:
  - In order to reduce electrostatic discharge interference, install a charge dissipative floor material to avoid electrostatic charge buildup.
  - The relative humidity shall be within the specification defined in [4.1 Humidity, Temperature and Altitude on page 147](#).
  - The dissipative material shall be connected to the room protective earth or equipotential conductor, if applicable.

# Chapter 4 Environmental Requirements

## 4.1 Humidity, Temperature and Altitude

### 4.1.1 Humidity

**Table 29 Relative Humidity (non- condensing)**

	MIN	MAX
Exam Room	20%	70%
Control Room	20%	75%
Technical Room	20%	75%

### 4.1.2 Temperature and Altitude

The system is certified for use up to 3000 m. The permissible atmospheric pressure conditions of use are between 700 hPa and 1060 hPa.

Above 2000 m, the thermal dissipation is reduced because the air pressure is lower. Therefore, a temperature derating shall be applied for the Technical Room as defined in the table below.

**Table 30 Exam Room and Control Room - Temperature**

	MIN	MAX	RECOMMENDED
Exam Room	+15°C (+59°F)	+32°C (+90°F)	+20°C (+68°F)
Control Room	+15°C (+59°F)	+35°C (+95°F)	+20°C (+68°F)

**Table 31 Technical Room - Temperature**

	Temperature up to 2000 m			Temperature above 2000 m		
	MIN	MAX	RECOMMENDED	MIN	MAX	RECOMMENDED
Technical Room (with 1 kVA)	+10°C (+50°F)	+30°C (+86°F)	+20°C (+68°F)	+10°C (+50°F)	+20°C (+68°F)	+20°C (+68°F)
Technical Room (with 8 kVA or the Fluoro UPS)	+15°C (+59°F)	+25°C (+77°F)	+20°C (+68°F)	+15°C (+59°F)	+20°C (+68°F)	+20°C (+68°F)

**NOTE**

For the systems that are planned to be installed at the second floor or above, the temperature and humidity of the rooms that are directly below the gantry room should be the same as the Exam Room requirement.

Differences in temperature or humidity between the Exam room and the room located below will cause condensation within the gantry or patient table, resulting in part failure or rust. Failure to do so will void the equipment warranty. Avoid above grade installations if the temperature is high in the area below the cables entrance of the gantry or table.

## 4.2 Heat Output

In the table:

- Moderate Use corresponds to 8 cases per a 10 hours day,
- Typical Use corresponds to 11 cases per a 10 hours day,
- Maximum Use is maximum peak power during exam.

**Table 32**

		HEAT OUTPUT							
		Stand by		Moderate Use		Typical Use		Maximum Use	
Room	Core System	kW	BTU/hr	kW	BTU/hr	kW	BTU/hr	kW	BTU/hr
Exam Room	Gantry and Table	0.41	1,399	0.55	1,877	0.89	3,037	1.62	5,528
	6 19" monitors on suspension or	0.30	1,024	0.30	1,024	0.30	1,024	0.30	1,024
	LDM suspension with 2 backups	0.10	341	0.10	341	0.10	341	0.10	341
	Typical Injector	0.09	307	0.09	307	0.09	307	0.09	307
Control Room	DL console and Live monitor	0.10	341	0.10	341	0.10	341	0.10	341
Technical Room	C-FRT Cabinet	0.70	2,388	1.02	3,480	1.53	5,221	2.16	7,370
	PDU	0.50	1,706	0.50	1,706	0.50	1,706	0.50	1,706
	Tube Chiller	2.53	8,633	4.49	15,321	5.49	18,733	6.93	23,646
	Detector Conditioner	0.21	717	0.21	717	0.21	717	0.21	717
	UPS 1 kVA	0.15	500	0.15	500	0.15	500	0.15	500
	UPS 8 kVA	0.52	1,760	0.52	1,760	0.52	1,760	0.52	1,760
	Fluoro UPS	2.14	7,302	2.14	7,302	2.14	7,302	2.14	7,302
Total for Core System with the 1 kVA UPS		4.79	16,332	7.21	24,590	9.06	30,902	11.86	40,456
Total for Core System with the 8 kVA UPS		5.16	17,592	7.58	25,850	9.43	32,162	12.23	41,716
Total for Core System with the Fluoro UPS		6.78	23,134	9.20	31,392	11.05	37,704	13.85	47,258

## 4.3 Acoustic Specifications

- Less than 50 dB (A) at 1 meter for Gantry.
- Limited to 50 dB (A) at 1 meter for Omega IV Table and Omega V Table.
- Limited to 58 dB (A) at 1 meter for Innova<sup>IQ</sup> Table.
- Limited to 59 dB (A) at 1 meter for C-FRT Cabinet and NPA PDU.
- Limited to 60 dB (A) at 1 meter for the Tube Chiller.
- Limited to 52 dB (A) (background of 35 dB (A)) at 1 meter for Detector Conditioner.
- Limited to 39 dB (A) at 1 meter for UPS 8 kVA.
- Less than 60 dB (A) at 1 meter for the Fluoro UPS.
- less than 55 dB (A) at 20 degrees Celsius, measured in the operators head position, 20 cm in front of the keyboard's right corner, at 1.30 m above the floor, and in a distance of 1 meter at all four sides.

## 4.4 Room Light

### 4.4.1 Requirements for Lighting

Requirement for lighting concern the following, general, light-technique characteristics:

- Illuminator level.
- Lighting distribution.
- Preventing the operator from being dazzled by the light (by direct light sources or by reflection on bright objects).

The Illumination level must be compliant with established lighting technical rules and be as constant as possible.

Technical Room, Exam Room and Control Room shall be provided with appropriate lighting in the maintenance area (maintenance area to be considered are service workplaces). It corresponds to service areas as defined for any of the product components.

The minimum required average luminance  $E_m$  shall be of 500 lux and minimum color rendering factor  $R_a$  of 80 as per IEC/EN 12464-1 (Light and lighting. Lighting of work places. Indoor work places: Illumination requirements for indoor workplaces corresponding to assembly of medium size electrical components, e.g. control panel) for the electrical industry).

### 4.4.2 Windows and Curtains

When the Exam Room has a window with an aperture outside of the controlled light area (day light, other...) a curtain has to maintain the light intensity under a limit fixed to 150 lux.

#### NOTE

In Germany: Ambient luminance of 100 lux maximum is required to maintain Exam Room class 2 according to DIN 6868-157.

### 4.4.3 Surgical Lights



If a surgical light is installed by the customer, it has to be powered from an independent power supply (provided by the hospital not by the System).

Page intentionally left blank

# Chapter 5 Electrical Requirements

## 5.1 System Electrical Ratings

### 5.1.1 Electrical Ratings

**Table 33**

Nominal voltage	Frequency	Power consumption			Type of power input	
		Long time	Momentary	Peak	With 1 & 8 kVA UPS	With 20 kVA UPS
380 V	50 Hz or 60 Hz	18 kVA	100 kVA	150 kVA	3~	3N~
400 V						
415 V						
480V	60 Hz					

Long time rating is measured in fluoroscopy mode at 30 fps, 120 kV, 89 mA, 10 ms.

Momentary rating is measured in record DSA mode at 7.5 fps, 125 kV, 640 mA, 50 ms.

For the rating of the external devices not powered by the system (AW, injector, and so on), refer to the OEM documentation.

Max Line Impedance for the line phase to phase at the entry of the X-rays Generator in C-FRT Cabinet (from IEC 601-2-7):

**Table 34**

V	380	400	415	480
$\Omega$	0.09	0.096	0.102	0.12

### 5.1.2 Additional Transformer characteristics

If a transformer is needed to power the system (e.g. when the mains is not within the nominal value of the system, or if an insulation from other devices is needed), it shall have the following characteristics:

- 150 kVA minimum for input voltage of 380 V and 400 V.
- 100 kVA minimum for input voltage of 415 V and 480 V.
- The transformer impedance shall be 4.5 % or less (this parameter is also called %Z or short circuit voltage).

### 5.1.3 Additional Full UPS

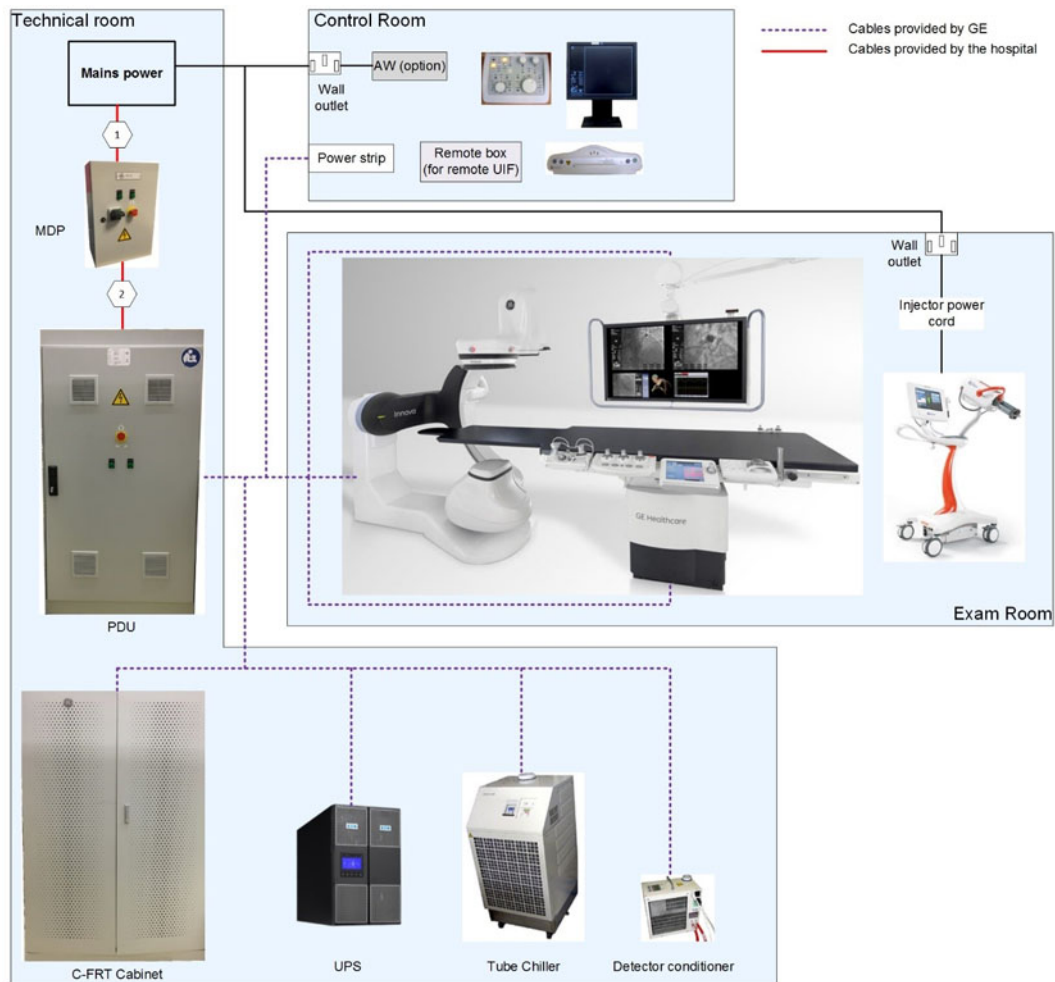
If it is required to power continuously the system in record mode during power failure, a 150 kVA UPS can be used in front of the system. Such an UPS will provide to the customer about 10 minutes of autonomy. This UPS comes in addition to the UPS provided with the system.

## 5.2 Power Distribution Schematics

Information below specifies the cables provided by GE and the cables provided by the Hospital. Refer to MDP Cabling Requirements on page 163.

### 5.2.1 System with 1 or 8 kVA UPS

Figure 111 Power Distribution with 1 kVA UPS or 8 kVA UPS

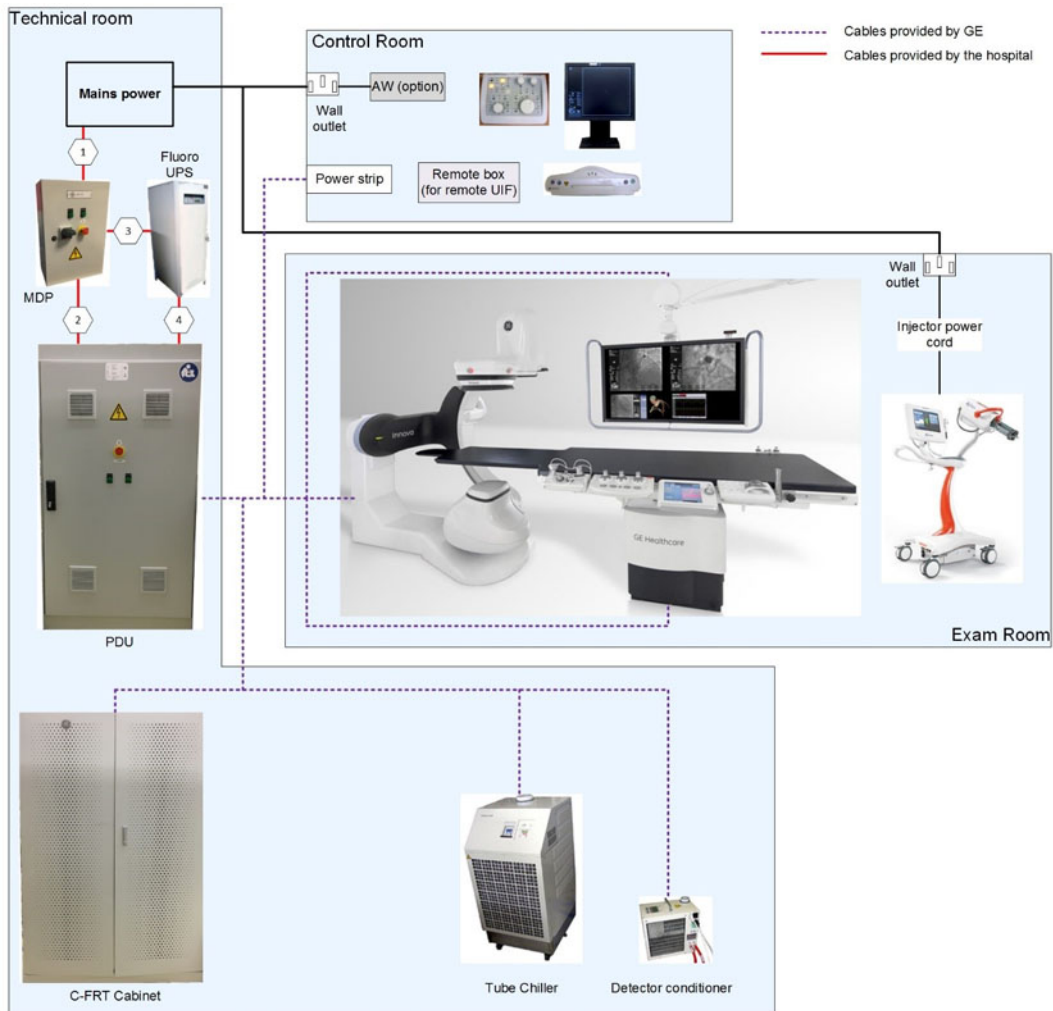


**NOTE**

UPS 1 kVA is only provided with System with Omega Table.

## 5.2.2 System with Fluoro UPS

Figure 112 Power Distribution with Fluoro UPS



## 5.2.3 System with Fluoro UPS and IT Electrical Network

The Fluoro UPS requires a Neutral line connected to the Protective Earth. For hospitals with an IT Electrical Network, a transformer is required with Delta-Wye or Delta-Star connection.

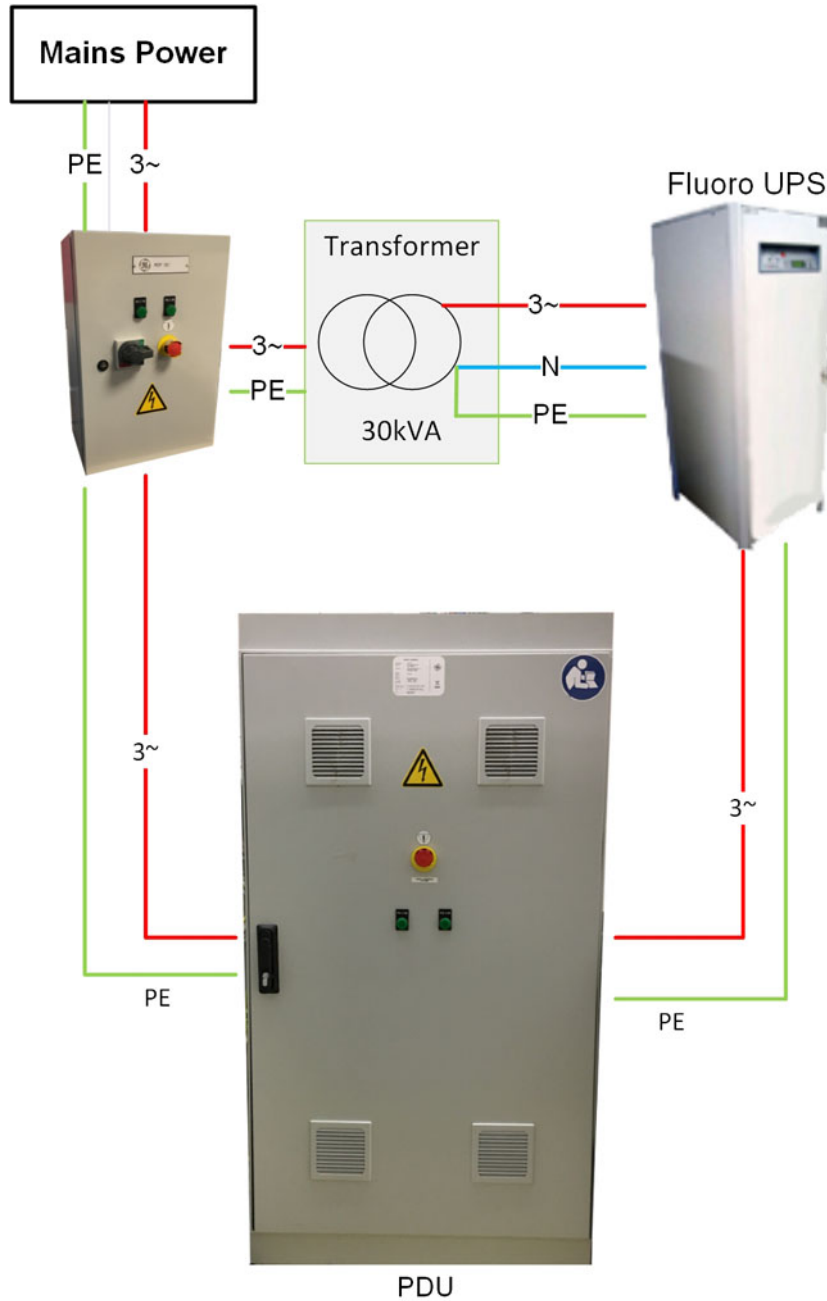
This transformer shall be provided by the customer; its characteristics shall be:

- 30 kVA minimum.
- Secondary star 3 Ph+N.
- The power distribution shall be of TNS type with the Neutral grounded.
- The transformer impedance shall be 4.5% or less (this parameter is also called %Z or short circuit voltage).

It is also the responsibility of the customer to provide:

- The box of the transformer to avoid access to live parts according to local regulations.
- The current protections at the output of the transformer, fuses or breaker, as per local regulations. The suggested rating is 50A.

**Figure 113 Power Distribution with Fluoro UPS and IT Electrical Network**



## 5.2.4 Power distribution for 3rd party monitors on GE 19" monitors suspensions

GE 19" monitors suspensions are pre-equipped for the connection of one monitor for 3rd party devices (ECG, ultrasound,...). It allows the connection of the video signal through a VGA cable or a DVI extender. The power connection is pre-routed between the connection box in the suspension and the monitor.

This 3rd party monitor shall not be powered by the system, but by a dedicated hospital power outlet. This power outlet shall be fitted with a dedicated overcurrent protection (e.g. circuit breaker) and a means of isolation with provision for Lockout/Tagout, accessible at all times. A fuse or a semiconductor device shall not be used as a means of isolation. A unique device can serve as circuit breaker and means of isolation, provided it meets all the requirements below.

The installation shall be done in accordance with all local regulations.

1. Technical requirements for the overcurrent protection:
  - The rating of the circuit breaker shall be less than 12A.
  - The breaking capacity of circuit breaker must be adapted to upstream input line breaking capacity.

2. Technical requirements for the means of isolation:

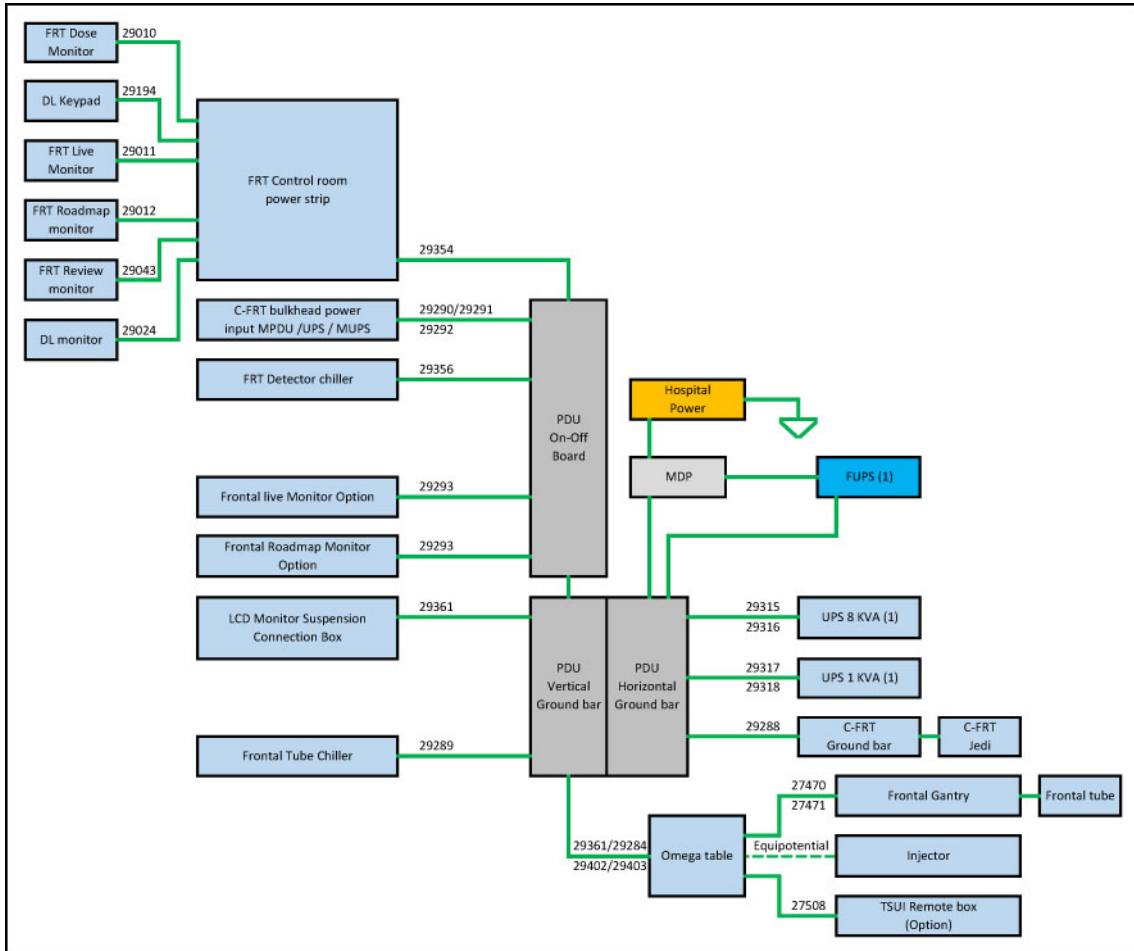
The means of isolation shall comply with the following requirements:

- rated Impulse Withstand Voltage (Uimp): 4 kV
- provision for Lockout/Tagout (LOTO)
- opens all poles simultaneously
- direction of movement of the actuator complies with IEC 60447 (The OFF to ON direction must be left to right, bottom to top or clockwise)

The power cable between the hospital outlet and the connection box of the suspension shall be provided by the hospital, its diameter shall be in accordance with the rating of the overcurrent protection.

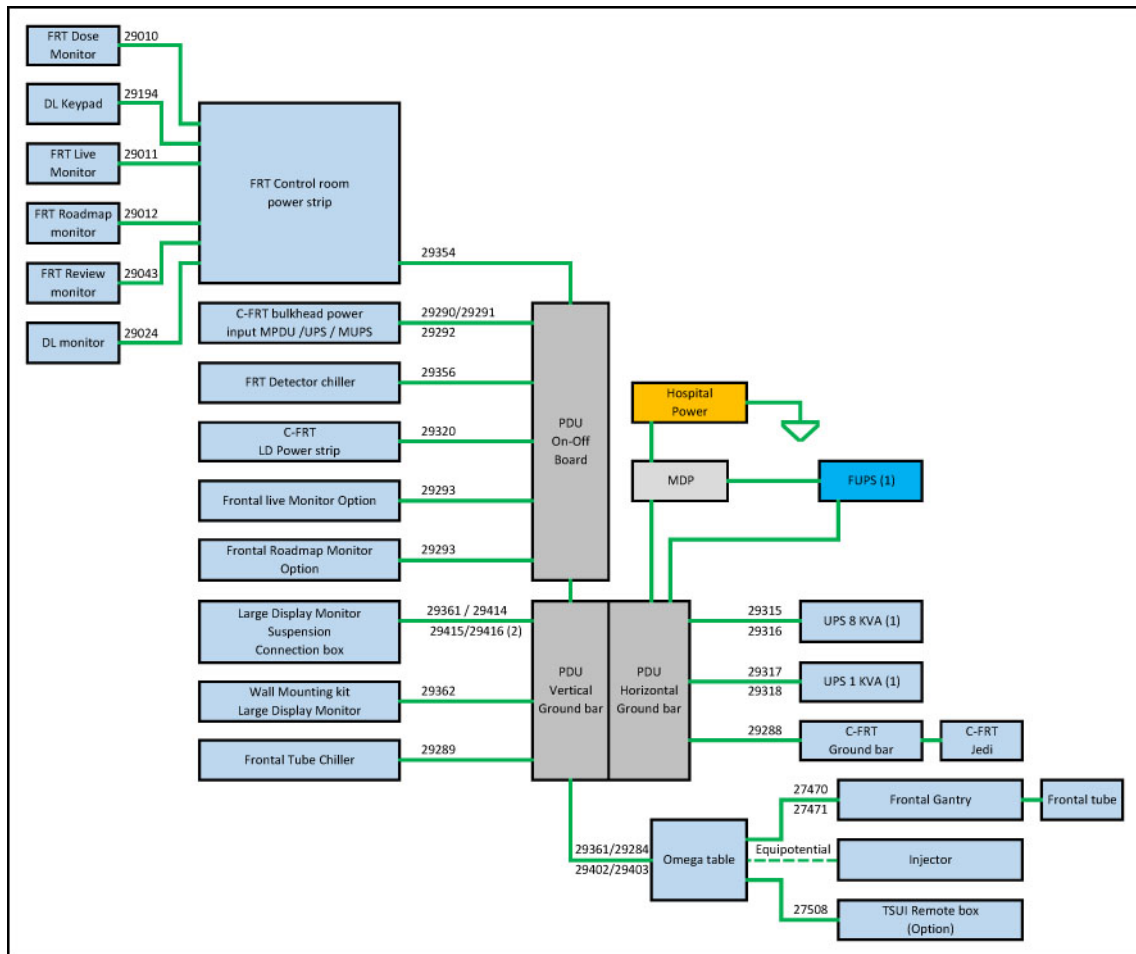
## 5.3 Grounding Schematics

Figure 114 System with 19" Monitors



(1) The system is provided with one UPS

**Figure 115 System with Large Display Monitors**



- (1) The system is provided with one UPS
- (2) MIS 29414, MIS 29415 and MIS 29416 are connected only with a Third-Party LDM suspension

## 5.4 Mains Disconnect Panel

### 5.4.1 General Information

#### 5.4.1.1 Introduction

The Mains Disconnect Panel (MDP) is the electric panel which is the interface between the Hospital mains and the System. It allows the power connections from the hospital power to the input of the PDU of the system and to the Fluoro UPS if present. It provides the LOTO (lock out – tag out) functions that allows safe service operation, and is part of the EPO (Emergency Power Off) function.

As the requirements applicable to electric panels vary from a country to another, information below lists the GE mandatory requirements to provide safe system operation and the installation precautions, in addition to the local regulatory requirements.

Information given shall allow the Customer to build the MDP in compliance with GE's rules. In addition, the following MDP can be ordered through the GE accessory catalog:

- MDP CE (E46001BB), certified IEC 61439-1,
- MDP UL (E46001BA), certified UL508A for USA,
- MDP UL (E46001BD), certified UL508A for USA and OSPHD.



**The Customer MDP is not covered by the GEHC product certification. The association of the Innova™ System and the Customer MDP is not covered by the GEHC product certification.**

**GE specifically disclaims any and all liability arising out of or relating to the use or performance of the MDP and the cables in the scope of Innova™ IGS 5 Pre-Installation Manual, including, and without limitation, any liability or claims relating to patient injury, death, or the reliability of such MDP.**

**The mechanical and electrical installation of the MDP is fully under the customer and the installer responsibility.**

**The customer is responsible for ensuring that all requirements from the Innova™ IGS 5 Pre-Installation Manual are met.**

#### 5.4.1.2 Pre-Installation

It is the customer responsibility to ensure that the MDP and its input and output cables are installed prior to the GE equipment (PDU, other cabinets, FUPS option, etc.) to ensure that standard GE Service Process can be followed during the System installation. The connection of the MDP to the GE equipment shall only be made in presence of a GE Service representative.

It is recommended that the vendor contacts GE Service representative and reviews the site planning details before the MDP is installed.

#### NOTE

GE will not be responsible for any delay in installation if the MDP is not mounted and its cables not routed before GE parts arrive on site.

### 5.4.1.3 Spare Parts

The customer is responsible for providing and replacing any part of MDP.

## 5.4.2 Mandatory Construction Requirements

### 5.4.2.1 Input Power

The MDP shall be functional within one the following input voltage and frequency ranges from the Hospital mains:

- Voltage range for systems without the Fluoro UPS:
  - 380 V +/-10% 3~, 50 Hz or 60 Hz +/-3 Hz
  - 400 V +/-10% 3~, 50 Hz or 60 Hz +/-3 Hz
  - 415 V +/-10% 3~, 50 Hz or 60 Hz +/-3 Hz
  - 480 V +/-10% 3~, 60 Hz +/-3 Hz
- Voltage range for systems with the Fluoro UPS:
  - 380 V +/-10% 3N~, 50 Hz or 60 Hz +/-3 Hz
  - 400 V +/-10% 3N~, 50 Hz or 60 Hz +/-3 Hz
  - 415 V +/-10% 3N~, 50 Hz or 60 Hz +/-3 Hz
  - 480 V +/-10% 3N~, 60 Hz +/-3 Hz

### 5.4.2.2 Breakers

The MDP shall provide a main breaker at its input, its specifications shall be:

- Current Rating: 100 A.
- It shall be capable of withstanding an inrush current of 2000 A for 10 ms.
- The voltage rating shall be the MDP nominal input line voltage +10%: i.e., 380 V + 10%, 400 V + 10%, 415 V + 10% or 480 V +10%.
- The frequency range shall be adapted to the input line frequency i.e., 50 Hz +/-3 Hz or 60 Hz +/-3 Hz.
- The Short Circuit Current Rating (SCCR) shall be adapted to the input line source short circuit capacity.

This command of this breaker shall be accessible from the outside of the MDP, in order to be able to rearm it without opening the MDP after an emergency power off.

For systems with the FUPS, the MDP shall provide a second breaker for protection of the FUPS input. Its specifications shall be:

- 3 poles type
- Voltage rating: same as the MDP main breaker
- Frequency range: same as the MDP main breaker

- Current Rating: 50 A
- Short Circuit Current Rating (SCCR): 50 kA.

For systems with the Fluoro UPS, the breaker for the FUPS input protection shall be powered by the MDP main breaker.

### 5.4.2.3 Terminal Blocks

The MDP shall have an input mains terminal block rated in accordance with the hospital input voltage. It shall be capable of holding minimum 35 mm<sup>2</sup> cable for the 3 phases, protective Earth and neutral (only for systems with the Fluoro UPS).

The MDP shall provide an output terminal block rated in accordance with the MDP input voltage to connect the output from the MDP main breaker to the system. This terminal block shall be capable of holding minimum 35 mm<sup>2</sup> cable for the 3 phases.

For systems with the Fluoro UPS, the MDP shall have a terminal block to connect an input neutral from the mains and an output neutral to the Fluoro UPS, and it shall have an output terminal block rated to the hospital input voltage to connect the mains input power from the MDP to the FUPS. This terminal block shall be capable of holding minimum 10 mm<sup>2</sup> cable for the 3 phases and neutral.

### 5.4.2.4 Protective Earth

The MDP shall have a ground bar / ground terminal to connect the protective Earth cables:

- from the hospital mains,
- to the system,
- to the FUPS (if present).

### 5.4.2.5 Indicators

The MDP shall have lights to indicate the presence of voltage. The presence of voltage on each input line shall be indicated by at least having lamps between Line1-Line2 and Line2-Line3. The recommended color for these lamps is green.

## 5.4.3 Mandatory EPO Requirements

The MDP shall provide an emergency power off (EPO) button on its front.

The EPO button shall not be of momentary type.

The EPO button shall have 2 NC contacts:

- one NC contact is to trip the MDP input breaker,
- the other NC contact is to activate the UPS EPO input (1 kVA or 8 kVA or FUPS) to turn off the UPS output (this connection is done inside the PDU).

The MDP shall provide a terminal block to connect external cables to the 2 NC contacts of the MDP EPO.

When the MDP EPO or the PDU EPO is pressed, the MDP shall not provide any output voltage without any additional action on the EPO buttons and on the MDP input breaker.

The EPO button shall be protected against accidental activation, in order to prevent from accidental power OFF as shown below or equivalent.

**Figure 116 EPO Button**



#### 5.4.4 Mandatory LOTO Requirements

The MDP shall provide means of disconnecting the mains power from the system, with LOTO capability to ensure safe service operation. It can be done by the input breaker if it has disconnecting capability, or by a separate disconnection device.

An operator should be able to apply LOTO without opening the MDP box. When a LOTO device is installed on the MDP input breaker or on the disconnecting device, there shall be no voltage at the output of the MDP.

#### 5.4.5 Cabling Requirements

It is the customer's responsibility to ensure that the electrical installation is compliant with local regulations, such as NFPA99 (Health Care Facilities Code) or 60364-7-710 (Requirements for special installations or locations - Medical locations).

The power supply and ground cables shall be dedicated to the system. They must not be used to supply other systems. Power supply and ground cables shall be kept separated from other room System cables and must be connected to the same distribution panel. They must run near one to the other.

The power cables, ground cables and EPO cables provided by the customer shall be compliant with local regulations (e.g. UL, NFPA 70, CSA, IEC, CCC).

##### 5.4.5.1 Power Cables

The minimum gauge of the power cables at the MDP input and between the MDP and the PDU shall be 35 mm<sup>2</sup> / 2 AWG (cables # 1 and # 2 on [Figure 111 on page 154](#) and [Figure 112 on page 155](#)).

The length of the cable between MDP and PDU (cable # 2) shall be in accordance with [Table 35 on page 164](#) and to the impedance definition in [5.1 System Electrical Ratings on page 153](#). This cable shall be copper cable and cable insulation temperature shall be 90°C. Use cable Type S for North America.

The minimum gauge of the power cables from the MDP to the FUPS and from the FUPS to the PDU shall be 10 mm<sup>2</sup> / 6 AWG (cables # 3 and # 4 on [Figure 112 on page 155](#)).

The insulation temperature of these power cables shall be 90°C minimum.

### 5.4.5.2 Protective Earth Cables

To avoid risk of electric shock, this equipment must only be connected to a mains power supply with Protective Earth.

The gauge and type of the protective Earth cables (cables #1, #3 and #4) shall be the same as the MDP's.

The cable between the MDP and the PDU (cable #2) shall be in accordance with the table below, and shall be separate from the power cables.

**Table 35**

Length	Gauge
< 6 m	1 x 35 mm <sup>2</sup> - 1 x 2 AWG
< 15.1 m	2 x 35 mm <sup>2</sup> - 2 x 2 AWG

### 5.4.5.3 EPO Cable

The hospital shall provide an EPO cable between the MDP and the PDU; its minimum gauge shall be 1 mm<sup>2</sup> and shall be in accordance with the rating of the fuse F2 of the MDP.

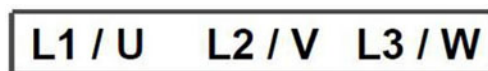
A 12 m EPO cable between the PDU and the Fluoro UPS is provided with the system. If a longer cable is needed, it shall be provided by the hospital, its minimum gauge shall be 1 mm<sup>2</sup>.

### 5.4.5.4 Fluoro UPS Ethernet Cable

A 6 m Ethernet cable between the C-FRT Cabinet and the Fluoro UPS is provided with the system. If a longer cable is needed, it shall be provided by the hospital; it shall be Cat5 minimum.

## 5.4.6 Mandatory Labeling Requirements

The input mains terminal block and the output terminal blocks of the MDP shall be labeled to indicate the 3 lines as shown below or equivalent:



For systems with the Fluoro UPS, the MDP input neutral terminal block and the neutral output terminal block to the Fluoro UPS shall be labelled with the IEC 60445 symbol as shown below or equivalent:



The ground bar shall be marked with the IEC 60417-5019 symbol as shown below:



### 5.4.7 Other Mandatory Requirements

The MDP and the external cables shall be compliant to all applicable local regulations, in particular to the standards applicable to Industrial Control Panels or Low-voltage switch gear and control gear assemblies, such as UL508A for USA or IEC 61439-1 for Europe.

The MDP enclosure shall be grounded if its enclosure is metallic, and there shall be no access to hazardous voltages. The enclosure shall provide enough rigidity to avoid hazardous situations in case of shock or impact and shall be designed in accordance with the local regulations.

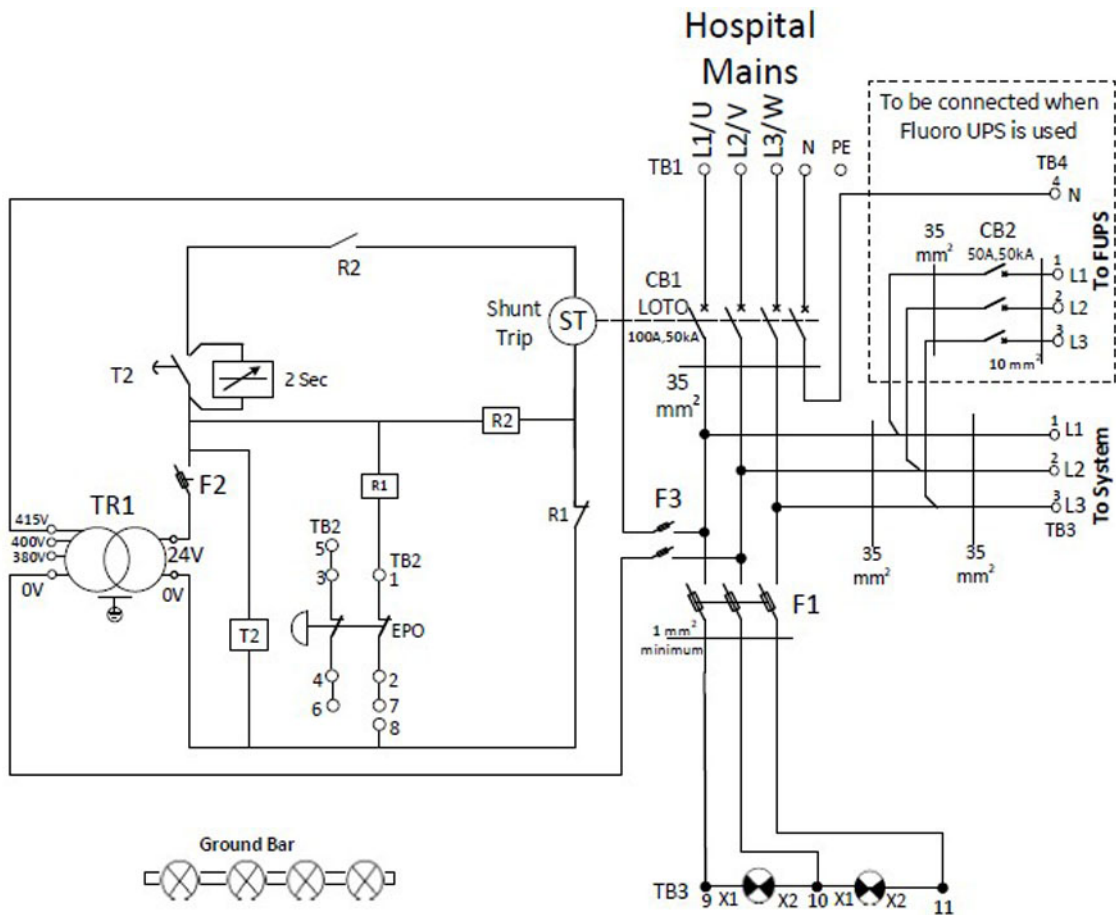
Local regulation may require the MDP to have a door interlock mechanism to prevent from opening the door when the main breaker is on.

The MDP shall be provided with a LOTO procedure.

### 5.4.8 Preferred Schematics and Components

#### 5.4.8.1 Recommended CE Schematics

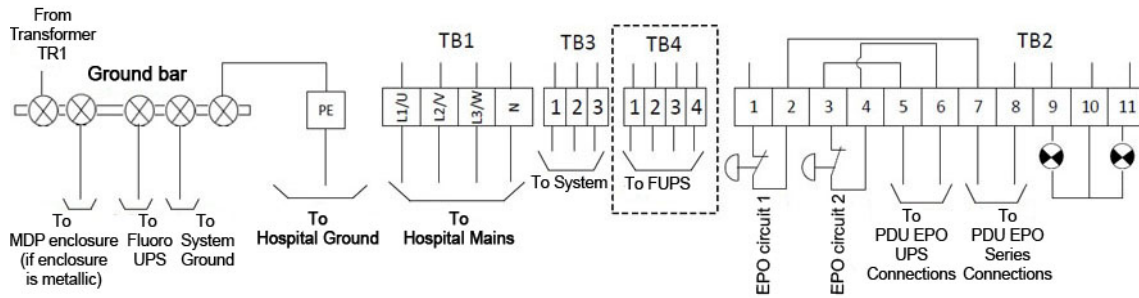
Figure 117 CE MDP - Power and Control



**NOTE**

Neutral is not required by Imaging system.  
 Neutral is required when Fluoro UPS is used.

**Figure 118 CE MDP - I/O Interfaces**



**5.4.8.2 Minimum Components Specifications for the CE MDP**

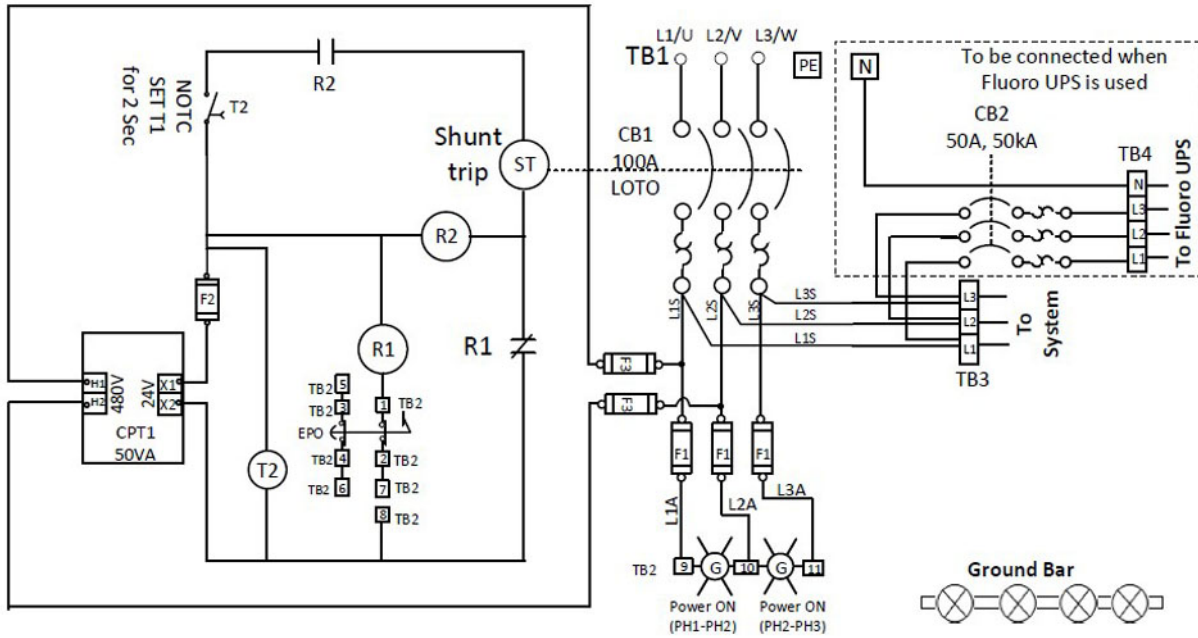
**Table 36**

Component	Label (refer to Figure 117 on page 165)	Rating
Input Circuit Breaker	CB1	4 Pole, 100A, 50 kA, Vin + 10% 50 Hz or 60 Hz 2000 A inrush current withstand capability for at least 10 ms
Circuit Breaker	CB2	50 A, 50 kA, Vin+ 10%, 50 Hz or 60 Hz
Fuse	F1	2A Time delay, Vin+10% Based on green indicator lights power ratings
Fuse	F2	2A, 24 VAC+10% Based on transformer power rating and transformer load current rating
Fuse	F3	1A Time delay, Vin+10% Based on transformer power rating and transformer input current
Time delay relay	T2	24 VAC+10% Shall have 1 NO contact Time delay setting shall be min 2 Sec

continued		
Component	Label (refer to Figure 117 on page 165)	Rating
Auxiliary relay	R1, R2*	24 VAC+10% Shall have 1 NC contact, 1 NO contact * R1 and R2 part numbers shall be identical (same manufacturer, same reference) Preferred components for R1 and R2 relay are: <ul style="list-style-type: none"> <li>• <b>GE:</b> PRC1S13-BDL</li> <li>• <b>ABB:</b> CR-M024AC2L</li> <li>• <b>Schneider Electric:</b> 782XBXM4L-24A</li> <li>• <b>Omron:</b> MK2PI</li> </ul>
Shunt Trip	ST	24 VAC+10% Shunt trip opens the MDP input main breaker when the shunt trip is energized
2 Pilot lights Green	-	Vin+10%, 50 Hz or 60 Hz
Transformer	TR1	Power rating: 50 VA or based on power ratings of components used at transformer output Input: 380 VAC or 400 VAC or 415 VAC Output: 24V Frequency: 50 or 60 Hz Double insulation as per standard IEC61558 The sum of power ratings of R1, shunt trip and timer shall be less than transformer power rating
EPO	-	Mushroom button with 2 NC contacts Rated for 24 VAC, 50 mA
Cable for MDP internal Control circuitry	-	Min 1 mm <sup>2</sup> and in accordance with the fuses rating

### 5.4.8.3 Recommended UL Schematics

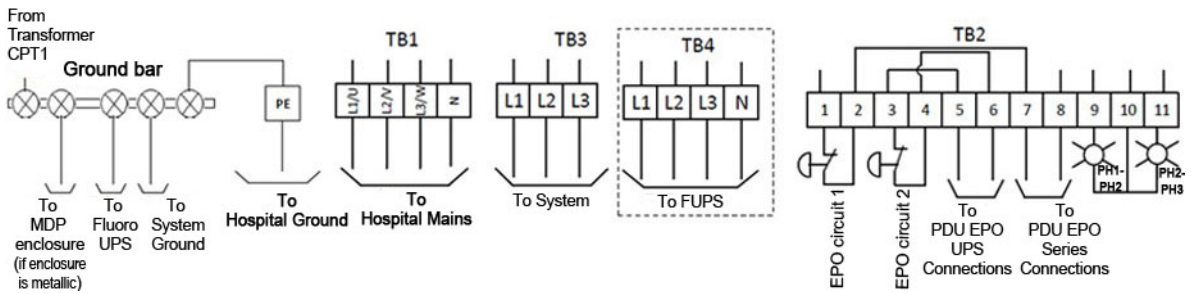
Figure 119 UL MDP - Power and Control



**NOTE**

Neutral is not required by Imaging system.  
 Neutral is required when Fluoro UPS is used.

Figure 120 UL MDP - I/O Interfaces



### 5.4.8.4 Minimum Components Specifications for the UL MDP

**Table 37**

Component	Label (refer to Figure 119 on page 168)	Rating
Input Circuit Breaker	CB1	3 Pole, 100 A, 50 kA, 480 VAC+10% 60 Hz 2000 A inrush current withstand capability for at least 10 ms
Circuit Breaker	CB2	50 A, 50 kA, 480 VAC+10% 60 Hz
Fuse	F1	2A Time delay, 480 VAC+10% Based on green indicator lights power ratings
Fuse	F2	2A, 24 VAC+10% Based on transformer power rating and transformer load current rating
Fuse	F3	1A Time delay, 480 VAC+10% Based on transformer power rating and transformer input current
Time delay relay	T2	24 VAC+10% Shall have 1 NO contact Time delay setting shall be min 2 s
Auxiliary relay	R1, R2*	24 VAC+10% Shall have 1 NC contact, 1 NO contact * R1 and R2 part numbers shall be identical (same manufacturer, same reference) Preferred components for R1 and R2 relay are: <ul style="list-style-type: none"> <li>• <b>GE:</b> PRC1S13-BDL</li> <li>• <b>ABB:</b> CR-M024AC2L</li> <li>• <b>Schneider Electric:</b> 782XBXM4L-24A</li> <li>• <b>Omron:</b> MK2PI</li> </ul>
Shunt Trip	ST	24 VAC+10% Shunt trip shall open the MDP input breaker when shunt trip is energized
2 Pilot lights Green	PH1-PH2 PH2-PH3	480 VAC +10%

continued		
Component	Label (refer to Figure 119 on page 168)	Rating
Transformer	CP T1	Power rating: 50 VA or based on power ratings of components used at transformer output Input: 480 VAC Output: 24 VAC Frequency: 60 Hz +/- 3 Hz Double insulation as per UL 5085-1 standard The sum of power ratings of R1, shunt trip and timer shall be less than transformer power rating
EPO	-	Mushroom button with 2 NC contacts Rated for 24 VAC, 50 mA
Cable for MDP internal Control circuitry	-	Min 16 AWG and in accordance with the fuses rating

### 5.4.9 Checklist

The following checklist shall be filled and given to the Field Engineer before connecting the MDP to the system.

**Table 38**

Test	Expected Result	OK / NOK
Functional Tests		
Initial state: the MDP main breaker is off, power is available at its input. A jumper is installed between TB2 7 & 8 Turn on the MDP main breaker.	The indicator lights on MDP front panel are ON.	
	The voltage at TB3 is the same as the MDP input voltage.	
	For systems with the FUPS, the voltage at TB4 is the same as the MDP input voltage.	
Press the EPO push button on MDP front panel.	The indicator lights on the MDP front panel are turned off.	
	The MDP main breaker is opened.	
	There is no voltage at TB3.	
	For systems with the FUPS, there is no voltage at TB4.	
	The dry contact between TB2 5 & 6 is open.	

continued		
Test	Expected Result	OK / NOK
Check it is possible to apply the LOTO on the MDP input breaker or on the disconnecting device.	It is possible to apply the LOTO on the MDP input breaker or on the disconnecting device.	
Documentation		
Check a LOTO procedure is provided with the MDP.	The LOTO procedure is present.	
Components Ratings		
Check that the components ratings are compliant with the requirements of <a href="#">Minimum Components Specifications for the CE MDP on page 166</a> or <a href="#">Minimum Components Specifications for the UL MDP on page 169</a> .	The components ratings are compliant with the requirements of <a href="#">Minimum Components Specifications for the CE MDP on page 166</a> or <a href="#">Minimum Components Specifications for the UL MDP on page 169</a> .	

## 5.5 External Interfaces

### 5.5.1 Emergency Power Off (EPO)

The PDU is provided with an EPO button on its front panel and provides the connection for additional EPO buttons (in Exam Room or Control Room).

The customer is responsible for the procurement, delivery and installation of the cables and EPO buttons.

The EPO buttons shall provide 2 Normally Closed contacts, compatible with 24 V AC and in accordance with the MDP transformer rating. The maximum length of the cables shall be 24 m, the recommended diameter is 17 AWG/1 mm<sup>2</sup>.

Once activated, the EPO button shall require a user action to deactivate it (for instance "Push to activate - Push to release" or lever type).



THE POSITION OF THE ADDITIONAL EPO BUTTONS IN THE EXAM ROOM AND CONTROL ROOM SHALL ALLOW TO MINIMIZE ACCIDENTAL ACTIVATION BY A USER, SHOCK WITH A GURNEY... THE EPO BUTTON SHALL BE PROTECTED AGAINST ACCIDENTAL ACTIVATION (SEE EXAMPLE BELOW)



Legend of Figure 121 on page 173 and Figure 122 on page 173:

Item	Description
	Black line: Internal wiring
	Red line: External wiring (Customer responsibility)
[1]	Remote EPOs
[2]	UPS EPO
[3]	PDU
[4]	PDU EPO
[5]	PDU Transformer temperature sensor
[6]	MDP
[7]	MDP EPO
[8]	MDP EPO internal circuit

Figure 121 EPO Schematic with 1 kVA or 8 kVA UPS

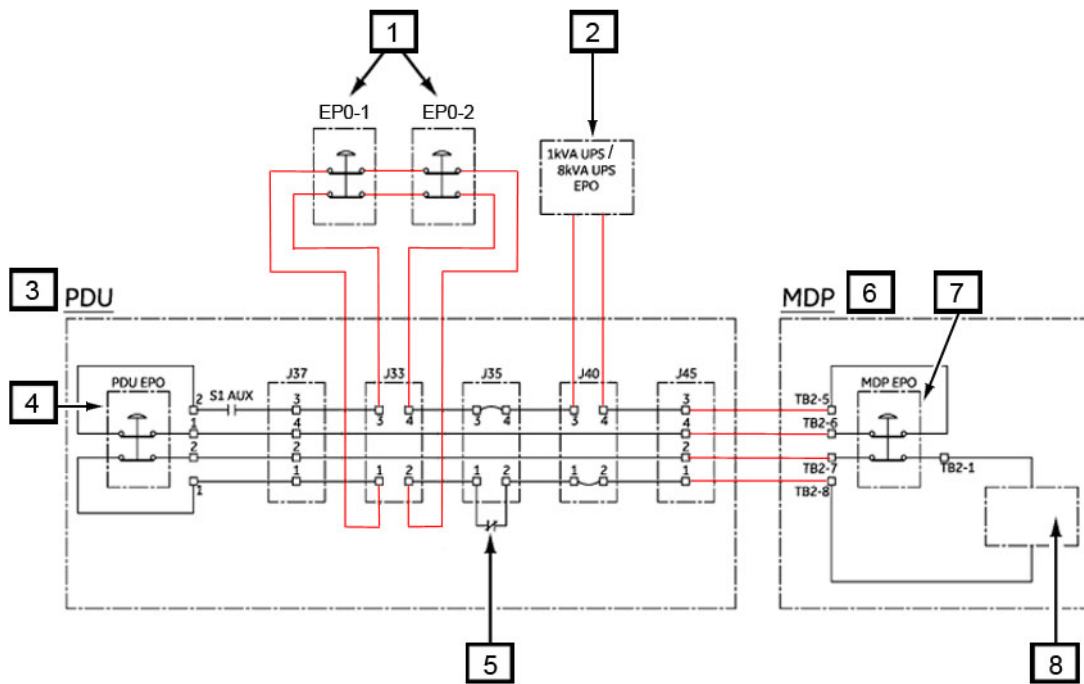
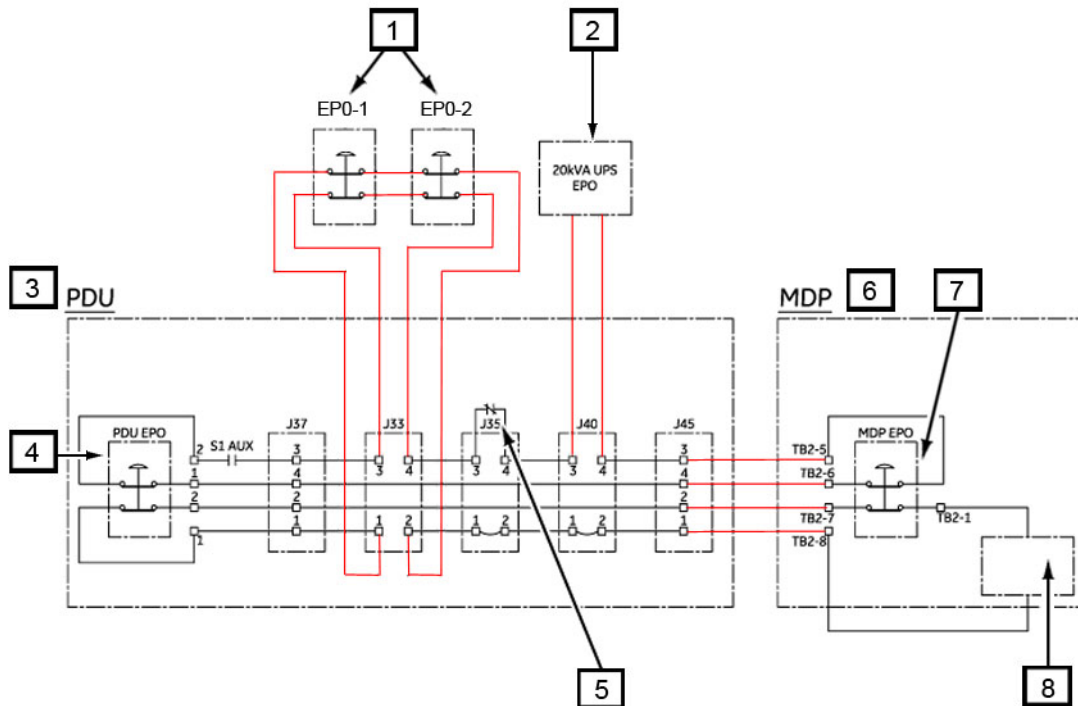


Figure 122 EPO Schematic with Fluoro UPS 20 kVA



**NOTE**

J35 connection:

- UPS 1 kVA: pair 1, 2 connected to Transformer EPO output, pair 3, 4 is shorted.
- UPS 8 kVA: pair 1, 2 connected to Transformer EPO output, pair 3, 4 is shorted.
- UPS 20 kVA (Fluoro UPS): pair 3, 4 connected to Transformer EPO output, pair 1, 2 is shorted.

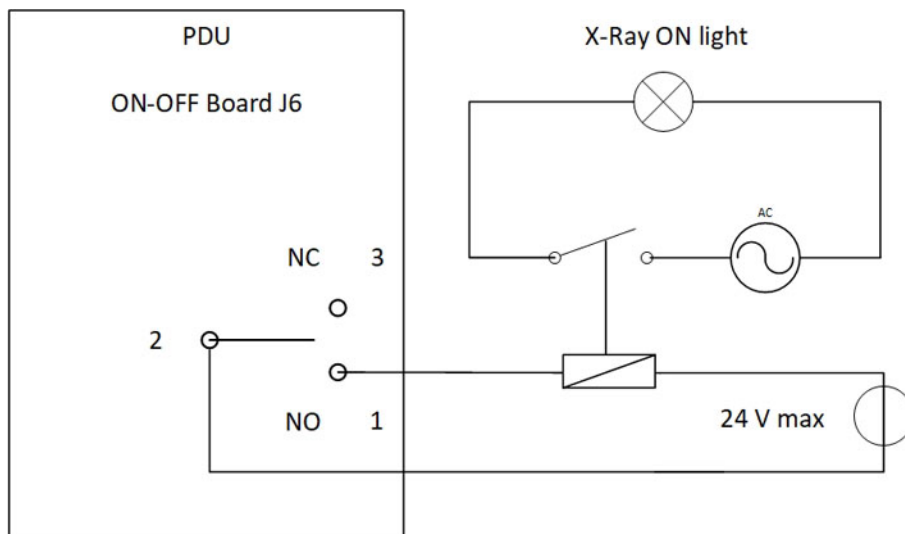
### 5.5.2 X-Ray ON lights



**NOTICE**

The X-Ray ON lamp must be installed in the Exam Room in conformity to the standard IEC/EN 60601-2-43. The X-Ray ON lamp shall be visible by the operator in all the locations defined for the personnel who may receive scattered radiation.

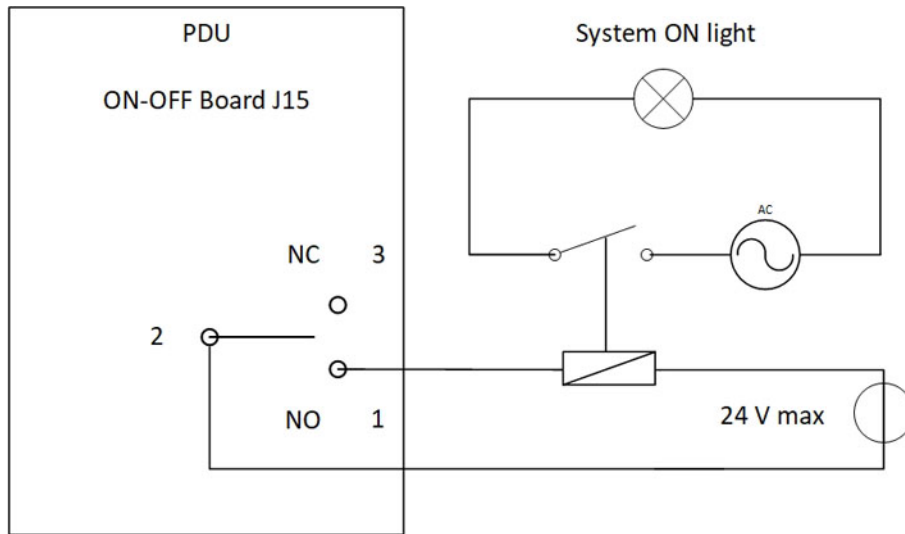
The system provides a dry contact to trigger a low voltage relay (24 V max) that drives the X-Ray ON lights. The customer is responsible for the procurement, delivery and installation of the power supplies, relay, cables and the X-Ray ON lights.



The cables are connected to the PDU on an open contact. The diameter of the cables shall be 2 mm<sup>2</sup> maximum.

### 5.5.3 System ON light

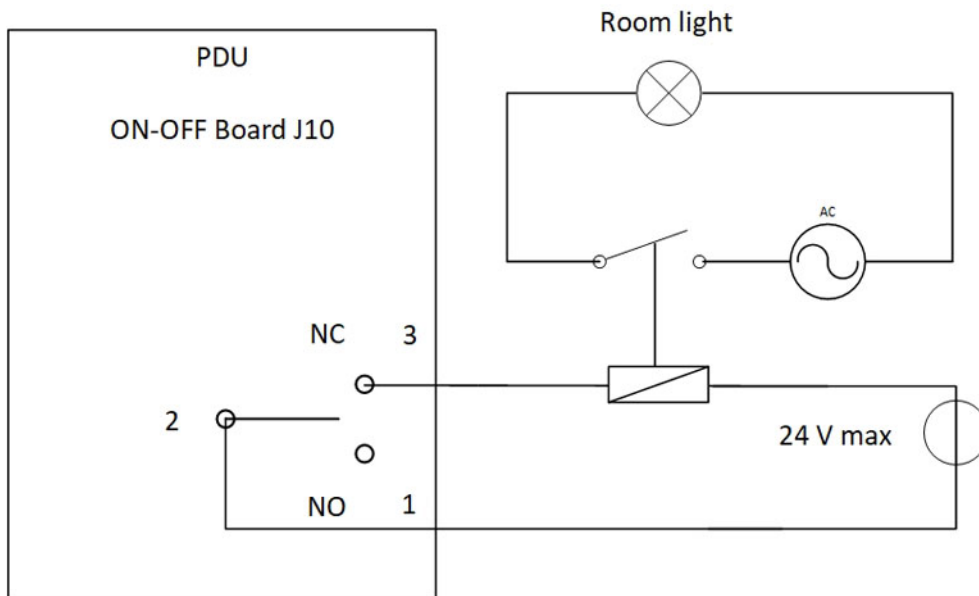
The system provides a dry contact to trigger a low voltage relay (24 V max) that can drive a System ON light. The customer is responsible for the procurement, delivery and installation of the power supplies, relay, cables and the System ON light.



The cables are connected to the PDU on an open contact. The diameter of the cables shall be 2 mm<sup>2</sup> maximum.

### 5.5.4 Room lights

The system provides a dry contact to trigger a low voltage relay (24 V max) that can drive the Exam Room lights. The customer is responsible for the procurement, delivery and installation of the power supplies, relay, cables and the room lights.



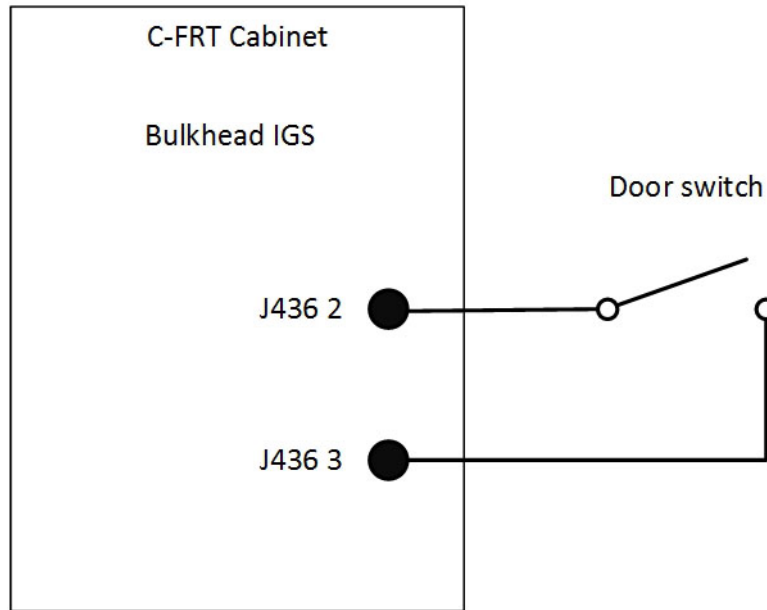
The cables are connected to the PDU on a closed contact. The diameter of the cables shall be 2 mm<sup>2</sup> maximum.

### 5.5.5 Room door interlock

The system provides a room door interlock that can prevent X-Ray emission when the door is open. The IEC 60601-2-43 requires not to install door interlocks. It is the responsibility of the installer to verify that the

connection of this interlock is not in contradiction with local regulation. In case of conflict, the local regulation shall prevail.

This switch shall be closed when the door is closed, it shall be compatible with 24 V DC.

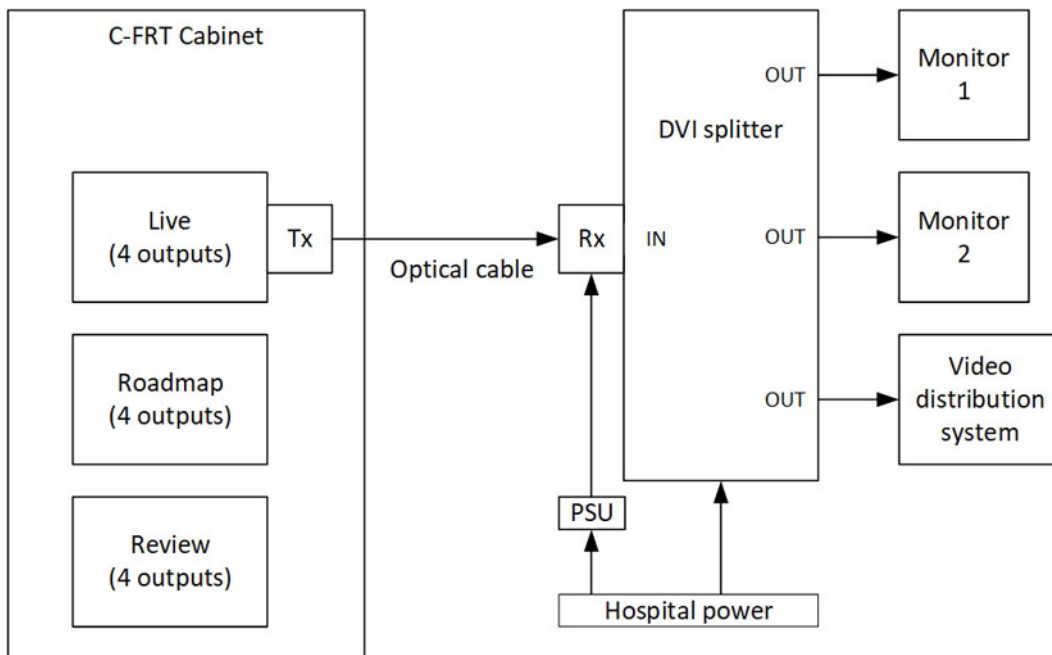


To disable the door interlock: the pins 2 and 3 from J436 shall be shorted. The diameter of the cables connected to the cabinet shall be 2 mm<sup>2</sup> maximum.

### 5.5.6 Video distribution

The system can provide DVI outputs (1280 x 1024, 60 Hz) for each of its 3 displays (live, roadmap and review). Only 4 streams of each display can be provided (including the images displayed on the LDM). These video links are 36 meters optical cables. The power supply (PSU) of the optical receiver (Rx) shall not be powered by the system.

In case more than 4 video streams of a display are needed, additional DVI video splitters and DVI cables shall be provided and installed by the customer as on schematic below. These splitters shall not be installed inside the cabinets, nor be powered by the system.



With the LDM option, a 2MP copy of the LDM image (DVI 1920 x 1080, 60 Hz) can be provided as an option, through a 36 m optical cable. The monitor shall be provided and installed by the customer. The monitor and the optical receiver shall not be powered by the system.

### 5.5.7 Other options

**(For USA only)** A purchasable option I-sense (catalog number E4504B) allows the monitoring of the hospital main power line. It is recommended to install this option everywhere RMS and waveform variation events can impact the standard behavior of the system. I-sense is connected to each phase conductor and the ground. An analog telephone line also needs to be line to I-sense.

## 5.6 Third-Party Monitor Suspension Typical Connections

Figure 123 Typical connections for monoplane with 19" monitors

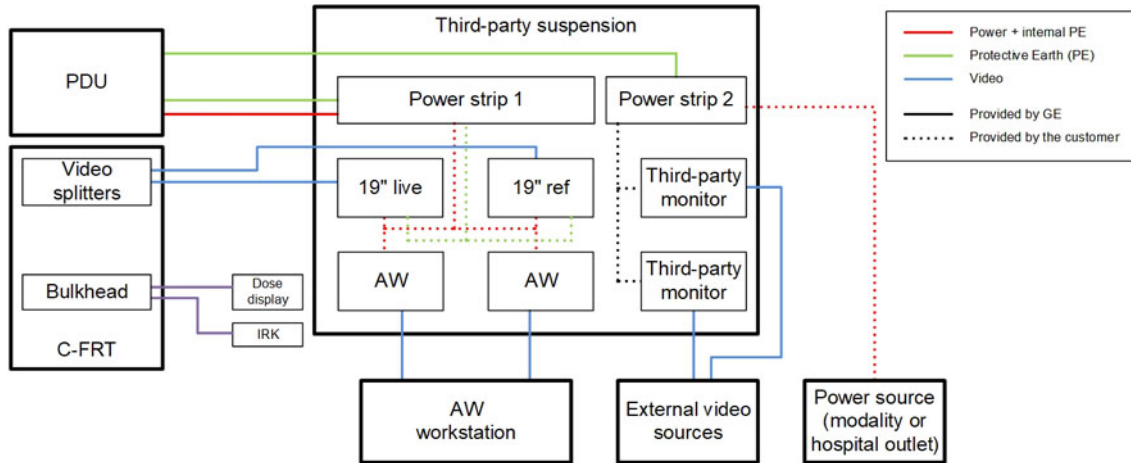
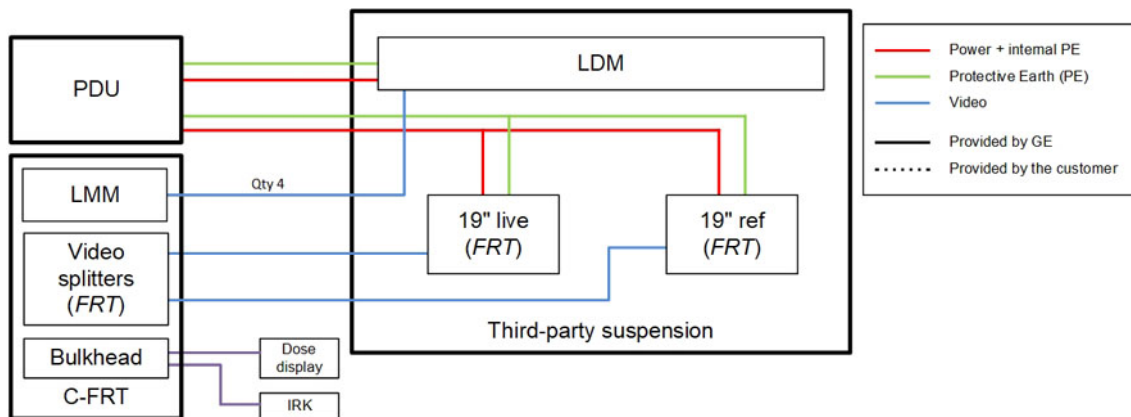
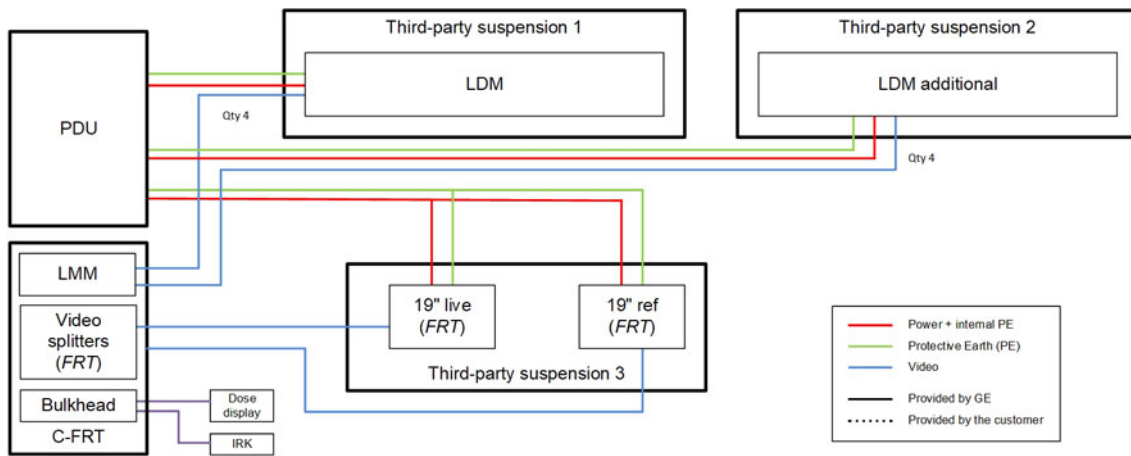


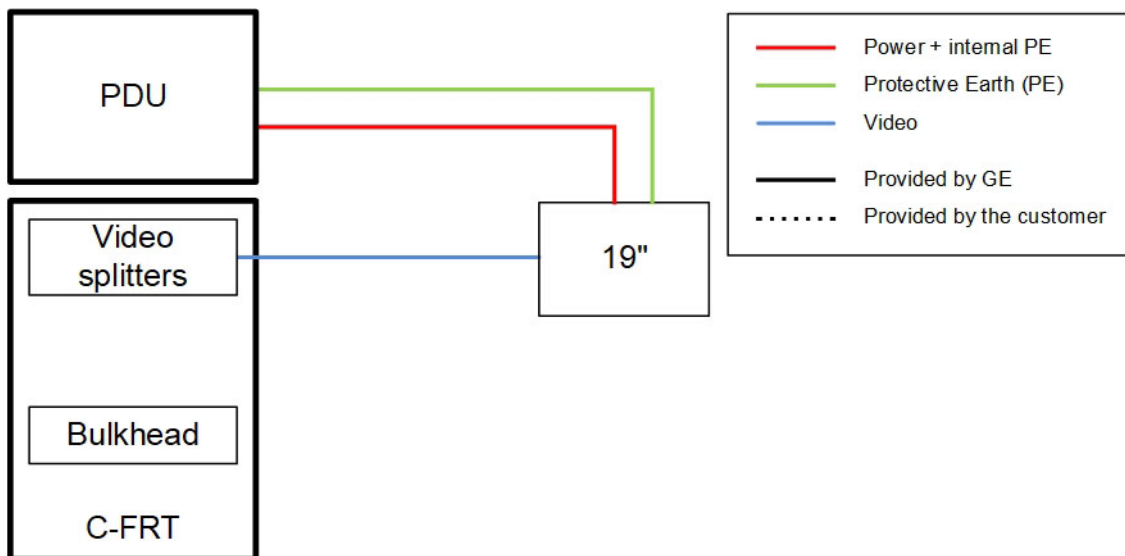
Figure 124 Typical connections for 1 LDM with the 19" backup monitors at the back of the LDM



**Figure 125 Typical connections for 2 LDM with 19" backup monitors on an additional suspension**



**Figure 126 Connection of the additional in-room 19" monitor**

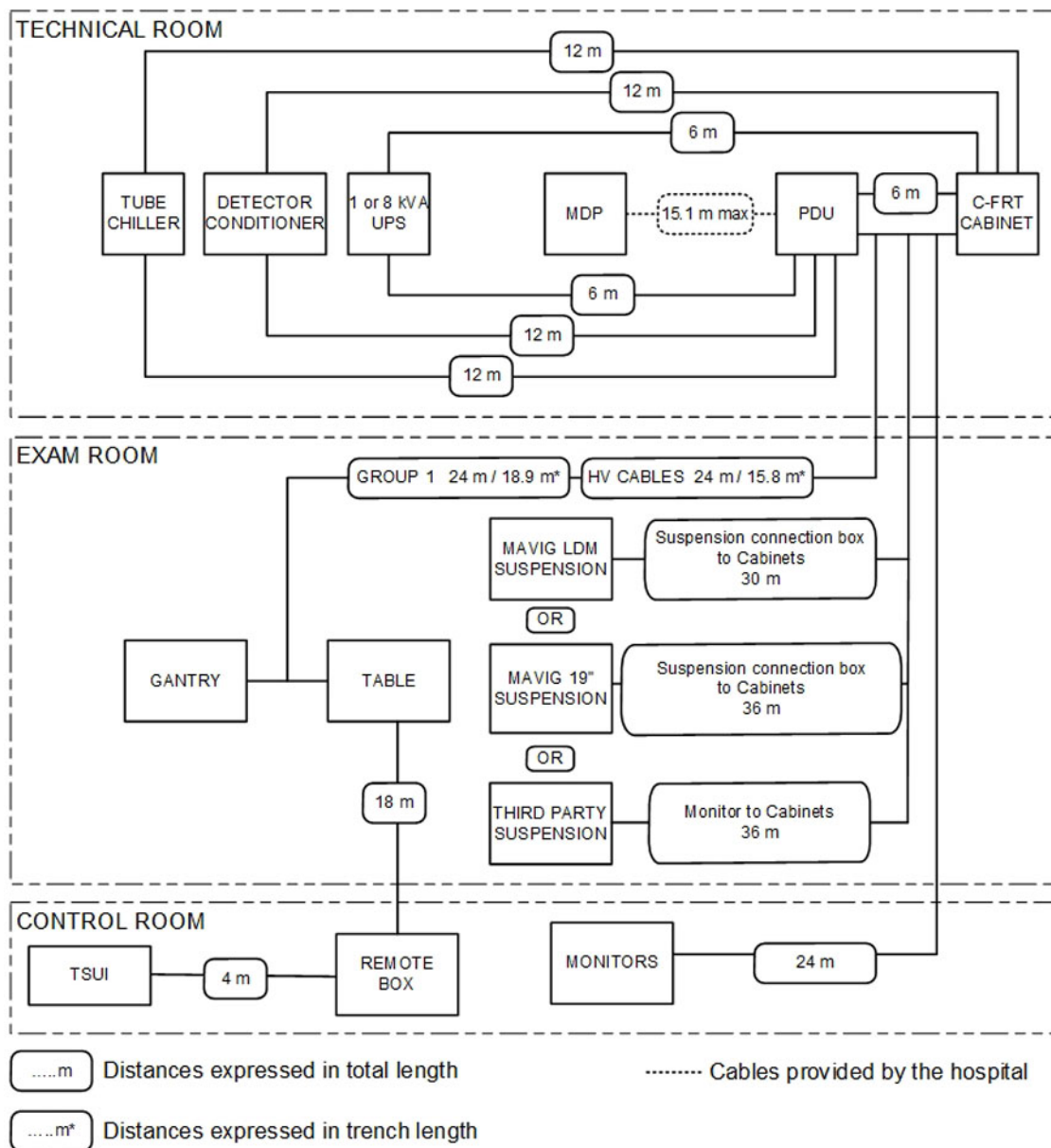


## 5.7 System Cable Information

### 5.7.1 Physical Runs

#### 5.7.1.1 Physical Run Synoptic

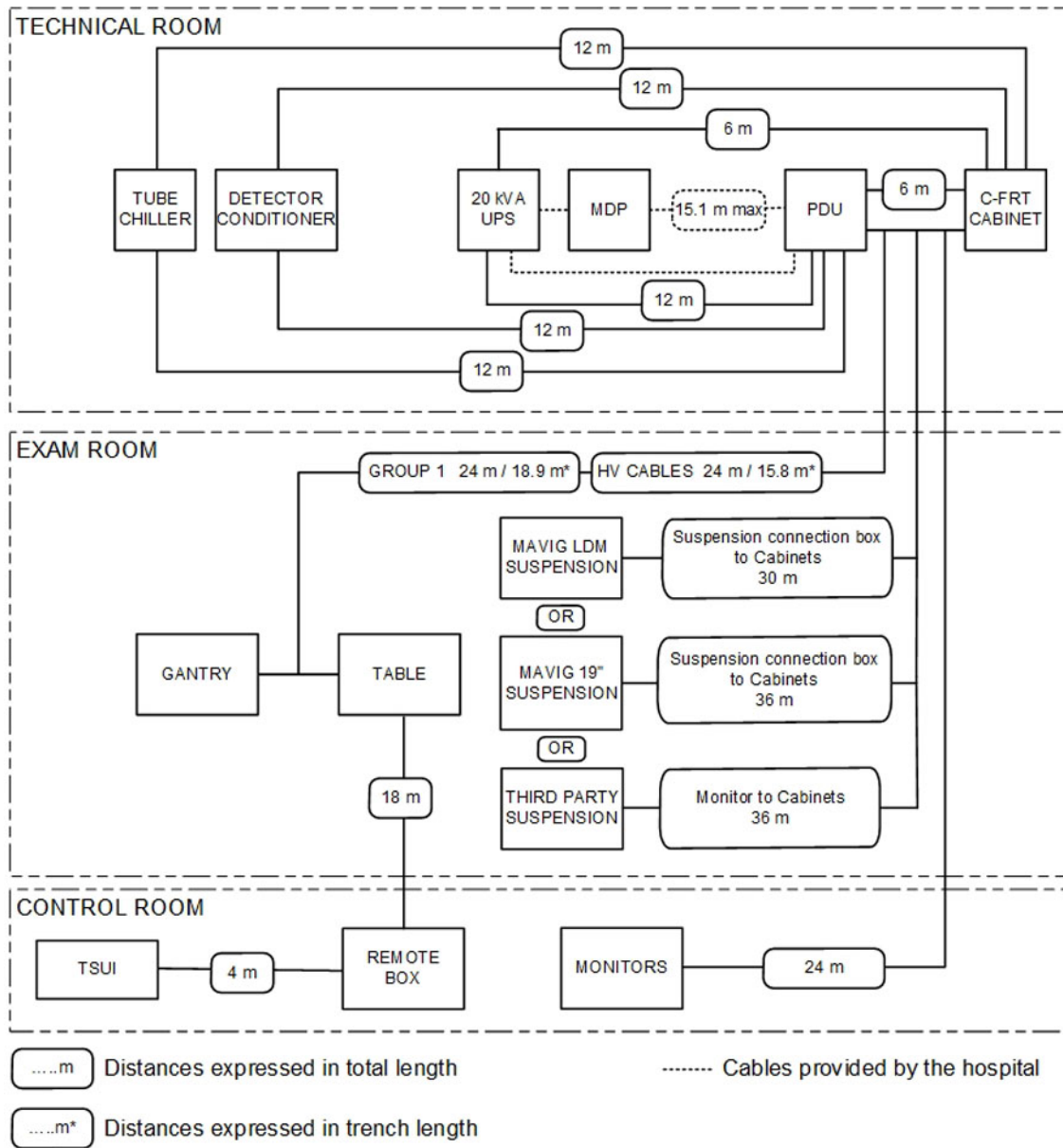
Figure 127 Interconnection Length - System with 1 kVA UPS or 8 kVA UPS



**NOTE**

1 kVA UPS is only provided with Omega Table.

**Figure 128 Interconnection Length - System with 20 kVA UPS (Fluoro UPS)**



### 5.7.1.2 System Core Matrix



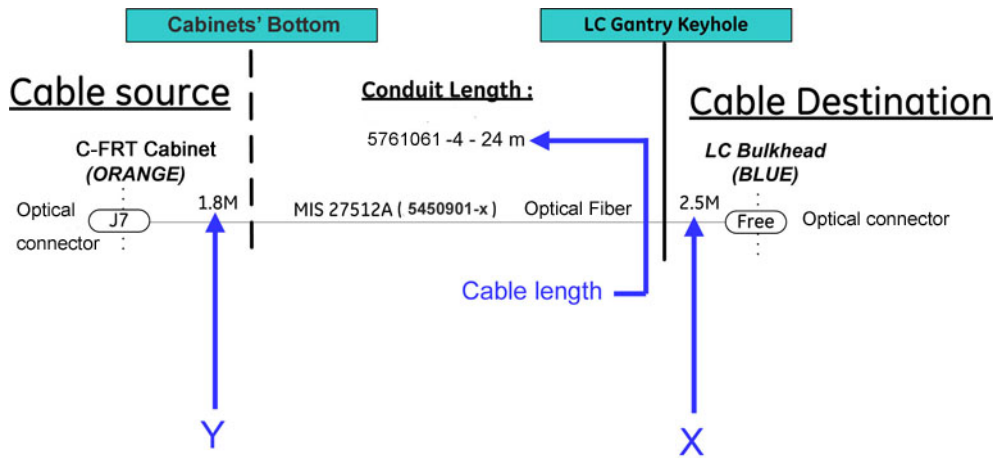
**NOTICE**

All lengths of cable are:

- in useable meter when you look at group level, or
- in meters (connector to connector) when you look at the cable level.

For a description of how to use the following cable group schematics, see below:

**Figure 129 Example of cable group schematic**



Cable length data is as follows:

- **Cable Length** = the total cable length, connector to connector (example above is 24 meters).
- **X + Y** = used length for connection within system (example above is 4.3 meters).
- **Cable Length - (X + Y)** = available length for conduit run (example above is 19.7 meters).

Figure 130 Cable Group 1 and Ground Cable Group - From Technical Room to Exam Room



\*: Omega Table only \*\*; Innova<sup>IQ</sup> / Innova<sup>IO</sup> OR Table only

Figure 131 Cable Group 2 - From Technical Room to Control Room

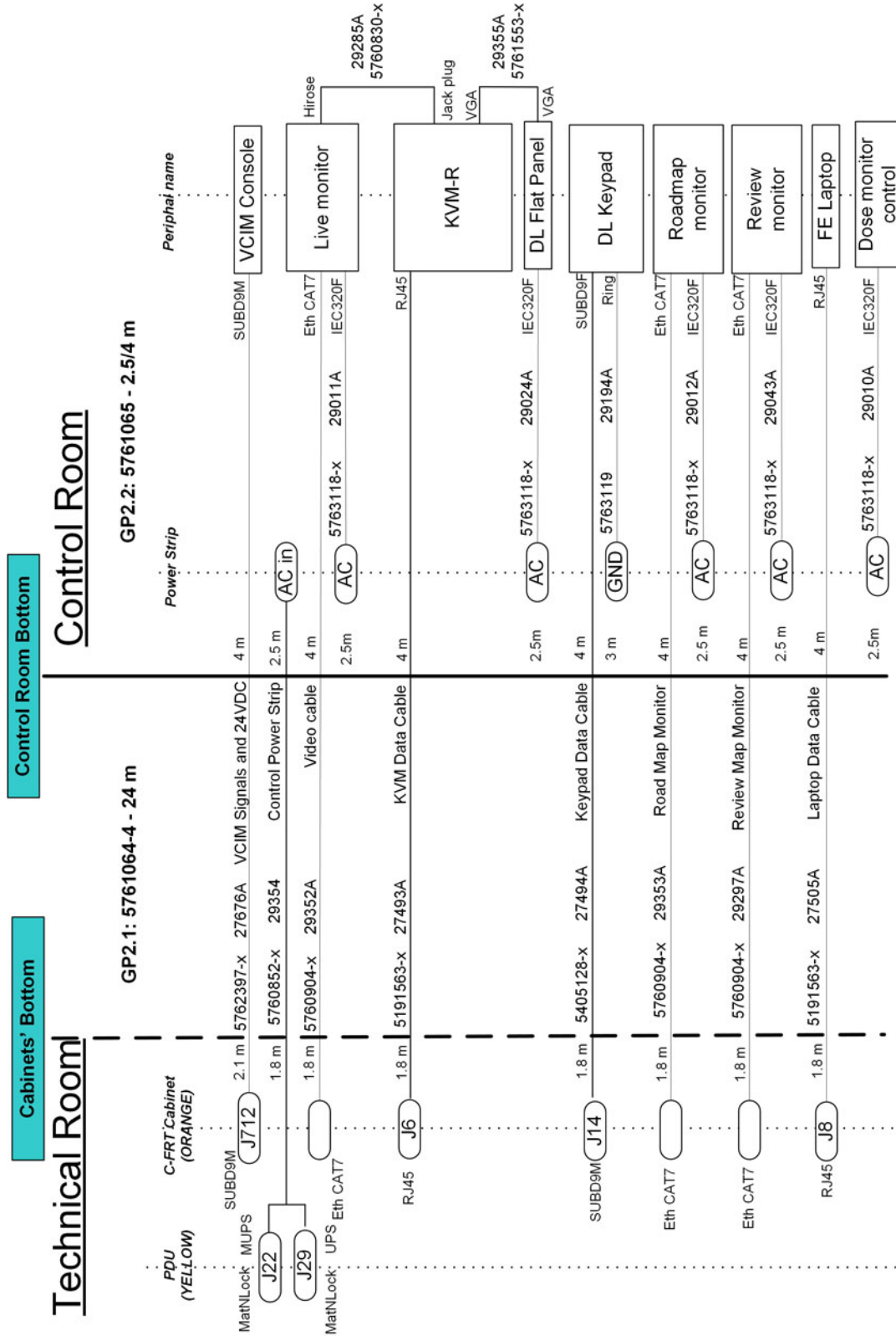


Figure 132 Fast Link Cable Group - Option

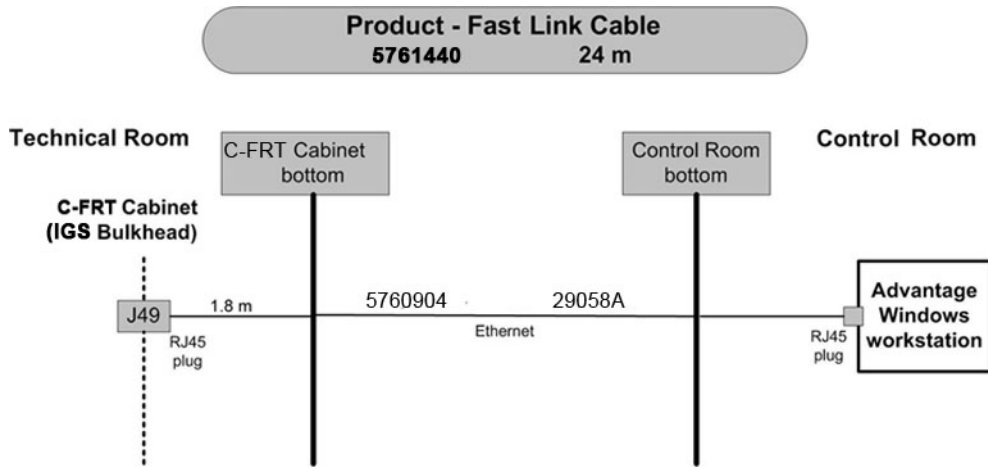


Figure 133 Cable Group 3 - From Technical Room to Technical Room

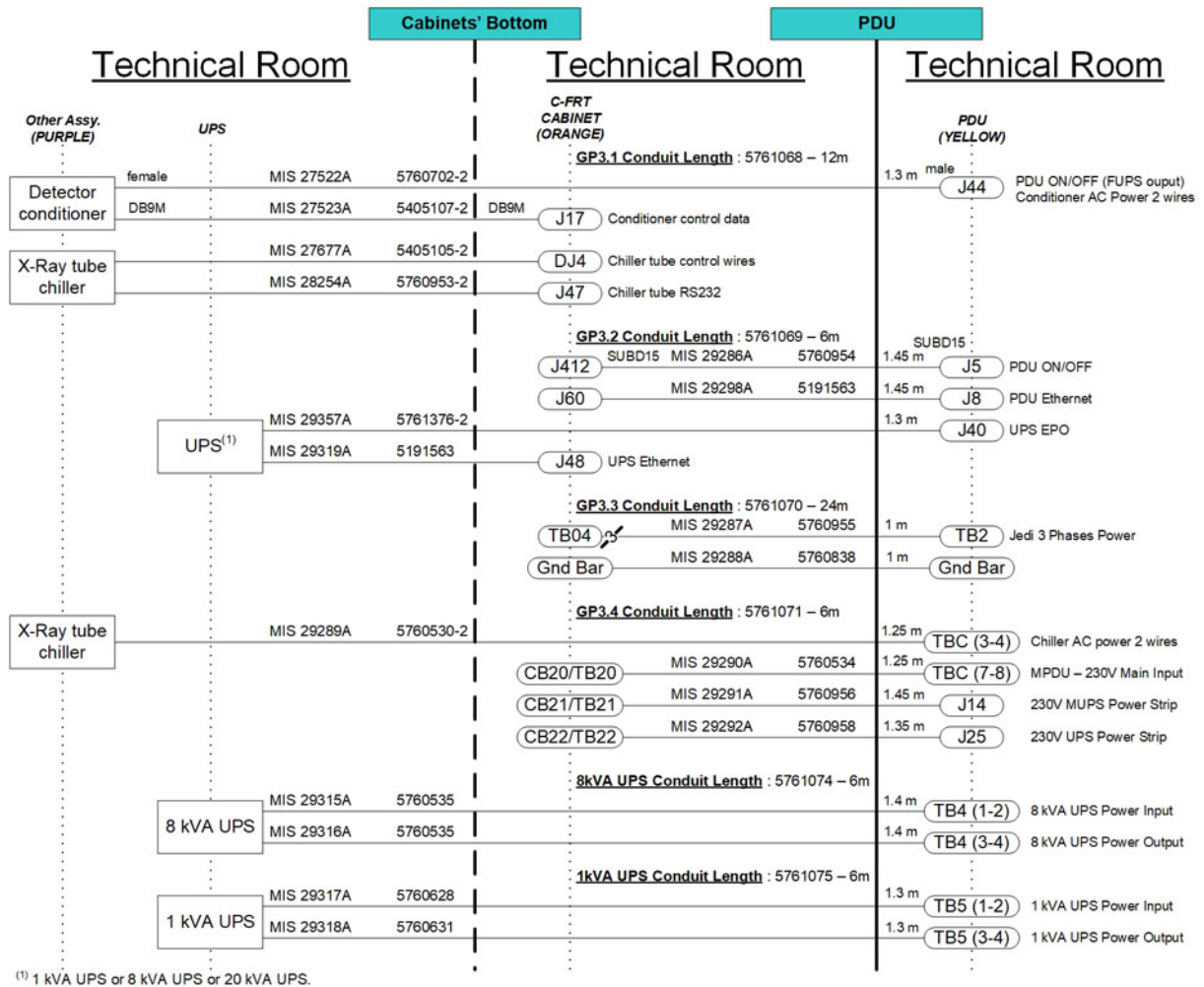


Figure 134 Cable Group 4 – From Technical Room to optional Monitors

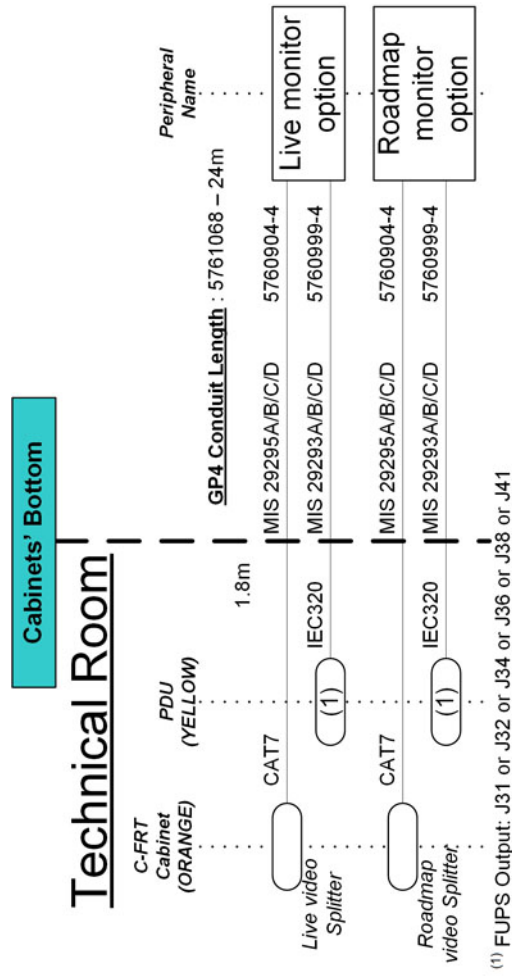




Figure 136 Cable Group - From Technical Room to LDM Mavig Suspension

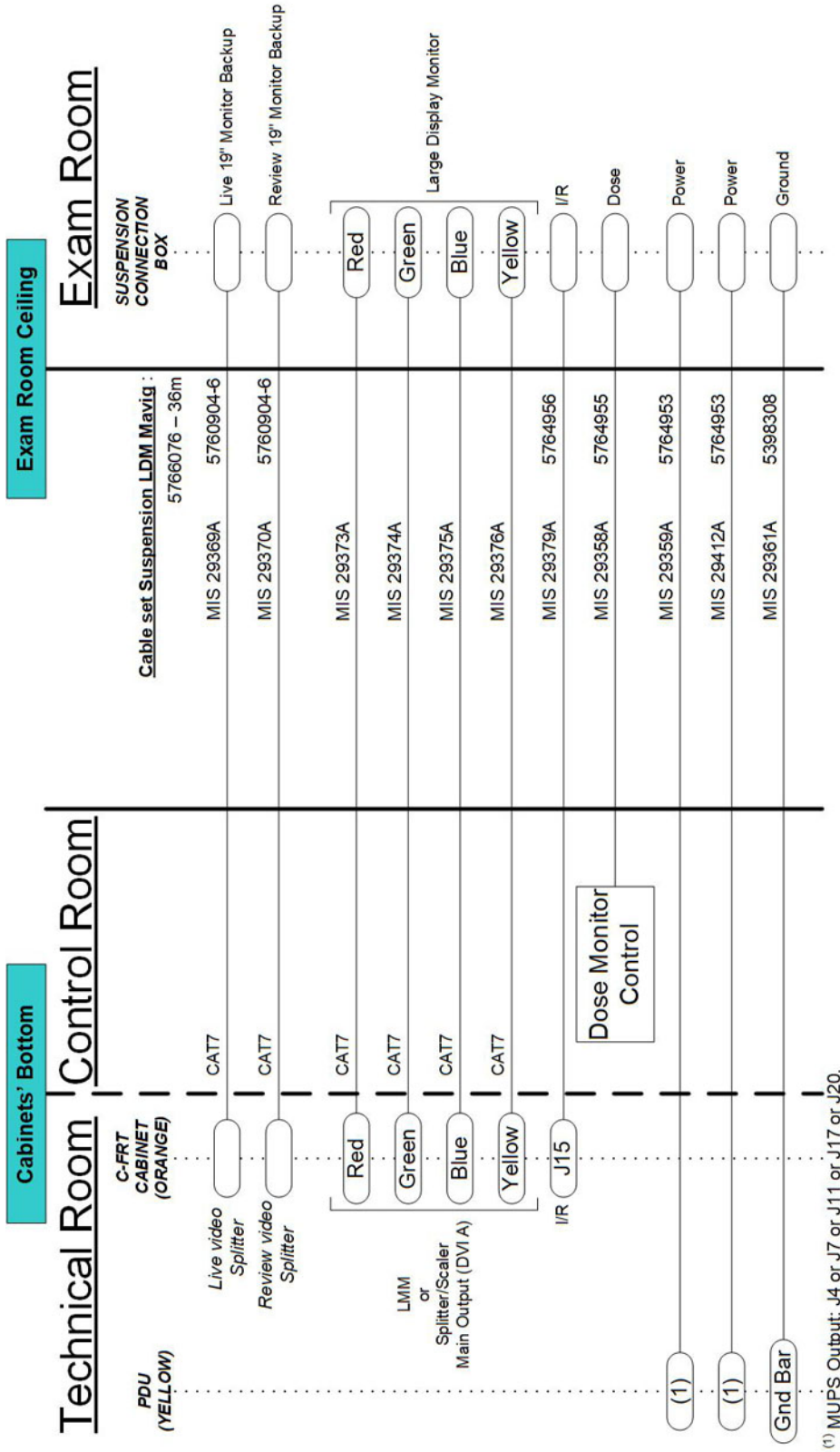


Figure 137 Cable Group - From Technical Room to LDM 3rd Party Suspension

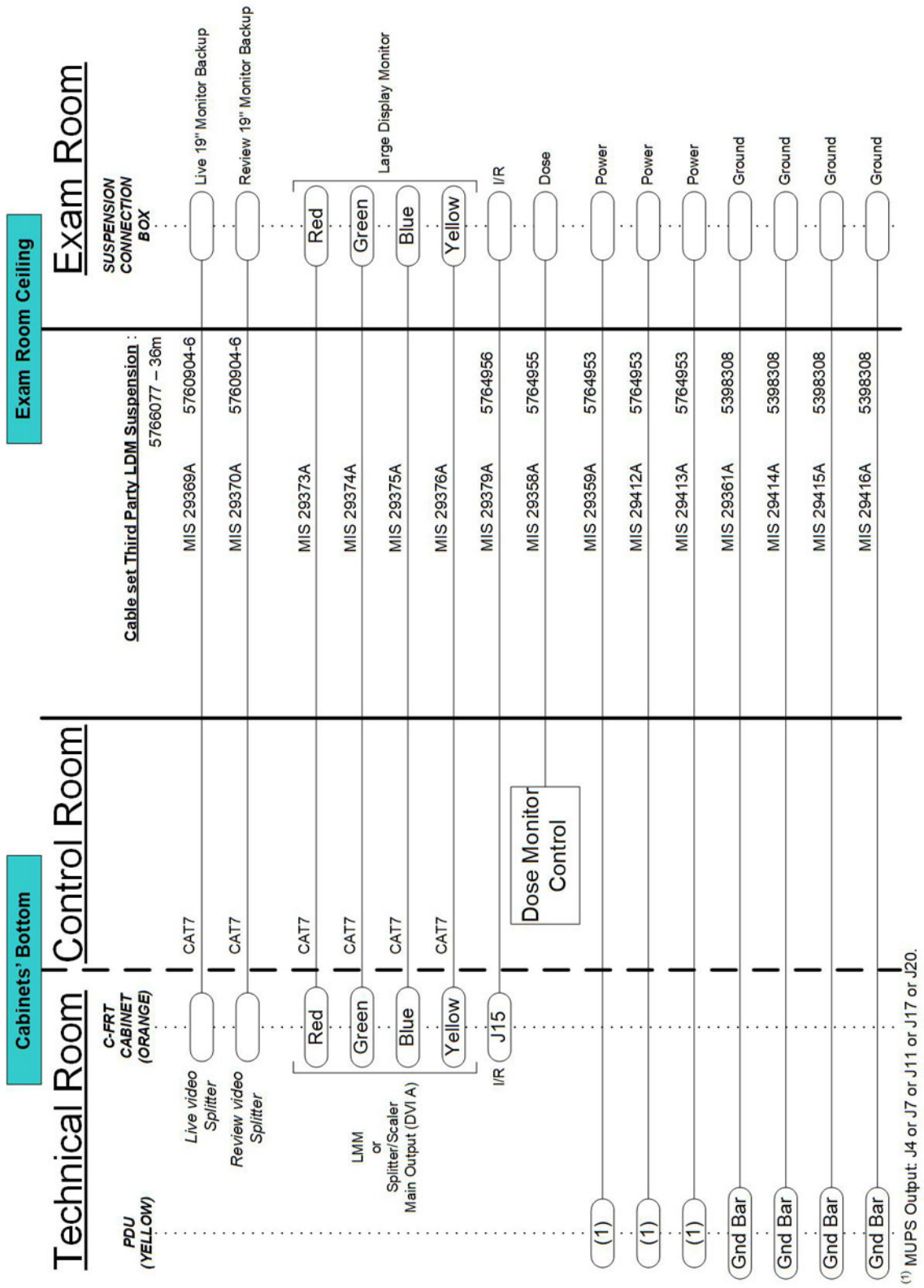
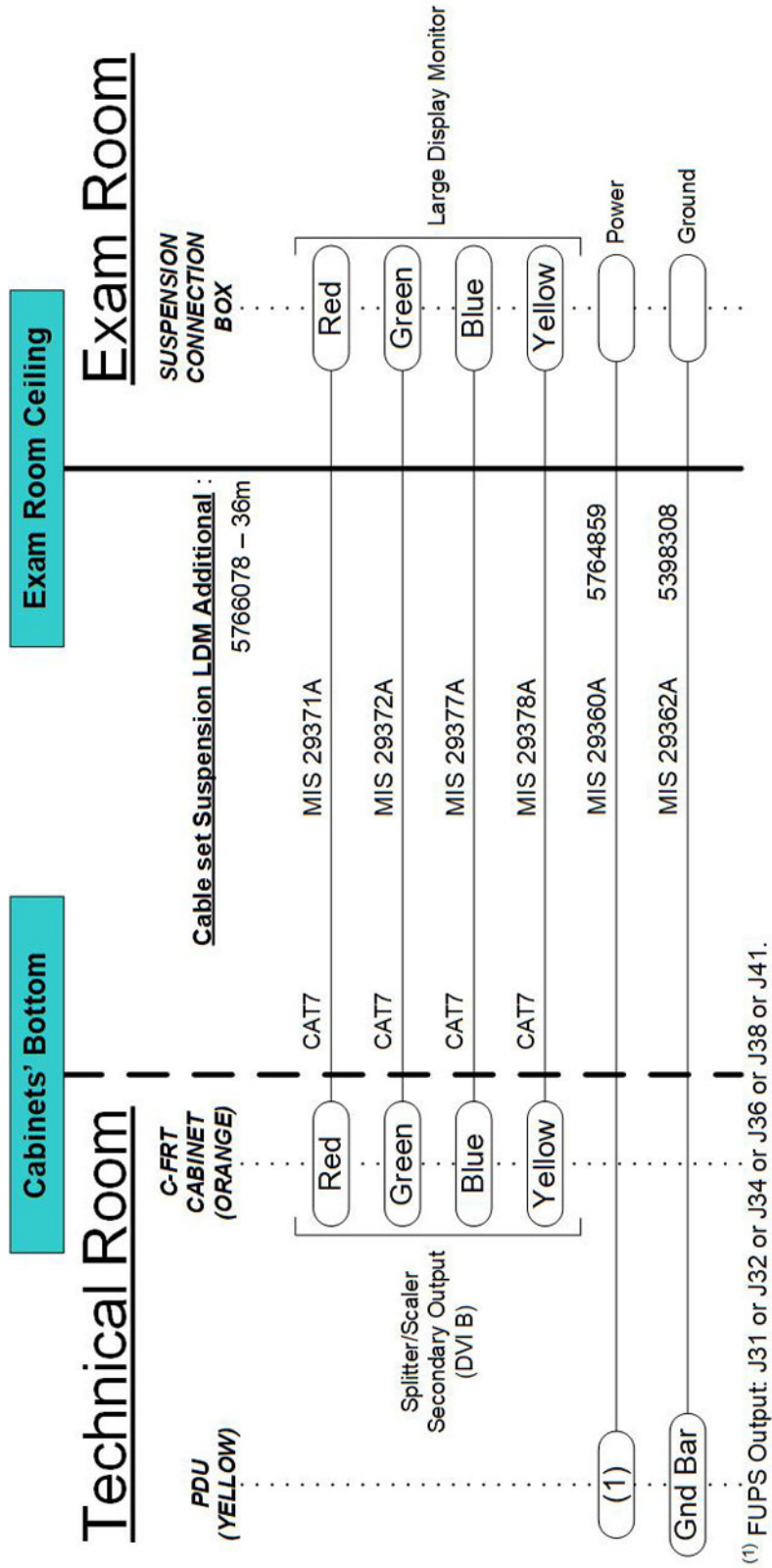
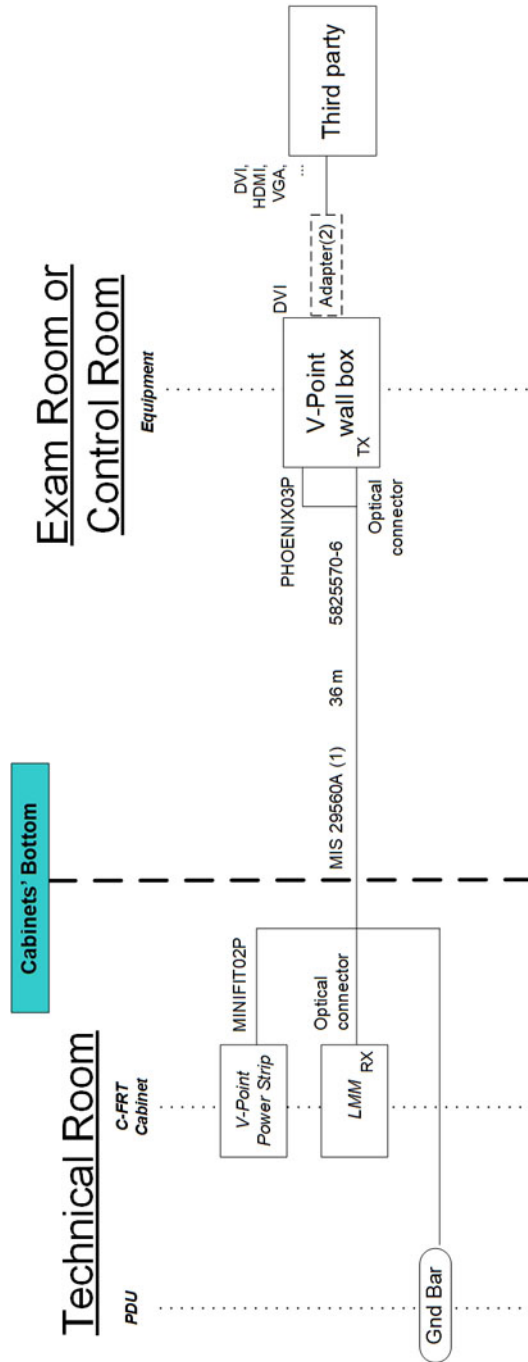


Figure 138 Cable Group - From Technical Room to additional LDM



**Figure 139 Cable Group - V-Point Option**



- (1) Minimum radius of curvature for the Optical Fiber: 30 mm.
- (2) Adapter is under customer responsibility.

### 5.7.1.3 Physical Run - System Core Detail

**Table 39**

MIS number	Cable Assembly	UL Style	Voltage rating (V)	Max Voltage carried (V)	Cable diameter (mm)	Connector type	Bigger Plug size (mm)
<b>Group n°1 (From Technical Room to Exam Room)</b>							
27510A	2261135					WATER HOSE	
27511A	2261135					WATER HOSE	
27512A	5450901					OPTICAL FIBER	
27662A	5191563		30		7	AMP 8 pin RJ45	
27663A	5404121	2789	600		13.8	DB 11 pin	34.4
27664A	5439433						
27665A	5404290	2463	300		9.2	Metrimate 6 pin	29
27666A	2352342					WATER HOSE	
27667A	2352342					WATER HOSE	
27669A	5763117						
27670A	5404120	2789	300			HES 15 pin	
27671A	5404120	2789	30		10.9	Amplimite 100 pin	84.6
27672A	5191220	2789	30		10.9	Amplimite 100 pin	84.6
27673A	5191220	2789	30		10.9	Amplimite 100 pin	84.6
29172A	5483526	2464	300		12.7		
29284A / 29351A	5760919	2587	600				
29283A	5760234						
29402A	5398308						
29403A	5398308						
<b>Ground Cables Group</b>							
29408A	5398308	1019	600		9.1	Pre-stripping, ring terminal (only with Innova <sup>IQ</sup> table (P/N 5142213-001)	12

continued							
MIS number	Cable Assembly	UL Style	Voltage rating (V)	Max Voltage carried (V)	Cable diameter (mm)	Connector type	Bigger Plug size (mm)
29409A	5398308	1019	600		9.1	Pre-stripping, ring terminal (only with Innova <sup>IQ</sup> table (P/N 5142213-001)	12
<b>Group n°2 (From Technical Room to Control Room)</b>							
27493A	5191563						
27494A	5405128	2464	300		6	DB 9 pin	30.9
27505A	5191563						
27676A	5762397						
29010A	5763118						
29011A	5763118						
29012A	5763118						
29024A	5763118		1				
29043A	5763118						
29194A	5763119						
29285A	5760830						
29297A	5760904						
29352A	5760904						
29353A	5760904						
29354A	5760852					I	
29355A	5761553						
<b>Optional Fast Link Cable</b>							
29058A	5760904						
<b>Group n°3 (From Technical Room to Technical Room)</b>							
27677A	5405105	2463	600		8.3	Metrimate 6 pin	29.8
28254A	5760953						
29356A	5760702						
27523A	5405107						
29286A	5760954						

continued							
MIS number	Cable Assembly	UL Style	Voltage rating (V)	Max Voltage carried (V)	Cable diameter (mm)	Connector type	Bigger Plug size (mm)
29287A	5760955						
29288A	5760838						
29289A	5760530						
29290A	5760534						
29291A	5760956						
29292A	5760958						
29298A	5191563					RJ45	
29319A	5191563					RJ45	
29357A	5761376						
<b>Group n°4 (Optional Monitor)</b>							
29293A /B/C/D	5760999	2343					
29295A /B/C/D	5760904						
<b>1 kVA UPS Cable Group</b>							
29317A	5760628						
29318A	5760631						
<b>8 kVA UPS Cable Group</b>							
29315A	5760535						
29316A	5760535						
<b>Cable Set Suspension 4-6 Monitors</b>							
29358A	5764955						
29359A	5764953						
29361A	5398308						
29363A	5760904						
29364A	5760904						
29365A	5760904						
29366A	5760904						

continued							
MIS number	Cable Assembly	UL Style	Voltage rating (V)	Max Voltage carried (V)	Cable diameter (mm)	Connector type	Bigger Plug size (mm)
29367A	5760904						
29368A	5760904						
29379A	5764956						
29380A	5764957						
29381A	5764957						
<b>Cable Set Suspension LDM Mavig Suspension</b>							
29358A	5764955						
29359A	5764953						
29361A	5398308						
29369A	5760904						
29370A	5760904						
29373A	A5E100012 66 EIZO						
29374A	A5E100012 66 EIZO						
29375A	A5E100012 66 EIZO						
29376A	A5E100012 66 EIZO						
29379A	5764956						
29412A	5764953						
<b>Cable Set Suspension LDM Additional</b>							
29360A	5764859						
29362A	5398308						
29371A	A5E100012 66 EIZO						
29372A	A5E100012 66 EIZO						
29377A	A5E100012 66 EIZO						

continued							
MIS number	Cable Assembly	UL Style	Voltage rating (V)	Max Voltage carried (V)	Cable diameter (mm)	Connector type	Bigger Plug size (mm)
29378A	A5E100012 66 EIZO						
<b>Cable Set Suspension LDM 3rd Party Suspension</b>							
29358A	5764955						
29359A	5764953						
29361A	5398308						
29369A	5760904						
29370A	5760904						
29373A	A5E100012 66 EIZO						
29374A	A5E100012 66 EIZO						
29375A	A5E100012 66 EIZO						
29376A	A5E100012 66 EIZO						
29379A	5764956						
29412A	5764953						
29413A	5764953						
29414A	5398308						
29415A	5398308						
29416A	5398308						
<b>V-Point Cables</b>							
29559A	5819156						
29560A	5825570-6				20		

### 5.7.2 MIS (Master Interconnect System)

Innova system interconnect cables are described in MIS (Master Interconnect System) documents. These documents specify all interconnections between components within the system.

Reference: For specific Vascular system interconnect maps and connection details, refer to the following

- *System MIS Map*
- *System MIS Charts*

### **General Guidelines**

Innova System introduces a new system interconnect with a star distribution for all cables from the technical area. The cables are shipped on spools to create cable groups. Cable group 1 for Exam room and cable group 2 for control room. The cable group shall be put in place during the same action. The cables are routed in the same duct.

The HV cables could be pulled separately.

## **5.7.3 Cable Channeling**

### **5.7.3.1 General**

High voltage and power cables must be separated from other cables. Use a separate trough in the duct system, or use a separate conduit. Minimize cable length between the MDP and the PDU to reduce voltage regulation problems and wiring costs.

For information about the cables supplied with your system, please refer to [Physical Runs](#).

### **5.7.3.2 Conduit**

Separate conduits must be used for power and signal wires. These wires must be kept separated from each other.

Using conduit imposes some important considerations when used with this system. Of primary concern, the majority of cables used are pre-terminated. Pre-termination greatly simplifies interconnection but makes cable-pulling difficult because of the added dimensions of the connectors.

Conduit must be large enough to pass the cable and connector through with all other cables already in the conduit. Also, the size of conduit chosen must allow for future growth. There is the possibility of additional cables being added later as the system is developed and options are added.

The use of conduit is recommended for cables running overhead between rooms, especially when a diagonal run provides the shortest cable path

### **5.7.3.3 Electrical Ducts**

It's important that electrical ducts have separate compartments for power and signal wires. These wires must be kept separated from each other for proper system operation.

Electrical ducts have advantages, when used with a single room or two adjacent rooms. Electrical ducts combine cabling in a neat and functional appearance, with accessibility and room for expansion.

#### **NOTE**

Medrad AVANTA and Mac-lab cables exit behind the table in the Exam Room.

#### **NOTE**

For **Fast Link** cable (C-FRT Cabinet - AW station), the static operation bending radius must be at least 4 times the outer cable diameter.

It is the responsibility of the site planner to provide the appropriate solution to the table exit (e.g gas box, Clab II, Tram module, connection interface box).

**NOTE**

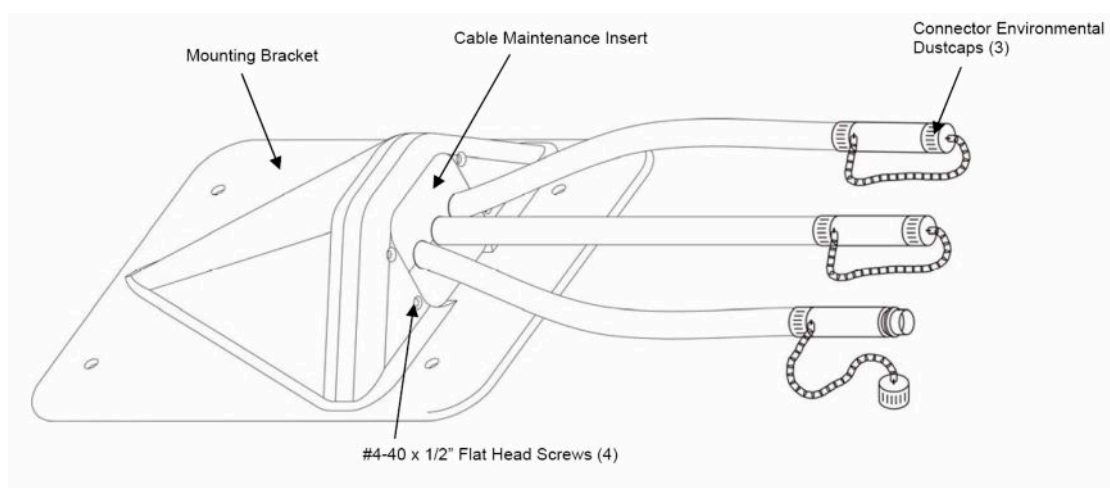
Specific Recommendations for installation with GE ECG Device such as MacLab, CardioLab or ComboLab:

- TRAM RAC in Exam Room with cable 2016134-106 routed back to Control Room where the other modules & PC are installed
- If no GE Maclab cable 2016134-106 installed between the TRAM (Exam Room) and the Control Room, need to route it so that installation/connection of Physio module can be made in Control Room.

**NOTE**

**MEDRAD Avanta Table mount with floor Medrad bracket (this configuration is not authorized with an Innova<sup>IQ</sup> Table):** A 76.2 mm (3 in) and max 25 m (984 in) length conduit between Technical Room and Exam Room shall be prepared below the floor for the three injector cables. It is recommended to use the MEDRAD Avanta floor mounting bracket to cover the duct hole in the Exam Room if there is no gases box.

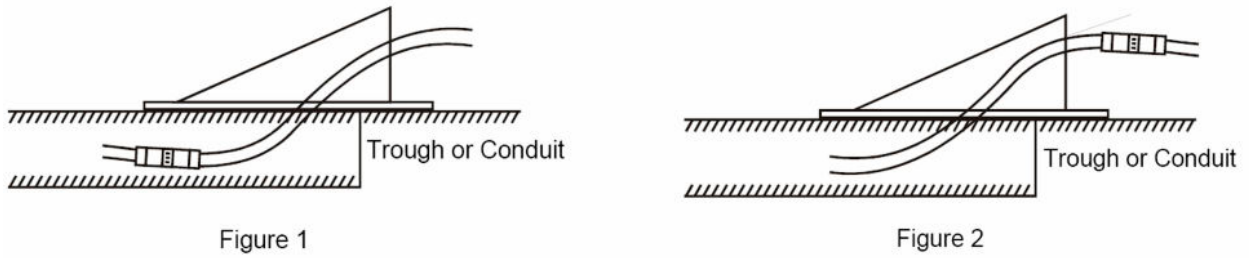
**Figure 140 MEDRAD Avanta mounting bracket**



Floor mount installation can be accomplished one of two ways:

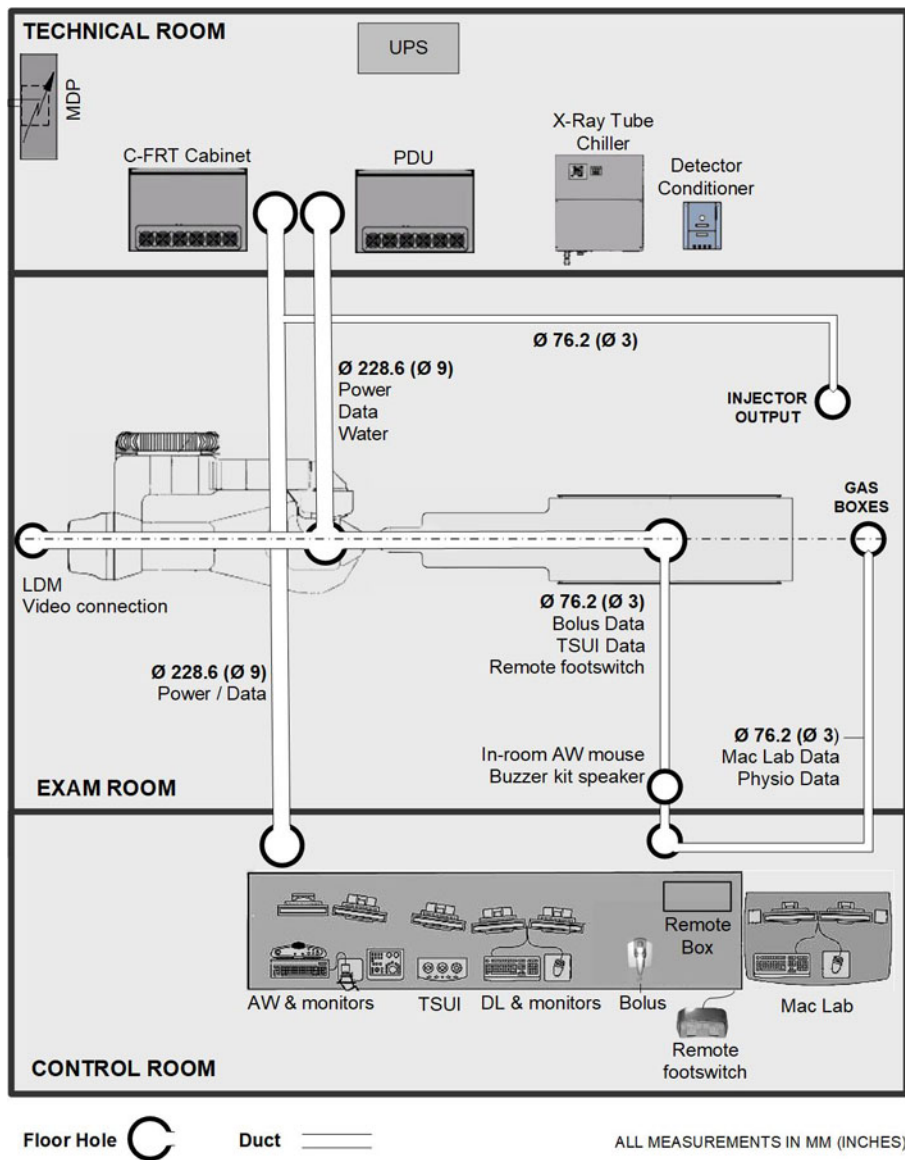
- Connectors mounted in trough under mounting bracket (Figure 1)
- Connectors mounted above mounting bracket (Figure 2)

**Figure 141 MEDRAD Avanta floor mounting methods**



For further MEDRAD Avanta floor mounting, see the Installation guide MEDRAD Avanta Floor Mounting Bracket.

**Figure 142 Cable Channeling Layout**





**NOTICE**

In some countries, it is forbidden to run electrical cables and water pipes in the same conduit. In this case, two separate conduits are required.



**NOTICE**

Raceways or cable trays containing electrical conductors shall not contain any pipe, tube or equal for steam, water, air, gas, drainage or any service other than electrical.

**NOTE**

Only the MEDRAD Mark 7 injector with extension cable and the MEDRAD Avanta injector with extension cable require a separate duct.

**NOTE**

The Physio cable can run in the same conduit as the Bolus cable. In this case, it is required to have a conduit between the table and the physio gases box.

If no conduit available between rear of table and Control Room (no Remote TSUI, no MacLab...), need to define proper cable routing or create new conduit as per PIM requirements.

If there is no physio gases box behind the table in the lay out, find a local solution to hide the hole in the floor and the cable exit.

# Chapter 6 Communication Requirements

## 6.1 Network Requirements

### 6.1.1 General Information

The system is provided with an internal firewall unit mounted inside the system cabinet and that allows connection to the hospital network for pushing the DICOM images or for service remote access (InSite-RSvP). This firewall is compatible with 10/100/1000 (Gigabit Ethernet) networks.

The C-FRT Cabinet provides an Ethernet RJ45 plug, but the customer is responsible for providing the Ethernet cable between the system and the hospital network.

#### NOTE

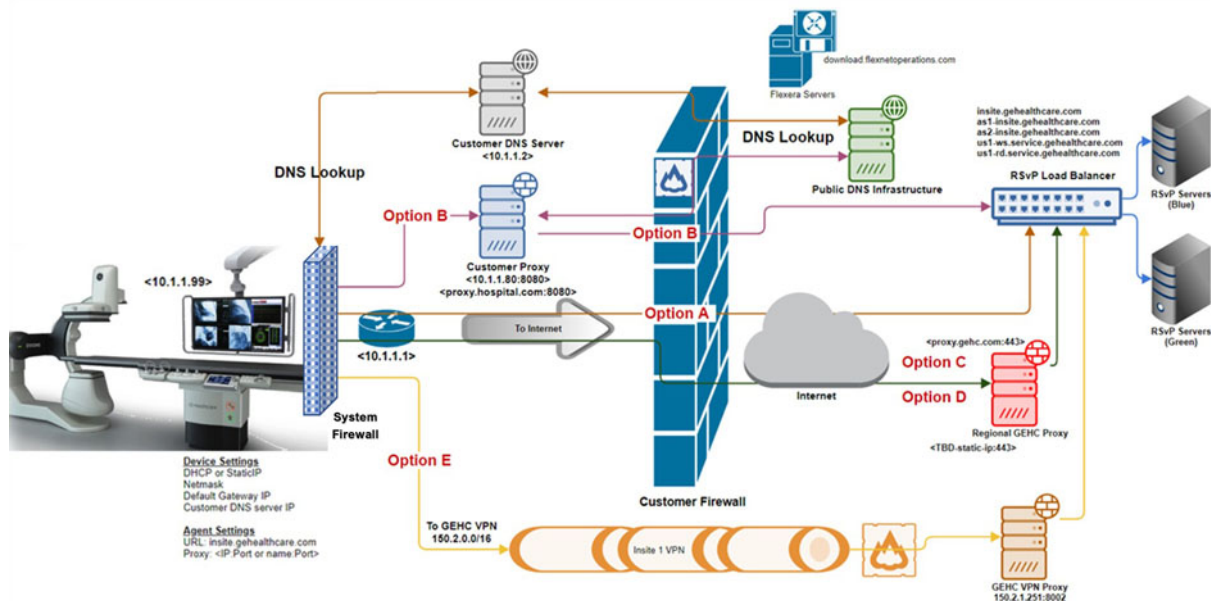
- Connectivity Solutions and pre-installation checklists are available through your local GEHC sales and service representative.
- For InSite-RSvP connections, see information in subsequent sections.

### 6.1.2 InSite-RSvP Connection Requirements

Service Connectivity for new systems will be based on the Insite-RSvP Platform which allows to configure a direct Internet connection to the RSvP Server (routers/VPN tunnel no more mandatory). Communication with the RSvP server will be outbound only and require using Transport Layer Security (TLS) over TCP port 443. This is commonly known as an HTTPS (HTTP-Secure) connection.

There will be several ways to connect the system to the RSvP Enterprise Server. See below the main options that might not be all available or authorized at your site depending on actual network constraints or local regulations.

**Figure 143 Connection to the RSvP Enterprise Server - Example**



**NOTE**

- The system allows for DNS configuration or proxy server-based connection to the Internet (Option A & B).
- Connection thru a GE Proxy will be possible in the future (Option C & D).
- In the case the customer does not accept the above connection protocol or regulatory reasons prevent using these types of configurations, the local/regional connectivity teams can provide help to connect through SSL/TLS proxy IP over the site-to-site VPN (Option E).

To make the system connectivity operational before the system installation is finished, ensure the connectivity solution is defined as early as possible during the pre-installation process and proper information are exchanged between the customer Network Administrators and GEHC Sales and/or Service representatives.

The Support Central links where information from the InSite Connectivity Team or Insite Request Form or support on Insite-RSvP can be found are:

- **Americas:** [http://supportcentral.ge.com/products/sup\\_products.asp?prod\\_id=73661](http://supportcentral.ge.com/products/sup_products.asp?prod_id=73661)
- **Asia:** [http://supportcentral.ge.com/products/sup\\_products.asp?prod\\_id=19181](http://supportcentral.ge.com/products/sup_products.asp?prod_id=19181)
- **Europe:** [http://supportcentral.ge.com/products/sup\\_products.asp?prod\\_id=24026](http://supportcentral.ge.com/products/sup_products.asp?prod_id=24026)
- **RSvP Platform:** [http://supportcentral.ge.com/products/sup\\_products.asp?prod\\_id=280498](http://supportcentral.ge.com/products/sup_products.asp?prod_id=280498)

**6.1.3 Connection Configuration Parameters**

Firstly, the IP addresses for DL and AW PCs have to be requested to the Customer Network Administrators at the time of pre-install to not delay the installation along with:

- A IP address of the hospital Gateway.
- A Subnet mask.
- If additional routers and/or static routes are used by the hospital, those must also be provided.

Regarding the Remote Service connection, the following information will be required from the site depending on their preferred solution:

- the Final system ID for the site (final registration in the CRM/FFA)
- a Domain Name System (DNS) server IP addresses
- or a Proxy server IP or Domain Name and Port
- if a customer wants to only whitelist the specific URLs, the following are the required URLs for RSvP connectivity:
  - <https://insite.gehealthcare.com>
  - <https://as1-insite.gehealthcare.com>
  - <https://as2-insite.gehealthcare.com>
  - <https://gehealthcare-ns.flexnetoperations.com> (for future use only)
  - <https://download.flexnetoperations.com> (for future use only).

#### NOTE

- The System PC (DL) and System Firewall module configurations may differ depending on the final connectivity solution chosen.
- If needed, refer to *InSite® RSvP Agent User OR Technical Reference Manual* for details regarding requesting an RSvP connection setup for the customer.

Refer to Section [6.3 Privacy and Security Configuration on page 204](#) to access the complete list of parameters related to the Privacy and Security configurations that may apply to your site and impact network configurations.

#### Important Note:

- To configure and verify the RSvP connection, the following accesses will be required:
  - CRM: Contact the regional field support teams to get access to the correct CRM in the region.
  - FFA: Sign in to [http://supportcentral.ge.com/products/sup\\_products.asp?prod\\_id=308906](http://supportcentral.ge.com/products/sup_products.asp?prod_id=308906) and apply for FFA access after completing the required training.
  - RSvP: Sign in to [http://supportcentral.ge.com/products/sup\\_products.asp?prod\\_id=280498](http://supportcentral.ge.com/products/sup_products.asp?prod_id=280498) and apply for RSvP access based on region and modality needed after completing the required training.
- The Training(s) required for access are listed on the linked support central sites.

## 6.2 DICOM Requirements

The IGS products are DICOM compliant, allowing them to be connected in a network with other DICOM compliant devices for the exchange of images and data.

In some cases, detailed evaluations of the DICOM implementations of devices are needed to ensure interoperability. For this purpose, the DICOM Conformance Statement can be accessed at <https://www.gehealthcare.com/products/interoperability/dicom/xray-mammography-dicom-conformance-statements>, and the IHE Integration Statement can be accessed at <https://www.gehealthcare.com/products/interoperability/ihe/xray-mammography-acquisition-systems-ihe-integration-statements>.

## 6.3 Privacy and Security Configuration

The Privacy and Security features available with the System require to be configured according to the security policy requested by the hospital.

To ensure the installation is successful and is not delayed because of missing information, it is required to gather all needed information as part of the pre-install process.

The typical parameters are the one listed below. The complete list is provided in Tab "Security Configuration" of the document *IGS System Installation Prerequisites - DOC2024755*. See also Important Notice below.

- **Machine Account**
- **User Authentication**
- **Authorization**
- **Audit Trail**
- **Malware protection**
- **Network Security**
- **Data Transmission and Protection**
- **Other Requirements**



### NOTICE

- Always refer to the detailed Checklist provided in the document *IGS System Installation Prerequisites - DOC2024755* available from MyWorkshop. Always use the last revision which will contain all mandatory updates.
- For details on the new Privacy and Security features available with this machine, refer to the document *Privacy and Security Manual - P/N 5831110-299* available from MyWorkshop.
- Support on Privacy and Security can also be found here (USCAN only): [http://supportcentral.ge.com/products/sup\\_products.asp?prod\\_id=259836](http://supportcentral.ge.com/products/sup_products.asp?prod_id=259836).



General Electric Company  
283, rue de la Minière  
Buc 78530 FRANCE



Innova™ IGS 5