

DISCLAIMER

GENERAL SPECIFICATIONS

- GE is not responsible for the installation of developers and associated equipment, lighting, cassette trays and protective screens or derivatives not mentioned in the order.
- The final study contains recommendations for the location of GE equipment and associated devices, electrical wiring and room arrangements. When preparing the study, every effort has been made to consider every aspect of the actual equipment expected to be installed.
- The layout of the equipment offered by GE, the dimensions given for the premises, the details provided for the pre-installation work and electrical power supply are given according to the information noted during on-site study and the wishes expressed by the customer.
- The room dimensions used to create the equipment layout may originate from a previous layout and may not be accurate as they may not have been verified on site. GE cannot take any responsibility for errors due to lack of information.
- Dimensions apply to finished surfaces of the room.
- Actual configuration may differ from options presented in some typical views or tables.
- If this set of final drawings has been approved by the customer, any subsequent modification of the site must be subject to further investigation by GE about the feasibility of installing the equipment. Any reservations must be noted.
- The equipment layout indicates the placement and interconnection of the indicated equipment components. There may be local requirements that could impact the placement of these components. It remains the customer's responsibility to ensure that the site and final equipment placement complies with all applicable local requirements.
- All work required to install GE equipment must be carried out in compliance with the building regulations and the safety standards of legal force in the country concerned.
- These drawings are not to be used for actual construction purposes. The company cannot take responsibility for any damage resulting therefrom.

CUSTOMER RESPONSIBILITIES

- It is the responsibility of the customer to prepare the site in accordance with the specifications stated in the final study. A detailed site readiness checklist is provided by GE. It is the responsibility of the customer to ensure all requirements are fulfilled and that the site conforms to all specifications defined in the checklist and final study. The GE Project Manager of Installation (PMI) will work in cooperation with the customer to follow up and ensure that actions in the checklist are complete, and if necessary, will aid in the rescheduling of the delivery and installation date.
- Prior to installation, a structural engineer of record must ensure that the floor and ceiling is designed in such a way that the loads of the installed system can be securely borne and transferred. The layout of additional structural elements, dimensioning and the selection of appropriate installation methods are the sole responsibility of the structural engineer. Execution of load bearing structures supporting equipment on the ceiling, floor or walls are the customer's responsibility.

RADIO-PROTECTION

- Suitable radiological protection must be determined by a qualified radiological physicist in conformation with local regulations. GE does not take responsibility for the specification or provision of radio-protection.

THE UNDERSIGNED, HEREBY CERTIFIES THAT I HAVE READ AND APPROVED THE PLANS IN THIS DOCUMENT.		
DATE	NAME	SIGNATURE

CUSTOMER SITE READINESS REQUIREMENTS

REQUIRED MANUALS FOR SYSTEM PRE-INSTALLATION	
Description	Document Number*
Product specific Pre-installation Manual	Refer to cover page
*documents can be accessed in multiple languages at https://www.gehealthcare.com/support/manuals	

- A mandatory component of this drawing set is the GE HealthCare Pre-installation manual. Failure to reference the Pre-installation manual will result in incomplete documentation required for site design and preparation.
- The items on the GE HealthCare Site Readiness Checklist **DOC2949061** and Worksheet **DOC2949068** are **REQUIRED** to facilitate equipment delivery to the site. Equipment will not be delivered if these requirements are not satisfied.
 - Any deviation from these drawings must be communicated in writing to and reviewed by your local GE HealthCare installation project manager prior to making changes.
 - Make arrangements for any rigging, special handling, or facility modifications that must be made to deliver the equipment to the installation site. If desired, your local GE HealthCare installation project manager can supply a reference list of rigging contractors.
 - New construction requires the following;
 1. Secure area for equipment,
 2. Power for drills and other test equipment,
 3. Restrooms.
 - Provide for refuse removal and disposal (e.g. crates, cartons, packing)
 - It is required to minimize vibrations within the scan room. It is the customer's responsibility to contract a vibration consultant/engineer to implement site design modifications to meet the GE vibration specification. Refer to the system Pre-installation manual for vibration specifications.

RADIOACTIVE ISOTOPES

USING RADIOACTIVE ISOTOPES

Since the Discovery NM 630 involves the use of radioactive isotopes, compliance with Nuclear Regulatory Commission regulations, or similar regulatory requirements (depending on the country), must be adhered to and all permissions obtained well in advance. It is recommended that regulatory compliance is arranged early in the site planning process.

It is essential that all preparations are completed so that required source materials can be obtained prior to installation, including calibration sources. Take into consideration that these sources may have fairly long delivery lead times, yet may also have a short half life, so that it may not be advisable to store them over long periods of time.

RADIOACTIVE ISOTOPES FOR SYSTEM CALIBRATION

DESCRIPTION	
Basic calibration	Site has license for Tc ^{99m}
	Tc ^{99m} will be available during installation
Isotopes to be used at site are available for installation. Note: Specify age and strength	Co ⁵⁷ (Rectangular Flood Source)
	Tl ²⁰¹
	I ¹³¹
	I ¹²³
	In ¹¹¹
	Ga ⁶⁷
	Xe ¹³³ (inhalation gas)

ENVIRONMENT

ALTITUDE

Operating altitude: from -150 m [-492 ft] to 4100 m [13451 ft].

MAGNETIC FIELD SPECIFICATIONS

In order to avoid interference on the system, the static field limits from the surrounding environment must be less than 1 Gauss in both the scan and the operator rooms.

VIBRATION SPECIFICATIONS

The system components are sensitive to vibration in the frequency range of 0.5 to 20 Hz, depending on the amplitude of the vibration. It is the customer's responsibility to contract a vibration consultant or qualified engineer to verify that these specifications are met and implement an appropriate solution.

To minimize vibrations, the system must be installed on a solid floor, as far as possible from vibration sources (parking lots, roadways, heliports, elevators, hospital power plants... etc).

Please refer to the PIM for detailed information.

ACOUSTIC SPECIFICATIONS

It is less than 70 dBA measured at a distance of one meter from the nearest gantry surface, in any direction.

It is recommended that the wall and ceiling surface is of a sound dampening material so that the noise is not reverberated and amplified.

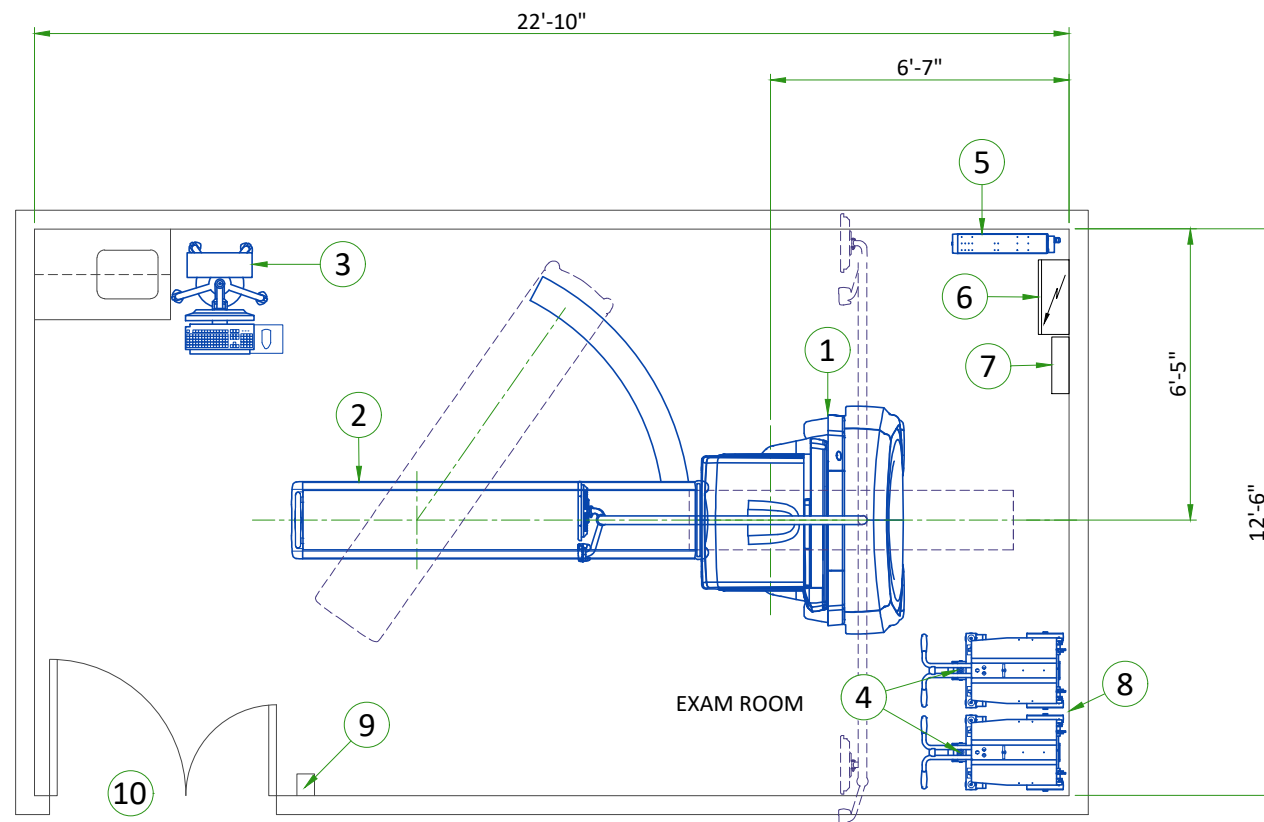

LEGEND

A	GE SUPPLIED	D	AVAILABLE FROM GE			
B	GE SUPPLIED/CONTRACTOR INSTALLED	E	EQUIPMENT EXISTING IN ROOM			
C	CUSTOMER/CONTRACTOR SUPPLIED AND INSTALLED	*	ITEM TO BE REINSTALLED FROM ANOTHER SITE			
BY	ITEM	DESCRIPTION	MAX HEAT OUTPUT (BTU/h)	WEIGHT (lbs)	MAX HEAT OUTPUT (W)	WEIGHT (kg)
A	1	GANTRY (WITHOUT COLLIMATORS)	4504	4251	1320	1928
A	2	PATIENT TABLE	682	794	200	360
A	3	AQUISITION WORKSTATION ON MOBILE CART	256	44	75	20
A	4	COLLIMATOR CART	-	728	-	330
A	5	6 kVA UPS	1501	106	440	48
D	6	MAIN DISCONNECT PANEL	-	-	-	-
C	7	UPS DISCONNECT	-	-	-	-
C	8	OPTIONAL WALL PROTECTION FROM COLLIMATOR CART				
C	9	SHELF FOR EMO				
C	10	MINIMUM OPENING FOR EQUIPMENT DELIVERY IS 1422 mm x 2210 mm [56 in x 87 in]* CONTINGENT ON A 2438 mm [96 in] CORRIDOR WIDTH				

* DOOR WIDTH CAN BE REDUCED TO 1000 mm [39.4 in] WITH THE DETECTOR DISMOUNT DELIVERY OPTION

EXAM ROOM HEIGHT

FINISHED FLOOR TO SLAB HEIGHT	TBD
FALSE CEILING HEIGHT	8'-9"

For Accessory Sales: (866) 281-7545 Options 1, 2, 1, 2 or mail to: gehaccessorysales@ge.com

GANTRY AND PATIENT TABLE

SIDE VIEW

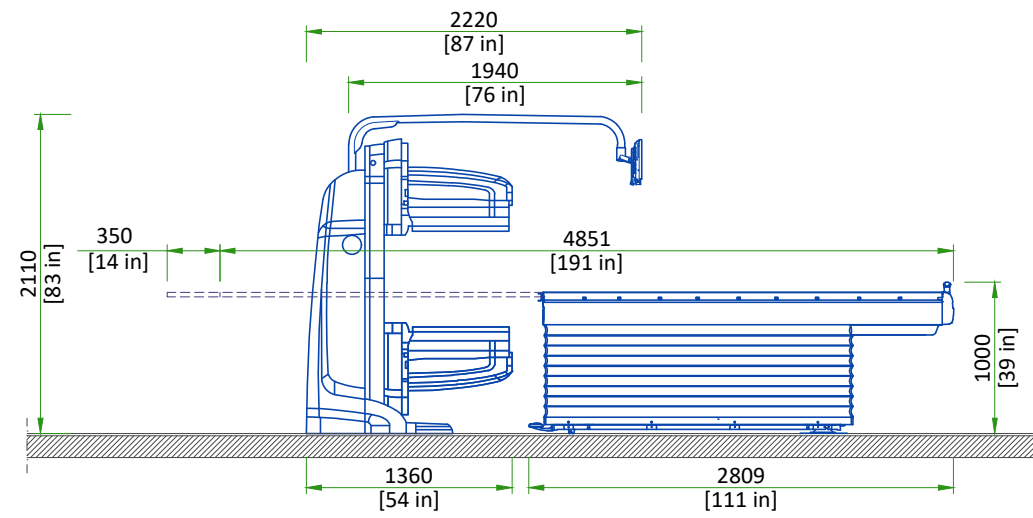

NOT TO SCALE

COLLIMATOR CARTS

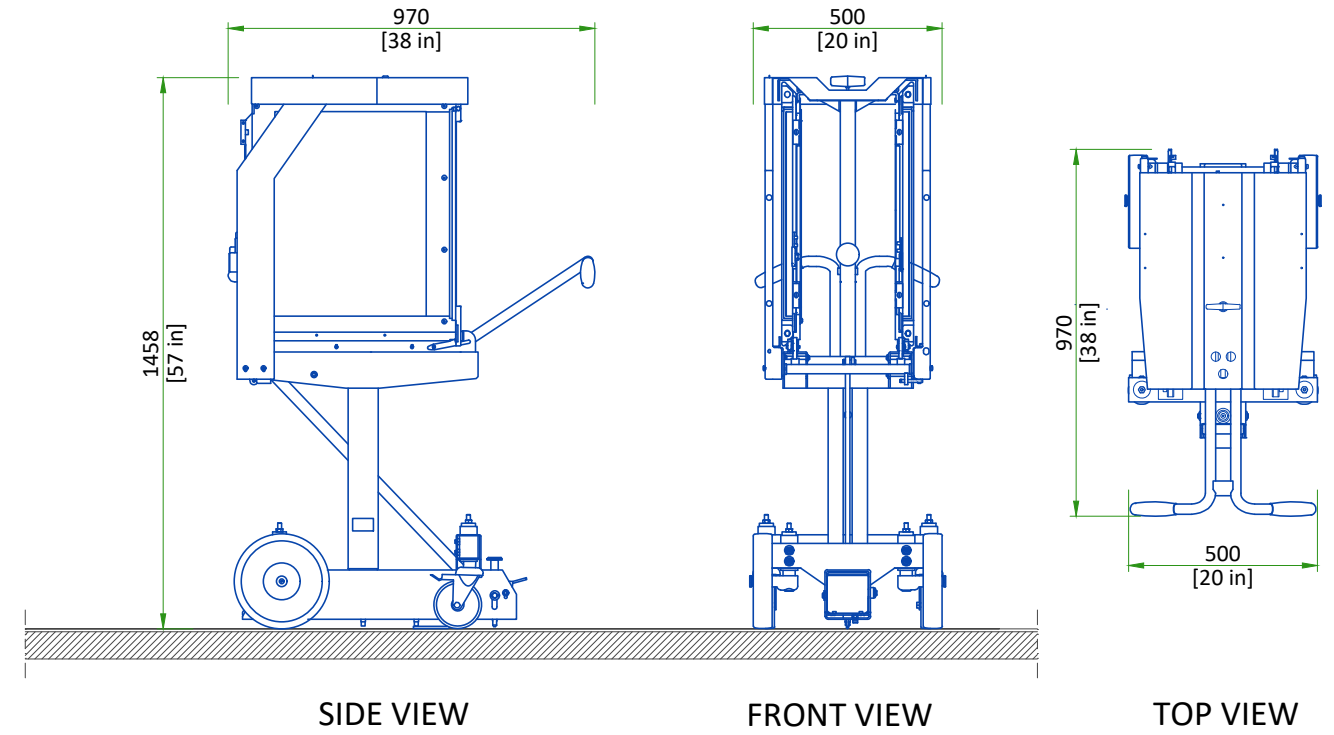

SCALE 1:20

PATIENT TABLE

TOP VIEW

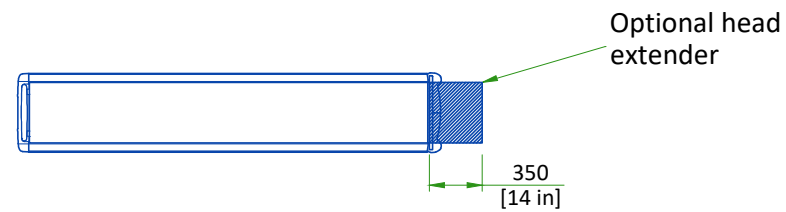

SIDE VIEW

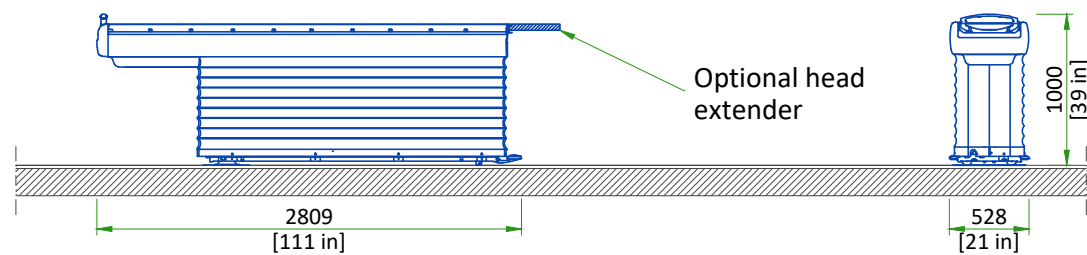

FRONT VIEW

NOT TO SCALE

UNINTERRUPTIBLE POWER SUPPLY (UPS)

TOP VIEW

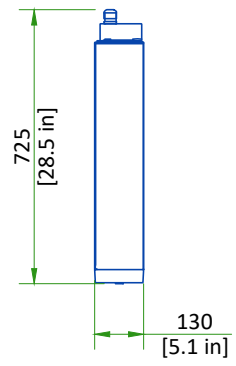

FRONT VIEW

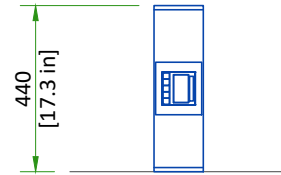

SIDE VIEW

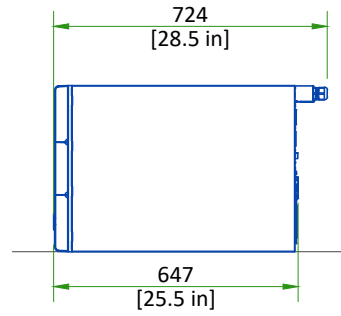

SCALE 1:20

ACQUISITION STATION ON CART

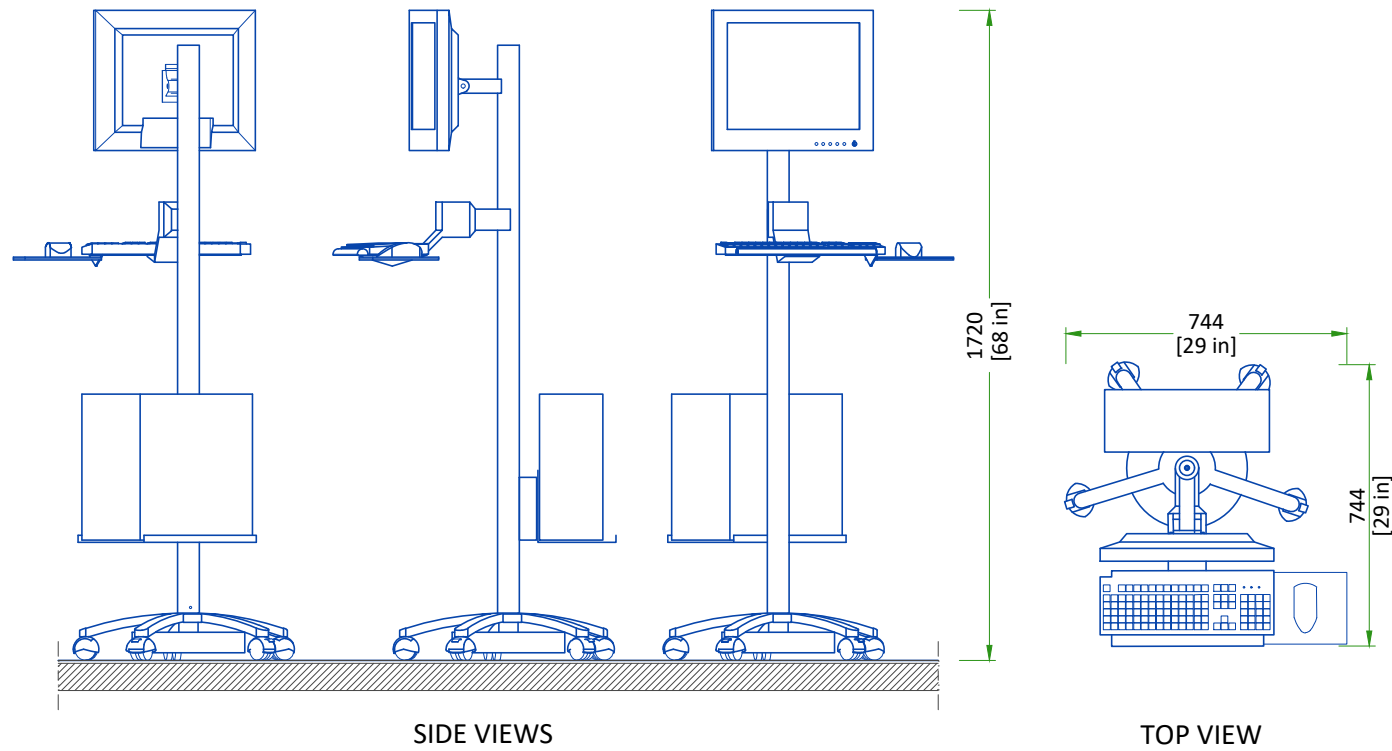

STRUCTURAL NOTES

- All units that are wall mounted or wall supported are to be provided with supports where necessary. Wall supports are to be supplied and installed by the customer or his contractors. See plan and detail sheets for suggested locations and mounting hole locations.
- Floor slabs on which equipment is to be installed must be flat and level to specifications.
- Dimensions are to finished surfaces of room.
- For seismic regions ensure supports span three members.
- Customers contractor must provide all penetrations in post tension floors.
- Customers contractor must provide and install any non-standard anchoring. Documents for standard anchoring methods are included with GE equipment drawings for geographic areas that require such documentation.
- Customers contractor must provide and install hardware for "through the floor" anchoring and/or any bracing under access floors. This contractor must also provide floor drilling that cannot be completed because of an obstruction encountered while drilling by the GE installer such as rebar etc.
- It is the customer's responsibility to perform any floor or wall penetrations that may be required. The customer is also responsible for ensuring that no subsurface utilities (e.g., electrical or any other form of wiring, conduits, piping, duct work or structural supports (i.e. post tension cables or rebar)) will interfere or come in contact with subsurface penetration operations (e.g. drilling and installation of anchors/screws) performed during the installation process. To ensure worker safety, GE installers will perform surface penetration operations only after the customer's validation and completion of the "GE surface penetration permit"

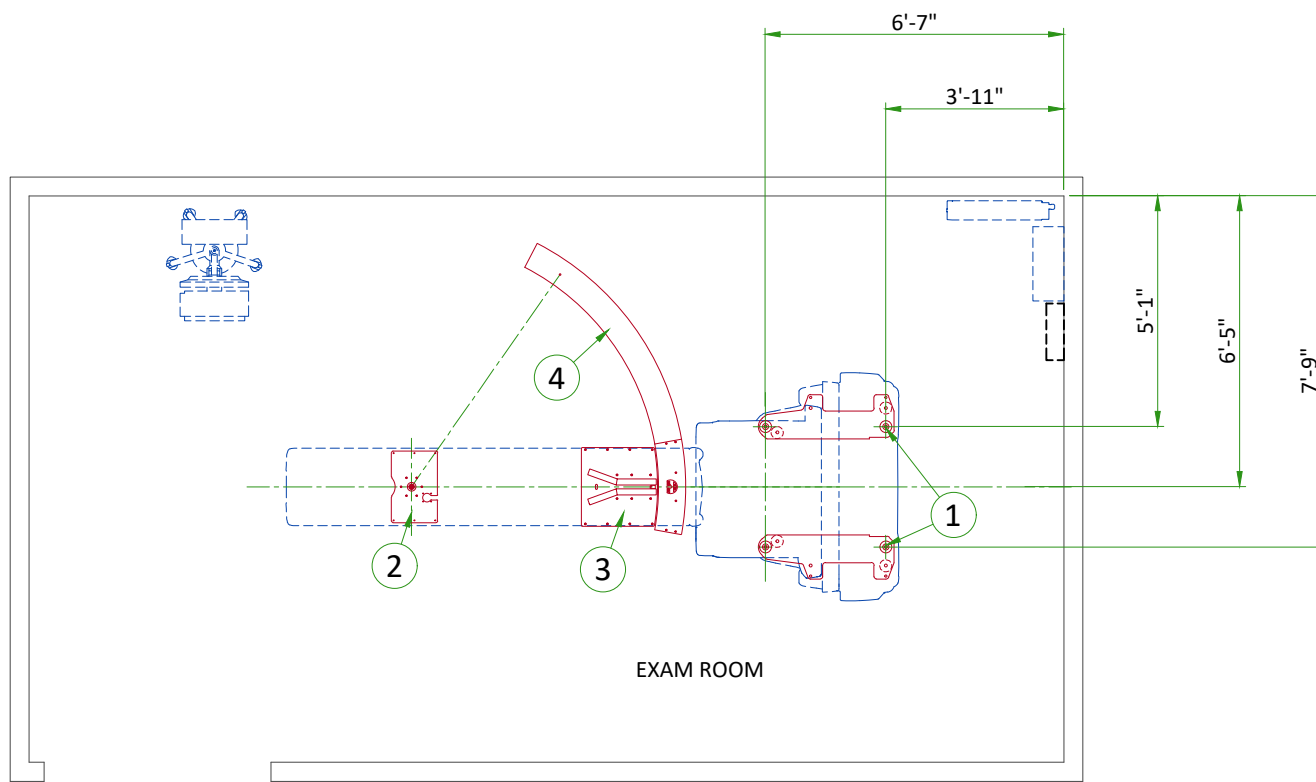

ITEM	DESCRIPTION
(GE SUPPLIED / CONTRACTOR INSTALLED)	
1	Gantry baseplate
2	Table Anchor plate
3	Collimator exchange plate
4	Swing plate

ANCHORING TO THE FLOOR

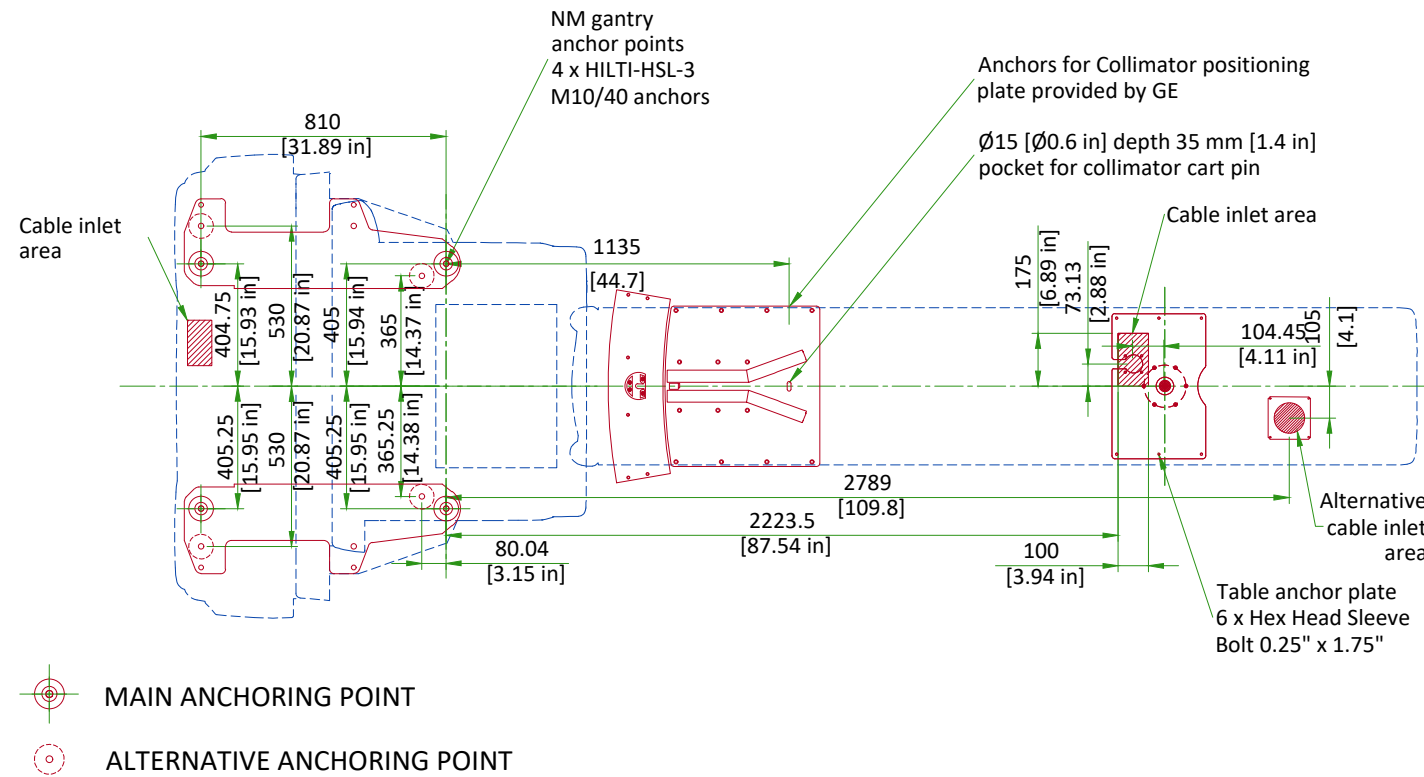

SCALE 1:25

FLOOR SPECIFICATIONS

GANTRY ANCHORING

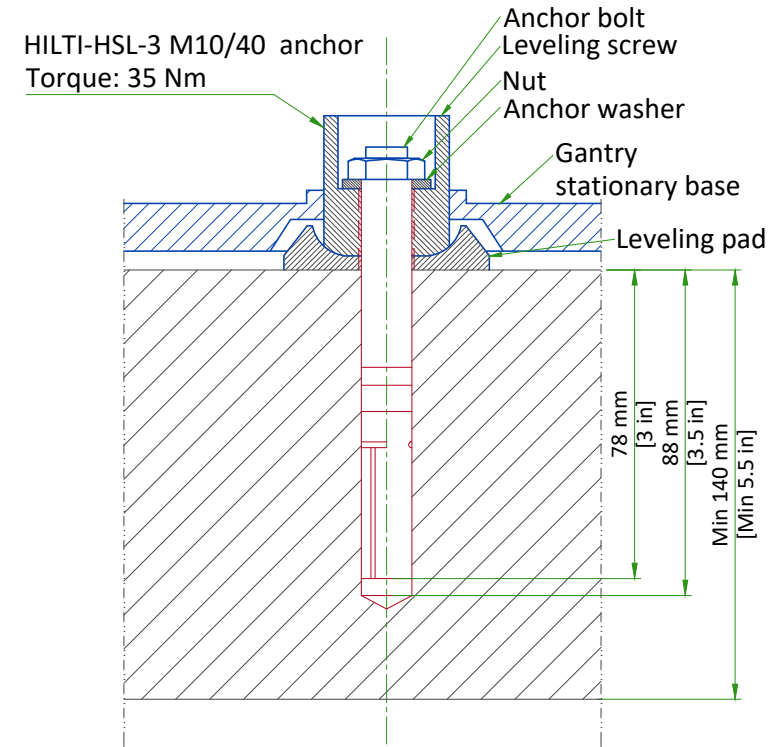

NOT TO SCALE

- Floor leveling area: 512 cm [201.6 in] x 374 cm [147.2 in] (covering the entire planned area of table and gantry surface).
- Slope less than 13 mm [0.5 in] over 4300 mm [160 in], if slope is between 13 mm [0.5 in] and 30 mm [1.18 in] refer to PIM for additional requirements.
- Flatness: the surface must be smooth, with deviations of no more than 5 mm [0.195 in] between depressions and high spots in any 1500 mm [59 in] throughout the room or system installation area.
- Floor surface: a single poured surface.
- Floor strength: in order to enable mounting of the system floor anchors, concrete floors must have a minimum cube strength of $f'c=4350$ psi. (30 MPa) at 28 days (curing time) for 25/30 concrete
- Floor thickness: the system's floor anchors are designed for use only on concrete floors that meet the minimal 140 mm [5.5 in] concrete floor requirements
- The selected anchoring method must have a pulling tensile force of 19.7 kN on each of the anchors bolting the NM gantry to the floor.

LOADING DISTRIBUTION TO THE FLOOR

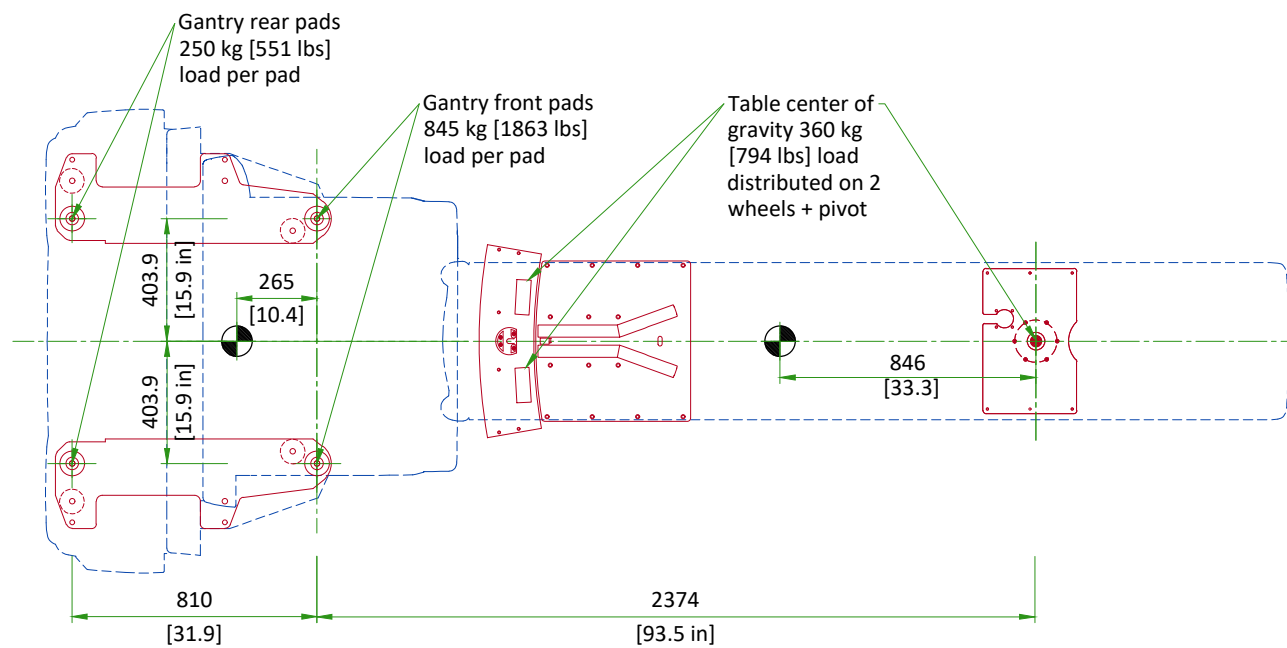

Gantry weight: 2190 kg [4828 lbs]
 (with HEGP collimators mounted)
 Table weight: 360 kg [794 lbs]

SCALE 1:25

TEMPERATURE AND HUMIDITY SPECIFICATIONS

IN-USE CONDITIONS

	EXAM /CONTROL ROOM		
	Min	Recommended	Max
Temperature	18 °C [64 °F]	22 °C [72 °F]	26 °C [79 °F]
Temperature gradient	$\leq 3 \text{ }^\circ\text{C/h}$ [$\leq 5 \text{ }^\circ\text{F/h}$]		
RH (1) non condensing	30% to 60%		
Humidity gradient	$\leq 5\%/h$		

STORAGE CONDITIONS

Temperature	+4°C [+40°F] to +27°C [+80°F]
Relative humidity (1)	20% to 60%
Humidity gradient	$\leq 5\%/h$
Air pressure	700 hPa to 1060 hPa
Storage longer than 12 months is not recommended.	

(1) Relative humidity

AIR RENEWAL

According to local standards.

NOTE

In case of using air conditioning systems that have a risk of water leakage it is recommended not to install it above electric equipment or to take measures to protect the equipment from dropping water.

DELIVERY

THE CUSTOMER/CONTRACTOR SHOULD:

- Provide an area adjacent to the installation site for delivery and unloading of the GEHC equipment.
- Ensure that the dimensions of all doors, corridors, ceiling heights are sufficient to accommodate the movement of GEHC equipment from the delivery area into the definitive installation room.
- Ensure that access routes for equipment will accommodate the weights of the equipment and any transportation, lifting and rigging equipment.
- Ensure that all necessary arrangements for stopping and unloading on public or private property not belonging to the customer have been made.

DIMENSIONS OF DELIVERY WITH DOLLY TRANSPORT EQUIPMENT

EQUIPMENT	DIMENSIONS		WEIGHT
NM GANTRY WITH DETECTORS MOUNTED	LENGTH	1327 mm [52.2 in]	2238 kg [4934 lb]
	WIDTH	2213 mm [87.1 in]	
	HEIGHT	2000 mm [78.75 in]	
NM GANTRY WITHOUT THE DETECTORS	LENGTH	952 mm [37.5 in]	1690 kg [3726 lb]
	WIDTH	2213 mm [87.1 in]	
	HEIGHT	1950 mm [76.7 in]	
TABLE	LENGTH	2809 mm [110.6 in]	360 kg [794 lb]
	WIDTH	900 mm [35.4 in]	
	HEIGHT	1400 mm [55 in]	

HEAT DISSIPATION

ROOM	DESCRIPTION	HEAT DISSIPATION (kW)	HEAT DISSIPATION (BTU/hr)
		MAX	MAX
Exam Room	Gantry	1.320	4500
	Patient table	0.200	682
	TOTAL	1.520	5182
Exam/Control Room	NM acquisition station	0.075	256
	Xeleris Workstation	0.075	256
	6 kVA UPS	0.440	1500
	TOTAL	0.590	2012

CONNECTIVITY REQUIREMENTS

Your new GE Healthcare imaging modality will require local and remote connectivity to enable our full range of digital support:

- Local connectivity - This allows your system to connect to local devices such as PACS and modality worklist. We will require network information to configure the system(s), and a live ethernet port(s) prior to the delivery of the system(s).
- Remote connectivity - Your GE Healthcare service warranty includes InSite™ (applicable to InSite capable products), a powerful broadband-based service which enables digital tools that can help guard your hospital against equipment downtime and revenue loss by quickly connecting you to a GE Healthcare expert.

Depending on product family and software version, imaging systems can be connected in one of the following methods:

1. TLS over TCP Port 443 (Preferred method for new products) via:
 - a. DNS resolution
 - b. Customer-provided Proxy or
 - c. GE Proxy (Available in some regions)
2. Site-to-Site IPsec VPN tunnel

Please provide the GE project manager with the contact information for the resource that can provide information required to set up these connections. GEHC will send out communication to these contacts, which will include the project's Connectivity requirements, and a Connectivity form. This form will need to be completed and returned to GEHC prior to delivery of the system to ensure the system is tested and connectivity is enabled prior to the completion of the installation.

ELECTRICAL NOTES

1. Aluminum or solid wires are not allowed.
2. Wire sizes given are for use of equipment. Larger sizes may be required by local codes.
3. It is recommended that all wires be color coded, as required in accordance with national and local electrical codes.
4. Conduit sizes shall be verified by the architect, electrical engineer or contractor, in accordance with local or national codes.
5. Convenience outlets are not illustrated. Their number and location are to be specified by others. Locate at least one convenience outlet close to the system control, the power distribution unit and one on each wall of the procedure room. Use hospital approved outlet or equivalent.
6. General room illumination is not illustrated. Caution should be taken to avoid excessive heat from overhead spotlights. Damage can occur to ceiling mounting components and wiring if high wattage bulbs are used. Recommend low wattage bulbs no higher than 75 watts and use dimmer controls (except MR). Do not mount lights directly above areas where ceiling mounted accessories will be parked.
7. Routing of cable ductwork, conduits, etc., must run direct as possible otherwise may result in the need for greater than standard cable lengths (refer to the interconnection diagram for maximum usable lengths point to point).
8. Conduit turns to have large, sweeping bends with minimum radius in accordance with national and local electrical codes.
9. In some cases GEHC will specify ground wires to be sized larger than code. In these situations, the GEHC specification must be followed.
10. A special grounding system is required in all procedure rooms by some national and local codes. It is recommended in areas where patients might be examined or treated under present, future, or emergency conditions. Consult the governing electrical code and confer with appropriate customer administrative personnel to determine the areas requiring this type of grounding system.
11. The maximum point to point distances illustrated on this drawing must not be exceeded.
12. Physical connection of primary power to GEHC equipment is to be made by customers electrical contractor with the supervision of a GEHC representative. The GEHC representative would be required to identify the physical connection location, and insure proper handling of GEHC equipment.
13. GEHC conducts power audits to verify quality of power being delivered to the system. The customer's electrical contractor is required to be available to support this activity.
14. Every installation is unique. The electrical contractor will be required to support the installation of the GEHC equipment by providing knockouts, grommeted openings, bushings, etc. as required. All power connections to be performed by the electrician.

- All junction boxes, conduit, duct, duct dividers, switches, circuit breakers, cable tray, etc., are to be supplied and installed by customers electrical contractor. All junction boxes shall be provided with covers.
- Conduit and duct runs shall have gradual sweep radius bends.
- Conduits and duct above ceiling or below finished floor must be installed as near to ceiling or floor as possible to reduce run length.
- Ceiling mounted junction boxes illustrated on this plan must be installed flush with finished ceiling.
- All ductwork must meet the following requirements:
 1. Ductwork shall be metal with dividers and have removable, accessible covers.
 2. Ductwork shall be certified/rated for electrical power purposes.
 3. Ductwork shall be electrically and mechanically bonded together in an approved manner.
 4. PVC as a substitute must be used in accordance with all local and national codes.
- All openings in raceway and access flooring are to be cut out and finished off with grommet material by the customers contractor.
- Electrical contractor to provide measured pull strings in all conduit and raceway runs.
- Provide 10 foot pigtails at all junction points.
- Grounding is critical to equipment function and patient safety. Site must conform to wiring specifications shown on this plan.

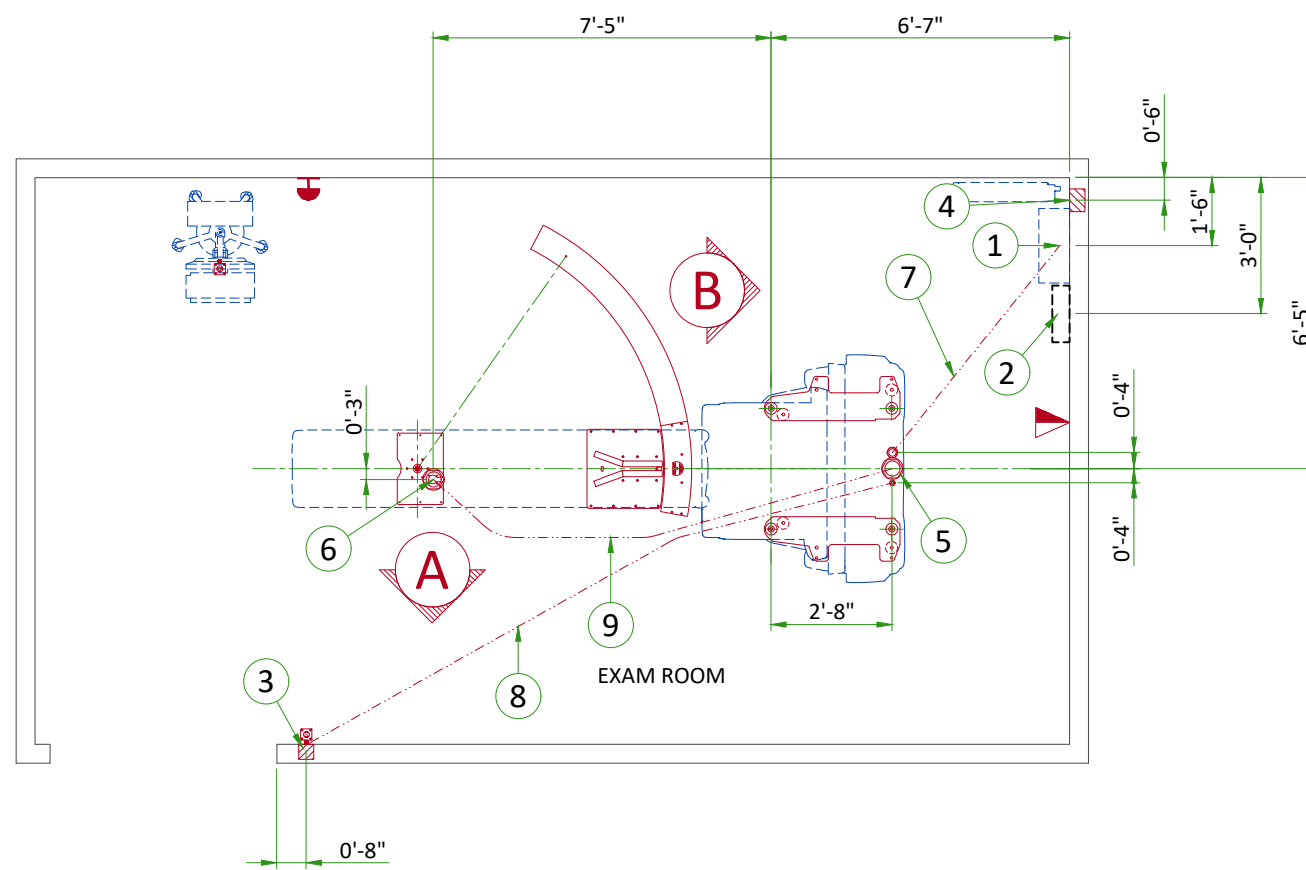

ITEM	Electrical Layout Item List
1	30A, 208V Main Disconnect Panel (MDP) (gantry hardwired)
2	30A, 208V UPS Disconnect Panel (A2)
3	4" x 4" x 4" [100 x 100 x 100] box (EMO)
4	6" x 6" x 4" [150 x 150 x 100] box (UPS)
5	Suitable bushing & locknuts (Gantry)
6	Conduit must be cut flush with finished floor (table)
7	2" [51] conduit below floor
8	3/4" [20] conduit below floor
9	4" [102] conduit below floor

ITEM	QTY	Electrical Outlet Legend
Customer/contractor supplied and installed items unless otherwise specified. Height above floor determined by local codes unless otherwise specified.		
▲		Network outlet
⚡		Remote emergency power off (EPO), (recommended height 1.2m [48"] above floor)

Additional Conduit Runs (Contractor Supplied and Installed)				
From (Bubble # / Item)	To (Bubble # / Item)	Qty	Size	
			In.	mm
Single Phase Power	2 UPS disconnect panel	1	As req'd	As req'd
4 UPS	1 Main disconnect panel	1	As req'd	As req'd
1 Main disconnect panel	Remote EPO	1	1/2	13

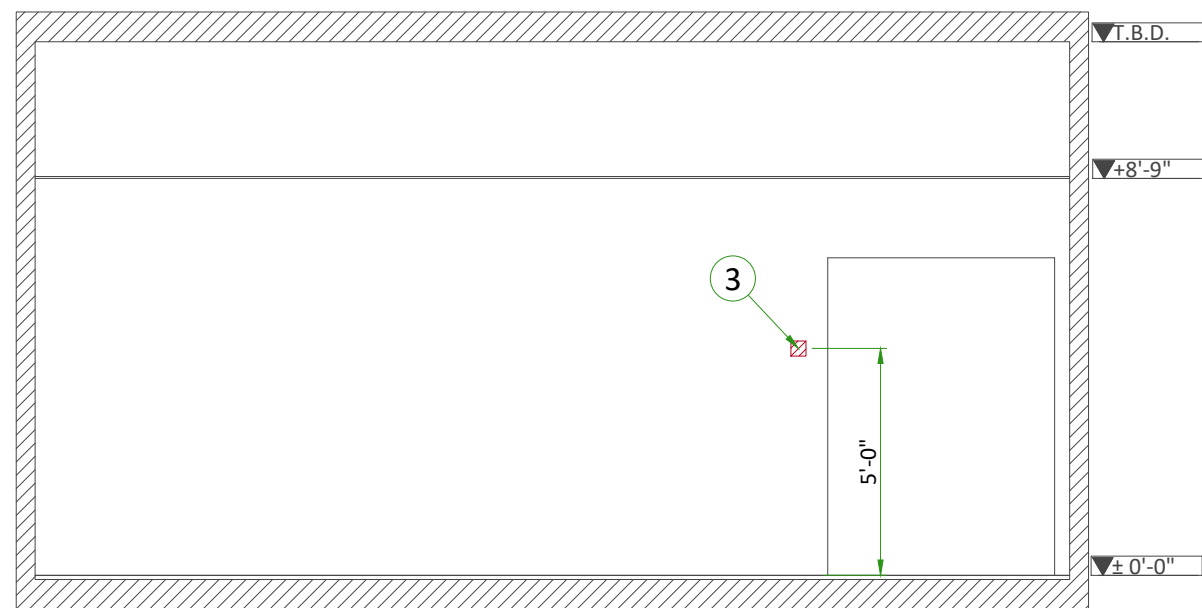

A

INTERCONNECTIONS

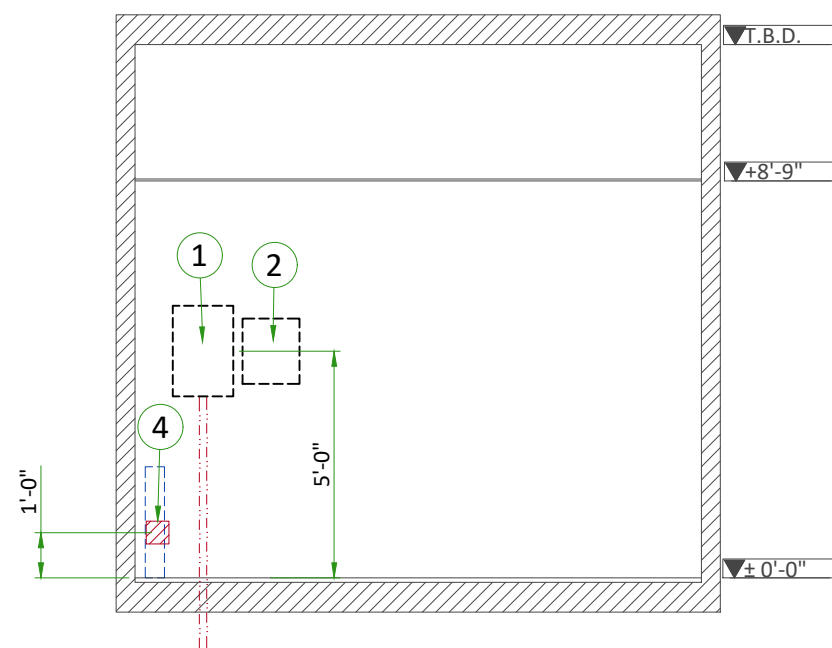
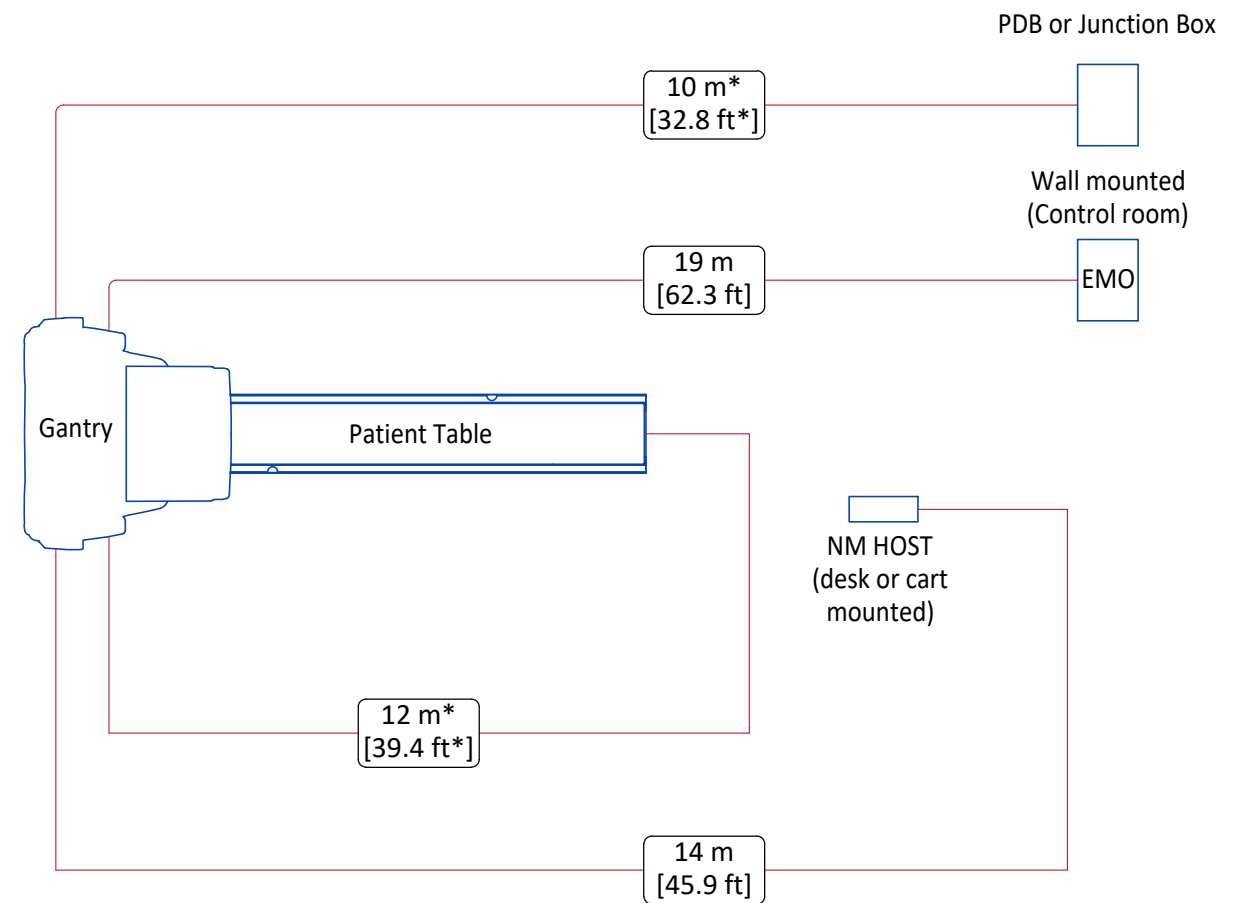

B

TYPICAL CABLE MANAGEMENT

CONDUIT IN THE FLOOR

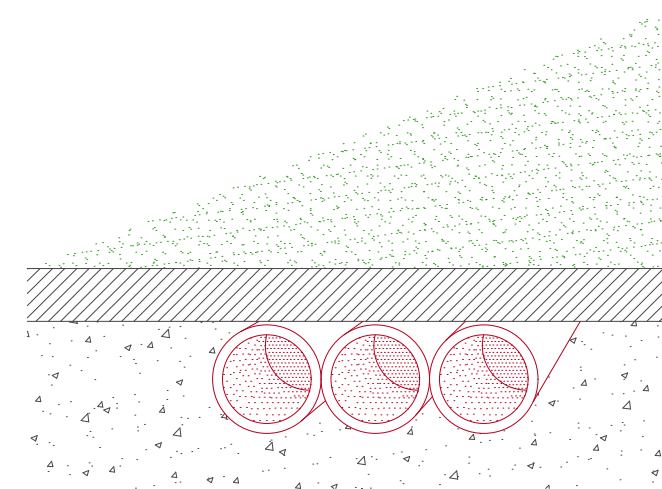

NOT TO SCALE

POWER REQUIREMENTS

POWER SUPPLY	SINGLE PHASE (G+L+N) OR DUAL PHASE (G+L1+L2) 175-250 VAC ±10%
FREQUENCIES	50/60 Hz ± 3 Hz
MAXIMUM POWER DEMAND	6 kVA
CONTINUOUS (AVERAGE) POWER DEMAND	3 kVA

- Line supply should come into a Main Disconnect Panel (MDP) containing the protective units and controls. The section of the supply cable should be calculated in accordance with its length and the maximum permissible voltage drops.
- There must be discrimination between supply cable protective material at the beginning of the installation (main low-voltage transformer side) and the protective devices in the MDP.

SUPPLY CHARACTERISTICS

- Power input must be separate from any others which may generate transients (elevators, air conditioning, radiology rooms equipped with high speed film changers ...)
- All equipment (lighting, power outlets, etc...) installed with GE system components must be powered separately.
- Phase imbalance 2% maximum.
- Maximum voltage regulation at full load = 6% (including line impedance)
- Transients must be less than 1500 V peak (on a 230 V line). A record of power input disturbances over a continuous one-week period (prior to delivery) enables determination of the frequency and degree of these disturbances and can be used to ascertain the need to provide line conditioning equipment.
- Inrush current can withstand up to 10 times the recommended circuit breaker rating that could be reached during system power up, due to the system main transformer.

GROUND SYSTEM

- Equipotential: The equipotential link will be by means of an equipotential bar. This equipotential bar should be connected to the protective earth conductors in the ducts of the non GE cableways and to additional equipotential connections linking up all the conducting units in the rooms where GE system units are located.

CABLES

- Power and cable installation must comply with the distribution diagram below.
- All cables must be isolated and flexible, cable color codes must comply with standards for electrical installation.
- The cables from signaling and remote control (Y, SEO, L ...) will go to MDP with a pigtail length of 1.5 m, and will be connected during installation. Each conductor will be identified and isolated (screw connector).

CABLEWAYS

The general rules for laying cableways should meet the conditions laid down in current standards and regulations, with regard to :

- Protecting cables against water (cableways should be waterproof)
- Protecting cables against abnormal temperatures (proximity to heating pipes or ducts)
- Protecting cables against temperature shocks
- Replacing cables (cableways should be large enough for cables to be replaced)
- Metal cableways should be grounded

POWER DISTRIBUTION

