

DISCLAIMER

GENERAL SPECIFICATIONS

- GE is not responsible for the installation of developers and associated equipment, lighting, cassette trays and protective screens or derivatives not mentioned in the order.
- The final study contains recommendations for the location of GE equipment and associated devices, electrical wiring and room arrangements. When preparing the study, every effort has been made to consider every aspect of the actual equipment expected to be installed.
- The layout of the equipment offered by GE, the dimensions given for the premises, the details provided for the pre-installation work and electrical power supply are given according to the information noted during on-site study and the wishes expressed by the customer.
- The room dimensions used to create the equipment layout may originate from a previous layout and may not be accurate as they may not have been verified on site. GE cannot take any responsibility for errors due to lack of information.
- Dimensions apply to finished surfaces of the room.
- Actual configuration may differ from options presented in some typical views or tables.
- If this set of final drawings has been approved by the customer, any subsequent modification of the site must be subject to further investigation by GE about the feasibility of installing the equipment. Any reservations must be noted.
- The equipment layout indicates the placement and interconnection of the indicated equipment components. There may be local requirements that could impact the placement of these components. It remains the customer's responsibility to ensure that the site and final equipment placement complies with all applicable local requirements.
- All work required to install GE equipment must be carried out in compliance with the building regulations and the safety standards of legal force in the country concerned.
- These drawings are not to be used for actual construction purposes. The company cannot take responsibility for any damage resulting therefrom.

CUSTOMER RESPONSIBILITIES

- It is the responsibility of the customer to prepare the site in accordance with the specifications stated in the final study. A detailed site readiness checklist is provided by GE. It is the responsibility of the customer to ensure all requirements are fulfilled and that the site conforms to all specifications defined in the checklist and final study. The GE Project Manager of Installation (PMI) will work in cooperation with the customer to follow up and ensure that actions in the checklist are complete, and if necessary, will aid in the rescheduling of the delivery and installation date.
- Prior to installation, a structural engineer of record must ensure that the floor and ceiling is designed in such a way that the loads of the installed system can be securely borne and transferred. The layout of additional structural elements, dimensioning and the selection of appropriate installation methods are the sole responsibility of the structural engineer. Execution of load bearing structures supporting equipment on the ceiling, floor or walls are the customer's responsibility.

RADIO-PROTECTION

- Suitable radiological protection must be determined by a qualified radiological physicist in conformation with local regulations. GE does not take responsibility for the specification or provision of radio-protection.

THE UNDERSIGNED, HEREBY CERTIFIES THAT I HAVE READ AND APPROVED THE PLANS IN THIS DOCUMENT.		
DATE	NAME	SIGNATURE

CUSTOMER SITE READINESS REQUIREMENTS

REQUIRED MANUALS FOR SYSTEM PRE-INSTALLATION

Description	Document Number*
Product specific Pre-installation Manual	Refer to cover page
*documents can be accessed in multiple languages at https://www.gehealthcare.com/support/manuals	

- A mandatory component of this drawing set is the GE HealthCare Pre-installation manual. Failure to reference the Pre-installation manual will result in incomplete documentation required for site design and preparation.
- The items on the GE HealthCare Site Readiness Checklist **DOC2949062** and Worksheet **DOC2949068** are **REQUIRED** to facilitate equipment delivery to the site. Equipment will not be delivered if these requirements are not satisfied.
 - Any deviation from these drawings must be communicated in writing to and reviewed by your local GE HealthCare installation project manager prior to making changes.
 - Make arrangements for any rigging, special handling, or facility modifications that must be made to deliver the equipment to the installation site. If desired, your local GE HealthCare installation project manager can supply a reference list of rigging contractors.
 - New construction requires the following;
 1. Secure area for equipment,
 2. Power for drills and other test equipment,
 3. Restrooms.
 - Provide for refuse removal and disposal (e.g. crates, cartons, packing)

ELECTROMAGNETIC INTERFERENCE

The IGS System is intended for use in the electromagnetic environment specified below. The Customer or the user of the System should assure that it is used in such an environment.

EMISSIONS	TEST COMPLIANCE	ELECTROMAGNETIC ENVIRONMENT
Radio-Frequency Emissions CISPR11	Group1 Class A limits	The IGS System uses Radio Frequency energy only for its internal function. Therefore, its Radio Frequency emissions are very low and are not likely to cause any interference in nearby electronic equipment.
		The IGS System is suitable for use in all establishments other than domestic and those directly connected to the public low-voltage power supply network that supplies buildings used for domestic purposes.
Harmonic emissions IEC 61000-3-2	Not applicable	The IGS System is suitable for use in all establishments other than domestic and those directly connected to the public low-voltage power supply network that supplies buildings used for domestic purposes.
Voltage fluctuations/ flicker emissions IEC 61000-3-3	Not applicable	The IGS System is suitable for use in all establishments other than domestic and those directly connected to the public low-voltage power supply network that supplies buildings used for domestic purposes.

RADIATION PROTECTION

Because X-ray equipment produces radiation, special precautions may be needed or special site modifications may be required. GE HealthCare does not make recommendations regarding radiation protection. It is the customer's responsibility to consult a radiation physicist for advise on radiation protection in x-ray rooms.

PERFORMIX PULSAR X-RAY TUBE SPECIFICATIONS	
Anode diameter	160 mm brazed graphite
Anode rotation	9600 rpm / 160 Hz
Anode target angle	11.25°
Anode heat storage capacity	12.3 MHUeff
Anode steady state heat dissipation	1100 KHU/min (13.5 kW)
Cathode	Tri-filament design
Coincidental focal spot sizes	0.3, 0.5 and 0.8
Fluoroscopic power	<ul style="list-style-type: none"> • 3200 W (continuous) • 4500 W (during 10 minutes)
Maximum casing heat storage	5.8 MJ (7.8 MHU)
Continuous casing heat storage	3200 W
Maximum anode cooling rate	1100 KHU/min (13.5 kW)
Permanent filtration	1.2 mm Al / 75 IEC 60522-1-2020
Leakage radiation (IEC 60601-1-3)	< 50 mR/hr at 125 kV and 25.6 mA

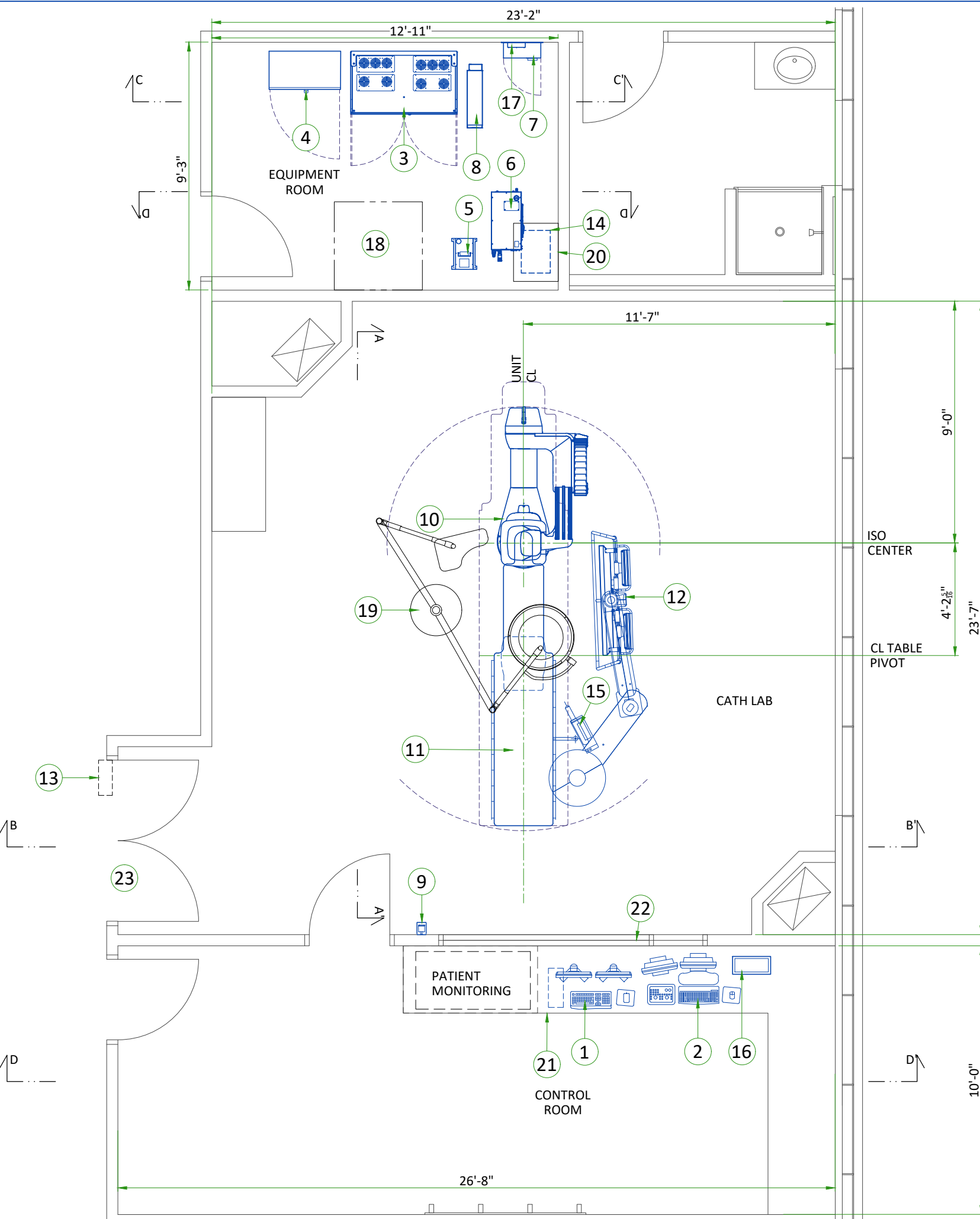

LEGEND

BY	ITEM	DESCRIPTION	MAX HEAT OUTPUT (BTU/h)	WEIGHT (lbs)	MAX HEAT OUTPUT (W)	WEIGHT (kg)
A	1	ADVANTAGE WORKSTATION (AW)	3412	70	1000	31.7
A	2	OPERATOR CONSOLE	341	31	100	14.05
A	3	C-FRT CABINET	7370	1153	2160	523
A	4	SYSTEM INTERFACE CABINET (SIC)	1706	540	500	245
A	5	DETECTOR CONDITIONER	717	32	210	14.6
A	6	TUBE COOLING UNIT	11840	144	3470	65.5
B	7	MAIN DISCONNECT PANEL (MDP)	-	49	-	22
A	8	11 kVA UPS	1774	174	520	78.8
A	9	XRAY BUZZER	-	2	-	1
A	10	LC GANTRY	5527	1625	1620	737
A	11	OMEGA V LONG PATIENT TABLE	-	1635	-	741.6
A	12	MAVIG LDM SUSPENSION WITH TWO BACKUP MONITORS	341	676	100	306.6
A	13	ELECTRICAL BOX (LIGHT SIGNALING - NOT SUPPLIED BY GE)	-	-	-	-
B	14	INJECTOR ELECTRONICS	-	37	-	17
A	15	INJECTOR HEAD	-	-	-	-
A	16	REMOTE CONTROL FOR INJECTOR	-	4	-	2
A	17	I-BOX	-	7	-	3
C	18	1000 x 1000 [39.4" x 39.4"] AREA REQUIRED FOR SYSTEM TOOLS AND DOCUMENTATION	-	-	-	-
C	19	SUSPENSION WITH SHIELD AND LAMP (NOT SUPPLIED BY GE)	-	-	-	-
C	20	SHELF	-	-	-	-
C	21	COUNTER TOP FOR EQUIPMENT- PROVIDE GROMMETED OPENINGS AS REQUIRED TO ROUTE CABLES	-	-	-	-
C	22	CONTROL WALL TO CEILING WITH LEAD GLASS VIEWING WINDOW	-	-	-	-
C	23	MINIMUM OPENING FOR EQUIPMENT DELIVERY IS 1160mm x 2438 mm [46 in x 87 in], CONTINGENT ON A 2438 mm [96 in] CORRIDOR WIDTH	-	-	-	-

EXAM ROOM HEIGHT

FINISHED FLOOR TO SLAB HEIGHT	TBD
FALSE CEILING HEIGHT	Rec. 9'-6"

For Accessory Sales: (866) 281-7545 Options 1, 2, 1, 2 or mail to: gehccaccessorysales@ge.com

EXAM ROOM VIEW

SECTION A-A'

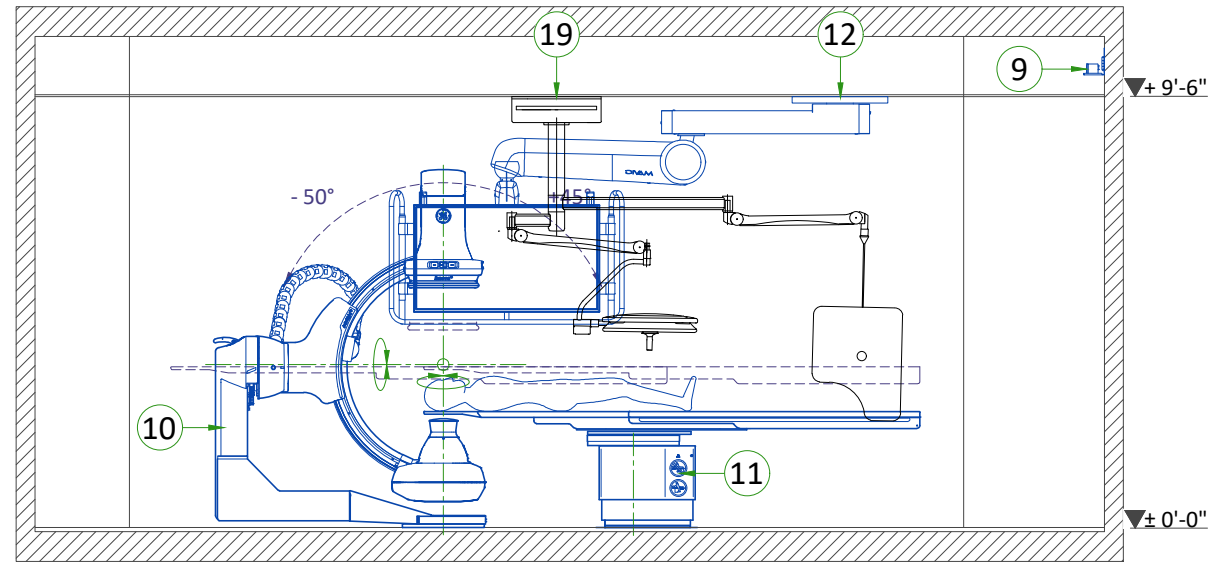

TECHNICAL ROOM VIEW

SECTION C-C'

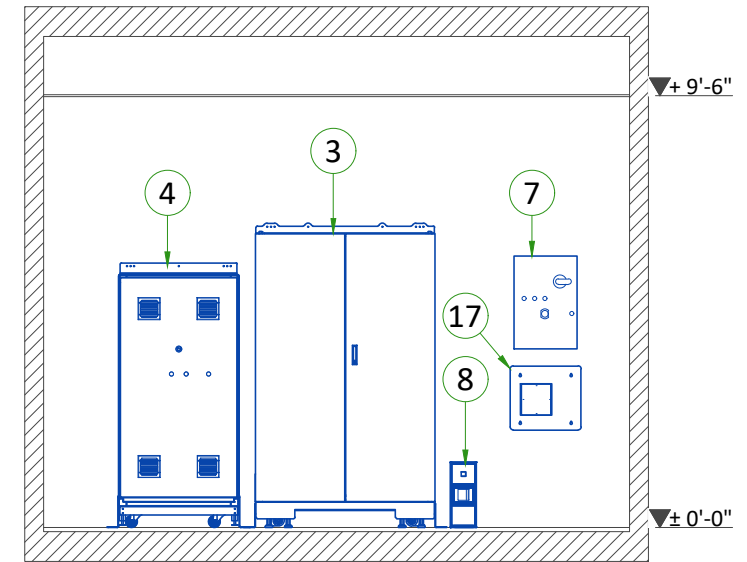

EXAM ROOM VIEW

SECTION B-B'

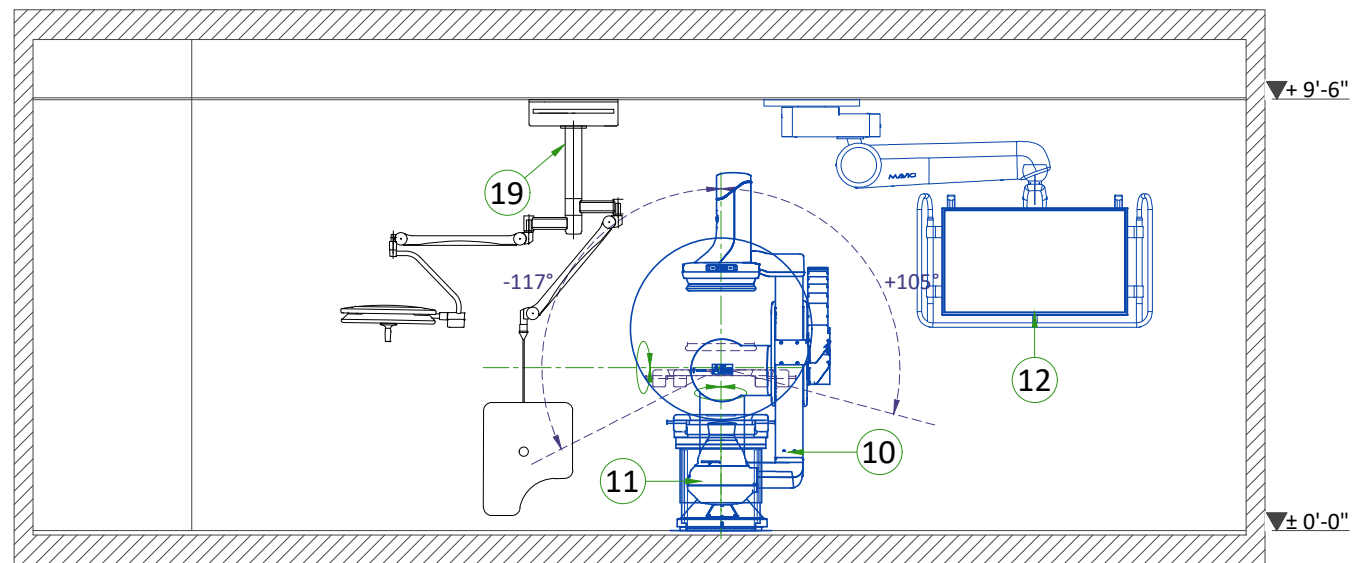

TECHNICAL ROOM VIEW

SECTION D-D'

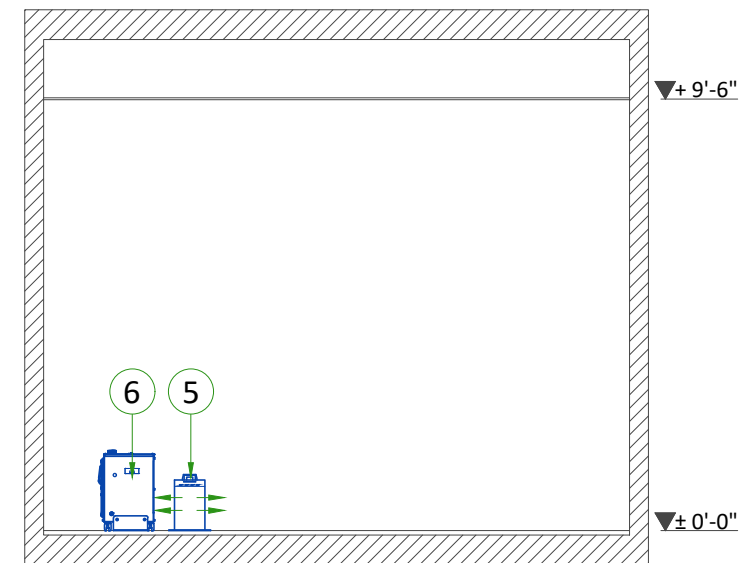

GANTRY

FRONT VIEW

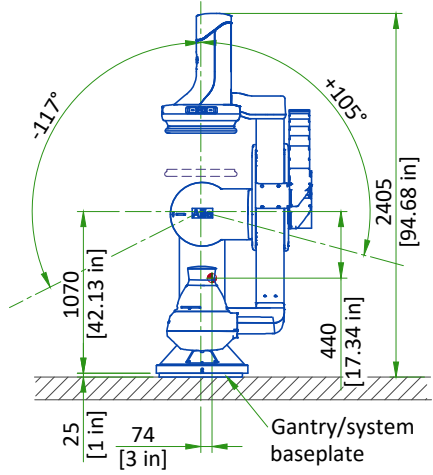

TOP VIEW

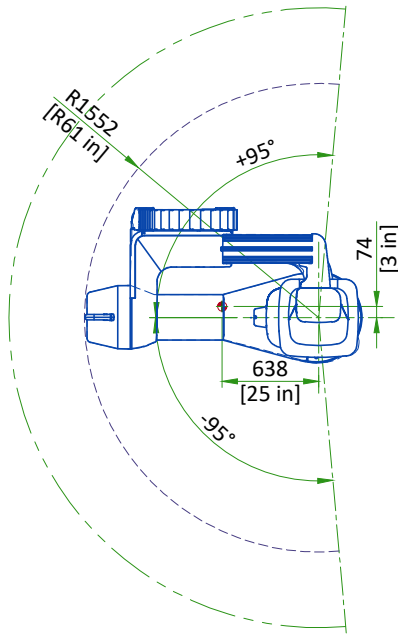

SIDE VIEW

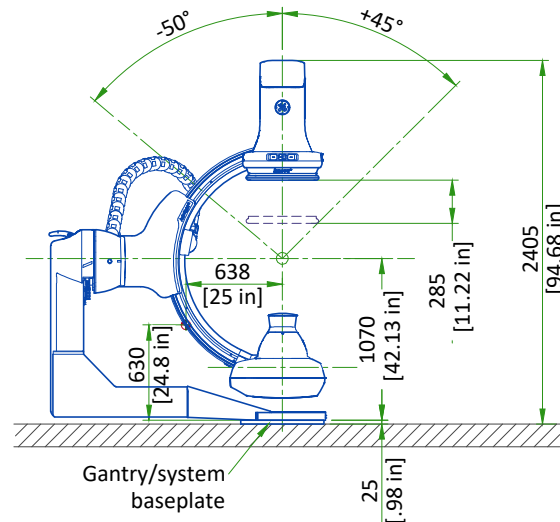

Center of Gravity

SCALE 1:50

8 kVA UPS or 11kVA FLUORO UPS

TOP VIEW

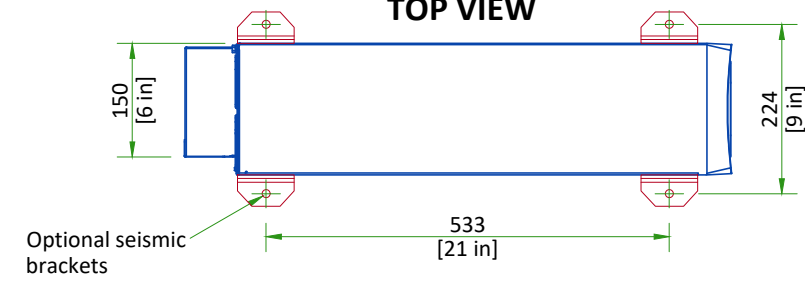

SIDE VIEW

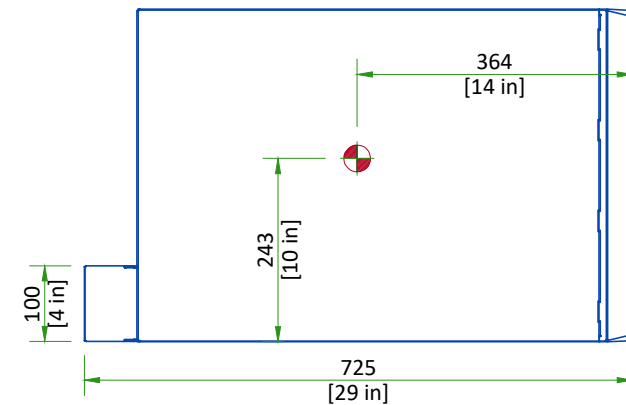

FRONT VIEW

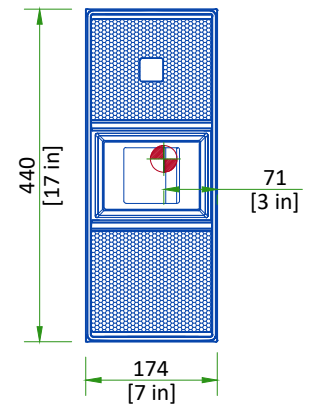

Center of Gravity

Scale 1:10

DETECTOR CONDITIONER

TOP VIEW

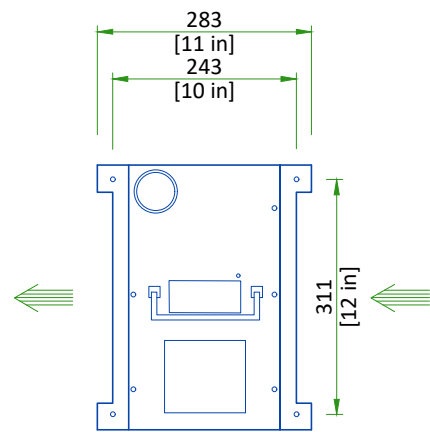

FRONT VIEW

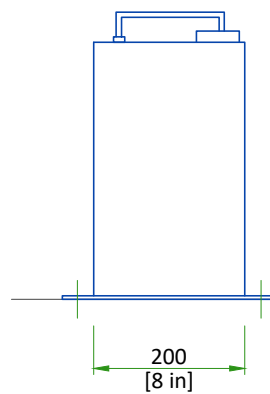

SIDE VIEW

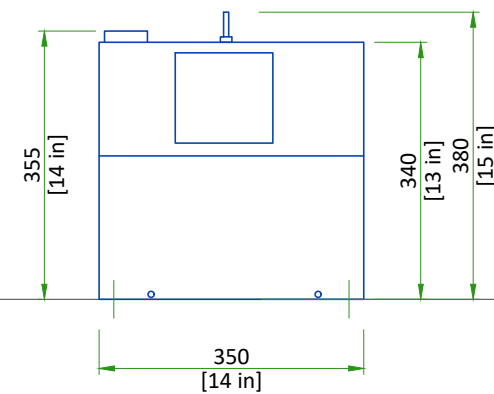

Indicates air flow

Scale 1:10

C-FRT CABINET

TOP VIEW

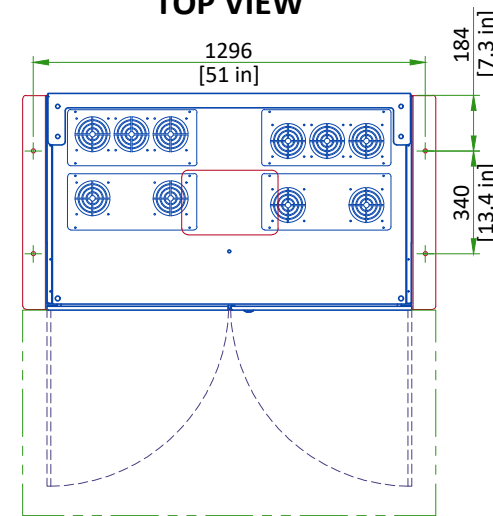

FRONT VIEW

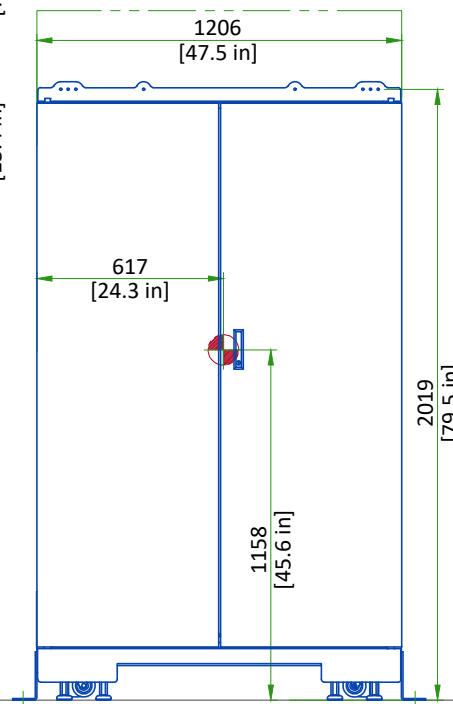

SIDE VIEW

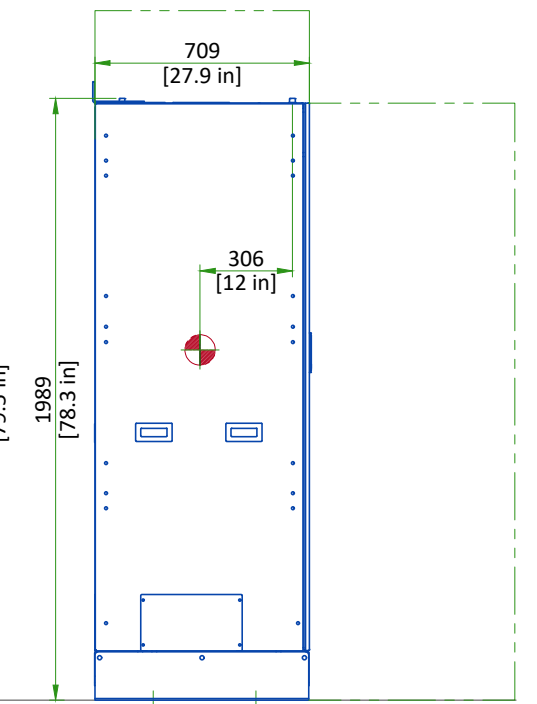

Center of Gravity

SCALE 1:25

MAIN DISCONNECT PANEL

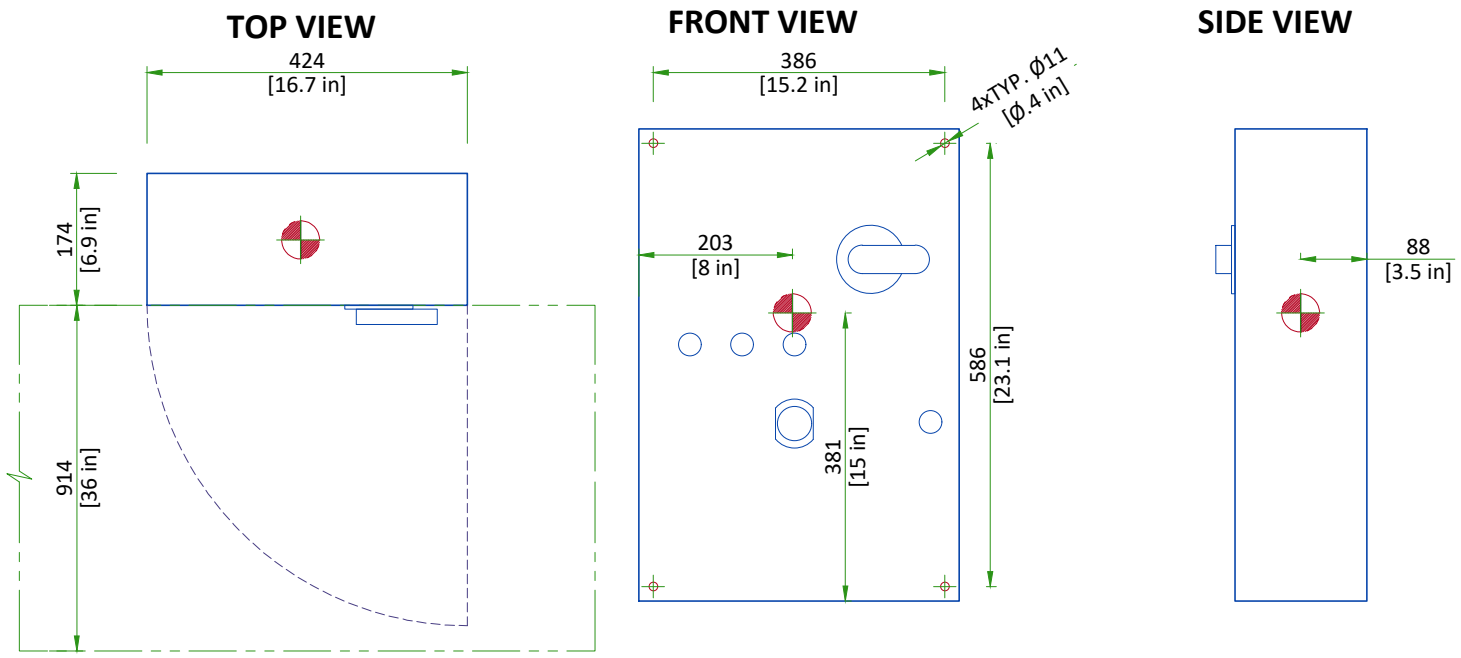

Center of Gravity

Scale 1:10

SYSTEM INTERFACE CABINET

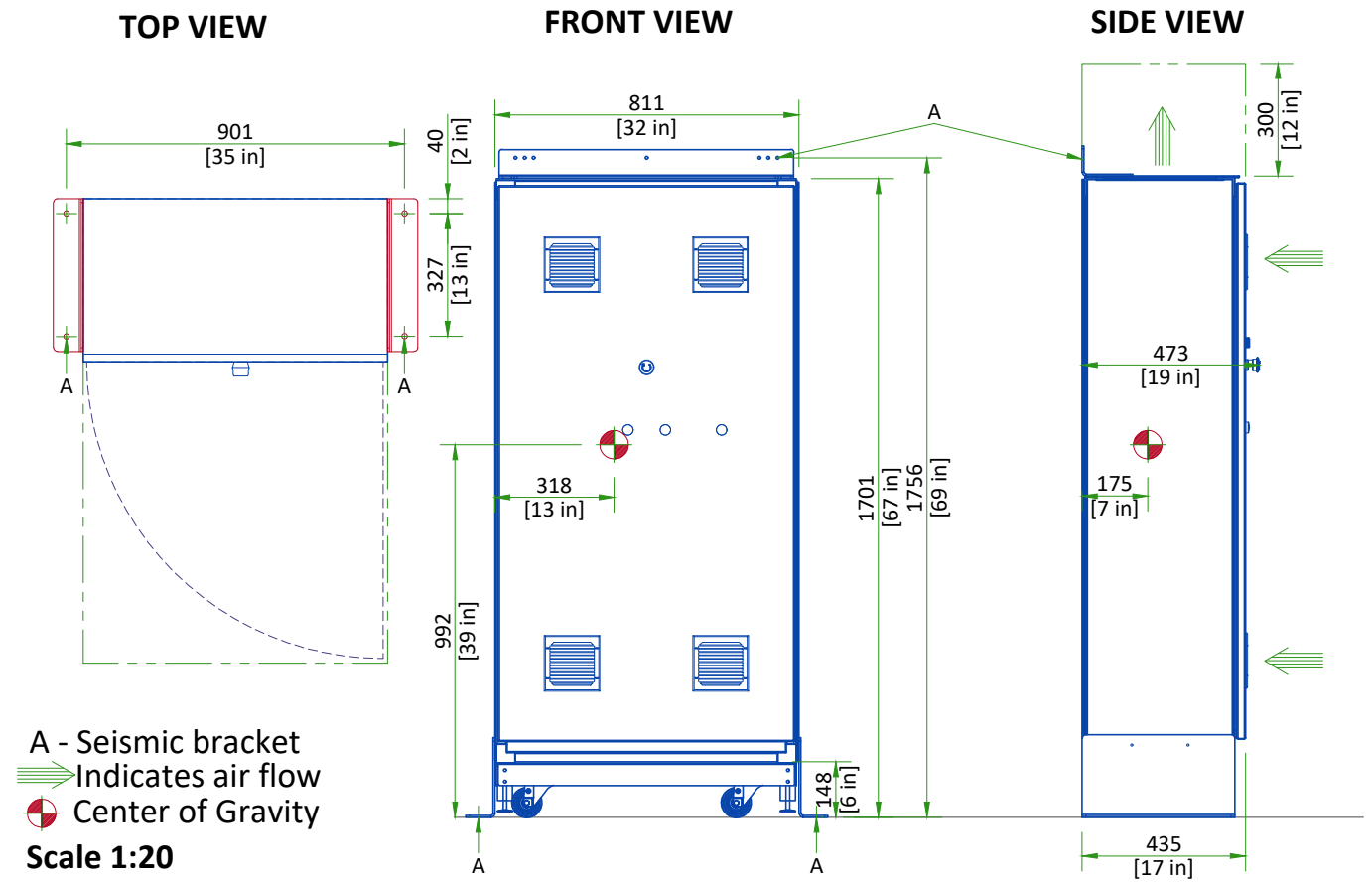

TUBE COOLING UNIT

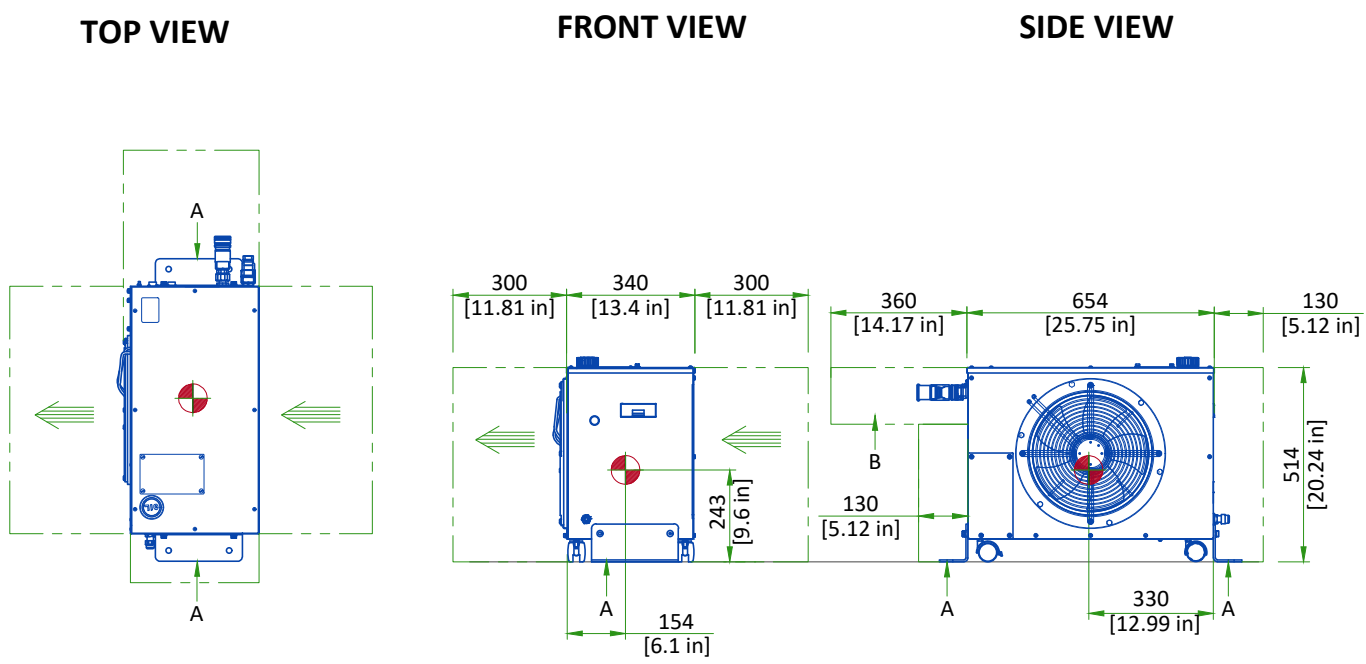

A - Seismic bracket
 B - Hydraulic connection
 Indicates air flow
 Center of Gravity
 Scale 1:20

OMEGA V PATIENT TABLE

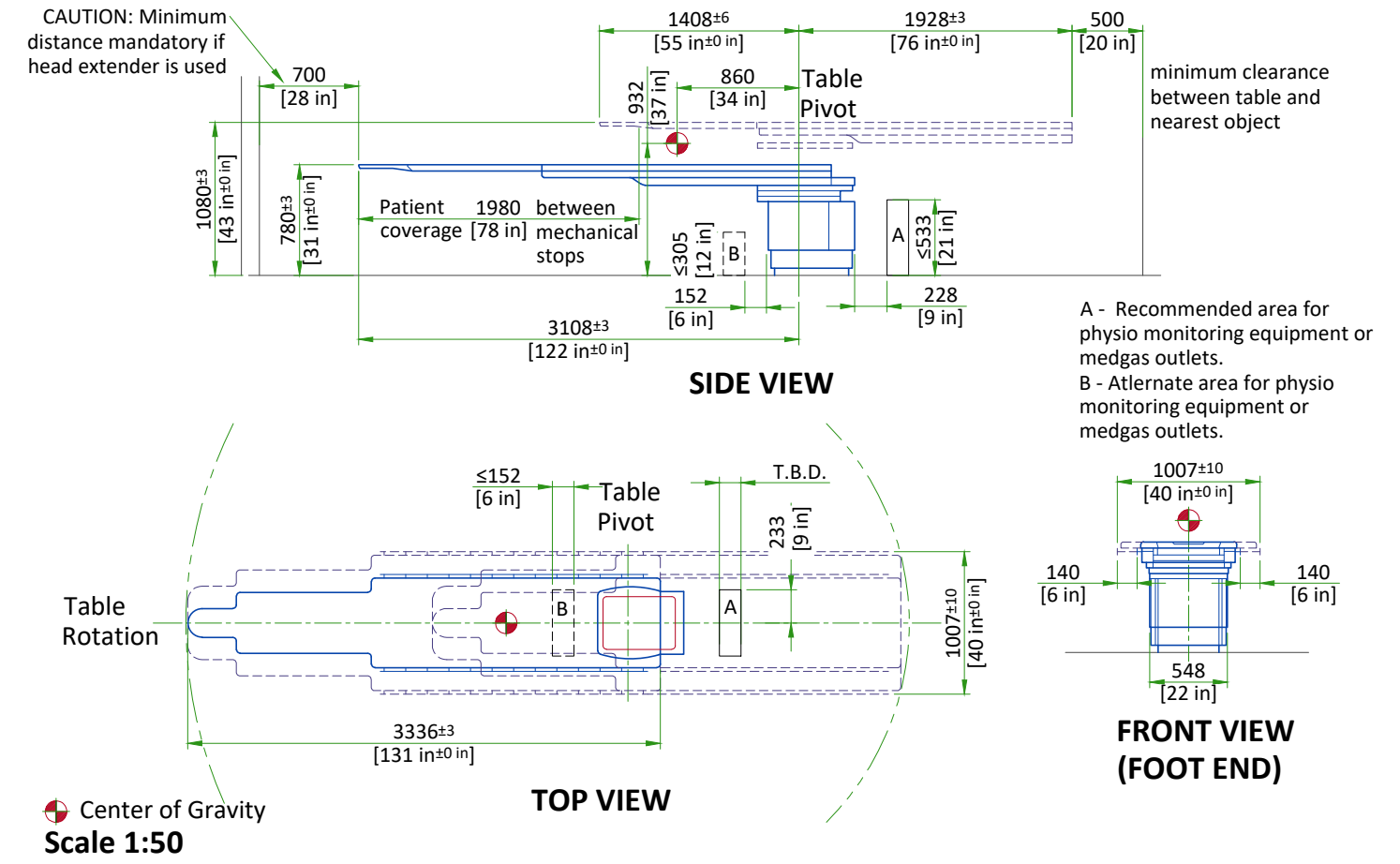

I-BOX AND X-RAY BUZZER

X-RAY BUZZER

Mounting:

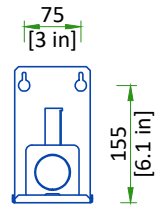

Top view:

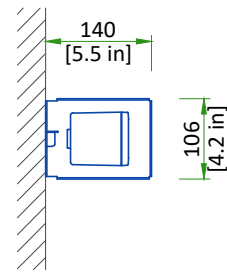

Side view:

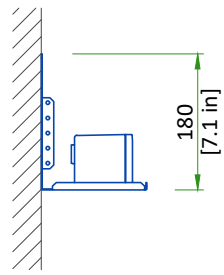

I-BOX

Mounting:

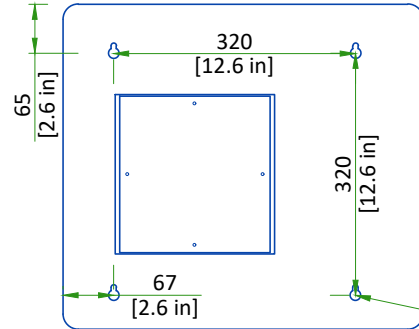

Top view:

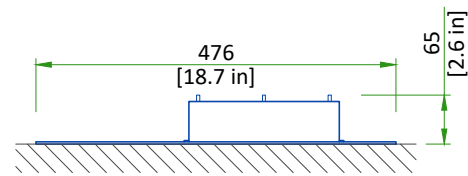

Side view:

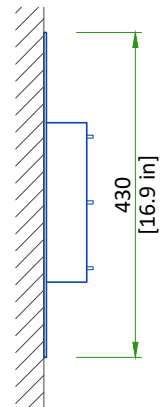

Fasteners supplied by customer and shall support a load of 15 kg [33 lb].

Scale 1:10

DELIVERY

THE CUSTOMER/CONTRACTOR SHOULD:

- Provide an area adjacent to the installation site for delivery and unloading of the GE equipment.
- Ensure that the dimensions of all doors, corridors, ceiling heights are sufficient to accommodate the movement of GE equipment from the delivery area into the definitive installation room.
- Ensure that access routes for equipment will accommodate the weights of the equipment and any transportation, lifting and rigging equipment.
- Ensure that all necessary arrangements for stopping and unloading on public or private property not belonging to the customer have been made.

DIMENSIONS OF DELIVERY

EQUIPMENT	DIMENSIONS		WEIGHT	
GANTRY (SHIPPING DOLLY)	LENGTH	2820 mm 111 in	940 kg 2072 lb	
	WIDTH	1230 mm 48.4 in		
	HEIGHT	2000 mm 79 in		
OMEGA TABLE BASE ASSEMBLY (ON PALLET)	LENGTH	2060 mm 81 in	585 kg 1290 lb	
	WIDTH	840 mm 33 in		
	HEIGHT	1035 mm 41 in		
C-FRT CABINET (ON PALLET)	LENGTH	850 mm 34 in	618.6 kg 1362 lb	
	WIDTH	1500 mm 59 in		
	HEIGHT	2200 mm 87 in		

RECOMMENDED AREA IN THE TECHNICAL ROOM

THE TECHNICAL ROOM NEED EXTRA SPACE FOR TOOLS AND DOCUMENTATION

- GEHC recommends an extra area of 1.0 x 1.0 m [39.4 x 39.4 in] for storage of tools and documentation for the system.
- This area doesn't need to be inside the technical room and can be located nearby.

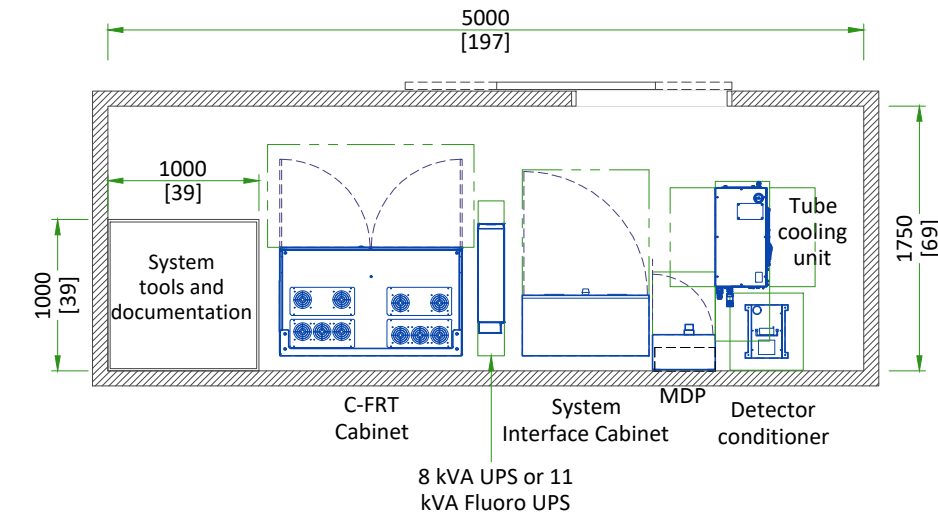

SHIPPING DOLLY FOR LC GANTRY

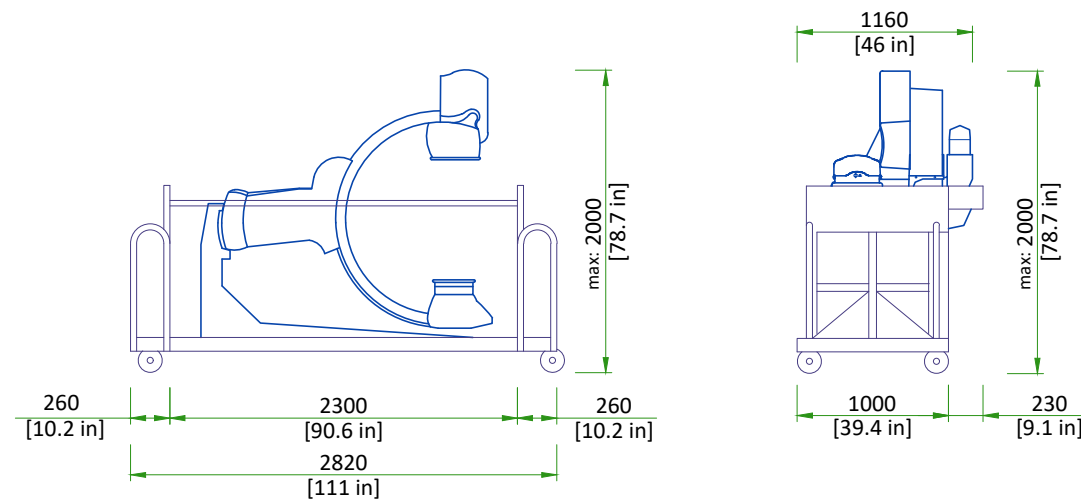

SHIPPING WEIGHT: 1060 kg [2337 lb].

Both ends of the dolly can be removed which will shorten the LC gantry dolly to 2300 mm [90 in], also the right and left top handles can be removed which will make the width 1160 mm [46 in].

SCALE 1:50

STRUCTURAL NOTES

- All steel work and parts necessary to support ceiling mounted tube hanger or other equipment are to be supplied by the customer or his contractors. The structural support should run continuous with no fittings extending below face of structural support channel, run wall to wall, be parallel, square and in the same horizontal plane flush with finished ceiling. The system is to be cross braced vertically, horizontally and diagonally to allow no movement and a maximum of 1,58mm [1/16"] deflection. **12.7mm [1/2"] dia. x 38.1mm [1 1/2"] long bolts with unistrut 12.7mm [1/2"] nuts with springs are to be provided by customer or his contractors for each stationary and auxillary support rail. Closure strips shall be provided for areas of unistrut exposed and without mounting units.**
- Methods of support for the steelwork that will permit attachment to structural steel or through bolts in concrete construction should be favored. Do not use concrete or masonry anchors in direct tension.
- All units that are wall mounted or wall supported are to be provided with supports where necessary. Wall supports are to be supplied and installed by the customer or his contractors. See plan and detail sheets for suggested locations and mounting hole locations.
- All ceiling mounted fixtures, air vents, sprinklers, etc. To be flush mounted, or shall not extend more than 6.35mm [1/4"] below the finished ceiling.
- Control walls with tube hanger passage above shall be constructed to 2130mm [7'-0"] high.
- Dimensions are to finished surfaces of room.
- Customers contractor must provide all penetrations in post tension floors.
- Customers contractor must provide and install any non-standard anchoring. Documents for standard anchoring methods are included with GEHC equipment drawings for geographic areas that require such documentation.
- Customers contractor must provide and install hardware for "through the floor" anchoring and/or any bracing under access floors. This contractor must also provide floor drilling that cannot be completed because of an obstruction encountered while drilling by the GEHC installer such as rebar etc.
- It is the customer's responsibility to perform any floor or wall penetrations that may be required. The customer is also responsible for ensuring that no subsurface utilities (e.g., electrical or any other form of wiring, conduits, piping, duct work or structural supports (i.e. post tension cables or rebar)) will interfere or come in contact with subsurface penetration operations (e.g. drilling and installation of anchors/screws) performed during the installation process. To ensure worker safety, GEHC installers will perform surface penetration operations only after the customer's validation and completion of the "GEHC surface penetration permit"

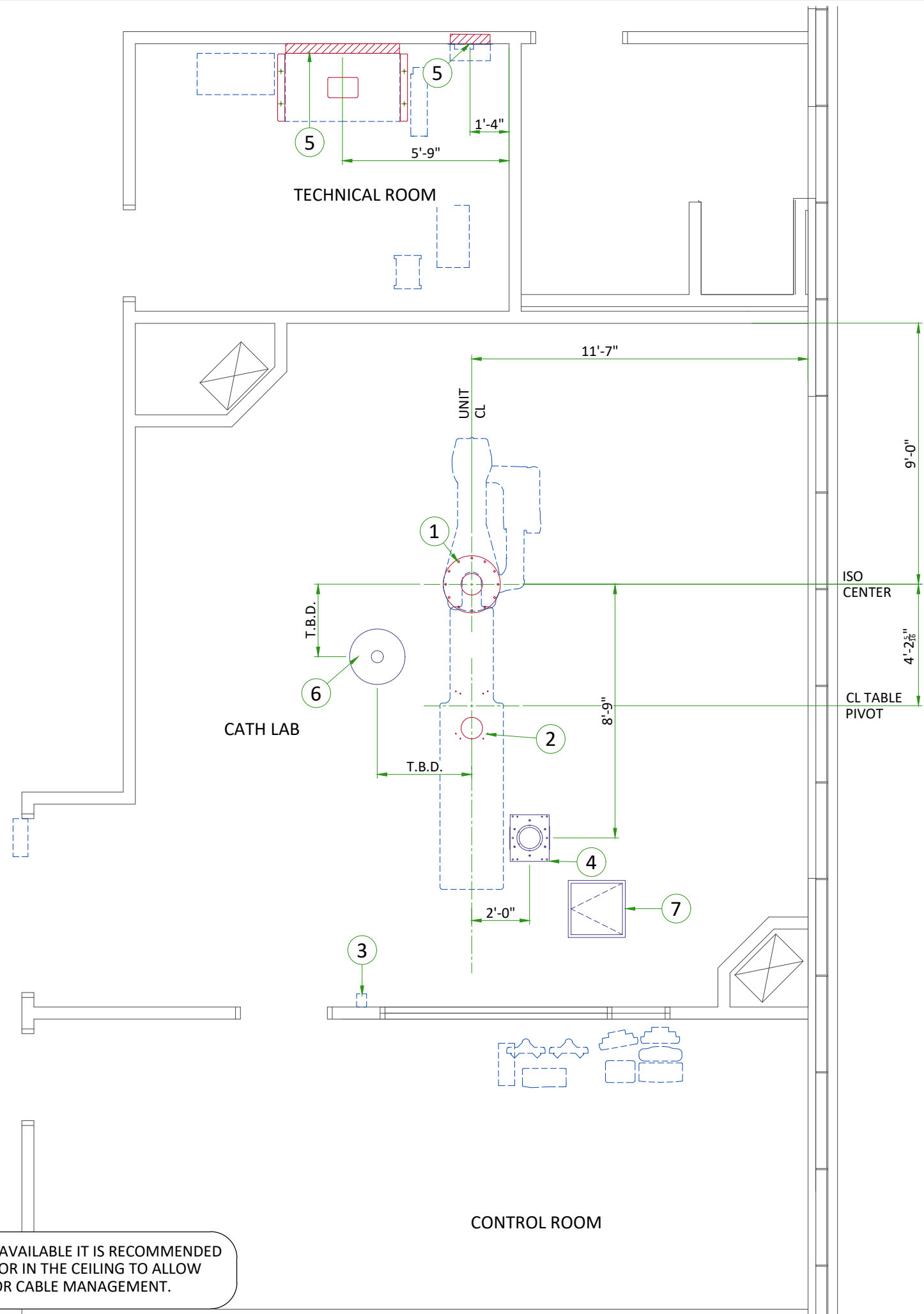

STRUCTURAL LAYOUT ITEM LIST

(GE SUPPLIED / CONTRACTOR INSTALLED)

1	Area occupied by GE supplied positioner baseplate
2	Area occupied by GE supplied table baseplate
3	Mount X-Ray buzzer bracket on wall below ceiling

(CUSTOMER SUPPLIED / CONTRACTOR INSTALLED)

4	Structural support in ceiling for Mavig dual-arm suspension. Maximum Ø620mm [24.4 in] opening required in finished ceiling for lifting fixture access. Refer to Structural Detail.
5	Support backing, locate as shown.
6	Structural support in ceiling for vendor boom
7	600 x 600 [24" x 24"] Service access in ceiling

IF ACCESS IS NOT READILY AVAILABLE IT IS RECOMMENDED TO PROVIDE A TRAPDOOR IN THE CEILING TO ALLOW SERVICE ACCESS FOR CABLE MANAGEMENT.

LC GANTRY AND TABLE ANCHORING WITH NO BASEPLATE

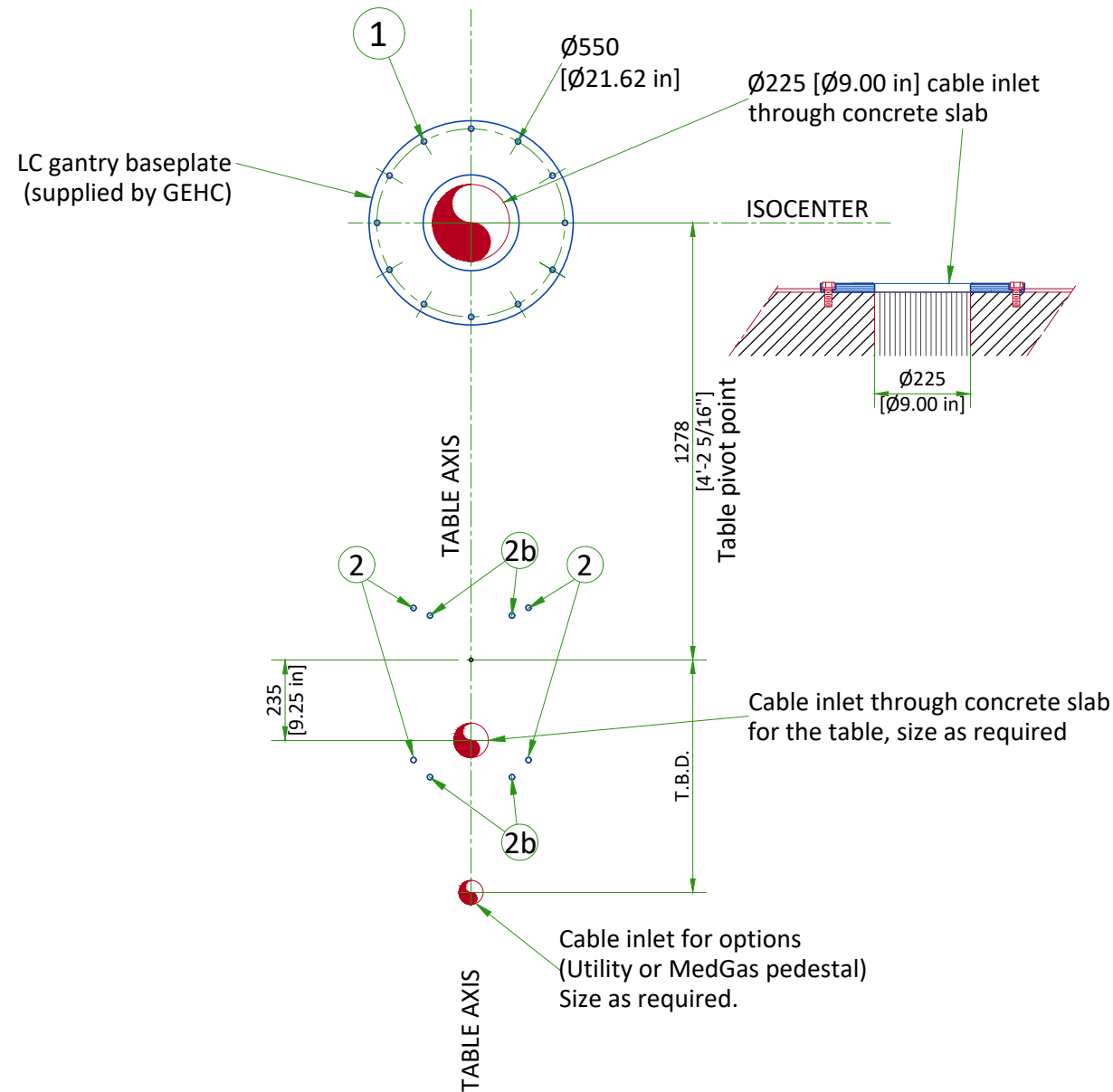

- 1 LC baseplate mounting location : 12 bolts
 Pullout strength on each bolt 736 daN
 - M20 Through-Bolts recommended (supplied by GEHC)
 Alternates:
 - M16 Mechanical anchors (supplied by GEHC)
 - Chemical anchors (not supplied by GEHC):
 HILTIHVU adhesive capsule + HAS Anchor rod
- 2 Table mounting location : 4 bolts required
 Pullout strength on each bolt 4432 daN
 - M20 Through-Bolts recommended (supplied by GEHC)
 Alternates:
 - M16 Mechanical anchors (supplied by GEHC)
 - Chemical anchors (not supplied by GEHC):
 HILTIHVU adhesive capsule + HAS Anchor rod
- 2b Alternate bolt holes for seismic zones 1 and 2

FLOOR REQUIREMENTS AND CABLE MANAGEMENT

FLOOR REQUIREMENTS

- The maximum pullout force per GEHC supplied anchor was calculated assuming :
 - A concrete compression strength of **17.24 MPa** at 28 days (which is the minimum required compression strength).
 - Anchors installed to the required hole depth of **165.1 mm [6.5 in] minimum**.
 - Center of anchor hole to concrete edge distance **79.4 mm [3.1 in]**.
 - Make sure to obtain data on compression strength of the concrete before using floor anchors.
- The floor level cannot exceed a general levelness of 5 mm [0.2 in] for any 2 meters [79 in].
- The floor slabs on which the equipment is to be installed must have a levelness of 1 mm [0.04 in] per meter [40 in].
- If applicable: grout below LC gantry baseplate shall be at least 3 mm [1/8 in] thick and be level within 0.8 mm [1/32 in].
- Anchoring to the floor is intended to the structural elements and not to common screed/finished floor.

CONDUIT IN/UNDER THE FLOOR

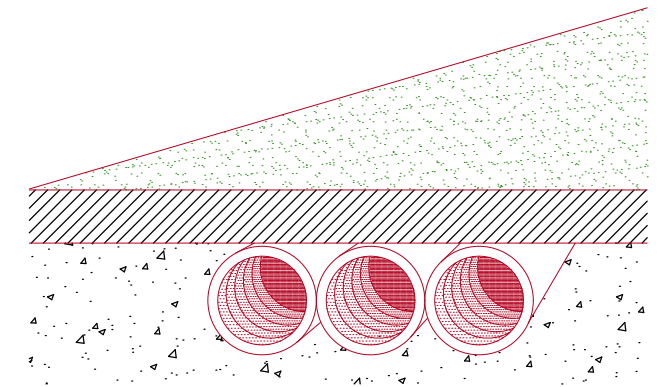

JUNCTION BOX BELOW FLOOR

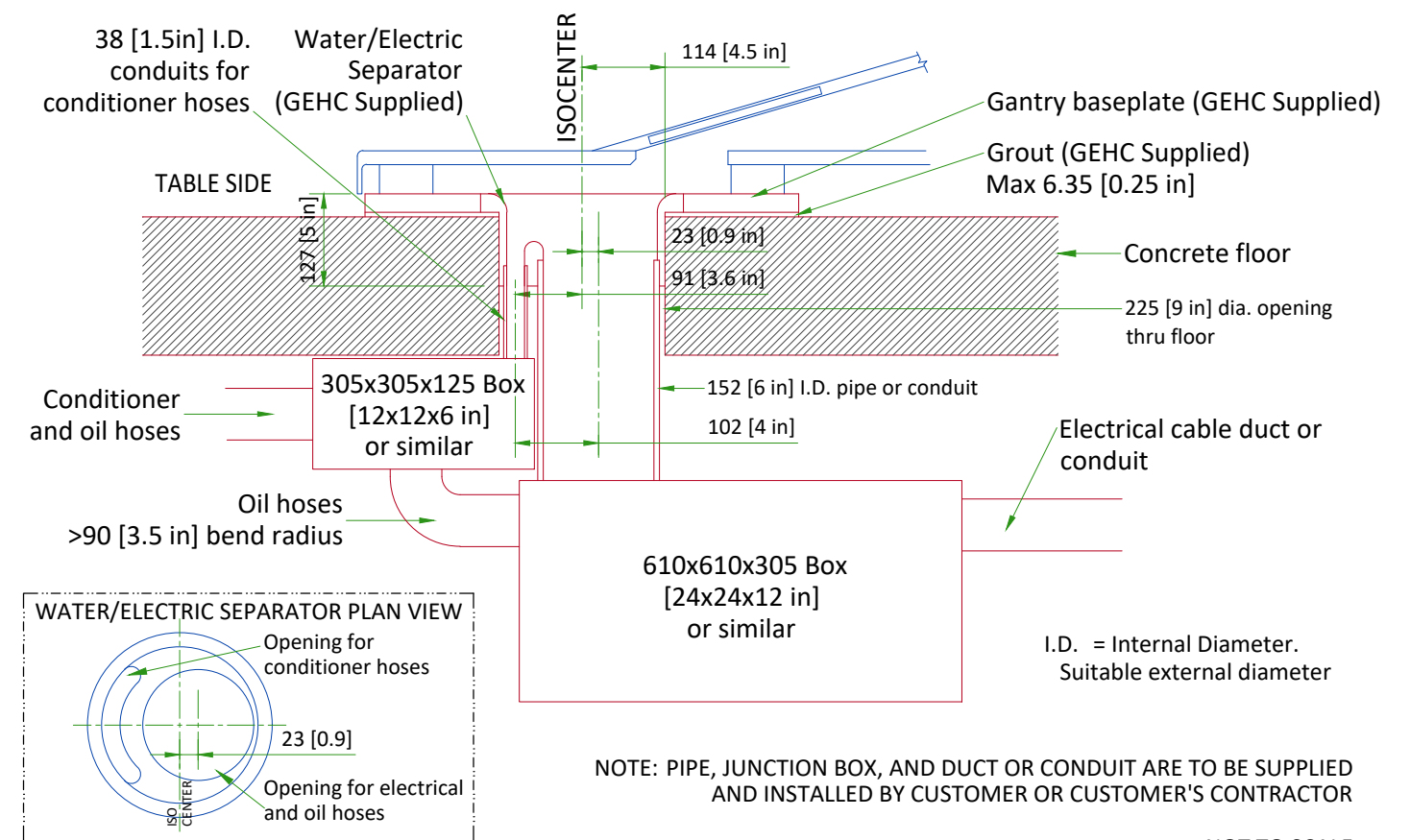

I.D. = Internal Diameter.
 Suitable external diameter

NOTE: PIPE, JUNCTION BOX, AND DUCT OR CONDUIT ARE TO BE SUPPLIED AND INSTALLED BY CUSTOMER OR CUSTOMER'S CONTRACTOR

NOT TO SCALE

MAVIG FIX MONITOR SUSPENSION MOUNTING METHOD

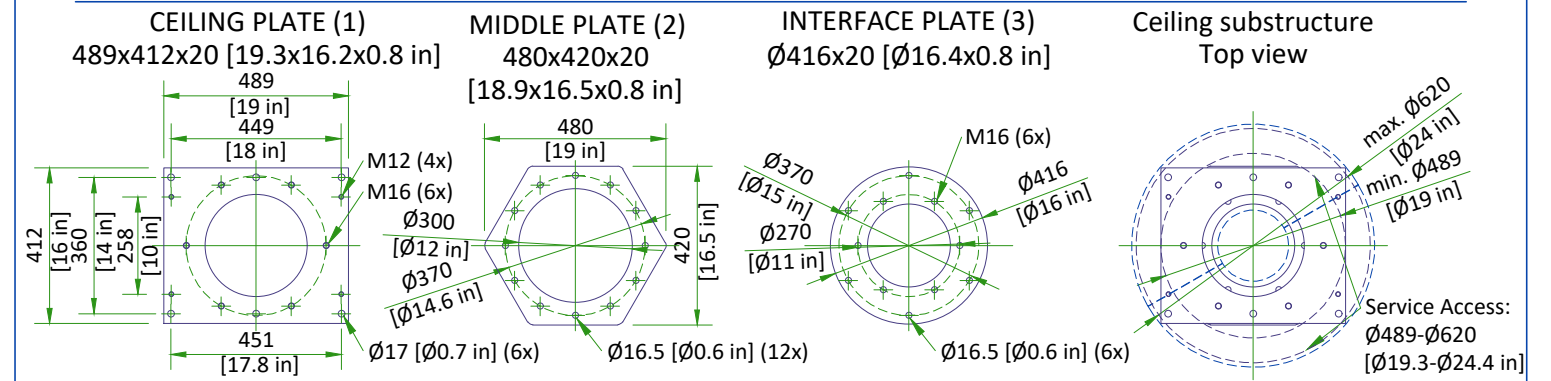

- | | |
|--|--|
| <p>CAUTION</p> <ul style="list-style-type: none"> The maximum axial load per bolt : 7210 N The maximum shear load per bolt : 957 N The max. pull out force is defined in accordance with local codes | <p>NOTE</p> <ul style="list-style-type: none"> steel threaded pins & nuts threads (supplied by customer) screws secured with Loctite 270 glue |
|--|--|

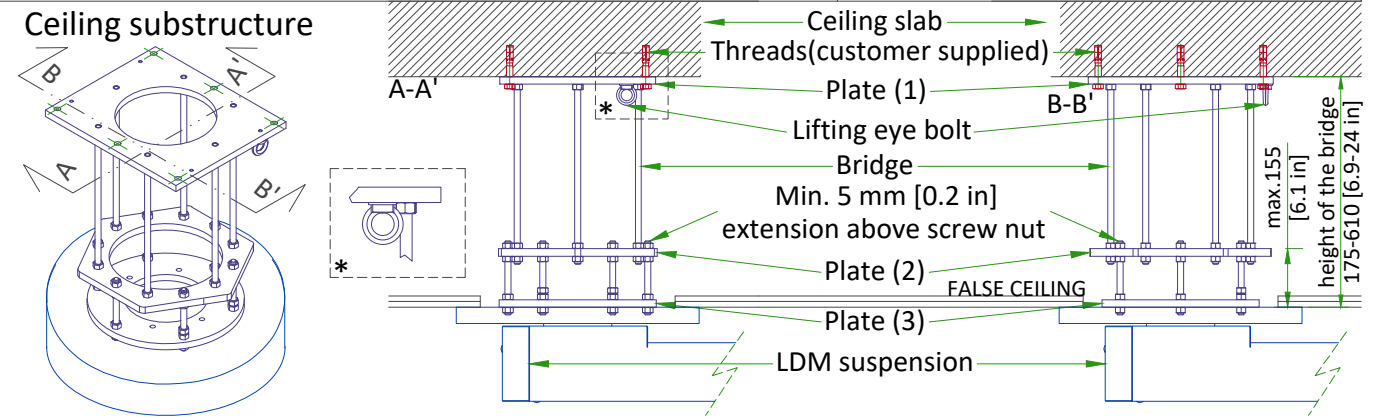

CEILING SUSPENSION DISCLAIMER

Safety and precautionary comments:

Only qualified, licensed technicians can perform electrical connections, installation, removal and repair. It is strongly recommended that at least two persons perform the installation.

Installing the system: Prior to installation, a structural engineer must confirm that the mounting structure is strong enough to provide proper support for the entire system and any attached end devices. Installation must be completed according to local building codes.

Determination of required installation hardware and torque values for installation of the ceiling column and ceiling track is the sole responsibility of the structural engineer.

Ceiling mounted systems must be installed properly. Failure to follow the instructions provided may lead to a potentially dangerous and unstable condition of the system.

GE and/or MAVIG is not responsible for unauthorized modifications made to the system or use of the system for unintended purposes. GE and/or MAVIG cannot be held liable for improper operation and modifications. Since improper modifications may impair proper operation, safety or reliability of the system, product modifications require written authorization from MAVIG.

Under GE responsibility or under Customer responsibility, for all pre-installations, whatever is the supporting structure (bridge, chair, Unistrut channel, other channels, direct anchorage in concrete, transversal beam, etc. ...) a certificate must be obtained from a structural engineer.

This certificate shall include the definition of fasteners and of their tightening torque, especially for the non-standard cases described in MAVIG PIM and for which the standard anchoring/screws delivered with product shall not be used but shall be defined (and implemented in most cases) by the structural company.

WARNING:

It is prohibited to alter the length of the ceiling column or remove any securing screws.

TEMPERATURE AND HUMIDITY SPECIFICATIONS

IN-USE CONDITIONS

	EXAM ROOM			CONTROL ROOM			TECHNICAL ROOM		
	Min	Recommended	Max	Min	Recommended	Max	Min	Recommended	Max
Temperature	15 °C [59 °F]	20 °C [68 °F]	32 °C [90 °F]	15 °C [59 °F]	20 °C [68 °F]	35 °C [95 °F]	15 °C [59 °F]	20 °C [68 °F]	25 °C [77 °F]
Temperature gradient	≤ 10 °C/h			≤ 10 °C/h			≤ 10 °C/h		
RH (1) non condensing	20% to 70%			20% to 75%			20% to 75%		
Humidity gradient	≤ 10%/h			≤ 10%/h			≤ 10%/h		

STORAGE CONDITIONS

Temperature	+10 °C [50 °F] to +40 °C [104 °F]
RH (1) non condensing	10% to 80%
Pressure	700 hPa to 1030 hPa
Overall storage time shall be less than 6 months.	

(1) Relative humidity

AIR RENEWAL

According to local standards.

NOTE

In case of using air conditioning systems that have a risk of water leakage it is recommended not to install it above electric equipment or to take measures to protect the equipment from dropping water.

8 kVA or 11 kVA Fluoro UPS

Systems with these UPS models shall be stored for less than 14 weeks if the storage temperature is above +30°C [86°F], and less than 25 weeks if storage temperature is above +25 °C [77°F].

HEAT DISSIPATION

ROOM	DESCRIPTION	HEAT OUTPUT (kW)				HEAT OUTPUT (BTU/hr)			
		STAND BY	MODERATE ¹	TYPICAL ²	MAX ³	STAND BY	MODERATE ¹	TYPICAL ²	MAX ³
Exam room	Gantry and table	0.41	0.55	0.89	1.62	1399	1877	3037	5528
	Large Display Monitor (LDM) with 2 backups	0.10	0.10	0.10	0.10	341	341	341	341
	Typical injector	0.09	0.09	0.09	0.09	307	307	307	307
	TOTAL	0.60	0.74	1.08	1.81	2047	2525	3685	6176
Control room	DL console and live monitor	0.10	0.10	0.10	0.10	341	341	341	341
	Advantage workstation (AW)	-	-	-	1.00	-	-	-	3412
	TOTAL	0.10	0.10	0.10	1.10	341	341	341	3753
Technical room	C-FRT Cabinet	0.70	1.02	1.53	2.16	2388	3480	5221	7370
	System Interface Cabinet	0.50	0.50	0.50	0.50	1706	1706	1706	1706
	Tube Cooling Unit	0.56	2.57	2.77	3.47	1927	8769	9482	11857
	Detector Conditioner	0.21	0.21	0.21	0.21	717	717	717	717
	UPS 8 kVA/Fluoro UPS 11 kVA	0.52	0.52	0.52	0.52	1774	1774	1774	1774
TOTAL	2.49	4.82	5.53	6.86	8512	16446	18900	23424	

WARNING

The list contains only the principal components of the system and doesn't contain any non-GEHC supplied equipment.

¹ Moderate Use corresponds to 8 cases in 10 hours.

² Typical Use corresponds to 11 cases in 10 hours.

³ Maximum Use is during the case.

ELECTRICAL NOTES

1. Aluminum or solid wires are not allowed.
2. Wire sizes given are for use of equipment. Larger sizes may be required by local codes.
3. It is recommended that all wires be color coded, as required in accordance with national and local electrical codes.
4. Conduit sizes shall be verified by the architect, electrical engineer or contractor, in accordance with local or national codes.
5. Convenience outlets are not illustrated. Their number and location are to be specified by others. Locate at least one convenience outlet close to the system control, the power distribution unit and one on each wall of the procedure room. Use hospital approved outlet or equivalent.
6. General room illumination is not illustrated. Caution should be taken to avoid excessive heat from overhead spotlights. Damage can occur to ceiling mounting components and wiring if high wattage bulbs are used. Recommend low wattage bulbs no higher than 75 watts and use dimmer controls (except MR). Do not mount lights directly above areas where ceiling mounted accessories will be parked.
7. Routing of cable ductwork, conduits, etc., must run direct as possible otherwise may result in the need for greater than standard cable lengths (refer to the interconnection diagram for maximum usable lengths point to point).
8. Conduit turns to have large, sweeping bends with minimum radius in accordance with national and local electrical codes.
9. In some cases GEHC will specify ground wires to be sized larger than code. In these situations, the GEHC specification must be followed.
10. A special grounding system is required in all procedure rooms by some national and local codes. It is recommended in areas where patients might be examined or treated under present, future, or emergency conditions. Consult the governing electrical code and confer with appropriate customer administrative personnel to determine the areas requiring this type of grounding system.
11. The maximum point to point distances illustrated on this drawing must not be exceeded.
12. Physical connection of primary power to GEHC equipment is to be made by customers electrical contractor with the supervision of a GEHC representative. The GEHC representative would be required to identify the physical connection location, and insure proper handling of GEHC equipment.
13. GEHC conducts power audits to verify quality of power being delivered to the system. The customer's electrical contractor is required to be available to support this activity.
14. Every installation is unique. The electrical contractor will be required to support the installation of the GEHC equipment by providing knockouts, grommeted openings, bushings, etc. as required. All power connections to be performed by the electrician.

- All junction boxes, conduit, duct, duct dividers, switches, circuit breakers, cable tray, etc., are to be supplied and installed by customers electrical contractor. All junction boxes shall be provided with covers.
- Conduit and duct runs shall have gradual sweep radius bends.
- Conduits and duct above ceiling or below finished floor must be installed as near to ceiling or floor as possible to reduce run length.
- Ceiling mounted junction boxes illustrated on this plan must be installed flush with finished ceiling.
- All ductwork must meet the following requirements:
 1. Ductwork shall be metal with dividers and have removable, accessible covers.
 2. Ductwork shall be certified/rated for electrical power purposes.
 3. Ductwork shall be electrically and mechanically bonded together in an approved manner.
 4. PVC as a substitute must be used in accordance with all local and national codes.
- All openings in raceway and access flooring are to be cut out and finished off with grommet material by the customers contractor.
- Electrical contractor to provide measured pull strings in all conduit and raceway runs.
- Provide 10 foot pigtailed at all junction points.
- Grounding is critical to equipment function and patient safety. Site must conform to wiring specifications shown on this plan.

CONNECTIVITY REQUIREMENTS

Service Connectivity for new systems will be based on the Insite-RSvP Platform which allows to configure a direct Internet connection to the RSvP Server (routers/VPN tunnel no more mandatory). Communication with the RSvP server will be outbound only and require using Transport Layer Security (TLS) over TCP port 443. This is commonly known as an HTTPS (HTTP-Secure) connection.

There will be several ways to connect the system to the RSvP Enterprise Server. See below the main options that might not be all available or authorized at your site depending on actual network constraints or local regulations.:

- The system allows for DNS configuration or proxy server-based connection to the Internet.
- Connection thru a GE Proxy will be possible in the future.
- In the case the customer does not accept the above connection protocol or regulatory reasons prevent using these types of configurations, the local/regional connectivity teams can provide help to connect through SSL/TLS proxy IP over the site-to-site VPN.

To make the system connectivity operational before the system installation is finished, ensure the connectivity solution is defined as early as possible during the pre-installation process and proper information are exchanged between the customer Network Administrators and GEHC Sales and/or Service representatives.

For more information please refer to the latest version of the Pre Installation Manual.

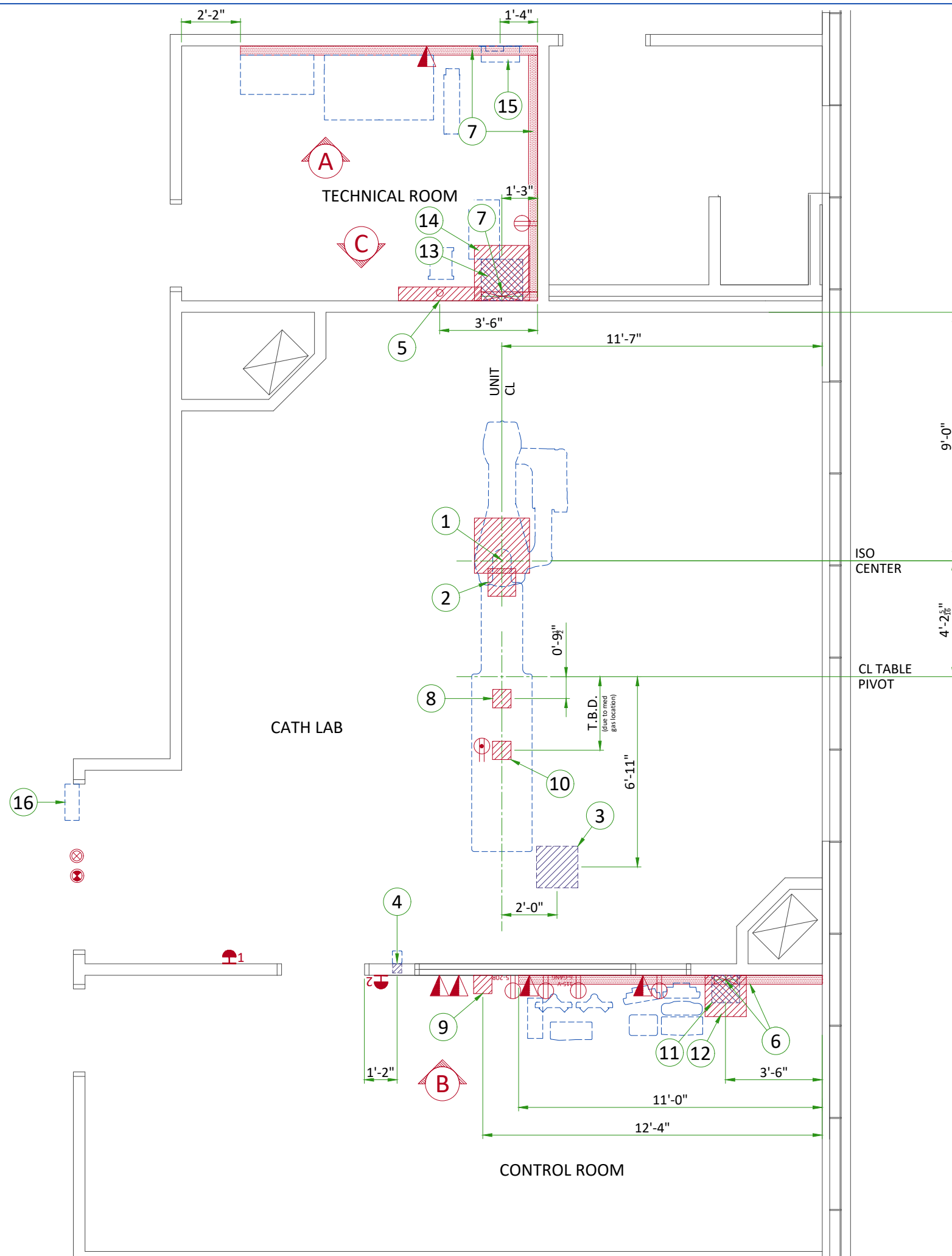

Item	Electrical Layout Item List
1	24" x 24" x 12" [600 x 600 x 300] Box below floor, (1) 6" [150] dia. suitable length threaded pipe, (2) 6" [150] dia. locknuts and (4) 1" [25] dia. locknuts.
2	(1) GE supplied fitting. (1) 12" x 12" x 6" [300 x 300 x 150] Box, (1) 6" [150] dia. bushing, (4) 1" [25] dia. bushing for water lines
3	18"x18"x6" [450 x 450 x 150] flush ceiling box with split coverplate (monitors)
4	4"x4"x4" [100 x 100 x 100] flush wall junction box 12" [300] below finished ceiling (x-ray buzzer)
5	24"x36"x6" [300 x 450 x 150] surface wall box for waterlines and hose storage
6	10" x 3 1/2" [250 x 89] surface wall duct with minimum 2 dividers
7	18" x 3 1/2" [450 x 89] surface wall duct with minimum 2 dividers
8	8" x 8" x 6" [200 x 200 x 150] box below floor (table)
9	8" x 8" x 6" [200 x 200 x 150] box below floor (patient monitoring equipment)
10	8" x 8" x 6" [200 x 200 x 150] box under table (PDM/TRAM)
11	12"x12"x6" [300 x 300 x 150] box above ceiling in control room
12	18" x 18" x 6" [450 x 450 x 150] box below floor in control room
13	18"x18"x6" [450 x 450 x 150] box above ceiling in equipment room
14	24"x24"x12" [600 x 600 x 300] box below floor in equipment room
15	Main disconnect panel (MDP)
16	Light signaling control box

ITEM	QTY	Electrical Outlet Legend
Customer/contractor supplied and installed items unless otherwise specified. Height above floor determined by local codes unless otherwise specified.		
		System emergency off (SEO), (recommended height 1.2m [48"] above floor)
		X-Ray ON lamp (L1) - 24 V
		System ON lamp (L) - 24 V (only if needed per local codes)
		Duplex hospital grade, dedicated wall outlet 120-v, single phase power
		Network outlet
		Duplex hospital grade, dedicated outlet 120-v emergency, single phase power, 15a
		6-Gang hospital grade, dedicated wall outlet 115-V, single phase power
		5-20R NEMA Receptacle, dedicated outlet 120-v, single phase power

Additional Conduit Runs (Contractor Supplied and Installed)					
From (Bubble # / Item)	To (Bubble # / Item)	Qty	Usable length	Size (in)	
1 Gantry	14 CFRT Cabinet	4	64 ft.	4	
1 Gantry	8 Table	1 & 1	19.6 ft.	4&2	
12 Control Room	14 CFRT Cabinet	1 & 2	78.7 ft.	3½&2½	
5 Cooling Line	2 Gantry	1	78.4 ft.	3	
16 Light Signaling Electrical Box	Warning light	1	-	½	
16 Light Signaling Electrical Box	13 System Interface Cabinet	1	-	½	
16 Light Signaling Electrical Box	120-V 1 phase power	1	-	As Req'd	
4 X-Ray Buzzer	13 CFRT Cabinet	1	98.4 ft.	1½	
4 X-Ray Buzzer	11 Control Room	1	98.4 ft.	1½	
3 Monitor Bridge / Boom	11 Control Room	1	88 ft.	2½	
3 Large Display Monitor	13 CFRT Cabinet (LDM server)	1 & 1	92.5 ft.	3&¾	
14 CFRT Cabinet (LDM server)	12 Control Room	1	78.7 ft.	3	
14 CFRT Cabinet (LDM server)	10 TRAM/PDM	1	-	3	
14 System Interface Cabinet	System Emergency Off 1	1	-	½	
	System Emergency Off 2	1	-	½	
14 System Interface Cabinet	System Emergency Off 2	1	-	½	
15 Main Disconnect Panel	# System Interface Cabinet	1	49.5 ft.	1	
15 Main Disconnect Panel	480-V 3 phase power	1	-	As Req'd	
14 Injector Electronics	8 Injector Head	1	-	3	
14 Injector Electronics	12 Injector Control	1	-	3	
9 Patient Monitoring Console	3 Monitor Bridge / Boom	1	-	3	
9 Patient Monitoring Console	10 TRAM/PDM	2	-	3	

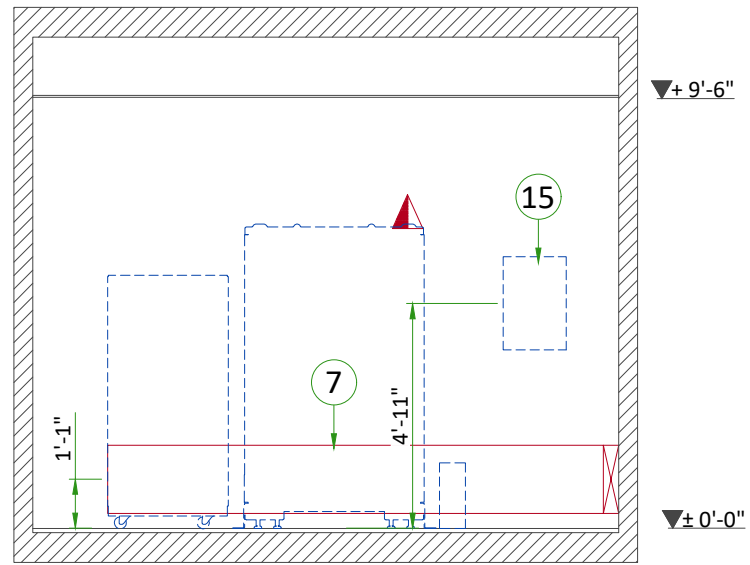

A



B

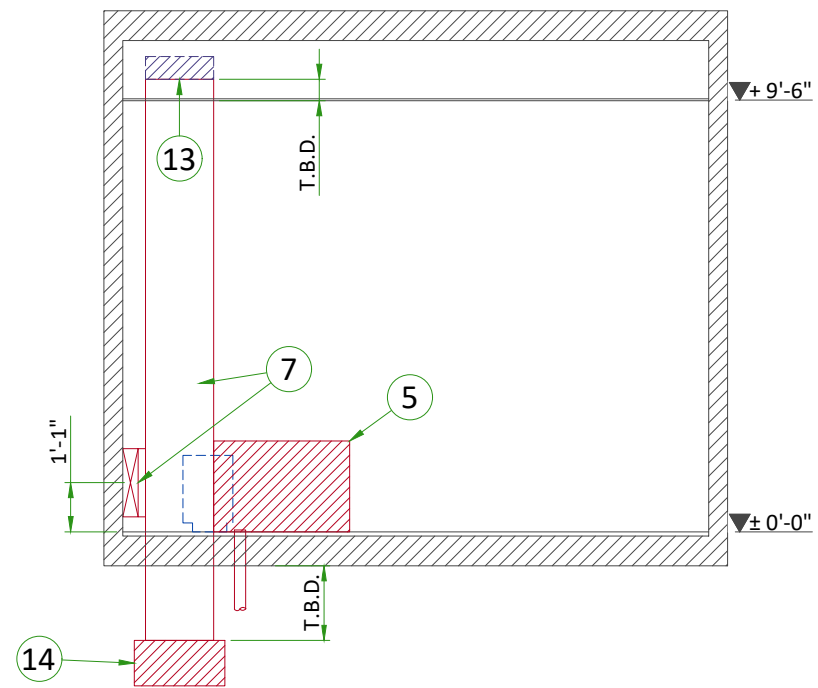

C

POWER REQUIREMENTS

POWER SUPPLY	3 PHASES+G 380/400/415/440/480 V ±10%
FREQUENCIES for 380/400/415V	50/60 Hz ± 3 Hz
FREQUENCY for 440 /480V	60 Hz ± 3Hz
PEAK POWER CONSUMPTION	150 kVA
MOMENTARY POWER CONSUMPTION	100 kVA
LONG TIME POWER CONSUMPTION	15 kVA
STANDBY	3.1 kVA
SYSTEM OFF	0.4 kVA
MINIMUM PROTECTION	100 A (D curve or equivalent)
MAXIMUM LINE IMPEDANCE PER PHASE	380 V : 0.085 Ω / 400 V : 0.085 Ω / 415 V : 0.090 Ω / 440 V : 0.100 Ω / 480 V : 0.120 Ω

- The section of the supply cable should be calculated in accordance with its length and the maximum line impedance per phase and rating of protection minimum 35mm² [2 AWG]
- The Protective Earth cables shall not be smaller than the power cables.
- Hospital shall provide Equipotential busbar in the exam room. Connections shall be so arranged that they are accessible, labeled, clearly visible.
- Governing electrical codes may require a neutral wire. If present, neutral must be terminated in MDP.

SUPPLY CHARACTERISTICS

- Power input must be separated from any others which may generate transients (elevators, air conditioning, radiology rooms equipped with high speed film changers ...)
- All equipment installed with IGS system components must be powered separately (e.g. lighting, power outlets)
- Transients must be less than 2,000 V peak in common mode and 1,000 V in differential mode, with a duration limited to a few microseconds.

CABLES

- MDP to System Interface Cabinet cable shall be copper cable and cable insulation temperature shall be 90°C.
- The cables from signaling and remote control (SEO, L...) will go to System Interface Cabinet with a pigtail length of 2.0 m [6.5 ft] and will be connected during installation.
- Each conductor will be identified and isolated (screw connector).

CABLEWAYS

The general rules for laying cableways should meet the conditions laid down in current standards and regulations, with regard to :

- Protecting cables against water (Cableways should be waterproof),
- Protecting cables against abnormal temperatures (Proximity to heating pipes or ducts),
- Protecting cables against temperature shocks,
- Replacing cables (Cableways should be large enough for cables to be replaced) ,
- Only GE cables are running inside cableways.
- Metal cableways should be grounded.

MANDATORY LOTO REQUIREMENTS

- The MDP shall provide means of disconnecting the mains power from the system, with LOTO capability to ensure safe service operation. It can be done by the input breaker if it has disconnecting capability, or by a separate disconnection device.
- An operator should be able to apply LOTO without opening the MDP box. When a LOTO device is installed on the MDP input breaker or on the disconnecting device, there shall be no voltage at the output of the MDP.

POWER DISTRIBUTION FOR IGS SYSTEM

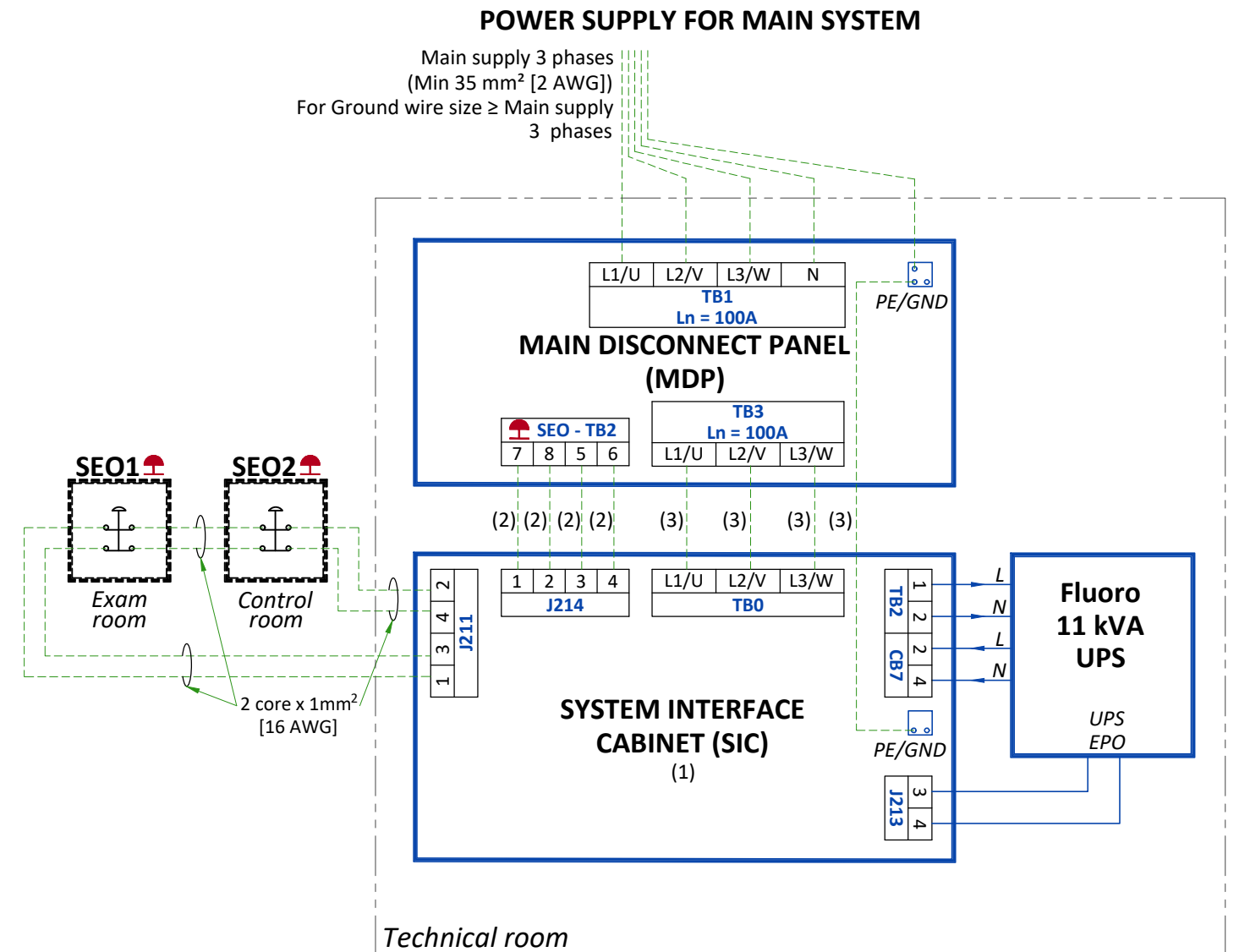

- SEO Emergency OFF button with two normally closed (NC) contacts in the door of MDP
- SEO 1-2 Emergency OFF button with two NC contacts located 1.50 m [5 ft] above floor.
- The EPO buttons shall not be of momentary type.
 - The EPO buttons shall be protected against accidental activation.

NOTES:

- Cable with 2 m [6.6 ft] extra length on the floor behind the SIC
- SEO cable: 4 core x 1mm² [16 AWG]
- Power cable: Min 35 mm² [2 AWG]. For Ground wire size ≥ Main supply 3 phases

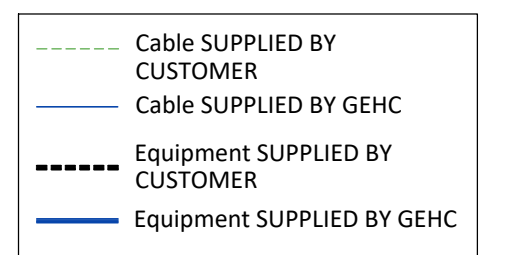

INTERCONNECTIONS

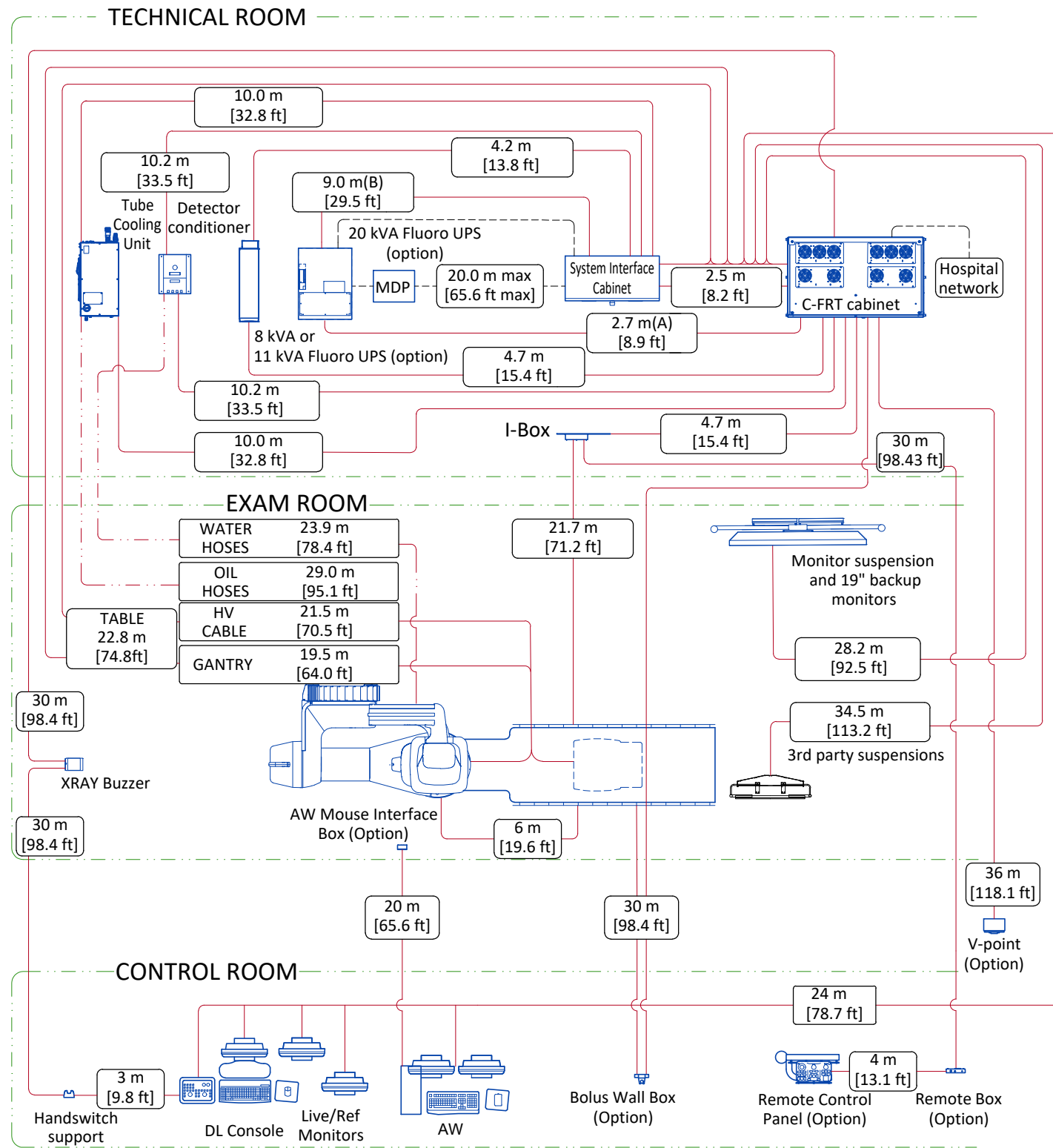

	Cables supplied by the client
	Cables supplied by GEHC
	Liquid lines supplied by GEHC
	Room wall
	Cable length

Notes:
 (A): A 6 m [19.69 ft] Ethernet cable between the C-FRT Cabinet and the Fluoro UPS is provided with the system. If a longer cable is needed, it shall be provided by the hospital; it shall be Cat5 minimum.
 (B): A 12 m [39.37 ft] EPO cable between the System Interface Cabinet and the Fluoro UPS is provided with the system. If a longer cable is needed, it shall be provided by the hospital, its minimum gauge shall be 1 mm² [17 AWG].

POWER REQUIREMENTS (LIGHT SIGNALING)

SPECIFICATIONS OF POWER INPUT

FOR ELECTRICAL BOX LIGHT SIGNALING	
POWER DEMAND	10 A
VOLTAGE	Single Phase 100V - 240V ± 10%
FREQUENCY	50/60 Hz ± 3Hz

POWER DISTRIBUTION (LIGHT SIGNALING)

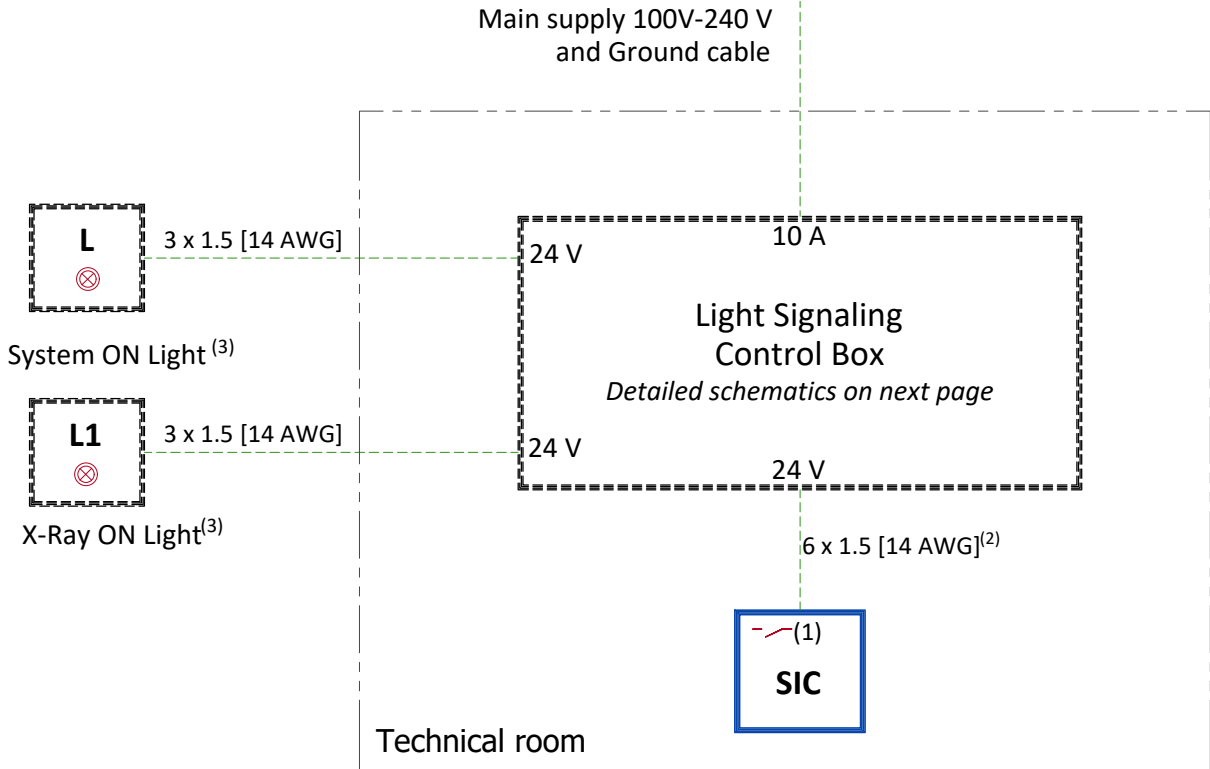

- L System ON light - Located near access doors ⁽³⁾⁽⁴⁾
- L1 XRay ON light - 24 V, Located near access doors and inside the exam room ⁽³⁾⁽⁴⁾
- SIC System Interface Cabinet

NOTES:

(1) Three dry contacts: "System ON", "X-Ray ON" and Room lights control are released by SIC. Max. voltage = 24 V

(2) Cable with 2m [6.6ft] extra length on the floor behind the back of SIC

(3) Location and/or quantity: refer to layout

	Cable SUPPLIED BY CUSTOMER
	Cable SUPPLIED BY GE
	Equipment SUPPLIED BY CUSTOMER
	Equipment SUPPLIED BY GE

DETAILED SCHEMATICS ELECTRICAL BOX (LIGHT SIGNALING)

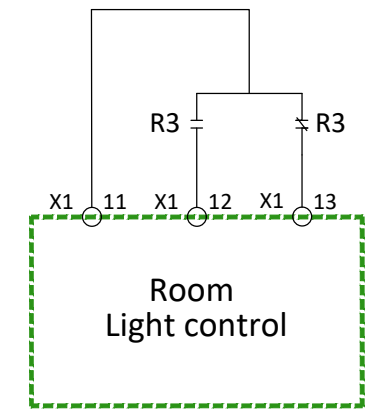
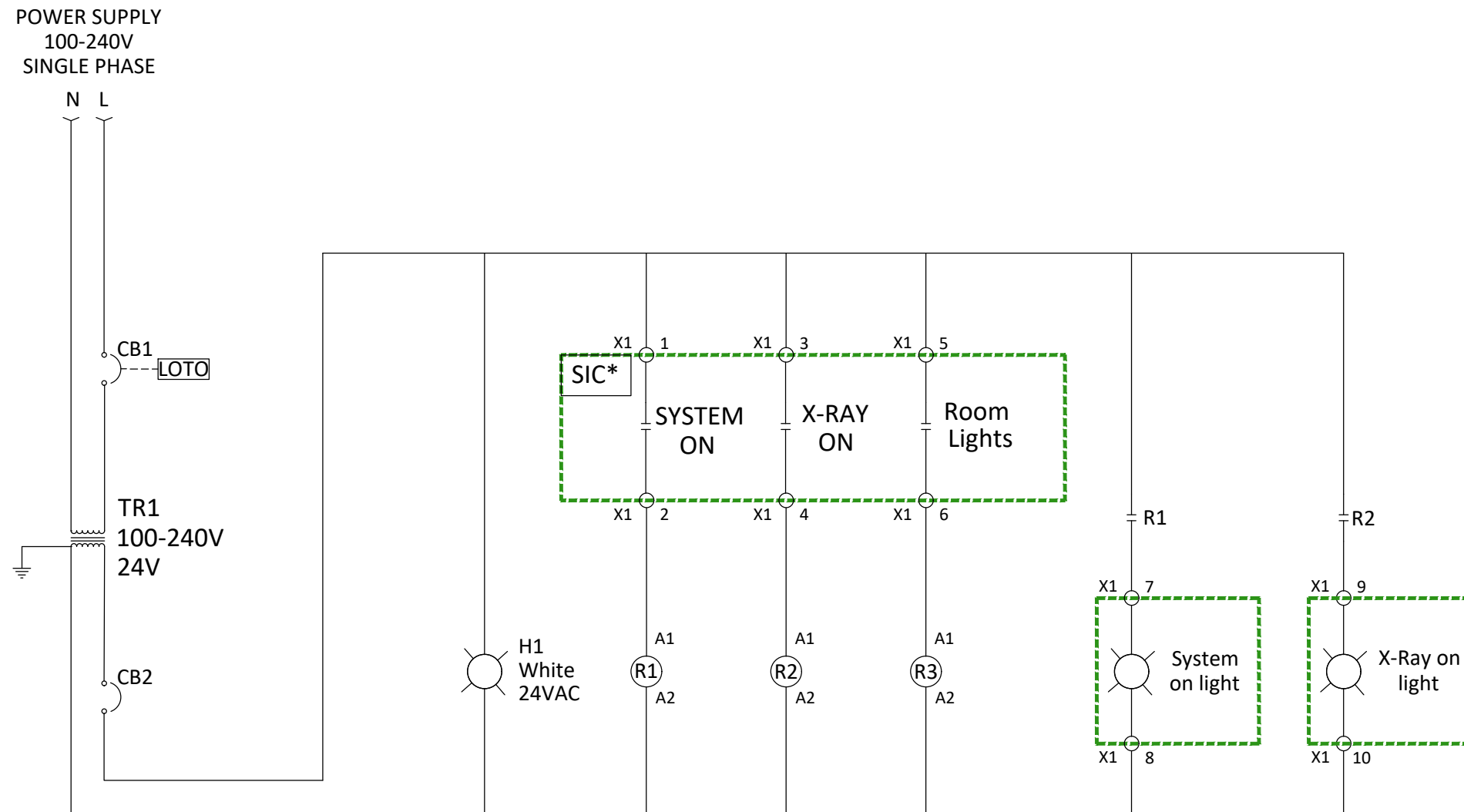

SYMBOLS LEGEND

- Circuit breaker
- Relay coil
- Relay contact - normally open (de-energized state)
- Relay contact - normally closed (de-energized state)
- Control power transformer
- Indication light
- Cable/conductor termination
- External lock-out/tag-out capability
- Ground

CB1/CB2: Circuit breaker
 H1: System ON lamp voltage control
 IG: Lockable interruptor
 L: System ON Lamp

L1: X-Ray ON Lamp
 R1/R2/R3: 24 VAC 50/60 Hz auxiliary relay
 SIC: System Interface Cabinet
 TR1: Transformer
 SIC: System Interface Cabinet

*

TERMINAL X1	SYSTEM ON		X-RAY ON		ROOM LIGHTS	
	1	2	3	4	5	6
SIC ON/OFF BOARD	J155	J106	J110	J110	J110	J110